

Superseded by a more recent version



INTERNATIONAL TELECOMMUNICATION UNION

ITU-T

TELECOMMUNICATION
STANDARDIZATION SECTOR
OF ITU

K.12

(05/95)

PROTECTION AGAINST INTERFERENCE

**CHARACTERISTICS OF GAS DISCHARGE
TUBES FOR THE PROTECTION OF
TELECOMMUNICATIONS INSTALLATIONS**

ITU-T Recommendation K.12

Superseded by a more recent version

(Previously "CCITT Recommendation")

Superseded by a more recent version

FOREWORD

The ITU-T (Telecommunication Standardization Sector) is a permanent organ of the International Telecommunication Union (ITU). The ITU-T is responsible for studying technical, operating and tariff questions and issuing Recommendations on them with a view to standardizing telecommunications on a worldwide basis.

The World Telecommunication Standardization Conference (WTSC), which meets every four years, establishes the topics for study by the ITU-T Study Groups which, in their turn, produce Recommendations on these topics.

The approval of Recommendations by the Members of the ITU-T is covered by the procedure laid down in WTSC Resolution No. 1 (Helsinki, March 1-12, 1993).

ITU-T Recommendation K.12 was revised by ITU-T Study Group 5 (1993-1996) and was approved under the WTSC Resolution No. 1 procedure on the 31st of May 1995.

NOTES

1. In this Recommendation, the expression "Administration" is used for conciseness to indicate both a telecommunication administration and a recognized operating agency.
2. The status of annexes and appendices attached to the Series K Recommendations should be interpreted as follows:
 - an *annexe* to a Recommendation forms an integral part of the Recommendation;
 - an *appendix* to a Recommendation does not form part of the Recommendation and only provides some complementary explanation or information specific to that Recommendation.

© ITU 1995

All rights reserved. No part of this publication may be reproduced or utilized in any form or by any means, electronic or mechanical, including photocopying and microfilm, without permission in writing from the ITU.

Superseded by a more recent version

CONTENTS

	<i>Page</i>
1 Scope	1
2 Definitions	1
3 Environmental conditions	1
4 Electrical characteristics	1
4.1 Spark-over voltages	1
4.2 Holdover voltages	3
4.3 Insulation resistance	3
4.4 Capacitance	3
4.5 Impulse transverse voltage – 3-electrode tubes	4
4.6 Life tests	4
5 Test methods	4
5.1 D.c. spark-over voltage	4
5.2 Impulse spark-over voltage	5
5.3 Insulation resistance	5
5.4 Capacitance	5
5.5 Holdover test	5
5.6 Impulse life – All types of gas discharge tube	6
5.7 Impulse life – Additional tests for tubes designated EXT	6
5.8 A.c. life – All types of tube	6
5.9 Impulse transverse voltage	6
6 Radiation	7
7 Environmental tests	7
7.1 Robustness of terminations	7
7.2 Solderability	7
7.3 Resistance to soldering heat	7
7.4 Vibration	7
7.5 Damp heat cyclic	7
7.6 Sealing	7
7.7 Low temperature	8
8 Identification	8
8.1 Marking	8
8.2 Documentation	8
9 Ordering information	8
Annex A – Test circuit for GDT for ISDN	12
Appendix I – Definitions of terms associated with gas discharge tubes	13

Superseded by a more recent version

INTRODUCTION

This Recommendation gives the basic requirements to be met by gas discharge tubes for the protection of exchange equipment, subscribers' lines and subscribers' equipment from over-voltages. It is intended to be used for the harmonization of existing or future specifications issued by gas discharge tube manufacturers, telecommunication equipment manufacturers, or Administrations.

Only the minimum requirements are specified for essential characteristics. As some users may be exposed to different environments or have different operating conditions, service objectives or economic constraints, these requirements may be modified or further requirements may be added to adapt them to local conditions.

This Recommendation gives guidance on the use of gas discharge tubes to limit over-voltages on telecommunications lines.

Superseded by a more recent version

Recommendation K.12

CHARACTERISTICS OF GAS DISCHARGE TUBES FOR THE PROTECTION OF TELECOMMUNICATIONS INSTALLATIONS

*(Geneva, 1972, modified at Malaga-Torremolinos, 1984
and at Melbourne, 1988; revised in 1995)*

1 Scope

This Recommendation:

- a) gives the characteristics of gas discharge tubes used in accordance with Recommendation K.11 for protection of exchange equipment, subscribers' lines and subscribers' equipment against over-voltages;
- b) deals with gas discharge tubes having 2 or 3 electrodes;
- c) does not deal with mountings and their effect on tube characteristics. Characteristics given apply to gas discharge tubes by themselves mounted only in the ways described for the tests;
- d) does not deal with mechanical dimensions;
- e) does not deal with quality assurance requirements;
- f) does not deal with gas discharge tubes which are connected in series with voltage-dependent resistors in order to limit follow-on currents in electrical power systems;
- g) may not be sufficient for gas discharge tubes used on high frequency or multi-channel systems.

2 Definitions

Appendix I gives definitions of a number of terms used in connection with gas discharge tubes. It includes some terms not used in this Recommendation.

3 Environmental conditions

Gas discharge tubes shall be capable of withstanding during storage the following conditions without damage:

- Temperature: –40 to +90 °C;
- Relative humidity: up to 95%.

See also 7.5 and 7.7.

4 Electrical characteristics

Gas discharge tubes should have the following characteristics when tested in accordance with clause 5.

Subclauses 4.1 to 4.5 apply to new gas discharge tubes and also, where quoted in 4.6, to tubes subjected to life tests.

4.1 Spark-over voltages (see 5.1, 5.2 and Figures 1, 2 and 3)

4.1.1 Spark-over voltages between the electrodes of a 2-electrode tube or between either line electrode and the earth electrode of a 3-electrode tube shall be within the limits in Table 1.

Superseded by a more recent version

TABLE 1/K.12

d.c. spark-over voltage			Maximum impulse spark-over voltage	
Nominal (V)	Minimum (V)	Maximum (V)	at 100 V/μs	at 1000 V/μs
230	180	300	700	900
250/1	200	450	700	900
250/2	200	300	700	900
300	255	345	700	900
350/1	265	600	1000	1100
350/2	290	600	900	1000

4.1.2 For 3-electrode tubes, the spark-over voltage between the line electrodes shall not be less than the minimum d.c. spark-over voltage in Table 1.

4.1.3 The spark-over voltages of gas discharge tubes are random variations. They will conform approximately to a normal distribution provided that a sufficient number of tests are conducted with the time interval between spark-overs specified in 5.1 and 5.2 and appropriate optical isolation between samples. The spark-over voltages should be assessed with the method specified in Table 2.

TABLE 2/K.12

		Measured values before life test		Measured values after life test	
		Probability of the measured values to be within the tolerance	Assessment expression	Probability of the measured values to be within the tolerance	Assessment expression
d.c. sparkover voltage	Grade A	99.7%	$U + 3S \leq \text{Maximum}$ $U - 3S \geq \text{Minimum}$	99.7%	$U + 3S \leq \text{Maximum}$ $U - 3S \geq \text{Minimum}$
	Grade B	95.0%	$U + 1.96S \leq \text{Maximum}$ $U - 1.96S \geq \text{Minimum}$	80.0%	$U + 1.28S \leq \text{Maximum}$ $U - 1.28S \geq \text{Minimum}$
Impulse sparkover voltage	Grade A	99.7%	$U + 3S \leq \text{Maximum}$ $U - 3S \geq \text{Minimum}$ d.c. sparkover voltage	99.7%	$U + 3S \leq \text{Maximum}$ $U - 3S \geq \text{Minimum}$ d.c. sparkover voltage
	Grade B	95.0%	$U + 1.96S \leq \text{Maximum}$ $U - 1.96S \geq \text{Minimum}$ d.c. sparkover voltage	80.0%	$U + 1.28S \leq \text{Maximum}$ $U - 1.28S \geq \text{Minimum}$ d.c. sparkover voltage

NOTE – U is the statistical average value of sparkover voltages.
 S is the standard deviation.
 Grade A: General requirements.
 Grade B: Applicable to gas discharge tubes used for protecting equipment with a higher resistance to overvoltages.

Superseded by a more recent version

4.2 Holdover voltages (see 5.5 and Figures 4 and 5)

All types of tube shall have a current turn-off time less than 150 ms when subjected to one or more of the following tests according to the projected use:

4.2.1 2-electrode tubes tested in a circuit equivalent to Figure 4 where the test circuit components have the values in Table 3. Gas discharge tubes connected to lines with higher d.c. supply voltage, e.g. ISDN, shall be tested according to the test circuit in Annex A.

TABLE 3/K.12

Component	Test 1	Test 2	Test 3
PS1	52 V	80 V	135 V
R3	260 Ω	330 Ω	1300 Ω
R2	(Note)	150 Ω	150 Ω
C1	(Note)	100 nF	100 nF
NOTE – Components omitted in this test.			

4.2.2 3-electrode tubes tested in a circuit equivalent to Figure 5 where components have the values in Table 4.

TABLE 4/K.12

Component	Test 1	Test 2		Test 3	
PS1	52 V	80 V		135 V	
PS2	0 V	0 V		52 V	
R3	260 Ω	330 Ω		1300 Ω	
R2	a)	150 Ω	272 Ω ^{b)}	150 Ω	272 Ω ^{b)}
C1	a)	100 nF	43 nF ^{b)}	100 nF	43 nF ^{b)}
R4 ^{c)}	136 Ω	136 Ω		136 Ω	
C2 ^{c)}	83 nF	83 nF		83 nF	
a) Components omitted in this test. b) Optional alternative. c) Optional.					

4.3 Insulation resistance (see 5.3)

Not less than 1000 Mohms initially.

4.4 Capacitance

Not greater than 20 pF.

Superseded by a more recent version

4.5 Impulse transverse voltage – 3-electrode tubes (see 5.9 and Figure 6)

The difference in time not to exceed 200 ns.

4.6 Life tests (see 5.6, 5.7 and 5.8)

The currents specified in 4.6.1 for the appropriate nominal current rating of the tube shall be applied. After each current application, the gas discharge tube shall be capable of meeting the requirements of 4.6.2. On completion of the number of current applications specified, the tube shall be capable of meeting the requirements of 4.6.3.

4.6.1 Test currents

Gas discharge tubes intended for use only on main distribution frames or similar situations where connection to lines is via cable pairs, shall be subjected to the currents of Columns 2 and 3 of Table 5. Gas discharge tubes intended for applications where they are directly connected to open wire lines will be designated EXT by the purchaser and shall be subjected to the currents of Columns 2, 3 and 4 of Table 5.

TABLE 5/K.12

Nominal current	a.c. 15-62 Hz for 1 s		Impulse current 10/700, 500 applications, or 10/1000, 300 applications	Impulse 8/20, 10 applications (EXT tubes only)
	A rms (2)	No. of applications (3)		
2.5	2.5	5	50	2.5
5	5	5	100	5
10	10	5	100	10
20	20	10	200	20

4.6.2 Requirements during life test

Insulation resistance: not less than 10 Mohms.

D.c. and impulse spark-over voltage: not more than the relevant value in 4.1.

4.6.3 Requirements after completion of life test

Insulation resistance: not less than 100 Mohms (10 Mohms if particularly specified by the purchaser).

D.c. and impulse spark-over voltage: as in 4.1.

Holdover voltage: as in 4.2.

5 Test methods

5.1 D.c. spark-over voltage (see 4.1 and Figures 1 and 2)

The gas discharge tube shall be placed in darkness for at least 24 hours immediately prior to testing and tested in darkness with a voltage which increases so slowly that the spark-over voltage is independent of the rate of rise of the applied voltage. Typically, a rate of rise of 100 V/s is used, but higher rates may be used if it can be shown that the spark-over voltage is not significantly changed thereby. The tolerances on the wave-shape of the rising test voltage are indicated in Figure 1. The voltage is measured across the open-circuited terminals of the generator. U_{max} of Figure 1 is any voltage greater than the maximum permitted d.c. spark-over voltage of the gas discharge tube and less than three times the minimum permitted d.c. spark-over voltage of the gas discharge tube.

Superseded by a more recent version

The test shall employ a suitable circuit such as that shown in Figure 2. A minimum of 15 minutes shall elapse between repetitions of the test, with either polarity, on the same gas discharge tube.

Each pair of terminals of a 3-electrode gas discharge tube shall be tested separately with the other terminal unterminated.

NOTE – The use of Figure 1 may be explained as follows:

A single mask will do for all values of U_{\max} and the nominal rate of rise, provided that it is a suitable size for the display of the waveform and that the scales of U and T of the waveform can be adjusted. This follows because the Y-axis has arbitrary points marked 0 and U_{\max} with $0.2 U_{\max}$ at the appropriate point between them while the X-axis has arbitrary points marked 0 and T_2 with T_1 ($= 0.2 T_2$), $0.9 T_1$, $1.1 T_1$, $0.9 T_2$, $1.1 T_2$ marked at the appropriate points. The X and Y zeros need not coincide and, in fact, need not be shown at all.

To compare a waveform trace with the mask, it is necessary to know the values of U_{\max} and the nominal rate of rise for the waveform in question. As an example, consider a waveform with $U_{\max} = 750$ V and nominal rate of rise = 100 V/sec.

Then $0.2 U_{\max} = 150$ V, $T_2 = 7.5$ s, $T_1 = 1.5$ s.

Hold the mask against the trace and adjust the vertical scale so that the 150 V calibration is against $0.2 U_{\max}$ and the 750 V point against U_{\max} . Adjust the horizontal scale similarly for 1.5 s = T_1 and 7.5 s = T_2 . Slide the mask so that the 150 V point on the trace is within the bottom boundary of the test window; the remainder of the trace up to 750 V must be within the test window.

5.2 Impulse spark-over voltage (see 4.1 and Figures 1 and 3)

The gas discharge tube shall be placed in darkness for at least 15 minutes immediately prior to testing and tested in darkness. The voltage waveform measured across the open circuit test terminals shall have a nominal rate of rise selected from 4.1 and shall be within the enclosed limits indicated in Figure 1. Figure 3 shows a suggested arrangement for testing with a voltage impulse having a nominal rate of rise of 1.0 kV/ μ s.

A minimum of 15 minutes shall elapse between repetitions of the test, with either polarity, on the same gas discharge tube.

Each pair of terminals of a 3-electrode gas discharge tube shall be tested separately with the other terminal unterminated.

5.3 Insulation resistance (see 4.3)

The insulation resistance shall be measured from each terminal to every other terminal of the gas discharge tube. The measurement shall be made at an applied potential of at least 100 V and not more than 90% of the minimum permitted d.c. spark-over voltage. The measuring source shall be limited to a short circuit current of less than 10 mA. Terminals of three-electrode gas discharge tubes not involved in the measurement shall be left unterminated.

5.4 Capacitance (see 4.4)

The capacitance shall be measured between each terminal and every other terminal of the gas discharge tube. In measurements involving 3-electrode gas discharge tubes, the terminal not being tested shall be connected to a ground plane in the measuring instrument.

5.5 Holdover test (see 4.2)

5.5.1 2-electrode gas discharge tube (see Figure 4)

Tests shall be conducted using the circuit of Figure 4. Values of PS1, R2, R3 and C1 shall be selected for each test condition from Table 3. The current from the surge generator shall have an impulse waveform of 100 A, 10/1000 or 10/700 measured through a short circuit replacing the gas discharge tube under test. The polarity of the impulse current through the gas discharge tube shall be the same as the current from PS1. The time for current turn-off shall be measured for each direction of current passage through the gas discharge tube. Three impulses shall be applied at not greater than 1-minute intervals and the current turn-off time measured for each impulse.

Superseded by a more recent version

5.5.2 3-electrode gas discharge tube (see Figure 5)

Tests shall be conducted using the circuit of Figure 5. Values of circuit components shall be selected from Table 4. The simultaneous currents that are applied to the gaps of the gas discharge tube shall have impulse waveforms of 100 A, 10/1000 or 10/700 measured through a short circuit replacing the gas discharge tube under test. The polarity of the impulse current through the gas discharge tube shall be the same as the current from PS1 and PS2.

For each test condition, measurement of the time to current turn-off shall be made for both polarities of the impulse current. Three impulses in each direction shall be applied at intervals not greater than 1 minute and the time to current turn-off measured for each impulse.

5.6 Impulse life – All types of gas discharge tube (see 4.6)

Fresh gas discharge tubes shall be used and impulse currents shall be applied as specified in Table 5, Column 3, for the relevant nominal current of the tube. Half the specified number of tests shall be carried out with one polarity followed by half with the opposite polarity. Alternatively, half the tubes in a sample may be tested with one polarity and the other half with the opposite polarity. The pulse repetition rate should be such as to prevent thermal accumulation in the gas discharge tube.

The voltage of the source shall exceed the maximum impulse spark-over voltage of the gas discharge tube by not less than 50 per cent. The specified impulse discharge current and waveform shall be measured with the gas discharge tube replaced with a short circuit. For 3-electrode gas discharge tubes, independent impulse currents each having the value specified in Table 5, Column 3, shall be discharged simultaneously from each electrode to the common electrode.

The gas discharge tube shall be tested after each passage of impulse discharge current or at less frequent intervals if agreed between the supplier and the purchaser to determine its ability to satisfy the requirements of 4.6.2.

On completion of the specified number of impulse currents, the tube shall be allowed to cool to ambient temperature and tested for compliance with 4.6.3.

5.7 Impulse life – Additional tests for tubes designated EXT (see 4.6)

As in 5.6, but applying the conditions of Table 5, Column 4.

5.8 A.c. life – All types of tube (see 4.6)

Fresh tubes shall be used and alternating currents applied as specified in Table 5, Column 2, for the relevant nominal current of the tube.

The time between applications should be such as to prevent thermal accumulation in the tube. The rms a.c. voltage of the current source shall exceed the maximum d.c. spark-over voltage of the gas discharge tube by not less than 50 per cent.

The specified a.c. discharge current and duration shall be measured with the gas discharge tube replaced with a short circuit. For 3-electrode gas discharge tubes, a.c. discharge currents each having the value specified in Table 5 shall be discharged simultaneously from each electrode to the common electrode.

The gas discharge tube shall be tested after each passage of a.c. discharge current to determine its ability to satisfy the requirements of 4.6.2.

On completion of the specified number of current applications, the tube shall be allowed to cool to ambient temperature and tested for compliance with 4.6.3.

5.9 Impulse transverse voltage (see 4.5 and Figure 6)

The duration of the transverse voltage shall be measured while an impulse voltage having a virtual steepness of impulse wavefront of 1 kV/ μ s is applied simultaneously to both discharge gaps. Measurement may be made with an arrangement as indicated in Figure 6. The difference in time between the spark-over of the first gap and that of the second is specified in 4.5.

Superseded by a more recent version

6 Radiation

The emerging radiation from any radioactive matter used to pre-ionize the discharge gaps must be within the limits specified as admissible in the regulations concerning the protection from radiation which are issued by the country of the manufacturer as well as of the user. This provision applies both to individual and to a batch of gas discharge tubes (for example, when packed in a cardboard box for dispatch, storage, etc.).

The supplier of gas discharge tubes containing radioactive materials shall provide Recommendations, complying with the International Atomic Energy Agency (IAEA) "Regulations for the safe transport of radioactive materials" and with all other relevant international requirements, on the following matters:

- a) maximum number of items per package;
- b) maximum quantity per shipment;
- c) maximum quantity which may be stored together;
- d) any other storage requirements;
- e) handling precautions and requirements;
- f) disposal arrangements.

7 Environmental tests

7.1 Robustness of terminations

The user shall specify a suitable test from International Electrotechnical Commission (IEC) standard 68-2-21 (1975) if applicable.

7.2 Solderability

Soldering terminations shall meet the requirements of IEC standard 68-2-20 (1979) Test Ta Method 1.

7.3 Resistance to soldering heat

Gas discharge tubes with soldering terminations shall be capable of withstanding IEC standard 68-2-20 (1979) Test Tb Method 1B. After recovery, the gas discharge tube shall be visually checked and show no signs of damage and its d.c. spark-over shall be within the limits for that tube.

7.4 Vibration

A gas discharge tube shall be capable of withstanding IEC standard 68-2-6 (1970) 10-500 Hz, 0.15 mm displacement for 90 minutes without damage. The user may select a more severe test from the document. At the end of the test, the tube shall show no signs of damage and shall meet the d.c. spark-over and insulation resistance requirements specified in 4.1 and 4.3.

7.5 Damp heat cyclic

A gas discharge tube shall be capable of withstanding IEC standard 68-2-4 Test D Severity IV. At the end of the test, the tube shall meet the insulation resistance requirement specified in 4.3.

7.6 Sealing

A gas discharge tube shall be capable of passing IEC standard 68-2-17 (1978) Test Qk, severity 600 hours, for fine leaks. Helium shall be used as the test gas. The fine leak rate shall be less than 10^{-7} bar · cm³ · s⁻¹.

The tube shall then be capable of passing the coarse leak test Qc Method 1.

Superseded by a more recent version

7.7 Low temperature

A gas discharge tube shall be capable of withstanding IEC standard 68-2-1 Test Aa. $-40\text{ }^{\circ}\text{C}$, duration 2 hours, without damage. While at $-40\text{ }^{\circ}\text{C}$ the tube must meet the d.c. and impulse spark-over requirements of 4.1.

8 Identification

8.1 Marking

Legible and permanent marking shall be applied to the tube as necessary to ensure that the purchaser can determine the following information by inspection:

- a) manufacturer;
- b) year of manufacture;
- c) type.

The purchaser may specify the codes to be used for this marking.

8.2 Documentation

Documents shall be provided to the purchaser so that from the information in 8.1 he can determine the following further information:

- a) full characteristics as set out in this Recommendation;
- b) name of radioactive material used in the tube or statement that such material has not been used.

9 Ordering information

The following information should be supplied by the purchaser:

- a) drawing giving all dimensions, finishes and termination details (including numbers of electrodes and identifying the earth electrode);
- b) nominal d.c. spark-over voltage, chosen from 4.1.1;
- c) nominal current rating chosen from 4.6.1;
- d) the designation EXT if the tests of Table 5, Column 4, are required;
- e) holdover voltage tests required in 4.2;
- f) marking codes required for 8.1;
- g) robustness of terminations – test required for 7.1;
- h) destruction characteristic, if required, including failure mode (see Note);
- i) quality assurance requirements.

NOTE – After passage of an alternating or impulse current of value much higher than that shown in 4.6.1, the gas discharge tube may be destroyed, i.e. its electrical characteristics may be greatly modified. Two situations may occur:

- 1) The gas discharge tube becomes in effect an insulator and presents a higher dielectric strength than it had initially – that is to say, it becomes open circuit.
- 2) The gas discharge tube becomes of limited resistance – generally a low value which does not allow normal operation of the line – that is to say it becomes a short circuit. (This situation may be preferable from the point of view of protection and maintenance.)

Test methods and the relations between the value and duration of the destructive current are not detailed in this Recommendation nor is the state of the element after destruction. Administrations should cover their requirements in these respects in their own documentation.

Superseded by a more recent version

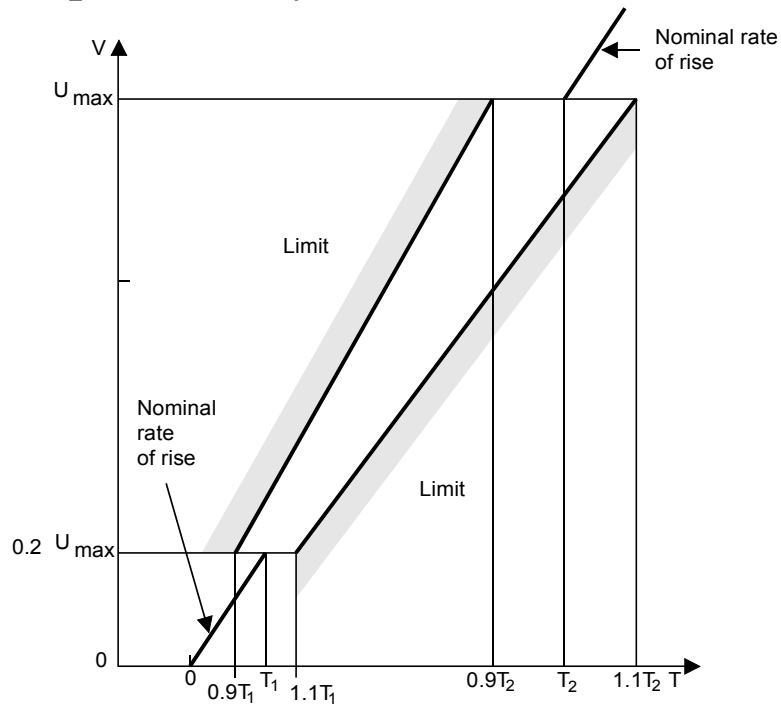

T0506800-95/d01

NOTE – Spark-over test waveform (nonconducting) must be within enclosed limits.

FIGURE 1/K.12

Spark-over test waveform (see 4.1, 5.1 and 5.2)

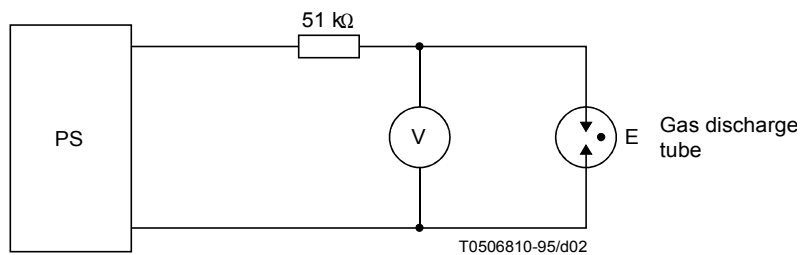

T0506810-95/d02

PS Variable voltage power supply

NOTE – Means shall be included to ensure that the gas discharge tube sparks over once only.

FIGURE 2/K.12

Circuit for d.c. spark-over test (see 4.1 and 5.1)

Superseded by a more recent version

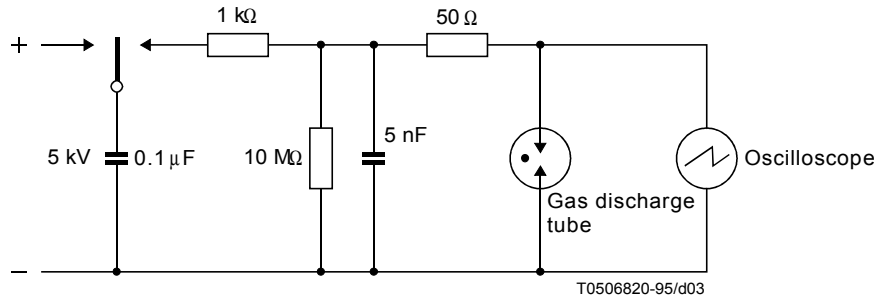
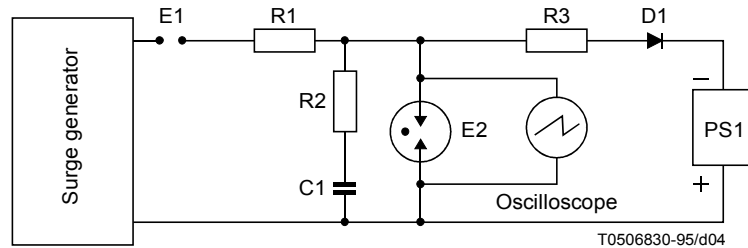

FIGURE 3/K.12

Testing arrangement producing a voltage impulse having a wavefront with a virtual steepness of $1 \text{ kV}/\mu\text{s}$ (see 4.1 and 5.3)



- PS1 Constant voltage d.c. supply or battery
- E1 Isolation gap or equivalent device
- E2 Gas discharge tube
- D1 Isolation diode or other isolation device
- R1 Impulse current limiting resistor or wave-shaping network

FIGURE 4/K.12

Circuit for holdover test of 2-electrode gas discharge tube (see 4.2.1 and 5.5.1)

Superseded by a more recent version

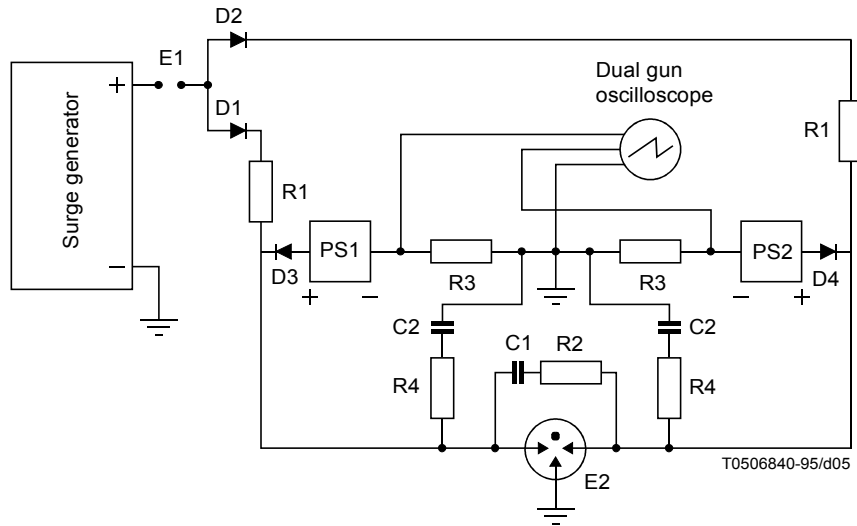

- E1 Isolation gap or equivalent device
- E2 Gas discharge tube
- PS1, PS2 Batteries or d.c. power supplies
- R1 Impulse current limiting resistors or wave-shaping networks

NOTES

- 1 C2 and R4 optional.
- 2 The polarity of diodes D1 to D4 shall be reversed when the polarity of the d.c. power supplies and surge generators are reversed.

FIGURE 5/K.12

**Circuit for holdover test of 3-electrode gas discharge tube
(see 4.2.2 and 5.5.2)**

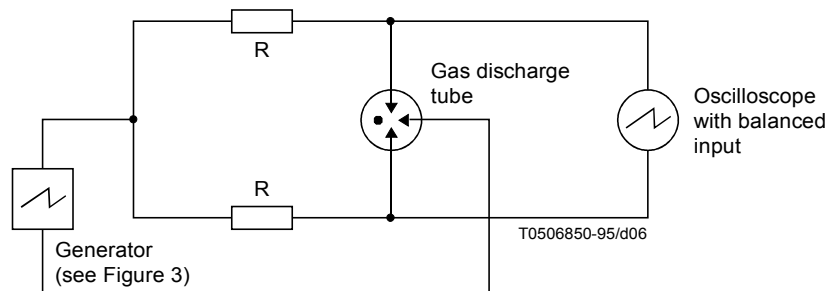

- R Line impedance

FIGURE 6/K.12

**Circuit for impulse transverse voltage test
(see 4.5 and 5.9)**

Superseded by a more recent version

Annex A

Test circuit for GDT for ISDN

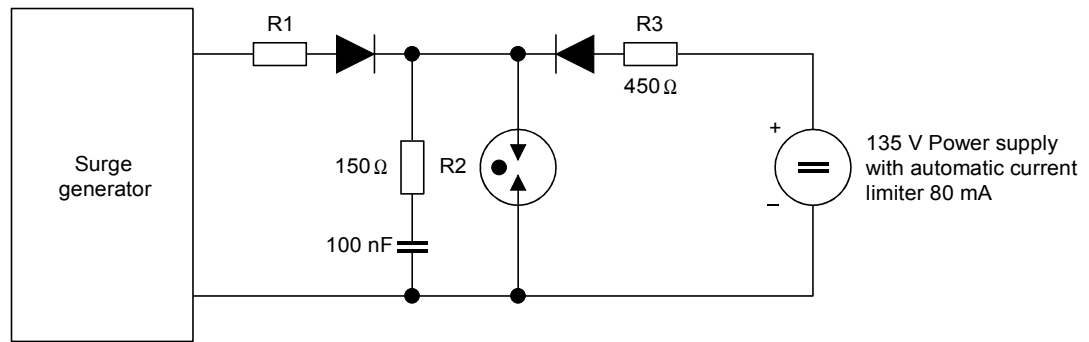
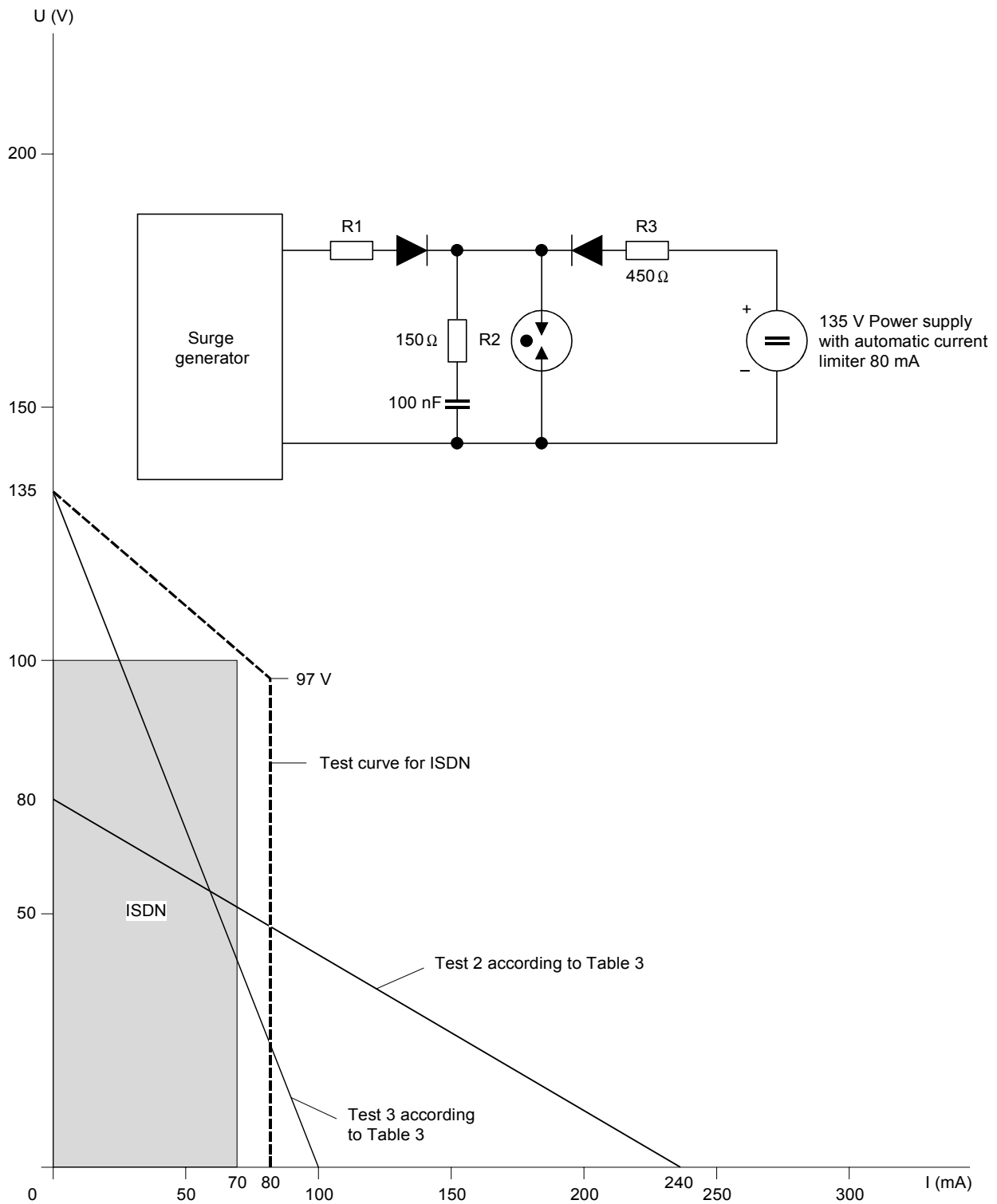

T0506640-94/d07

Superseded by a more recent version

Appendix I

Definitions of terms associated with gas discharge tubes

- I.1 arc current:** The current which flows after spark-over when the circuit impedance allows a current that exceeds the glow-to-arc transition current.
- I.2 arc voltage:** The voltage appearing across the terminals of the gas discharge tube during the passage of the arc current.
- I.3 breakdown:** See “spark-over”.
- I.4 current turn-off time:** The time required for the gas discharge tube to return itself to a nonconducting state following a period of conduction.
- I.5 destruction characteristic:** The relationship between the value of the discharge current and the time of flow until the gas discharge tube is mechanically destroyed (break, electrode short circuit). For periods of time between 1 μ s and some ms, it is based on impulse discharge currents, and for periods of time of 0.1 s and greater, it is based on alternating discharge currents.
- I.6 discharge current:** The current that passes through a gas discharge tube when spark-over occurs.
- I.7 discharge current, alternating:** The r.m.s. value of an approximately sinusoidal alternating current passing through the gas discharge tube.
- I.8 discharge current, impulse:** The peak value of the impulse current passing through the gas discharge tube.
- I.9 discharge voltage:** The voltage that appears across the terminals of a gas discharge tube during the passage of discharge current. Also referred to as “residual voltage”.
- I.10 discharge voltage/current characteristic:** The variation of crest values of discharge voltage with respect to discharge current.
- I.11 follow current:** The current from the connected power source that passes through a gas discharge tube during and following the passage of discharge current.
- I.12 gas discharge tube:** A gap, or several gaps, in an enclosed discharge medium, other than air at atmospheric pressure, designed to protect apparatus or personnel, or both, from high transient voltages. Also referred to as “gas tube surge arrester”.
- I.13 glow current:** The current which flows after spark-over when circuit impedance limits the discharge current to a value less than the glow-to-arc transition current.
- I.14 glow-to-arc transition current:** The current required for the gas discharge tube to pass from the glow mode into the arc mode.
- I.15 glow voltage:** The voltage drop across the terminals of the gas discharge tube during the passage of glow current.
- I.16 holdover voltage:** The maximum d.c. voltage across the terminals of a gas discharge tube under which it may be expected to clear and to return to the high impedance state after the passage of a surge, under specified circuit conditions.
- I.17 impulse spark-over voltage/time curve:** The curve which relates the impulse spark-over voltage to the time to spark over.
- I.18 impulse waveform:** An impulse waveform designated as x/y has a rise time of x μ s and a decay time to half value of y μ s as standardized in IEC Publication 60.
- I.19 nominal alternating discharge current:** For currents with a frequency of 15 Hz to 62 Hz, the alternating discharge current which the gas discharge tube is designed to carry for a defined time.

Superseded by a more recent version

- I.20 nominal d.c. spark-over voltage:** The voltage specified by the manufacturer to designate the gas discharge tube (type designation) and to indicate its application with respect to the service conditions of the installation to be protected. Tolerance limits of the d.c. spark-over voltage are also referred to the nominal d.c. spark-over voltage.
- I.21 nominal impulse discharge current:** The peak value of the impulse current with a defined wave-shape with respect to time for which the gas discharge tube is rated.
- I.22 residual voltage:** See “discharge voltage”.
- I.23 spark-over:** An electrical breakdown of a discharge gap of a gas discharge tube. Also referred to as “breakdown”.
- I.24 spark-over voltage:** The voltage which causes spark-over when applied across the terminals of a gas discharge tube.
- I.25 spark-over voltage, a.c.:** The minimum r.m.s. value of sinusoidal voltage at frequencies between 15 Hz and 62 Hz that results in spark-over.
- I.26 spark-over voltage, d.c.:** The voltage at which the gas discharge tube sparks over with slowly increasing d.c. voltage.
- I.27 spark-over voltage, impulse:** The highest voltage which appears across the terminals of a gas discharge tube in the period between the application of an impulse of given wave-shape and the time when current begins to flow.
- I.28 transverse voltage:** For a gas discharge tube with several gaps, the difference of the discharge voltages of the gaps assigned to the two conductors of a telecommunications circuit during the passage of discharge current.