



INTERNATIONAL TELECOMMUNICATION UNION

ITU-T

TELECOMMUNICATION
STANDARDIZATION SECTOR
OF ITU

K.22

(05/95)

PROTECTION AGAINST INTERFERENCE

**OVERVOLTAGE RESISTIBILITY
OF EQUIPMENT CONNECTED
TO AN ISDN T/S BUS**

ITU-T Recommendation K.22

(Previously "CCITT Recommendation")

FOREWORD

The ITU-T (Telecommunication Standardization Sector) is a permanent organ of the International Telecommunication Union (ITU). The ITU-T is responsible for studying technical, operating and tariff questions and issuing Recommendations on them with a view to standardizing telecommunications on a worldwide basis.

The World Telecommunication Standardization Conference (WTSC), which meets every four years, establishes the topics for study by the ITU-T Study Groups which, in their turn, produce Recommendations on these topics.

The approval of Recommendations by the Members of the ITU-T is covered by the procedure laid down in WTSC Resolution No. 1 (Helsinki, March 1-12, 1993).

ITU-T Recommendation K.22 was revised by ITU-T Study Group 5 (1993-1996) and was approved under the WTSC Resolution No. 1 procedure on the 31st of May 1995.

NOTE

In this Recommendation, the expression "Administration" is used for conciseness to indicate both a telecommunication administration and a recognized operating agency.

© ITU 1995

All rights reserved. No part of this publication may be reproduced or utilized in any form or by any means, electronic or mechanical, including photocopying and microfilm, without permission in writing from the ITU.

CONTENTS

	<i>Page</i>
1 General	1
2 Scope	1
3 Overvoltage and overcurrent conditions	1
4 Equipment boundary	1
5 Test conditions	1
6 Test compliance.....	2
7 Surge tests	2
7.1 Test circuits.....	2
7.2 Tests.....	2
8 Tests for electrostatic discharges.....	2
9 Tests related to mains-powered equipment	3
References	4

OVERVOLTAGE RESISTIBILITY OF EQUIPMENT CONNECTED TO AN ISDN T/S BUS

(Melbourne, 1988; revised in 1995)

1 General

This Recommendation seeks to establish fundamental testing methods and criteria for the resistibility of telecommunication equipment connected to an internal ISDN T/S bus.

Recommendation K.21 should be followed when assessing the resistibility of equipment to be connected directly to a telecommunication network.

2 Scope

This Recommendation relates to any terminal equipment which is intended to be connected to the 4-wire T/S bus of an ISDN installation wholly contained within a building. If cables leave the building, these lines may need to be protected (e.g. additional protective elements or shielded cable). It presumes that suitable isolation is provided between the telecommunication network and the T/S bus at the network termination. It is also assumed that the S-bus has no connection to earth, e.g. no earth-connected voltage-limiting devices with non-linear characteristics can be used. In cases where these assumptions cannot be made, Recommendation K.21 should be followed.

3 Overvoltage and overcurrent conditions

Aspects of overvoltage or overcurrent covered by this Recommendation are:

- surges due to lightning strokes on telecommunication lines or to the building housing the equipment;
- electrostatic discharges generated by users touching the equipment or adjacent plant;
- lightning transient surges on mains-voltage power supplies to the equipment.

4 Equipment boundary

Variations in equipment make it necessary for each unit to be seen as a “black box” having three or more terminals, A, B, etc. Some protective devices may have already been provided within the equipment, e.g. distributed on cards, or connected to internal terminals. For the purposes of these tests, manufacturers are expected to define the boundaries of the “black box” and any protective device which is thereby included must be considered as an immutable part of the equipment.

5 Test conditions

The following general conditions apply:

- 1) All tests are type tests.
- 2) The input terminals at which tests on the equipment are to be applied should be identified by the manufacturer and labelled A, B, etc.
- 3) For the tests specified in clauses 7 and 9 only, the equipment should be enclosed in a foil shroud over those parts likely to have a human contact during use, and the foil connected to the earth terminal (if it is provided).
- 4) The equipment should be tested in each operating mode of significant duration.

- 5) The equipment should pass tests under clauses 7 and 9 through the ranges of temperature and humidity of its intended use.
- 6) In all cases where a maximum voltage is specified, tests shall also be made at lower voltages if it is necessary to confirm that the equipment will resist any voltage up to the maximum specified.

6 Test compliance

Equipment shall withstand all tests without damage or other disturbance, e.g. corruption of software, misoperation of fault-protection facilities, and shall operate properly within specified limits after the tests. It is not required to operate correctly while the test condition is present.

If specifically permitted by the Administration, the tests may cause the operation of fuses or other devices which have to be replaced or reset before normal operation is restored.

7 Surge tests

7.1 Test circuits

Three alternative test circuits may be used:

- a surge generator of 1.2/50 μs open-circuit voltage waveshape and 8/20 μs short-circuit current waveshape;
- a surge generator of 2/10 μs open-circuit voltage waveshape and the same short-circuit current waveshape;
- a surge generator of 1.2/50 μs open-circuit voltage waveshape and a corresponding short-circuit current waveshape. Figure 1 illustrates a typical test circuit.

The short-circuit current provided by the surge generator shall be approximately 100 A.

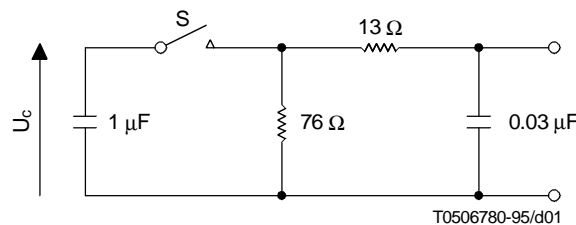

FIGURE 1/K.22

Typical surge generator circuit (see 7.1)

7.2 Tests

The open-circuit voltage of the surge generator should be 1 kV. The surge generator should be connected to the equipment under test through the circuit of Figure 2. Ten tests should be made with alternating positive and negative polarities.

8 Tests for electrostatic discharges

The equipment should meet the requirements of IEC publication 801-2 [1] when tested to both severity levels 2 and 4. The two severity levels have been chosen to ensure the equipment is tested with both fast rise times and high test voltages.

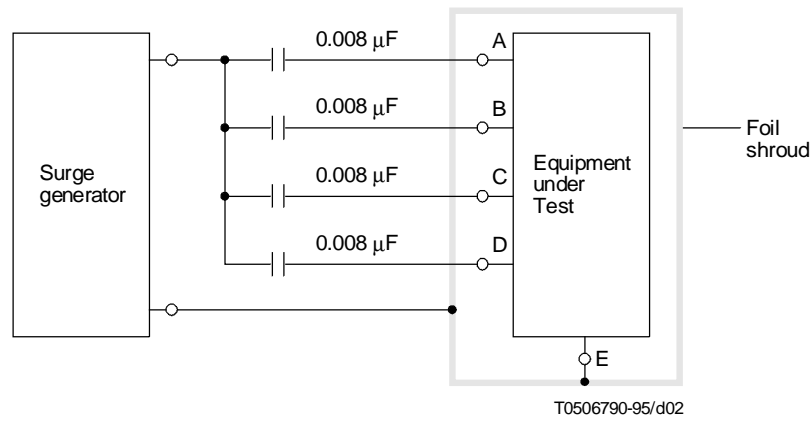

FIGURE 2/K.22

Connection of surge generator to equipment under test (see 7.2)

9 Tests related to mains-powered equipment

The following tests are made on mains-powered equipment to ensure that the equipment can adequately resist high voltage surges which may arise on power conductors from lightning or other causes, such as load switching.

The equipment under test should be tested with normal operating power applied and with the telecommunication line access at the equipment terminated in such a manner as to simulate the conditions in each state of operation of significant duration.

Equipment not complying with a) below should meet the requirements of clause 6 when tested with surge tests applied between phase, neutral and protective earth terminals of the equipment in accordance with b) below.

a) *Insulation coordination*

IEC publication 664 [2] describes overvoltage categories for mains-powered equipment, including telecommunication equipment, in respect of overvoltages arising in the supply network. Most subscribers' equipment is expected to be installed in overvoltage category 11 in which the maximum surge voltage arriving at its mains terminals is 2.5 kV peak. Given this and certain other assumptions about atmospheric pollution (e.g. dust) and the quality of insulation, IEC 664 gives guidance to IEC standards committees on coordinated creepage distances and clearances that can be expected to give adequate performance during the lifetime of the equipment.

The guidance in IEC 664 has been adopted in IEC publication 950 [3]. Subject to cases mentioned in c) below, telecommunication equipment that employs insulation spacings that are dimensioned and tested in accordance with IEC 950 need not be subjected to further tests under this Recommendation.

b) *No insulation coordination*

Where reliance is not placed on insulation coordination, the equipment shall be subjected to tests along the lines indicated in [3] to [5].

c) *Exceptional voltages*

In cases where electrical disturbances may be of exceptional amplitude or simply greater than the values adopted for the tests, it is recommended that additional protective measures external to the terminal equipment be used, e.g.:

- power transformers with a high dielectric strength (of the order of 10 kV) in relation to the mains leads;
- overvoltage limiting devices such as lightning arrestors, air gaps, non-linear resistances, etc.;
- combinations of the above.

NOTES

1 For situation a), the experience of one country has shown that a K.17 generator may be substituted, i.e. with a waveshape 10/700 μ s and an internal impedance of 40 ohms. A test voltage of $V_{c(max)} = 2.5$ kV assured a satisfactory performance of equipment operated at a load level interface of low-voltage distribution systems with a nominal voltage of 230/400 V.

2 Attention is drawn to matters of safety which relate to electrical barriers between the mains power and telecommunication line terminals. These are normally subject to national regulations which have to be followed in each country.

3 The attention of the reader is drawn to the following subjects which CCITT is studying further:

- rise of earth potential;
- electrical fast transients;
- operational tests for barriers between mains ports and telecommunication ports;
- high frequency mains-voltage surges;
- short duration interruptions of mains voltages.

When these studies have been completed, this Recommendation may be expanded.

References

- [1] IEC publication 801-2, *Electromagnetic compatibility for industrial-process measurement and control equipment – Part 2: Electric discharge requirements*, Geneva 1984.
- [2] IEC publication 664, *Insulation coordination within low-voltage systems including clearances and creepage distances for equipment*, Geneva 1980.
- [3] IEC publication 950, *Safety of information technology equipment including electrical business equipment*, Geneva 1986.
- [4] ANSI/IEEE Standard C 62.41, *IEEE guide for surge voltages in low-voltage AC power circuits*, New York, 1980.
- [5] CENELEC ENV 41003, *Particular requirements for information technology equipment when connected to a telecommunications network*, Brussels 1988.