

I n t e r n a t i o n a l   T e l e c o m m u n i c a t i o n   U n i o n

**ITU-T**

TELECOMMUNICATION  
STANDARDIZATION SECTOR  
OF ITU

**K.61**

(02/2008)

SERIES K: PROTECTION AGAINST INTERFERENCE

---

**Guidance on measurement and numerical  
prediction of electromagnetic fields for  
compliance with human exposure limits for  
telecommunication installations**

Recommendation ITU-T K.61





## **Recommendation ITU-T K.61**

### **Guidance on measurement and numerical prediction of electromagnetic fields for compliance with human exposure limits for telecommunication installations**

#### **Summary**

Recommendation ITU-T K.61 helps telecommunication operators to verify compliance with exposure standards promulgated by local or national authorities. This Recommendation gives guidance on measurement methods that can be used to achieve a compliance assessment. It also provides guidance on the selection of numerical methods suitable for exposure prediction in various situations.

#### **Source**

Recommendation ITU-T K.61 was approved on 29 February 2008 by ITU-T Study Group 5 (2005-2008) under Recommendation ITU-T A.8 procedure.

#### **Keywords**

RF exposure, RF safety.

## FOREWORD

The International Telecommunication Union (ITU) is the United Nations specialized agency in the field of telecommunications, information and communication technologies (ICTs). The ITU Telecommunication Standardization Sector (ITU-T) is a permanent organ of ITU. ITU-T is responsible for studying technical, operating and tariff questions and issuing Recommendations on them with a view to standardizing telecommunications on a worldwide basis.

The World Telecommunication Standardization Assembly (WTSA), which meets every four years, establishes the topics for study by the ITU-T study groups which, in turn, produce Recommendations on these topics.

The approval of ITU-T Recommendations is covered by the procedure laid down in WTSA Resolution 1.

In some areas of information technology which fall within ITU-T's purview, the necessary standards are prepared on a collaborative basis with ISO and IEC.

## NOTE

In this Recommendation, the expression "Administration" is used for conciseness to indicate both a telecommunication administration and a recognized operating agency.

Compliance with this Recommendation is voluntary. However, the Recommendation may contain certain mandatory provisions (to ensure e.g. interoperability or applicability) and compliance with the Recommendation is achieved when all of these mandatory provisions are met. The words "shall" or some other obligatory language such as "must" and the negative equivalents are used to express requirements. The use of such words does not suggest that compliance with the Recommendation is required of any party.

## INTELLECTUAL PROPERTY RIGHTS

ITU draws attention to the possibility that the practice or implementation of this Recommendation may involve the use of a claimed Intellectual Property Right. ITU takes no position concerning the evidence, validity or applicability of claimed Intellectual Property Rights, whether asserted by ITU members or others outside of the Recommendation development process.

As of the date of approval of this Recommendation, ITU had not received notice of intellectual property, protected by patents, which may be required to implement this Recommendation. However, implementers are cautioned that this may not represent the latest information and are therefore strongly urged to consult the TSB patent database at <http://www.itu.int/ITU-T/ipr/>.

© ITU 2008

All rights reserved. No part of this publication may be reproduced, by any means whatsoever, without the prior written permission of ITU.

## CONTENTS

	<b>Page</b>
1	Scope ..... 1
2	References..... 1
3	Terms and definitions ..... 2
4	Abbreviations and acronyms ..... 3
5	General principles..... 4
5.1	Quantities being measured ..... 4
5.2	Typical situations..... 4
6	Technical considerations ..... 5
6.1	Averaging ..... 5
6.2	Quantities..... 5
6.3	Field regions ..... 5
6.4	Shadowing and scattering..... 7
6.5	Variability of the source ..... 7
7	Measurements ..... 8
7.1	Measurement instrumentation ..... 8
7.2	Evaluation of measurement uncertainties..... 11
7.3	Probe selection..... 11
7.4	Procedures ..... 12
7.5	Safety precautions ..... 12
7.6	Field region..... 12
7.7	Multiple sources ..... 12
7.8	Time and spatial variability ..... 12
8	Compliance with the limit: measurement results processing ..... 13
8.1	Identification of individual sources ..... 13
8.2	Intermittent sources ..... 14
8.3	Base stations for radio-mobile systems ..... 14
Appendix I – Calculation methods..... 16	
I.1	General ..... 16
I.2	Methods description ..... 16
I.3	Other near-field models..... 17
I.4	Practical problems ..... 18
Appendix II – Identification and measurement of the main source of radiation ..... 19	
II.1	Treatment of non-conformities – Exceeding the exposure limits ..... 19
II.2	Confirmation measurement ..... 19
Bibliography..... 20	

## **Introduction**

This Recommendation helps telecommunication operators to verify compliance with exposure standards promulgated by local or national authorities. Recommendation ITU-T K.52 provides indications on the need to perform an exposure assessment for a telecommunication installation. The assessment is based on the evaluation of the electromagnetic field and on accessibility considerations. The electromagnetic evaluation can be carried out by measurement or numerical prediction.

This Recommendation defines tools, methods and procedures that can be used to achieve a compliance assessment. The compliance with radio-frequency exposure standards can be achieved by measurement of electromagnetic field strength, provided that calibrated instruments are used and measurement uncertainty is correctly expressed.

# Recommendation ITU-T K.61

## Guidance on measurement and numerical prediction of electromagnetic fields for compliance with human exposure limits for telecommunication installations

### 1 Scope

This Recommendation deals with measurements used for radio-frequency electromagnetic field strength evaluation to verify that human exposure limits are not exceeded by electromagnetic fields produced by telecommunication installations in the frequency range 9 kHz to 300 GHz. Also, this Recommendation gives guidance on computational methods that can be used to achieve a compliance assessment.

Contact current exposure due to conductive objects irradiated by electromagnetic field is not covered in this Recommendation.

The exposure due to the use of mobile handsets or other radiating devices used in close proximity to the human body is not covered. Also, the exposure due to the use of cordless telephone systems and stationary sets intended for the use in wireless telecommunication networks (e.g., DECT, WLAN, Bluetooth, etc.) is not covered.

### 2 References

The following ITU-T Recommendations and other references contain provisions which, through reference in this text, constitute provisions of this Recommendation. At the time of publication, the editions indicated were valid. All Recommendations and other references are subject to revision; users of this Recommendation are therefore encouraged to investigate the possibility of applying the most recent edition of the Recommendations and other references listed below. A list of the currently valid ITU-T Recommendations is regularly published. The reference to a document within this Recommendation does not give it, as a stand-alone document, the status of a Recommendation.

- [ITU-T K.52] Recommendation ITU-T K.52 (2000), *Guidance on complying with limits for human exposure to electromagnetic fields.*
- [ITU-T K.70] Recommendation ITU-T K.70 (2007), *Mitigation techniques to limit human exposure to EMFs in the vicinity of radiocommunication stations.*
- [ITU-R BS.1698] Recommendation ITU-R BS.1698 (2005), *Evaluating fields from terrestrial broadcasting transmitting systems operating in any frequency band for assessing exposure to non-ionizing radiation.*
- [EN 50383] CENELEC EN 50383:2002, *Basic standard for the calculation and measurement of electromagnetic field strength and SAR related to human exposure from radio base stations and fixed terminal stations for wireless telecommunication systems (110 MHz-40 GHz).*  
<[http://tcelis.cenelec.be/pls/portal30/CELISPROC.RPT\\_WEB\\_PROJECT\\_D.SHOW?p\\_arg\\_names=project\\_number&p\\_arg\\_values=21117](http://tcelis.cenelec.be/pls/portal30/CELISPROC.RPT_WEB_PROJECT_D.SHOW?p_arg_names=project_number&p_arg_values=21117)>
- [EN 50400] CENELEC EN 50400:2006, *Basic standard to demonstrate the compliance of fixed equipment for radio transmission (110 MHz-40 GHz) intended for use in wireless telecommunication networks with the basic restrictions or the reference levels related to general public exposure to radio frequency electromagnetic fields, when put into service.*  
<[http://tcelis.cenelec.be/pls/portal30/CELISPROC.RPT\\_WEB\\_PROJECT\\_D.SHOW?p\\_arg\\_names=project\\_number&p\\_arg\\_values=21906](http://tcelis.cenelec.be/pls/portal30/CELISPROC.RPT_WEB_PROJECT_D.SHOW?p_arg_names=project_number&p_arg_values=21906)>

- [IEC 60657] IEC 60657 (1979), *Non-ionizing radiation hazards in the frequency range from 10 MHz to 300 000 MHz.*  
<<http://webstore.iec.ch/webstore/webstore.nsf/artnum/016856>>
- [IEC 61566] IEC 61566 (1997), *Measurement of exposure to radio-frequency electromagnetic fields – Field strength in the frequency range 100 kHz to 1 GHz.*  
<<http://webstore.iec.ch/webstore/webstore.nsf/artnum/022234>>
- [IEC 62311] IEC 62311 (2007), *Assessment of electronic and electrical equipment related to human exposure restrictions for electromagnetic fields (0 Hz - 300 GHz).*  
<<http://webstore.iec.ch/webstore/webstore.nsf/artnum/038218>>
- [ISO/IEC GUM] ISO/IEC Guide 98:1995, *Guide to the expression of uncertainty in measurement (GUM).*  
<[http://www.iso.org/iso/iso\\_catalogue/catalogue\\_tc/catalogue\\_detail.htm?csnumber=45315](http://www.iso.org/iso/iso_catalogue/catalogue_tc/catalogue_detail.htm?csnumber=45315)>

### 3 Terms and definitions

This Recommendation defines the following terms:

**3.1 far-field region:** That region of the field of an antenna where the angular field distribution is essentially independent of the distance from the antenna. In the far-field region, the field has predominantly plane-wave character, i.e., locally uniform distribution of electric field strength and magnetic field strength in planes transverse to the direction of propagation.

**3.2 near-field region:** The near-field region exists in proximity to an antenna or other radiating structure in which the electric and magnetic fields do not have a substantially plane-wave character but vary considerably from point to point. The near-field region is further subdivided into the reactive near-field region, which is closest to the radiating structure and that contains most or nearly all of the stored energy, and the radiating near-field region where the radiation field predominates over the reactive field, but lacks substantial plane-wave character and is complicated in structure.

NOTE – For many antennas, the outer boundary of the reactive near field is taken to exist at a distance of one wavelength from the antenna surface.

**3.3 radio frequency (RF):** Any frequency at which electromagnetic radiation is useful for telecommunication.

NOTE – In this Recommendation, radio frequency refers to the frequency range 9 kHz-300 GHz allocated by ITU-R Radio Regulations.

**3.4 specific absorption (SA):** Specific absorption is the quotient of the incremental energy ( $dW$ ) absorbed by (dissipated in) an incremental mass ( $dm$ ) contained in a volume element ( $dV$ ) of a given density ( $\rho_m$ ).

$$SA = \frac{dW}{dm} = \frac{1}{\rho_m} \frac{dW}{dV}$$

The specific absorption is expressed in units of joules per kilogram (J/kg).

**3.5 specific absorption rate (SAR):** The time derivative of the incremental energy ( $dW$ ) absorbed by (dissipated in) an incremental mass ( $dm$ ) contained in a volume element ( $dV$ ) of a given mass density ( $\rho_m$ ).

$$SAR = \frac{d}{dt} \frac{dW}{dm} = \frac{d}{dr} \left( \frac{1}{\rho_m} \frac{dW}{dV} \right)$$

SAR is expressed in units of watts per kilogram (W/kg).



SAR can be calculated by:

$$SAR = \frac{\sigma E^2}{\rho_m}$$

$$SAR = c \frac{dT}{dt}$$

$$SAR = \frac{J^2}{\rho_m \sigma}$$

where:

$E$  is the value of the electric field strength in body tissue in V/m

$\sigma$  is the conductivity of body tissue in S/m

$\rho_m$  is the density of body tissue in kg/m<sup>3</sup>

$c$  is the heat capacity of body tissue in J/kg°C

$\frac{dT}{dt}$  is the time derivative of temperature in body tissue in °C/s

$J$  is the value of the induced current density in the body tissue in A/m<sup>2</sup>

**3.6 wavelength ( $\lambda$ ):** The wavelength of an electromagnetic wave is related to frequency ( $f$ ) and velocity ( $v$ ) of an electromagnetic wave by the following expression:

$$\lambda = \frac{v}{f}$$

In free space, the velocity is equal to the speed of light ( $c$ ) which is approximately  $3 \times 10^8$  m/s.

#### 4 Abbreviations and acronyms

This Recommendation uses the following abbreviations and acronyms:

AF	Antenna Factor
APC	Automatic Power Control
BCCH	Base Station Control Channel
CF	Calibration Factor
DTX	Discontinuous Transmission
EIRP	Equivalent Isotropically Radiated Power
EM	Electromagnetic
EMC	Electromagnetic Compatibility
EMF	Electromagnetic Field
ICNIRP	International Commission on Non-Ionizing Radiation Protection
PC	Personal Computer
RF	Radio Frequency
RMS	Root Mean Square
SA	Specific Absorption
SAR	Specific Absorption Rate

## 5 General principles

[ITU-T K.52] provides a procedure for achieving a compliance with EMF safety limits. The steps needed to achieve compliance are:

- 1) Identify appropriate compliance limits.
- 2) Determine if EMF exposure assessment for the installation of equipment in question is needed.
- 3) If the EMF exposure assessment is needed, it may be performed by calculations or measurement.
- 4) If the EMF exposure assessment indicates that pertinent exposure limits may be exceeded in areas where people may be present, mitigation/avoidance measures should be applied.

This Recommendation provides guidance on measurements and calculations of the EMF fields (step 3). Additional information on exposure assessment can be found in [ITU-T K.70], [ITU-R BS.1698], [IEC 62311], [EN 50383], [EN 50400], [b-IEC 62232], [b-FprEN 50492], [b-FprEN 50413] and [b-IEEE P.1597.1]. It is also recommended to ensure that exposure assessment is conducted in accordance with the applicable national or regional standards and regulations.

NOTE – These more sophisticated methods to assess field exposure are needed to refine the zone boundaries obtained using [ITU-T K.52] or for complex situations where the methods of [ITU-T K.52] may be insufficient. For example, it may be useful to refine the results of [ITU-T K.52] where they indicate an appearance of exceedance zone or occupational zone marginally. A measurement or more accurate calculation can help determine whether the zone determination is correct or is an artefact of the conservative estimation methods of [ITU-T K.52]. Another example where measurements may be needed is for complex scattering environments or for environments with a number of significant sources of EM radiation.

### 5.1 Quantities being measured

Most documents provide safety limits in terms of basic restrictions and reference (or derived) levels. The basic restrictions address the fundamental quantities that determine the physiological response of the human body to EMFs. Basic restrictions apply to a situation with the body present in the field. The basic restrictions for human exposure are expressed as the *SAR*, *SA* and current density. *SAR* assessment is not in the scope of this Recommendation. More information can be found in [IEC 62311], [EN 50383], [b-IEC 62232], [b-FprEN 50492], [b-FprEN 50413] and [b-IEEE P.1597.1].

As the basic restrictions are difficult to measure directly, most documents provide derived reference levels for electric field, magnetic field and power density. The reference levels apply to a situation where the assessment of electromagnetic field is not influenced by the presence of a body. The normative part of the Recommendation provides guidelines for measurement of reference levels.

Reference levels may be exceeded if the exposure condition can be shown to produce *SAR*, *SA* and induced current density below the basic limits. Therefore, Appendix I provides guidance on selecting computational procedures that can be used to calculate the *SAR*.

### 5.2 Typical situations

The measurement problem typically approaches one of the following cases:

- 1) The source of the EMF and at least some of its characteristics are known. The EMF from other sources is negligible for compliance considerations. The objective is to determine the compliance zones for this known source.

- 2) The sources of the EMF are not known. The objective is to determine compliance in a particular location, or to survey the EM fields in the out-band region to confirm that other EM sources can be neglected.
- 3) The objective is to determine compliance in a particular location, and if non-compliance is found, to determine the relative contribution of the sources to the non-compliance.

In case 1, the emission frequency band should be known precisely. The transmitted power, polarization and the antenna pattern may be known approximately. Thus, the measurements can focus onto the frequency range of interest. [ITU-T K.52] should be used to obtain an estimate of the field strength in order to determine appropriate instrumentation.

In case 2, a survey of the entire frequency spectrum may be required. An alternative is measurement with a wideband probe that integrates various frequencies. Case 3 is an extension of case 2. If the initial measurement indicates non-compliance, frequency-selective measurements, an antenna and spectrum analyser, for example, are needed.

## **6 Technical considerations**

### **6.1 Averaging**

#### **6.1.1 Time averaging**

Limits are usually expressed as RMS values of a continuous wave averaged over a defined period. For example, ICNIRP reference (i.e., field) limits are to be averaged over any 6-minute period below 10 GHz and over a  $68/f^{1.05}$ -minute period for frequencies exceeding 10 GHz (where  $f$  is the frequency in GHz). Therefore, for strongly time-dependant signals, an elaboration of measurement results (post-processing procedure) may be necessary to be compared with the limit.

#### **6.1.2 Spatial averaging**

SAR limits typically comprise two categories: localized SAR limits and whole-body average SAR limits. The localized SAR limits are pertinent to localized exposures due to small radiators close to the body such as mobile phones. The whole-body average SAR limits are the basis for the reference levels. The reference levels are generally intended to be spatially averaged values over the dimension of the body of the exposed individual, but with the important proviso that the localized basic restrictions on exposure are not exceeded.

For telecommunication installations, the highest field values occur close to the antennas in regions where the fields may vary appreciably on the scale of the size of the human body. In these cases, spatial averaging can be used for a more accurate result.

### **6.2 Quantities**

Exposure standards usually refer to electric and magnetic component or power density limits. They are individually measured only when it is required by the field properties related to the field regions.

### **6.3 Field regions**

The properties of EMFs need to be taken into consideration for their measurement and evaluation. For example:

- measurement of both the electric and magnetic components may be necessary in the non-radiating near-field region;
- for numerical prediction: the far-field model usually leads to an overestimation of the field if applied in near-field regions.

Therefore, it is important to be aware of the boundaries of each field region before starting a compliance procedure.

### 6.3.1 Reactive near-field zone

It is the portion of the near-field region that is immediately surrounding the antenna and where the reactive field predominates. This region is commonly assumed to extend to a distance of one wavelength from the antenna.

### 6.3.2 Reactive-radiative near-field region

At the boundary to the reactive near-field zone, a transition region may be defined wherein the radiating field is beginning to be important compared with the reactive component. This outer region extends to a few (e.g.,  $3\lambda$ ) wavelengths from the electromagnetic source.

### 6.3.3 Radiating near-field (Fresnel) zone

The region of the field of an antenna between the reactive near-field and the far-field region, wherein the radiation field predominates. Although the radiation is not propagating as a plane wave, the electric and magnetic components can be considered locally normal; moreover, the ratio  $E/H$  can be assumed constant (and almost equal to  $Z_0$ , the intrinsic impedance of free space). This region exists only if the maximum dimension  $D$  of the antenna is large compared with the wavelength  $\lambda$ .

### 6.3.4 Radiating far-field zone

The region of the field where the angular field distribution is essentially independent of the distance from the antenna and the radiated power density [ $\text{W}/\text{m}^2$ ] is constant. The inner boundary of the radiating far-field region is defined by the larger value between  $3\lambda$  and  $2D^2/\lambda$  (i.e., the limit is  $2D^2/\lambda$  if the maximum dimension  $D$  of the antenna is large compared with the wavelength  $\lambda$ ). In the far-field region the field components are transverse and propagate as a plane wave.

The above regions are shown in Figure 1 (where  $D$  is supposed to be large compared with the wavelength  $\lambda$ ).

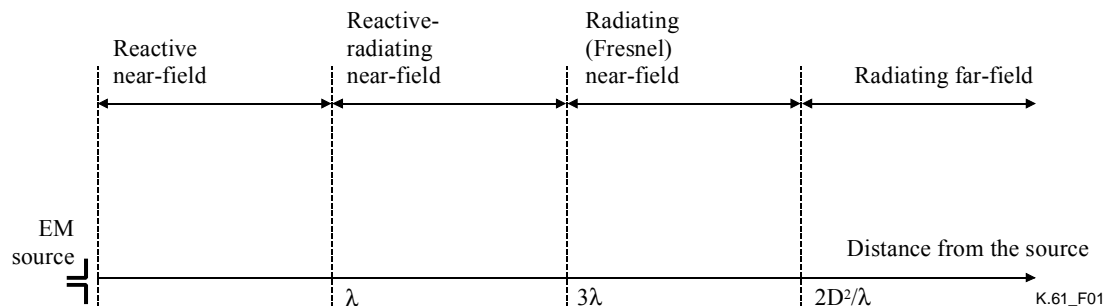

**Figure 1 – Field regions around an EM source  
(the antenna maximum dimension  $D$  is supposed to  
be large compared with the wavelength  $\lambda$ )**

**Table 1 – Main properties of electromagnetic field in different field regions**

	Reactive near-field	Reactive-radiating near-field	Radiating near-field	Radiating far-field
Inner boundary	0	$\lambda$	$3\lambda$	$\text{Max}(3\lambda; 2D^2/\lambda)$
Outer boundary	$\lambda$	$3\lambda$	$\text{Max}(3\lambda; 2D^2/\lambda)$	$\infty$
Power density $S$ [W/m <sup>2</sup> ]	$S \leq  E  H $	$S \leq  E  H $	$S \leq  E  H $ $= \frac{ E ^2}{Z_0} = Z_0  H ^2$	$S =  E  H $ $= \frac{ E ^2}{Z_0} = Z_0  H ^2$
$E \perp H$	No	No	Locally	Yes
$Z = E/H$	$\neq Z_0$	$\neq Z_0$	$\approx Z_0$	$= Z_0$

#### 6.4 Shadowing and scattering

The EMF strength varies with spatial position due to the effect of reflection and scattering about adjacent conducting structures. The scale of this variability is a function of the wavelength. It is important to consider this variability to determine the locations of maximum exposure and use spatial averaging as appropriate.

Since the exposure standards specify the limits on the exposure of the human body, the effect of the body on the field pattern should be considered. For example, Figure 2 shows a situation where the presence of a human body would absorb the incident wave creating a shadow region that precludes a reflection that would otherwise enhance the field at the position of the body. These types of effects, especially at the microwave frequencies, can lead to an overestimation of the field during measurements or numerical calculations near reflecting objects.

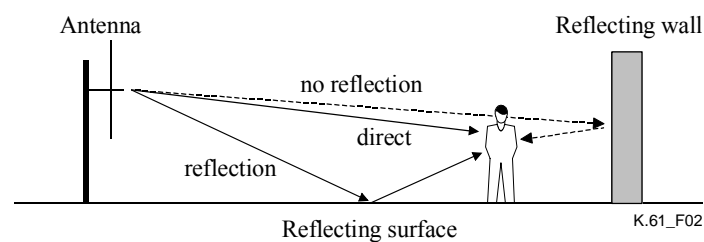

**Figure 2 – An illustration of a multi-path alteration due to the presence of a human body**

#### 6.5 Variability of the source

Telecommunication sources are sometimes variable. Variability of transmitted power and antenna pattern is especially important. This variability presents a special challenge for measurements since the exact state of the transmitter at the time of measurement may not be known.

### **6.5.1 Power variability**

The exposure assessment must take into account the maximum total radiated power from the transmitter. The power transmitted in a telecommunication system could vary due to APC or channel use variability. APC adjusts output power to compensate for adverse propagation conditions. Channel variability falls into two categories:

- 1) Dynamic channel allocation where the channels are turned on or off as needed; or
- 2) Variation in channel occupancy, where the amount of data transmitted over a channel varies; however, even if no data is transmitted, the channel carrier remains. Channel occupancy variation affects the modulation of the signal, however, this effect is expected to be small.

### **6.5.2 Antenna variability**

Although less common than power variability, certain telecommunication systems use active antennas that can dynamically vary their radiation pattern.

### **6.5.3 Intermittent sources**

Certain sources used in telecommunications are intermittent. Such sources emit RF energy only if they need to transmit some information.

Such sources may operate in a regular manner, transmitting data at regular intervals or to a defined schedule.

Such sources may also operate in an irregular manner, transmitting data only if activated by an operator or if a sufficient amount of data has been accumulated to trigger transmission.

## **7 Measurements**

### **7.1 Measurement instrumentation**

#### **7.1.1 Characteristics**

The following general characteristics among measurement devices are important in their selection.

##### **7.1.1.1 Frequency range**

There are two classes: broadband and narrow-band.

- 1) Broadband devices (such as the commonly used electric and magnetic probes) do not give information on frequency spectrum. Nevertheless, frequency-selective measurements on large bands are possible by using small broadband antenna (e.g., bi-conical, horn, etc.) or more sophisticated and expensive devices.
- 2) Narrow-band devices are generally antennas with flat antenna factors over limited spectrum ranges (e.g., the dipole antennas) and can be used for frequency-selective measurement.

##### **7.1.1.2 Antenna directivity**

The antenna response may be isotropic or directional.

For isotropic devices, the response is expected to be independent of the direction of the incident EMF.

For directional devices, the response is expected to be dependent of the direction of the incident EMF. Directional devices are generally polarized and have an axial symmetry in the radiation pattern. Thus proper orientation of the device in 3 orthogonal axes are necessary for the field reconstruction.

### 7.1.1.3 Quantity measured

The majority of devices measure either the electric field or the magnetic field.

The distinction is important in case of reactive field region.

In the far-field region, it is possible to measure either the electric or the magnetic field component and determine the equivalent power density. However, measurement devices for the electric field component are usually preferred. The equivalent power density within the far-field region is obtained from the measured field by calculation, as shown in Table 1.

### 7.1.2 Device selection

The choice of devices for EMF measurement is determined by some factors, for instance:

- the existing standard to be complied with (e.g., limits may be frequency-dependent);
- the number and the characteristics of EMF sources; and
- the field regions (i.e., reactive near-field, radiating near-field, far-field) in which the measurements are made.

The choice of measurement equipment is strongly related to the measurement procedure. The accuracy of measurement results depends on measurement procedures as well as on the characteristics of the measurement instruments used.

A total expanded measurement uncertainty with a 95% confidence level (coverage factor  $k = 1.96$ ) less than or equal to 4 dB is deemed sufficient to show compliance.

It is also recommended that the expanded uncertainty taking into account measurement equipment uncertainty (calibration of probe/meter, probe isotropy, linearity, frequency response, thermal) and measurement methodology uncertainty (meter reading variability, location of field probe, body reflections) is less than or equal to 3 dB.

If the measurement uncertainty exceeds 4 dB, the limit values should be reduced by one half of the margin by which the uncertainty exceeds 4 dB so that the compliance is given by:

$$X_{meas} \leq X_{lim} - \frac{1}{2}(U - 4)$$

where:

$U$  is the measurement uncertainty

$X_{lim}$  is the limit value

$X_{meas}$  is the measured value

### 7.1.3 Calibration requirements

#### 7.1.3.1 Calibration factor

For broadband probes, the calibration factor, CF, is defined by the following formula:

$$CF = \frac{E_{ref}}{E_{meas}}$$

It is the ratio between the expected electric reference field strength ( $E_{ref}$ ) and the value ( $E_{meas}$ ) read on the PC or on a dedicated receiver unit. This factor is mainly a function of frequency and, in the presence of non-linearity error, of field strength. The CF is determined as a frequency function. For each frequency, the CF value shall be known with uncertainty less than 1 dB. Errors due to frequency interpolation are included in the tolerable uncertainty on CF.

### 7.1.3.2 Antenna factor

The antenna factor (AF) is defined for antennas and frequency-selective probes as the ratio:

$$AF = \frac{E_{ref}}{V} [m^{-1}]$$

where  $E_{ref}$  [V/m] is the electric field strength on the probe and  $V$  [V] is the voltage measured on the spectrum analyser. This factor is primarily a function of frequency but, in the presence of non-linearity error, it may depend on field strength, too. The AF is determined as a frequency function. For each frequency, the AF value shall be known with an expanded uncertainty (i.e., 95% statistical confidence) of less than 2 dB. The maximum tolerable uncertainty includes also the error due to frequency interpolation (when needed).

### 7.1.3.3 Isotropy

An isotropic probe is almost always useful in compliance measurement for a telecommunication installation. The isotropic response is usually achieved by a three-axial antenna system, where the three axes are arranged to be mutually orthogonal. The deviation from an ideal isotropic response is measured in the isotropy test. The deviation is called isotropic error and in general it is a function of the incident wave direction. It can be evaluated:

- by measuring the difference from a cosine response of each axis if they are clearly spatially identified and a signal from each axis is available; or
- by checking the whole probe response, if it is not possible to clearly define the position of each axis or a single axis signal is not available.

Mean deviation from the isotropic response should be less than 1 dB.

### 7.1.3.4 Linearity

A linear response versus the field amplitude is required: a linearity error would mean that the antenna and the calibration factors are functions of the test field strength. Thus, the linearity test should be the starting point of the whole characterization process of the probe. The test is carried out, in as wide as possible a dynamic range, by verifying the relationship between radiated power and electric field or voltage measured. The relationship is linear in logarithmic units: the uncertainty band on the linear regression shall have the same magnitude of the measurement uncertainty. If the condition is not fulfilled, a linearity error is probable and the following actions are suggested:

- in the characterization process: CF or AF are measured for different amplitudes of the test wave and different results are obtained;
- in the compliance survey: differences due to field strength can be managed by widening the measurement uncertainty or by considering different factors for different field amplitudes (when it is possible).

Checking the linearity at some frequencies may be useful. Maximum tolerable deviation from a linear response is 1 dB.

### 7.1.3.5 Pulsed signal

Due to their modulation, and their multiple-media access, radio-mobile digital systems have pulsed transmissions. Therefore, when the characterization is carried out with a continuous wave test field, it is necessary to verify if a pulsed test field introduces any changes in the tested characteristics.

If differences on CF and AF, as determined by pulsed test wave and continuous wave, are less than the relevant uncertainties, the measurement instruments can be used without regard for the type of signal they are measuring.



### 7.1.3.6 Multiple signal integration

Verifying the correct integration of different signals with different frequencies is an important test on non-selective broadband probes. It means verifying that the measurement result is correctly given by an RMS formula:

$$E_{rms} = \sqrt{\sum_i E_i^2}$$

The test can be easily carried out with two RF sources: results shall comply with the condition:

$$20 \log_{10} \left\{ \frac{\left| E_{mes} - \sqrt{E_1^2 + E_2^2} \right|}{E_{mes}} \right\} < 0.5 \text{ dB}$$

where:

$E_{mes}$  is the measured electric field

$E_1$  and  $E_2$  are the actual field values

or less than the measurement uncertainty on the electric field or voltage.

### 7.1.3.7 Axial rejection

The response of an axis irradiated by a cross-polarized incident wave is measured in the test. A low axial rejection could have important effects on the electric field strength measurement when it is determined as the RMS value of three orthogonal components.

## 7.2 Evaluation of measurement uncertainties

Measurement uncertainties for measurements of fields are the results of errors due to system instrumentation, field probe response and calibration, and the extrapolation, interpolation and integration algorithms used to determine the averaged field. For evaluation and expression of uncertainties, see [ISO/IEC GUM], [IEC 62311], [EN 50383], [EN 50400] and [b-IEC 62232], [b-FprEN 50492], [b-FprEN 50413] and [b-IEEE P.1597.1].

## 7.3 Probe selection

### 7.3.1 Probe size

If measurements in the near field are being made, the dimension of the probe sensor should be less than one wavelength at the highest operating frequency.

### 7.3.2 Frequency range

General consideration: use broadband wherever possible (it is simpler and shorter), but often a frequency-selective measurement is required (in general, when it is not possible to distinguish one main source and when the measurement results need an elaboration to be compared with an RMS limit).

Selective measurement is usually necessary in case of:

- multiple sources with different limits;
- multiple sources to which different measurement techniques are recommended (e.g., post-processing for GSM or others); or
- it is necessary to determine relative contribution of multiple sources.

### 7.3.3 Directivity

A non-directional probe is preferred.

## 7.4 Procedures

Before performing a measurement of potentially hazardous EMF, an approximate assessment as described in [ITU-T K.52] should be performed. This will permit an estimate of the expected field strength, the boundaries of the compliance zones, and consequently will help in the selection of appropriate test instruments and test procedures.

## 7.5 Safety precautions

Personnel should take appropriate safety precautions while performing measurements. If measurements are performed in the exceedance zone, precautions specified in [ITU-T K.52] should be followed. Also, precautions against indirect effects, such as contact currents, should be observed.

## 7.6 Field region

What is to be measured (E or H) depends on where (reactive or radiating field) the observer is, and on the field impedance.

- Reactive near-field: measure both the E and H components or evaluate the SAR.
- Reactive radiating near-field: if no information on the field impedance is available, measure both the E and H field; if information on the field impedance is available, it is possible to measure only one field component, provided that conservative results are obtained:
  - Measure only E component if  $\frac{E}{H} > Z_0 = 120 \times \pi [\Omega]$  i.e., high impedance EMF
  - Measure only H component if  $\frac{E}{H} < Z_0 = 120 \times \pi [\Omega]$  i.e., low impedance EMF
- Radiating near-field: measure only the E component, the free space impedance ( $Z_0$ ) is assumed (differences are small compared with the measurement uncertainties).
- Radiating far-field: measure only E component.

For exposure at positions located very close to the source, determining the SAR instead of field measurement may be preferable.

## 7.7 Multiple sources

The effects of multiple sources operating at different frequencies should be considered according to ICNIRP or the applicable RF exposure standard, usually in a weighted sum, where each individual source is pro-rated according to the limit applicable to its frequency.

## 7.8 Time and spatial variability

Multi-path reflections can create non-uniform field distributions. Therefore, to assess the whole body human exposure, an averaging process is required. The field values should be determined at N points as described in Figure 3. Three points are basically recommended (Figure 3a), but if accuracy is required the number can be increased to six (Figure 3b), nine (Figure 3c), twenty (Figure 3d), etc., in accordance with national or regional standards and regulations. In all cases, uncertainty of the evaluation should be determined.

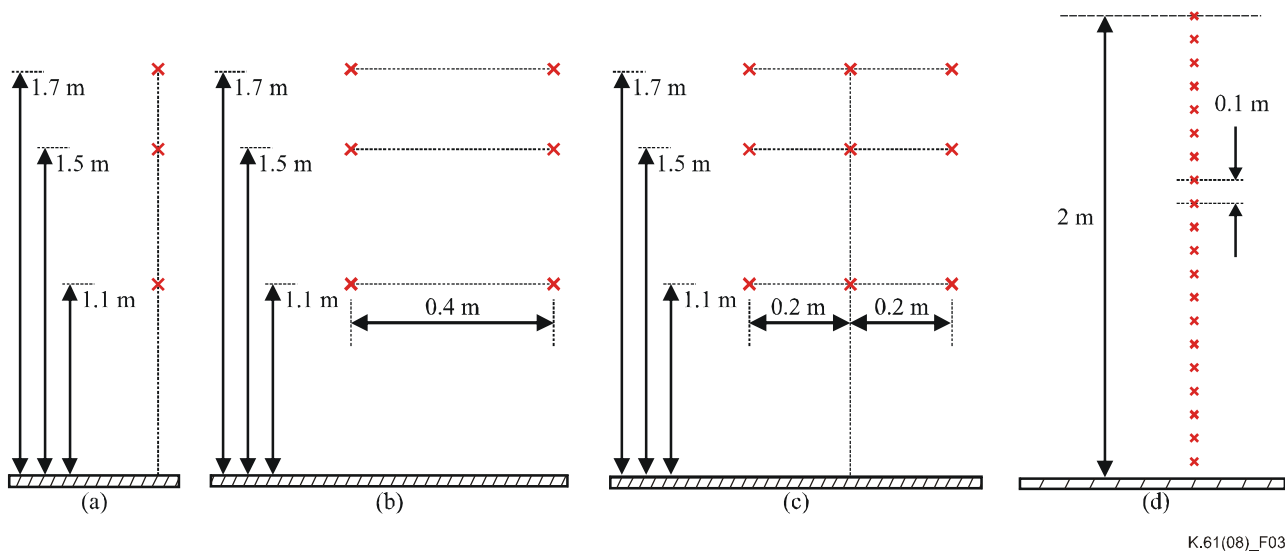

**Figure 3 – Measurement points for spatial averaging**

The formula for calculating spatially averaged field values is as follows:

$$(E \text{ or } H) = \sqrt{\frac{\sum_{i=1}^N (E_i \text{ or } H_i)^2}{N}}$$

where N is the number of points, i.e., three, six, nine, twenty, etc.

Measurement should not be conducted in the close vicinity of metallic objects to avoid coupling with the probe. For example, it may be sufficient to keep the edge of the probe at least 3 "probe lengths" from the metallic object.

In case of multiple sources, the measurement area should be divided into a grid of about one square metre and measurements performed at individual grid points. Large field gradients can exist in the near field of a radiator. Measurements should be performed sufficiently close together to accurately determine the compliance zone boundaries.

In areas of expected time variability of the source, measurements may need to be performed over an extended time period. For example, in case of channel variability, measurements should be made during time of peak usage.

NOTE – Initial measurements in a grid or near the radiator, as described in this clause, yield the maximum point field values. These values represent the most conservative evaluation of the exposure. It is possible to define the compliance zones based on these conservative values. If more refined estimation is desired, spatial averaging, as described in clause 6.1.2, should be used.

## **8 Compliance with the limit: measurement results processing**

### **8.1 Identification of individual sources**

The probe used for external field measurements in determining compliance, generally, should be isotropic, non-directional and non-polarized. Also, the probe should not produce significant scattering of the incident electromagnetic field and the leads from the sensor to the meter should not interact significantly with the field. However, such a probe cannot differentiate between different sources.

Frequency-selective or directional measurements are needed to identify the contribution of individual sources. For example, a combination of antenna and a spectrum analyser allows for a more precise measurement of individual frequency, direction and polarization field components. However, this makes the measurements more complicated as it is necessary to measure and sum three polarizations separately. Also, in complex scattering environments, it may be necessary to measure the fields in various directions. It is also possible to use the antenna and spectrum analyser combination to verify the frequency and origin of the emissions measured by the isotropic probe.

In cases when non-conformity with exposure limits is found, the procedure for the identification of the main source of radiation, according to Appendix II, should be applied.

## 8.2 Intermittent sources

Neither the isotropic wideband probe nor a spectrum analyser can measure the duration of an intermittent source. The field probe measures the maximum (peak) field value, while the spectrum analyser measures the maximum spectral density in the frequency domain. To obtain proper time averaging, the duration of an intermittent transmission has to be determined from the operational requirements of the system.

## 8.3 Base stations for radio-mobile systems

The preferred method for RF EMF measurements for base-station emitters providing mobile wireless telecommunication services is to ensure that all radio channels are occupied during the measurement. This may be verified by the knowledge of the system operation or through examination of the signal with a combination of antenna and spectrum analyser. If measurements with all channels occupied are not possible, then an extrapolation procedure, such as the example provided below, should be used.

The following text provides an example of extrapolation procedure for a channelized mobile wireless system. The extrapolation is based on the measurement of the field strength,  $E_{BCCH}$ , of the base station control channel. The subsequent processing is based on numerical and statistical analysis on power reduction. It is described by the introduction of attenuation factors  $\alpha$ . The following items are possible:

- conservative hypothesis: full traffic ( $\alpha_{traf} = 1$ );
- measurement of the electric field strength due to different wireless systems;
- check of carriers number ( $n_c$ ) for each wireless system;
- definition of  $\alpha_{APC}$  and  $\alpha_{DTX}$  as both statistical and experimental parameters ( $<1$ ): they are attenuation factors due to strategies implemented to reduce the radiated power, i.e., automatic power control (APC) and discontinuous transmission (DTX);
- the total radiated power for each system,  $P_{ext}$ , is extrapolated from the power of the base station control channel,  $P_{BCCH}$ , by the following expression:

$$P_{ext} = P_{BCCH} + (n_c - 1) \times P_{BCCH} \alpha_{APC} \times \alpha_{DTX}$$

- thus, the total electric field strength related to each transmission system is obtained by the square root of the above power formulas:

$$E_{ext} = E_{BCCH} \sqrt{1 + (n_c - 1) \times \alpha_{APC} \times \alpha_{DTX}}$$

For UMTS, other approaches could be followed, according to the signal characteristic. For analogue systems, the power radiated by one carrier is simply multiplied by the number of carriers.

The last step is to calculate the total equivalent electric field strength,  $E_{TOT}$ , that will be compared with the exposure limit. It is obtained by the RMS sum of the contribution from each transmission system (numbered by the index  $k$ ):

$$E_{TOT} = \sqrt{\sum_k E_k^2} \leq E_{lim}(f)$$

and when different limits are defined for different frequencies:

$$\rho_E = \sqrt{\sum_k \frac{E_k^2}{E_{lim_k}^2}} \leq 1$$

Uncertainty: when conservative approximations (e.g., full traffic,  $\alpha_{traf} = 1$ ) are made during processing, the field strength resulting from the post-processing is compared with the exposure limit.

Other extrapolation procedures can be found in Appendix I.

# Appendix I

## Calculation methods

(This appendix does not form an integral part of this Recommendation)

### I.1 General

This appendix provides guidance in selecting calculation methods to assess compliance with EMF levels. There are several methods useful for determining compliance with exposure limits:

- 1) finite-difference time-domain (FDTD);
- 2) multiple-region finite-difference time-domain (MR/FDTD);
- 3) ray tracing model;
- 4) hybrid ray tracing/FDTD methods; and
- 5) near-field antenna models such as method of moments (MOM) and the numeric electromagnetic code (NEC).

The selection of the appropriate numerical method depends on the following factors:

- 1) the field zone where the exposure evaluation is required;
- 2) the quantities being evaluated (SAR or reference fields); and
- 3) the topology of the environment where the exposure occurs.

The selection criteria are summarized in Table I.1:

**Table I.1 – Selection of numerical techniques**

Field zone	Topology	Evaluated quantity	Suitable numerical technique
Near-field	Open	Field	FDTD, MOM
Near-field	Open	SAR	FDTD
Near-field	Closed, multiple scatterers	Field	FDTD, MOM
Near-field	Closed, multiple scatterers	SAR	FDTD, MR/FDTD
Far-field	Open	Field	Ray tracing, MOM
Far-field	Multiple scatterers (complex urban environment)	Field	Ray tracing

### I.2 Methods description

A brief description of the various methods is provided in the following clauses. More information on calculation methods can be found in the following clauses.

#### I.2.1 FDTD

The FDTD method is most useful for exposure assessment in near antenna or in confined locations with complex scattering environment. The FDTD algorithm is the most widely accepted computational method for SAR modelling [b-Kunz]. The FDTD method offers great flexibility in modelling the heterogeneous structures of anatomical tissues and organs.

The FDTD method can be used to predict field values in complex scattering environments by specifying appropriate boundary conditions or to predict SAR by specifying the dielectric properties and dimensions of the human body and appropriate boundary conditions for closed or open spaces (such as Mur, Liao, retarded-time and the perfectly-matched-layers).

A sinusoidal waveform is typically used as the excitation source at the antenna feed-point to perform the computations. The signal is allowed to propagate and interact with the objects modelled in the computational domain by means of numerical iterations. The FDTD algorithm iterates the field propagation in both space and time until the field conditions in the computational domain reach sinusoidal steady state. The total field at selected tissue locations can be computed to determine the SAR. In order to maintain numerical stability for the computational algorithms, the Courant condition that provides the minimum relationship for selecting the time and spatial resolutions in the computation must be used. The iteration speed and expected computational errors are related to the parameters used for meeting the Courant condition.

### **I.2.2 MR/FDTD**

The MR/FDTD algorithm [b-Johnson] overcomes computational inefficiencies of FDTD for geometries that include extensive sparse regions. In MR/FDTD the problem space is divided into several independent subregions distributed in an otherwise free space. The fields in the subregions are determined with the use of localized FDTD lattices.

### **I.2.3 Ray tracing**

Ray tracing is useful for evaluation of fields in large open areas and in urban environments that involve multiple scatterers. A simple two-ray model is used in [ITU-T K.52]. This model is accurate for open unbounded areas over flat earth. More complex scattering environments that involve reflections from buildings, fluctuations in earth elevations, etc., require complicated multi-ray algorithms. The main disadvantage of ray tracing is that it is essentially a far-field technique. Also, it assumes that the size of the scatterer is large compared to the wavelength. Ray tracing is not suitable for calculation at long wavelengths, where diffraction is important. Ray tracing does not enable calculation of the SAR.

### **I.2.4 FDTD/ray tracing**

The hybrid FDTD/ray tracing technique [b-Bernardi] tries to obtain the advantages of both methods. These methods use ray tracing to evaluate the incident field and FDTD to evaluate the SAR in the body.

### **I.2.5 MOM**

The method of moments (MOM) [b-Harrington] is useful for evaluating the field strength emanating from antennas or other types of thin-wire conductive structures, and for computation of the scattered field from thin-wire metallic structures. The use of MOM for computation of scattering from conductive planar surfaces requires that such surfaces be represented by a wire mesh. MOM is useful for near-field and far-field computations. The details of the antenna construction and geometry and the geometry of scattering objects must be known. The MOM is not useful for determining field penetration through dielectric bodies and, therefore, is not suitable for determining SAR. Commercial and non-commercial implementations of MOM are available.

## **I.3 Other near-field models**

The ray tracing algorithms are most useful for exposure sufficiently far from the radiator where the fields reflected from buildings and the unevenness of the terrain are important. In the majority of telecommunication applications, the field drops below the limit values a few metres from the source. Therefore, accurate evaluation of the field near the antenna is required. In addition to MOM described in clause I.2.5, there exist several other methods to evaluate the field if the details of the antenna construction and geometry are known. Such methods can also take into account scattering from objects near the antenna.

#### **I.4 Practical problems**

The main practical problem in application of complex computational techniques, such as ray tracing or NEC is that the geometry needs to be specified precisely. In practice, the biggest obstacle to using even simple two-ray models is lack of adequate information about the antenna and the exposure environment. For example, the available terrain data may have limited resolution. Another example is when the antenna pattern provided by the manufacturer is valid for the far-field region. Near the antenna, the antenna gain may reduce and lobes may shift. One solution for this is to calculate the antenna patterns using MOM if the antenna construction is known.



## Appendix II

### Identification and measurement of the main source of radiation

#### II.1 Treatment of non-conformities – Exceeding the exposure limits

The parameter that determines the compliance, or non-compliance, of a fixed radio station is the level of cumulative exposure which can be measured with a broadband meter. In cases where, in a certain access zone, the level of cumulative exposure exceeds the maximum limit, the level of received energy of each radiant source should be measured using a narrow-band meter. It is necessary to highlight that when the level of cumulative exposure exceeds the limit (100%), it can be due to two reasons:

- Existence of one or several radiant sources whose levels of received energy exceeds the exposure limits corresponding to the operation frequency.
- The level of received energy of each of the involved radiant sources is lower than the exposure limit corresponding to its operation frequency; nevertheless, the combined effect of multiple sources contributes to the level of cumulative exposure being greater than 100%.

Depending on the results of the measurements one of the following cases will apply.

##### II.1.1 Case 1: Existence of one or several radiant sources whose levels of received energy exceeds the respective exposure limits

By use of a narrow-band meter, it can be identified which radiant sources exceed the exposure limit corresponding to the operation frequency. Once identified, these should be adjusted using mitigation techniques.

##### II.1.2 Case 2: The level of received energy of each of the radiant sources involved in the measurement is lower than the exposure limit corresponding to its operation frequency; nevertheless, the level of cumulative exposure is greater than 100%

In this case, the level of cumulative exposure is greater than the limit (100%), even when the radiant sources, previously identified in the case 1, emit an electromagnetic field lower than its respective exposure limit. For such a reason, it is necessary to select the sources that contribute the greatest energy, depending on the selection approach. Once identified, these should be adjusted using mitigation techniques.

#### II.2 Confirmation measurement

Following the employment of the mitigation techniques, it should be verified that the level of cumulative exposure does not exceed 100%.

## Bibliography

In the course of the development of this Recommendation, the documents listed below have been considered as valuable inputs. They are listed because they were not formally adopted at the time when this Recommendation has been approved. However, users of this Recommendation are encouraged to investigate the latest status of the draft standards listed below and identify if they would also apply in the context of the exposure assessment they are conducting.

- [b-IEC 62232] IEC Draft 62232 (2008), *Determination of RF fields in the vicinity of mobile communication base stations for the purpose of evaluating human exposure – Part 1: Frequency range 300 MHz to 6 GHz*.  
<<http://www.iec.ch/cgi-bin/procgi.pl/www/iecwww.p?wwwlang=english&wwwprog=pro-det.p&progdb=db1&He=IEC&Pu=62232&Pa=&Se=&Am=&Fr=&TR=&Ed=1>>
- [b-FprEN 50492] CENELEC Draft FprEN 50492 (2008), *Basic standard for the in-situ measurement of electromagnetic field strength related to human exposure in the vicinity of base stations*.  
<[http://tcelis.cenelec.be/pls/portal30/CELISPROC.RPT\\_WEB\\_PROJECT\\_D.SHOW?p\\_arg\\_names=project\\_number&p\\_arg\\_values=14408](http://tcelis.cenelec.be/pls/portal30/CELISPROC.RPT_WEB_PROJECT_D.SHOW?p_arg_names=project_number&p_arg_values=14408)>
- [b-FprEN 50413] CENELEC Draft FprEN 50413 (2007), *Basic standard on measurement and calculation procedures for human exposure to electric, magnetic and electromagnetic fields (0 Hz – 300 GHz)*.  
<[http://tcelis.cenelec.be/pls/portal30/CELISPROC.RPT\\_WEB\\_PROJECT\\_D.SHOW?p\\_arg\\_names=project\\_number&p\\_arg\\_values=14409](http://tcelis.cenelec.be/pls/portal30/CELISPROC.RPT_WEB_PROJECT_D.SHOW?p_arg_names=project_number&p_arg_values=14409)>
- [b-IEEE P1597.1] IEEE P1597.1 (2008), *Draft Standard for Validation of Computational Electromagnetics (CEM) Computer Modeling and Simulations*.  
<[http://ieeexplore.ieee.org/xpls/abs\\_all.jsp?tp=&isnumber=4588276&arnumber=4588277&punumber=4588275](http://ieeexplore.ieee.org/xpls/abs_all.jsp?tp=&isnumber=4588276&arnumber=4588277&punumber=4588275)>
- [b-ICNIRP] ICNIRP (1998), *Guidelines for limiting exposure to time-varying electric, magnetic, and electromagnetic fields (up to 300 GHz)*, Health Physics, Vol. 79, No. 4, pp. 494-522.
- [b-Harrington] Harrington R.F. (1993), *Field Computation by Moment Methods*, Wiley-IEEE Press.
- [b-Kunz] Kunz K.S., Luebbers R.J., (1993), *The Finite Difference Time Domain Method for Electromagnetics*, CRC Press.
- [b-Johnson] Johnson J.M., Rahmat-Samii Y., (1997), *MR/FDTD: A multiple-region finite-difference – time-domain method*, Microwave and Optical Technology Letters, Vol. 14, No. 2, pp. 101-105.
- [b-Bernardi] Bernardi P., Cavagnaro M., Pisa S., Piuze E. (2000), *Human Exposure to Radio Base-Station Antennas in Urban Environment*, IEEE Transactions on Microwave Theory and Techniques, Vol. 48, No. 11, pp. 1996-2002.
- [b-FDTD] Bernardi P., Cavagnaro M., D'Atanasio P., Di Palma E., Pisa S. and Piuze E., (2002), *FDTD, multiple-region/FDTD, ray-tracing/FDTD: a comparison on their applicability for human exposure evaluation*, International Journal on Numerical Modeling, Vol. 15, No. 5-6, pp. 579-593.
- [b-Mur] Mur G., (1981), *Absorbing Boundary Conditions for the Finite-Difference Approximation of the time-Domain electromagnetic Field Equations*, IEEE Transactions on Electromagnetic Compatibility, Vol. EMC-23, No. 4, pp. 377-382.

[b-Faraone] Faraone A., Yew-Siow Tay R., Joyner K.H., Balzano Q., (2000), *Estimation of the Average Power Density in the Vicinity of Cellular Base Station Collinear Array Antennas*, IEEE Transaction on Vehicular Technology, Vol. 49, No. 3, pp. 984-996.





## SERIES OF ITU-T RECOMMENDATIONS

Series A	Organization of the work of ITU-T
Series D	General tariff principles
Series E	Overall network operation, telephone service, service operation and human factors
Series F	Non-telephone telecommunication services
Series G	Transmission systems and media, digital systems and networks
Series H	Audiovisual and multimedia systems
Series I	Integrated services digital network
Series J	Cable networks and transmission of television, sound programme and other multimedia signals
<b>Series K</b>	<b>Protection against interference</b>
Series L	Construction, installation and protection of cables and other elements of outside plant
Series M	Telecommunication management, including TMN and network maintenance
Series N	Maintenance: international sound programme and television transmission circuits
Series O	Specifications of measuring equipment
Series P	Telephone transmission quality, telephone installations, local line networks
Series Q	Switching and signalling
Series R	Telegraph transmission
Series S	Telegraph services terminal equipment
Series T	Terminals for telematic services
Series U	Telegraph switching
Series V	Data communication over the telephone network
Series X	Data networks, open system communications and security
Series Y	Global information infrastructure, Internet protocol aspects and next-generation networks
Series Z	Languages and general software aspects for telecommunication systems