

International Telecommunication Union

ITU-T

TELECOMMUNICATION
STANDARDIZATION SECTOR
OF ITU

K.72

(04/2008)

SERIES K: PROTECTION AGAINST INTERFERENCE

**Protection of telecommunication lines using
metallic conductors against lightning – Risk
management**

Recommendation ITU-T K.72



Recommendation ITU-T K.72

Protection of telecommunication lines using metallic conductors against lightning – Risk management

Summary

Recommendation ITU-T K.72 gives the methodology for evaluating the need for protection measures against lightning of telecommunication lines using metallic conductors.

This method is based on the risk assessment: protection measures are necessary when the risk is greater than the tolerable risk. Maximum value of the tolerable risks is suggested.

This Recommendation considers the risk of loss of service of the telecommunication network.

The risk is evaluated through the risk components caused by lightning, which is the source of damage on telecommunication line as a function of the striking point with respect to the telecommunication line (lightning flashes direct to the line, near the line, or directly to the structures connected at the ends of the line).

This Recommendation shall be used together with Recommendation ITU-T K.47, which provides the risk assessment and the protection measures against lightning flashes direct to the telecommunication line and to structures connected at the ends of the telecommunication line, and Recommendation ITU-T K.46, which provides the risk assessment and the protection measures against lightning flashes near the telecommunication line.

Source

Recommendation ITU-T K.72 was approved on 13 April 2008 by ITU-T Study Group 5 (2005-2008) under Recommendation ITU-T A.8 procedure.

Keywords

Lightning, node, protection, risk, risk assessment, SPD, surge, telecommunication line.

FOREWORD

The International Telecommunication Union (ITU) is the United Nations specialized agency in the field of telecommunications, information and communication technologies (ICTs). The ITU Telecommunication Standardization Sector (ITU-T) is a permanent organ of ITU. ITU-T is responsible for studying technical, operating and tariff questions and issuing Recommendations on them with a view to standardizing telecommunications on a worldwide basis.

The World Telecommunication Standardization Assembly (WTSA), which meets every four years, establishes the topics for study by the ITU-T study groups which, in turn, produce Recommendations on these topics.

The approval of ITU-T Recommendations is covered by the procedure laid down in WTSA Resolution 1.

In some areas of information technology which fall within ITU-T's purview, the necessary standards are prepared on a collaborative basis with ISO and IEC.

NOTE

In this Recommendation, the expression "Administration" is used for conciseness to indicate both a telecommunication administration and a recognized operating agency.

Compliance with this Recommendation is voluntary. However, the Recommendation may contain certain mandatory provisions (to ensure e.g. interoperability or applicability) and compliance with the Recommendation is achieved when all of these mandatory provisions are met. The words "shall" or some other obligatory language such as "must" and the negative equivalents are used to express requirements. The use of such words does not suggest that compliance with the Recommendation is required of any party.

INTELLECTUAL PROPERTY RIGHTS

ITU draws attention to the possibility that the practice or implementation of this Recommendation may involve the use of a claimed Intellectual Property Right. ITU takes no position concerning the evidence, validity or applicability of claimed Intellectual Property Rights, whether asserted by ITU members or others outside of the Recommendation development process.

As of the date of approval of this Recommendation, ITU had not received notice of intellectual property, protected by patents, which may be required to implement this Recommendation. However, implementers are cautioned that this may not represent the latest information and are therefore strongly urged to consult the TSB patent database at <http://www.itu.int/ITU-T/ipr/>.

© ITU 2009

All rights reserved. No part of this publication may be reproduced, by any means whatsoever, without the prior written permission of ITU.

CONTENTS

| | Page |
|-------------------------------------------------------------------------------|-------------|
| 1 Scope | 1 |
| 2 References..... | 1 |
| 3 Definitions | 2 |
| 4 Abbreviations and acronyms | 3 |
| 5 Reference configuration..... | 4 |
| 6 Explanation of terms..... | 5 |
| 6.1 Damage and loss..... | 5 |
| 6.2 Risk and risk components..... | 6 |
| 6.3 Composition of risk components related to a telecommunication network ... | 7 |
| 7 Risk management | 7 |
| 7.1 Basic procedure | 7 |
| 7.2 Tolerable risk R_T | 7 |
| 7.3 Specific procedure to evaluate the need for protection | 7 |
| 7.4 Protection measures..... | 8 |
| 7.5 Selection of protection measures..... | 8 |

Introduction

Lightning flashes to earth may be hazardous to telecommunication networks.

The hazard to telecommunication networks can result in:

- injury of people inside the structures connected to the telecommunication line;
- physical damage (e.g., cable destruction) to the telecommunication line;
- failure (e.g., insulation breakdown) of the telecommunication line;
- failure of the associated electrical and electronic equipment inside the structure (i.e., exchange, customer's building, or remote electronic site).

To reduce the loss due to lightning, protection measures may be required. Whether they are needed, and to what extent, should be determined by the risk assessment.

The risk, defined in this Recommendation as the probable average annual service loss in a telecommunication network due to lightning flashes, depends on:

- the annual number of lightning flashes influencing the telecommunication line;
- the probability of damage by one of the influencing lightning flashes;
- the mean amount of consequential loss.

Lightning flashes influencing the telecommunication line may be divided into:

- flashes terminating on the telecommunication line;
- flashes terminating near the telecommunication line;
- flashes direct to a structure connected to the telecommunication line.

Flashes to a telecommunication line may cause physical damage. Flashes near the telecommunication line, as well as flashes to a structure connected to a telecommunication line, may cause failure of the telecommunication line and of electrical and electronic systems inside the structures due to overvoltages resulting from resistive and inductive coupling of these systems with the lightning current.

The number of lightning flashes influencing the telecommunication network depends on the dimensions and the characteristics of the telecommunication network, on the environment characteristics, as well as on lightning ground flash density in the region where the telecommunication network is located.

The probability of lightning damage depends on the telecommunication network, on the lightning current characteristics, as well as on the type and efficiency of applied protection measures.

The annual mean amount of the consequential loss depends on the extent of damage and the consequential effects which may occur as result of a lightning flash.

The effect of protection measures results from the features of each protection measures and may reduce the damage probabilities or the amount of consequential loss.

The assessment of risk due to all possible effects of lightning flashes to telecommunication networks is given in this Recommendation.

The decision to provide lightning protection may be taken regardless of the outcome of any risk assessment where there is a desire that there be no avoidable risk.

Recommendation ITU-T K.72

Protection of telecommunication lines using metallic conductors against lightning – Risk management

1 Scope

This Recommendation deals with the risk management of lightning protection of telecommunication networks using cables with metallic conductors.

The risk assessment is limited to physical damage and failure of insulation of telecommunication lines (buried or aerial cables, shielded or unshielded cables) which can cause the loss of service.

This Recommendation provides a procedure for the evaluation of such a risk. Once an upper tolerable limit for the risk has been selected, this procedure allows the selection of appropriate protection measures to be adopted to reduce the risk to a level at or below the tolerable limit.

This Recommendation shall be used together with [ITU-T K.47], which provides the risk assessment and the protection measures against lightning flashes to the telecommunication line and to structures connected to the telecommunication line, and [ITU-T K.46], which provides the risk assessment and the protection measures against lightning flashes near the telecommunication line.

The protection need for line equipment (such as multiplexers, power amplifiers, optical network units) and line termination equipment is not considered in this Recommendation and it should be evaluated using the risk assessment applied to the structure where the equipment is located (i.e., exchange, customer's building, or remote electronic site).

The protection of persons using telecommunication equipment inside the customer's structure, from dangerous situations caused by touch voltages is outside the scope of this Recommendation and it should be evaluated using the risk assessment applied to the customer's structure.

2 References

The following ITU-T Recommendations and other references contain provisions which, through reference in this text, constitute provisions of this Recommendation. At the time of publication, the editions indicated were valid. All Recommendations and other references are subject to revision; users of this Recommendation are therefore encouraged to investigate the possibility of applying the most recent edition of the Recommendations and other references listed below. A list of the currently valid ITU-T Recommendations is regularly published. The reference to a document within this Recommendation does not give it, as a stand-alone document, the status of a Recommendation.

- [ITU-T K.46] Recommendation ITU-T K.46 (2008), *Protection of telecommunication lines using metallic symmetric conductors against lightning-induced surges.*
- [ITU-T K.47] Recommendation ITU-T K.47 (2008), *Protection of telecommunication lines using metallic conductors against direct lightning discharges.*
- [ITU-T K.60] Recommendation ITU-T K.60 (2008), *Emission levels and test methods for wireline telecommunication networks to minimize electromagnetic disturbance of radio services.*
- [IEC 62305-2] IEC 62305-2 (2006), *Protection against lightning – Part 2: Risk management.*
<<http://webstore.iec.ch/webstore/webstore.nsf/artnum/035440>>

3 Definitions

This Recommendation defines the following terms:

3.1 dangerous event: Lightning flash to or near the telecommunication line to be protected which causes a dangerous surge voltage due to lightning.

3.2 dangerous surge voltage due to lightning: A surge voltage whose peak value U_p is greater than the equipment resistibility or the conductor insulation surge voltage withstand level of the telecommunication line.

3.3 electronic system: System incorporating sensitive electronic components such as communication equipment, computers, control and instrumentation systems, radio systems, power electronic installations.

3.4 failure of electrical and electronic systems: Permanent damage of electrical and electronic systems due to surges.

3.5 lightning flash near a line: Lightning flash striking close enough to a line to be protected that it may cause dangerous surges.

3.6 lightning flash to a structure connected to the line to be protected: Lightning flash striking the structure connected to the line to be protected.

3.7 line to be protected: Line connected to a structure for which protection is required against the effects of lightning in accordance with this Recommendation.

3.8 loss L_X : Annual mean amount of loss (humans and goods) consequent to a specified type of damage due to a dangerous event, relative to the total value (humans and goods) of the object to be protected.

3.9 metallic symmetric conductors: Transmission media consisting of a pair of twisted wires balanced with respect to earth, usually assembled in groups in order to form a telecommunication cable.

3.10 node: Point between sections of a telecommunication line.

NOTE – The list of nodes on a telecommunication installation is shown in the reference configuration (clause 5).

3.11 physical damage: Damage to a telecommunication line due to mechanical and thermal effects of lightning.

3.12 protection measures: Measures to be adopted in the telecommunication installation to be protected to reduce the risk.

3.13 risk component R_X : Partial risk depending on the source and the type of damage.

3.14 risk of loss of service R'_2 : Value of probable average annual loss of service due to lightning, relative to the total value of service of the telecommunication installation to be protected.

NOTE – The risk R_2 , used by [IEC 62305-2], refers to the risk of loss of service related to a structure.

3.15 risk R : Value of probable average annual loss (humans and goods) due to lightning, relative to the total value (humans and goods) of the object to be protected.

3.16 section of a telecommunication line S_S : Part of a telecommunication line with homogeneous characteristics where only one set of parameters is involved in the assessment of a risk component.

3.17 source of damage: The source of damage depends on the position of the point of strike relative to the considered line:

- Source of damage S_1 : Flashes to the structure (the exchange, the customer's building, or remote site) where the telecommunication or the signalling line enters;

- Source of damage S2: Flashes near the structure (the exchange, the customer's building, or remote site) where the telecommunication or the signalling line enters;
- Source of damage S3: Flashes to the telecommunications line entering the structure (the exchange, the customer's building, or remote site);
- Source of damage S4: Flashes near the telecommunication line entering the structure (the exchange, the customer's building, or remote site).

3.18 surge: Temporary excessive voltage or current, or both, coupled on a telecommunication line from an external electrical source.

NOTE 1 – Typical electrical sources are lightning and AC/DC power systems.

NOTE 2 – Electrical source coupling can be one or more of the following: electric field (capacitive), magnetic field (inductive), conductive (resistive), electromagnetic field.

3.19 surge due to lightning: A surge which is caused by lightning through any type of electromagnetic (conductive, inductive and capacitive) coupling.

NOTE – It is characterized by the following five parameters: peak value; front time, T_1 , and time to half value, T_2 (or time parameters T_1/T_2); steepness; and specific energy.

3.20 surge protective device (SPD): Device that restricts the voltage of a designated port or ports, caused by a surge, when it exceeds a predetermined level.

- 1) Secondary functions may be incorporated, such as a current-limiting device to restrict a terminal current.
- 2) Typically, the protective circuit has at least one non-linear voltage-limiting surge protective component.
- 3) An SPD is a combination of a protection circuit and holder.

3.21 telecommunication installation: A combination of equipment, systems, finished products and/or components assembled and/or erected by an assembler/installer at a given place to operate together in order to provide telecommunication services.

3.22 telecommunication line: Transmission medium intended for communication between equipment that may be located in separate structures, such as a phone line and a data line.

3.23 telecommunication network [ITU-T K.60]: Entirety of equipment (comprising any combination of the following: network cable, telecommunication terminal equipment, and telecommunication system or installation) that are indispensable to ensure normal intended operation of the telecommunication network.

3.24 tolerable risk R_T : Maximum value of the risk which can be tolerated for the object to be protected.

4 Abbreviations and acronyms

This Recommendation uses the following abbreviations and acronyms:

| | |
|-------|----------------------------------------------------|
| C | Node between buried and aerial cables |
| D | Node between shielded and unshielded aerial cables |
| DSLAM | Digital Subscriber Line Access Multiplier |
| E | Exchange |
| MDF | Main Distribution Frame |
| MET | Main Earthing Terminal |
| NT | Network Termination |

| | |
|-----|------------------------------------------------------------------|
| P | Node between paper-insulated and plastic-insulated buried cables |
| R | Remote electronic site |
| S | Customer |
| SPD | Surge Protective Device |

5 Reference configuration

The telecommunication network to be considered is the physical connection between:

- the switch telecommunication building and the customer's building; or
- two switch telecommunication buildings; or
- two customer's buildings.

The telecommunication network to be protected using this Recommendation is limited to telecommunication lines (buried or aerial cables, shielded or unshielded cables).

Figure 1 shows the reference configurations for the telecommunication lines using metallic symmetric conductors, where the nodes and the cable sections between them can be seen.

The nodes of Figure 1 have the following description (as indicated in clause 4 of [ITU-T K.46]):

Node E : Entrance of the exchange building, e.g., main distribution frame (MDF).

Node P: Transition between paper-insulated and plastic-insulated buried cables.

Node C: Transition between buried and aerial cables.

Node R: Entrance of remote electronic sites with active equipment, e.g., DSLAM.

Node D: Transition between shielded and unshielded aerial cables.

Node S: Entrance of the customer's building.

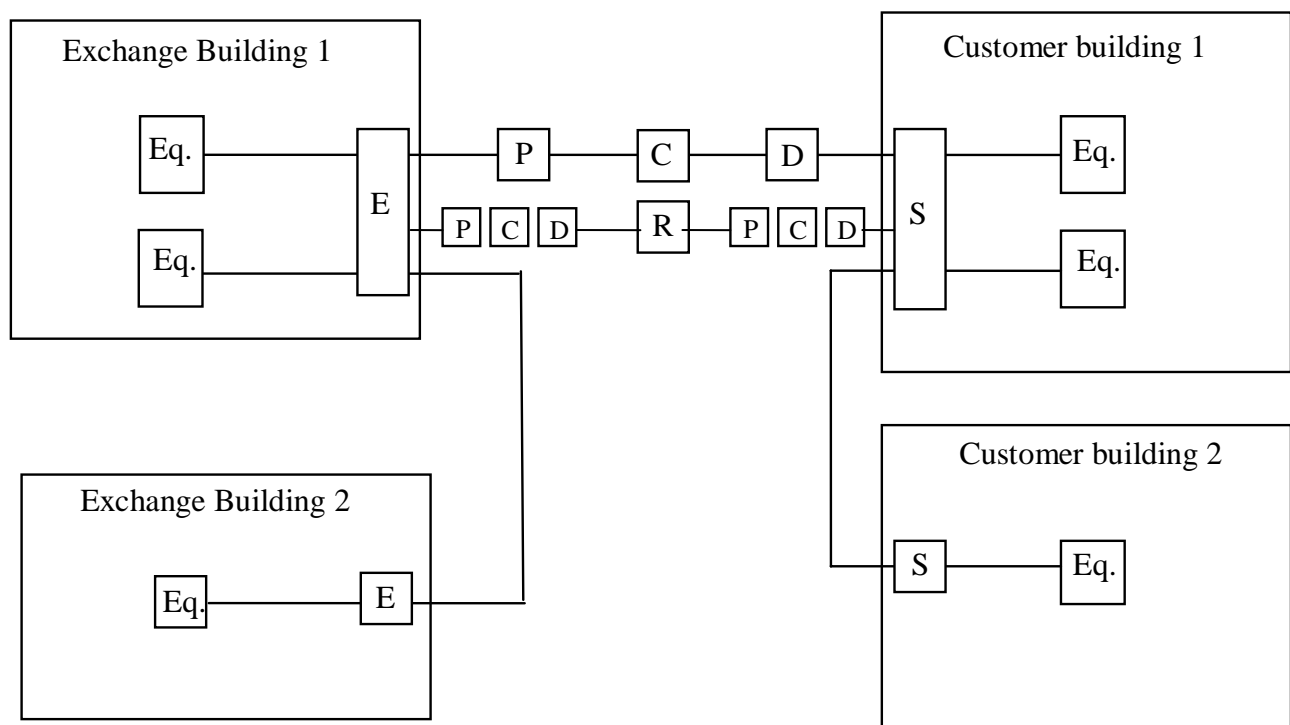

Figure 1 – Reference configuration

6 Explanation of terms

6.1 Damage and loss

6.1.1 Source of damage

The lightning current is the primary source of damage.

In general, the following sources are distinguished by the strike attachment point (Figure 2):

S₁: Flashes to a structure.

S₂: Flashes near a structure.

S₃: Flashes to a service (which includes a telecommunication line).

S₄: Flashes near a service (which includes a telecommunication line).

| Source of damage | Striking point |
|------------------|-------------------------------------------------------------------------------------|
| S1 |  |
| S3 |  |
| S2 |  |
| S4 |  |

Figure 2 – Lightning as source of damage

6.1.2 Types of damage to a telecommunication network

A lightning flash may cause damage depending upon the characteristics of the telecommunication network to be protected. Some of the most important characteristics are: type of construction, type of service, and provided protection measures.

In general, for practical applications of the risk assessment, it is useful to distinguish between four basic types of damage which can appear as the consequence of lightning flashes. They are as follows:

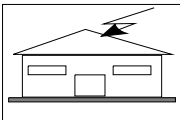
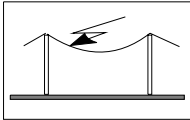
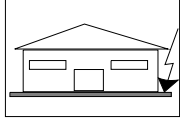
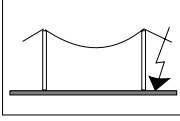
D1: Injury to living beings.

D2: Physical damage.

D3: Failure of telecommunication line insulation.

D4: Failure of electrical and electronic systems.

Lightning affecting a telecommunication network can cause damage to the physical line itself, used to provide the service, as well as to related electrical and electronic systems.

The damage may also extend to internal systems connected to the telecommunication line.

The injury to living beings can be only caused to people inside the structures (network staff are advised not to work on the installation during lightning storms) and is covered by the risk assessment of loss of human life applied to the structure. Therefore, this injury is not considered in the risk assessment of the telecommunication network.

6.1.3 Types of loss

Each type of damage, alone or in combination with others, may produce a different consequential loss in the object to be protected. The type of loss that may appear depends on the characteristics of the object to be protected.

In general, the following types of loss shall be taken into account:

- L₁: Loss of human life.
- L₂: Loss of service to the public.
- L₃: Loss of cultural heritage.
- L₄: Loss of economic value (structure and its content, service and loss of activity).

Types of loss which may be associated with a telecommunication network are:

- L'₂: Loss of service.
- L'₄: Loss of economic value.

NOTE 1 – Loss of human life associated with a telecommunication network is not considered because telecommunication personnel are requested not to work on telecommunication lines during thunderstorm activity.

NOTE 2 – Loss of cultural heritage is not relevant to a telecommunication network.

NOTE 3 – The loss of economic value associated with a telecommunication network is not considered by this Recommendation.

6.2 Risk and risk components

6.2.1 Risk

The risk R' is the value of a probable average annual loss.

To evaluate risk, R' , the relevant risk components (partial risks depending on the source and type of damage) shall be defined and calculated.

The risk, R' , is the sum of the risk components.

The risk components, which cause the loss of service in a telecommunication network, are reported in Figure 3 and are defined in clauses 6.2.2 to 6.2.4.

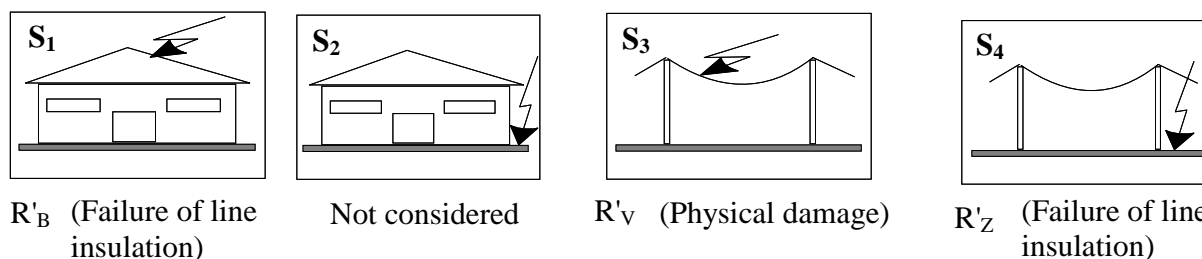

Figure 3 – Risk components causing the risk of loss of service in a telecommunication network related to each source of damage

6.2.2 Risk components due to flashes to the telecommunication network

Direct lightning flashes to a telecommunication network can cause the following risk component:

R'_V : Component related to physical damage of the telecommunication line due to mechanical and thermal effects of lightning current.

6.2.3 Risk component due to flashes near the telecommunication network

Lightning flashes near the telecommunication network can cause the following risk component:

R'_Z : Component related to failure of line insulation caused by overvoltages induced on telecommunication lines.

6.2.4 Risk components due to flashes to the structure to which the telecommunication network is connected

Direct lightning flashes to the structure to which the telecommunication network is connected can cause the following risk component:

R'_B : Component related to failure of line insulation caused by overvoltages or by thermal effects of lightning current flowing along the line.

6.3 Composition of risk components related to a telecommunication network

Risk of loss of service, R'_2 , in a telecommunication network is given by equation 1:

$$R'_2 = R'_V + R'_B + R'_Z \quad (1)$$

7 Risk management

7.1 Basic procedure

The following procedure shall be applied:

- identification of the telecommunication network to be protected and its characteristics;
- evaluation of risk R'_2 ;
- evaluation of need of protection, by the comparison of the risk R'_2 with the tolerable risk, R_T .

7.2 Tolerable risk R_T

It is the responsibility of the authority having jurisdiction to identify the value of tolerable risk.

A representative value of tolerable risk, R_T , against the loss of service along the telecommunication network due to lightning is given in Table 1.

Table 1 – Typical values of tolerable risk R_T

| Types of loss | $R_T(y^{-1})$ |
|-------------------------------|---------------|
| Loss of service to the public | 10^{-3} |

7.3 Specific procedure to evaluate the need for protection

For risk R'_2 the following steps shall be taken:

- identification of the telecommunication network to be protected and its characteristics;
- identification of the tolerable risk R_T ;
- calculation of the risk components R'_V and R'_B using [ITU-T K.47];
- comparison of the risk $R_d = R'_V + R'_B$ with the tolerable value R_T ;

- if $R_d > R_T$, protection measures against direct flashes shall be selected according to [ITU-T K.47];
- calculation of the risk component R'_Z using [ITU-T K.46];
- if $R'_Z > (R_T - R_d)$, protection measures against flashes near the telecommunication line shall be selected according to [ITU-T K.46];
- if $R'_Z < (R_T - R_d)$, protection is not necessary or protection is achieved.

Figure 4 shows the flow chart to evaluate the protection needs and for selecting the protection measures of telecommunication lines.

7.4 Protection measures

Protection measures are directed to reduce the risk according to the type of damage.

Protection measures shall be considered effective only if they conform to the requirements of [ITU-T K.47] and [ITU-T K.46].

7.5 Selection of protection measures

The selection of the most suitable protection measures shall be made by the protection designer according to the share of each risk component in the total risk and according to the technical and economic aspects of the different protection measures.

Critical parameters shall be identified to determine the more efficient measure to reduce the risk R'_2 .

For each type of loss, there is a number of protection measures which, individually or in combination, make the condition $R'_2 \leq R_T$. The solution to be adopted shall be selected with allowance for technical and economic aspects. A simplified procedure for selection of protective measures is given in the flow diagram of Figure 4. In any case, the installer or planner should identify the most critical risk components and reduce them, also taking into account economic aspects.

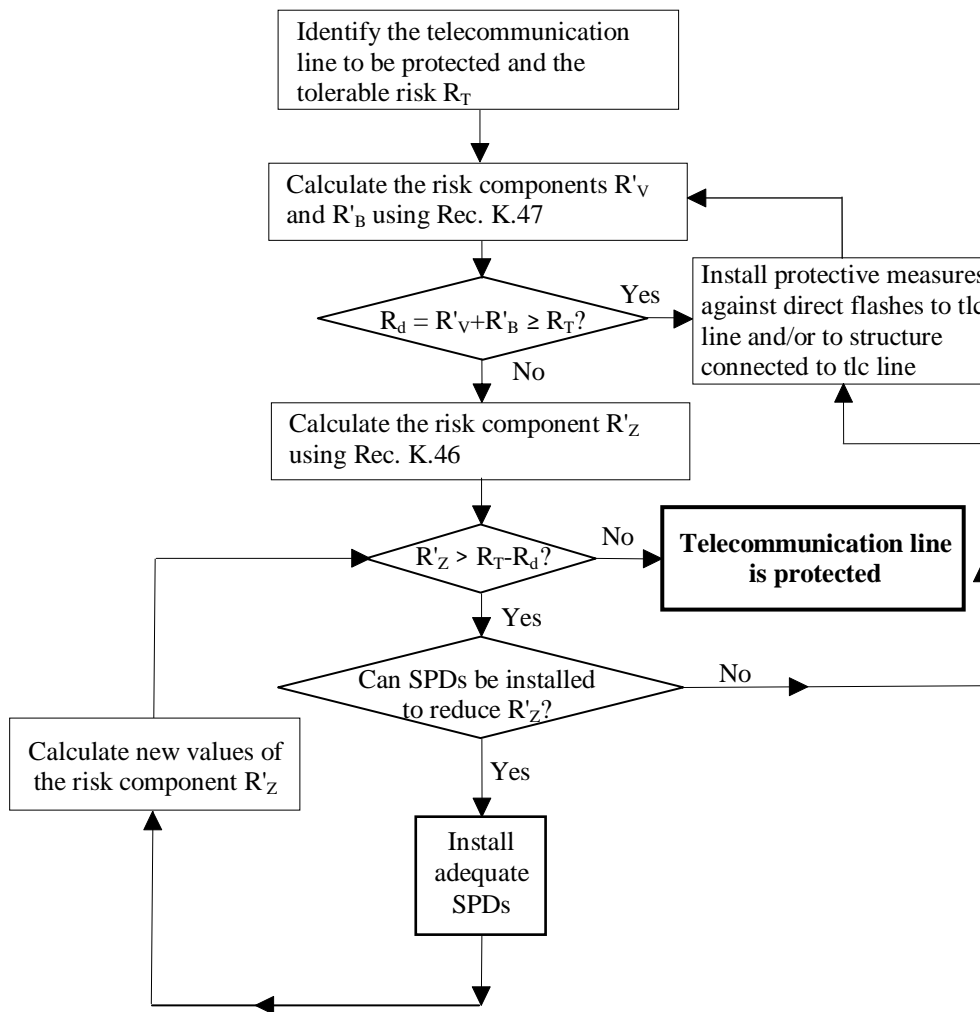

Figure 4 – Procedure for selecting protection measures in a telecommunication line

SERIES OF ITU-T RECOMMENDATIONS

| | |
|-----------------|---------------------------------------------------------------------------------------------|
| Series A | Organization of the work of ITU-T |
| Series D | General tariff principles |
| Series E | Overall network operation, telephone service, service operation and human factors |
| Series F | Non-telephone telecommunication services |
| Series G | Transmission systems and media, digital systems and networks |
| Series H | Audiovisual and multimedia systems |
| Series I | Integrated services digital network |
| Series J | Cable networks and transmission of television, sound programme and other multimedia signals |
| Series K | Protection against interference |
| Series L | Construction, installation and protection of cables and other elements of outside plant |
| Series M | Telecommunication management, including TMN and network maintenance |
| Series N | Maintenance: international sound programme and television transmission circuits |
| Series O | Specifications of measuring equipment |
| Series P | Telephone transmission quality, telephone installations, local line networks |
| Series Q | Switching and signalling |
| Series R | Telegraph transmission |
| Series S | Telegraph services terminal equipment |
| Series T | Terminals for telematic services |
| Series U | Telegraph switching |
| Series V | Data communication over the telephone network |
| Series X | Data networks, open system communications and security |
| Series Y | Global information infrastructure, Internet protocol aspects and next-generation networks |
| Series Z | Languages and general software aspects for telecommunication systems |