

ITU-T

TELECOMMUNICATION
STANDARDIZATION SECTOR
OF ITU

L.109

(11/2018)

SERIES L: ENVIRONMENT AND ICTS, CLIMATE
CHANGE, E-WASTE, ENERGY EFFICIENCY;
CONSTRUCTION, INSTALLATION AND PROTECTION
OF CABLES AND OTHER ELEMENTS OF OUTSIDE
PLANT

Optical fibre cables – Cable structure and characteristics

Construction of optical/metallic hybrid cables

Recommendation ITU-T L.109

ITU-T L-SERIES RECOMMENDATIONS

**ENVIRONMENT AND ICTS, CLIMATE CHANGE, E-WASTE, ENERGY EFFICIENCY; CONSTRUCTION,
INSTALLATION AND PROTECTION OF CABLES AND OTHER ELEMENTS OF OUTSIDE PLANT**

OPTICAL FIBRE CABLES	
Cable structure and characteristics	L.100–L.124
Cable evaluation	L.125–L.149
Guidance and installation technique	L.150–L.199
OPTICAL INFRASTRUCTURES	
Infrastructure including node elements (except cables)	L.200–L.249
General aspects and network design	L.250–L.299
MAINTENANCE AND OPERATION	
Optical fibre cable maintenance	L.300–L.329
Infrastructure maintenance	L.330–L.349
Operation support and infrastructure management	L.350–L.379
Disaster management	L.380–L.399
PASSIVE OPTICAL DEVICES	L.400–L.429
MARINIZED TERRESTRIAL CABLES	L.430–L.449

For further details, please refer to the list of ITU-T Recommendations.

Recommendation ITU-T L.109

Construction of optical/metallic hybrid cables

Summary

Recommendation ITU-T L.109 describes cable construction and provides guidance for the use of optical/metallic hybrid cable, which contains both optical fibres and metallic wires for telecommunication and/or power feeding. Technical requirements may differ according to the installation environment. Environmental issues and test methods for cable characteristics are described in other L-series Recommendations.

History

Edition	Recommendation	Approval	Study Group	Unique ID*
1.0	ITU-T L.109/L.60	2004-09-06	6	11.1002/1000/7394
2.0	ITU-T L.109	2018-11-29	15	11.1002/1000/13785

Keywords

Composite cables, DAS cables, FTTH cables, hybrid cable, optical/metallic cable

* To access the Recommendation, type the URL <http://handle.itu.int/> in the address field of your web browser, followed by the Recommendation's unique ID. For example, <http://handle.itu.int/11.1002/1000/11830-en>.

FOREWORD

The International Telecommunication Union (ITU) is the United Nations specialized agency in the field of telecommunications, information and communication technologies (ICTs). The ITU Telecommunication Standardization Sector (ITU-T) is a permanent organ of ITU. ITU-T is responsible for studying technical, operating and tariff questions and issuing Recommendations on them with a view to standardizing telecommunications on a worldwide basis.

The World Telecommunication Standardization Assembly (WTSA), which meets every four years, establishes the topics for study by the ITU-T study groups which, in turn, produce Recommendations on these topics.

The approval of ITU-T Recommendations is covered by the procedure laid down in WTSA Resolution 1.

In some areas of information technology which fall within ITU-T's purview, the necessary standards are prepared on a collaborative basis with ISO and IEC.

NOTE

In this Recommendation, the expression "Administration" is used for conciseness to indicate both a telecommunication administration and a recognized operating agency.

Compliance with this Recommendation is voluntary. However, the Recommendation may contain certain mandatory provisions (to ensure, e.g., interoperability or applicability) and compliance with the Recommendation is achieved when all of these mandatory provisions are met. The words "shall" or some other obligatory language such as "must" and the negative equivalents are used to express requirements. The use of such words does not suggest that compliance with the Recommendation is required of any party.

INTELLECTUAL PROPERTY RIGHTS

ITU draws attention to the possibility that the practice or implementation of this Recommendation may involve the use of a claimed Intellectual Property Right. ITU takes no position concerning the evidence, validity or applicability of claimed Intellectual Property Rights, whether asserted by ITU members or others outside of the Recommendation development process.

As of the date of approval of this Recommendation, ITU had not received notice of intellectual property, protected by patents, which may be required to implement this Recommendation. However, implementers are cautioned that this may not represent the latest information and are therefore strongly urged to consult the TSB patent database at <http://www.itu.int/ITU-T/ipr/>.

© ITU 2019

All rights reserved. No part of this publication may be reproduced, by any means whatsoever, without the prior written permission of ITU.

Table of Contents

	Page
1	Scope..... 1
2	References..... 1
3	Definitions 3
3.1	Terms defined elsewhere 3
3.2	Terms defined in this Recommendation..... 3
4	Abbreviations and acronyms 3
5	Conventions 3
6	Optical/metallic hybrid cable construction..... 3
6.1	Characteristics of each medium..... 4
6.2	Cable element 5
6.3	Mechanical characteristics..... 8
6.4	Environmental conditions..... 8
6.5	Fire safety 8
6.6	Electromagnetic compatibility..... 8
7	Test methods..... 8
7.1	Mechanical test methods 8
7.2	Environmental test methods 8
7.3	Cable element test methods 8
7.4	Electrical characteristic test methods 9
7.5	Transmission characteristic test methods 9
7.6	Electromagnetic compatibility..... 9
Appendix I – Chinese experience 10	
I.1	Introduction 10
I.2	Cable structure..... 10
I.3	Requirements..... 11
Appendix II – Chinese experience on hybrid cable for mobile communications in an access network..... 14	
II.1	Introduction 14
II.2	Background to the distributed base station..... 14
II.3	The integrated solution of distributed base station via DC centralized remote power supply 16
II.4	Conclusion..... 20
Appendix III – French/Polish experience 21	
III.1	Introduction 21
III.2	Cable design 21
Appendix IV – Swiss experience 23	
IV.1	Introduction 23
IV.2	Cable design 23

	Page
IV.3 Application	23
IV.4 Conclusion.....	24
Bibliography.....	25

Recommendation ITU-T L.109

Construction of optical/metallic hybrid cables

1 Scope

This Recommendation describe cables containing both optical fibres and metallic wires and covers the following aspects.

- Optical/metallic hybrid cables for communications systems.
- Construction of optical/metallic hybrid cables. The optical fibre dimensional and transmission characteristics, together with their test methods, should comply with [ITU-T G.652], [ITU-T G.653], [ITU-T G.654], [ITU-T G.655], [ITU-T G.656], [ITU-T G.657] and [IEC 60793-2-10]. Dimensional and transmission characteristics of metallic wires and coaxial units for telecommunication, together with their test methods, should comply with [ITU-T TR-OFCS];
- Cables designed for outdoor, indoor or indoor-outdoor use: fibre-to-the-antenna (FTTA) or distributed antenna systems (DAS) cables are examples of such hybrid cables.
- Cables for limited powering applications found in communications systems.
- A recommendation that an optical/metallic hybrid cable should be provided with cable-end sealing and protection during cable delivery and storage, as is usual for metallic or optical cables. If splicing components have been factory installed, they should be adequately protected.
- A recommendation that pulling devices can be fitted to the end of the cable if required.

2 References

The following ITU-T Recommendations and other references contain provisions which, through reference in this text, constitute provisions of this Recommendation. At the time of publication, the editions indicated were valid. All Recommendations and other references are subject to revision; users of this Recommendation are therefore encouraged to investigate the possibility of applying the most recent edition of the Recommendations and other references listed below. A list of the currently valid ITU-T Recommendations is regularly published. The reference to a document within this Recommendation does not give it, as a stand-alone document, the status of a Recommendation.

- [ITU-T G.650.1] Recommendation ITU-T G.650.1 (2018), *Definitions and test methods for linear, deterministic attributes of single-mode fibre and cable.*
- [ITU-T G.650.2] Recommendation ITU-T G.650.2 (2015), *Definitions and test methods for statistical and non-linear related attributes of single-mode fibre and cable.*
- [ITU-T G.652] Recommendation ITU-T G.652 (2016), *Characteristics of a single-mode optical fibre and cable.*
- [ITU-T G.653] Recommendation ITU-T G.653 (2010), *Characteristics of a dispersion-shifted single-mode optical fibre and cable.*
- [ITU-T G.654] Recommendation ITU-T G.654 (2016), *Characteristics of a cut-off shifted single-mode optical fibre and cable.*
- [ITU-T G.655] Recommendation ITU-T G.655 (2009), *Characteristics of a non-zero dispersion-shifted single-mode optical fibre and cable.*
- [ITU-T G.656] Recommendation ITU-T G.656 (2010), *Characteristics of a fibre and cable with non-zero dispersion for wideband optical transport.*

- [ITU-T G.657] Recommendation ITU-T G.657 (2016), *Characteristics of a bending-loss insensitive single-mode optical fibre and cable.*
- [ITU-T L.100] Recommendation ITU-T L.100/L.10 (2015), *Optical fibre cables for duct and tunnel application.*
- [ITU-T L.101] Recommendation ITU-T L.101/L.43 (2015), *Optical fibre cables for buried application.*
- [ITU-T L.102] Recommendation ITU-T L.102/L.26 (2015), *Optical fibre cables for aerial application.*
- [ITU-T L.103] Recommendation ITU-T L.103/L.59 (2016), *Optical fibre cables for indoor applications.*
- [IEC 60227-1] IEC 60227-1:2007, *Polyvinyl chloride insulated cables of rated voltages up to and including 450/750 V – Part 1: General requirements.*
- [IEC 60228] IEC 60228:2004, *Conductors of insulated cables.*
- [IEC 60502-1] IEC 60502-1:2009, *Power cables with extruded insulation and their accessories for rated voltages from 1 kV ($U_m = 1,2$ kV) up to 30 kV ($U_m = 36$ kV) – Part 1: Cables for rated voltages of 1 kV ($U_m = 1,2$ kV) and 3 kV ($U_m = 3,6$ kV).*
- [IEC 60793-2-10] IEC 60793-2-10:2017, *Optical fibres – Part 2-10: Product specifications – Sectional specification for category A1 multimode fibres.*
- [IEC 60794-1-21] IEC 60794-1-21:2015, *Optical fibre cables – Part 1-21: Generic specification – Basic optical cable test procedures – Mechanical test methods.*
- [IEC 60794-1-22] IEC 60794-1-22:2017, *Optical fibre cables – Part 1-22: Generic specification – Basic optical cable test procedures – Environmental test methods.*
- [IEC 60794-1-23] IEC 60794-1-23 Ed.1 (2012), *Optical fibre cables – Part 1-23: Generic specification – Basic optical cable test procedures – Cable elements Test Methods.*
- [IEC 60794-2] IEC 60794-2:2017, *Optical fibre cables – Part 2: Indoor cables – Sectional specification.*
- [IEC 60794-3] IEC 60794-3:2014, *Optical fibre cables – Part 3: Outdoor cables – Sectional specification.*
- [IEC 61156-1] IEC 61156-1:2009, *Multicore and symmetrical pair/quad cables for digital communications – Part 1: Generic specification.*
- [IEC 61196-1-10x] IEC 61196-1-10x-series, *Coaxial communication cables – Parts 1-100 to 1-109: Electrical test methods series.*
- [IEC 61156-2-1] IEC 61156-2-1:2010, *Multicore and symmetrical pair/quad cables for digital communications – Part 2-1: Horizontal floor wiring – Blank detail specification.*
- [IEC 62807-1] IEC 62807-1:2017, *Hybrid telecommunication cables – Part 1: Generic specification.*
- [IEC TR 62222] IEC TR 62222:2012, *Fire performance of communication cables installed in buildings.*

3 Definitions

3.1 Terms defined elsewhere

For the purposes of this Recommendation, the definitions given in [ITU-T G.650.1], [ITU-T G.650.2], and [ITU-T L.102] apply.

3.2 Terms defined in this Recommendation

None.

4 Abbreviations and acronyms

This Recommendation uses the following abbreviations and acronyms:

AC	Alternating Current
APL	Aluminium Polyethylene Laminate
AWG	American Wire Gauge
BBU	Baseband Unit
CSM	Central Strength Member
DAS	Distributed Antenna Systems
DBS	Distributed Base Stations
DC	Direct Current
ELFEXT	Equal Level of Far-End crosstalk
FAN	Fixed Access Network
FEXT	Far-End crosstalk
FRP	Fibre-Reinforced Plastic
FTTA	Fibre To The Antenna
FTTH	Fibre To The Home
NEXT	Near-End crosstalk
PE	Polyethylene
PSNEXT	Power Sum Of Near-end crosstalk
PVC	Polyvinyl Chloride
RAN	Radio Access Network
RRU	Remote Radio Unit
SMF	Single Mode Fibre
TPE-HF	Thermoplastic Elastomer-Halogen Free

5 Conventions

None.

6 Optical/metallic hybrid cable construction

This Recommendation deals with three types of optical/metallic hybrid cables as shown in Table 1.

Table 1 – Contents of each cable type

Cable type	Optical fibres	Metallic wires for telecommunication	Metallic wires for power feeding
Type I	Contained	Contained	No
Type II	Contained	No	Contained
Type III	Contained	Contained	Contained

Type I can be used for optical transmission and electric transmission carrying analogue or digital signals. Type II can be used for optical transmission and power feeding. Type III can be used for optical transmission, electric transmission carrying analogue or digital signals and power feeding.

There are several methods to contain those media in a cable. One is to strand each medium fabricated cylindrically (with or without other materials) around a central member. A second is to arrange all media in a round way (without a central member) and put a round sheath over it. A third is to insert media into slots of a slotted core as described in clause 6.2.7. Alternatively, flat or oval configurations meeting this intent may be used.

6.1 Characteristics of each medium

6.1.1 Optical fibre

Optical fibres described in [ITU-T G.652], [ITU-T G.653], [ITU-T G.654], [ITU-T G.655], [ITU-T G.656], [ITU-T G.657] and [IEC 60793-2-10] should be used, depending on circumstances and technical requirements.

Optical fibre elements described in [IEC 60794-2] and [IEC 60794-3] should be used, depending on circumstances and technical requirements.

6.1.2 Metallic wires for telecommunication

6.1.2.1 Symmetrical metallic pair

The electrical and transmission characteristics of a symmetrical pair or pairs for communication should comply with those agreed between the manufacturer and user. The following items should be agreed:

- maximum conductor direct current resistance;
- maximum conductor direct current resistance unbalance of the pair;
- mutual capacitance;
- capacitance unbalance;
- attenuation (insertion loss);
- near-end crosstalk (NEXT);
- power sum of near-end crosstalk (PSNEXT);
- far-end crosstalk (FEXT);
- equal level of far-end crosstalk (ELFEXT);
- impedance;
- return loss;
- insulation resistance;
- any other parameter to be agreed between the manufacturer and user.

The mechanical and the environmental characteristics should comply with [IEC 61156-2-1] unless there is a different agreement between the manufacturer and user.

6.1.2.2 Coaxial conductors

The electrical and transmission characteristics of coaxial conductors for communication should comply with those agreed between the manufacturer and user. The following items should be agreed:

- characteristic impedance;
- conductor resistance;
- attenuation;
- velocity ratio;
- return loss;
- insulation resistance;
- withstand voltage of dielectric;
- any other parameter to be agreed between the manufacturer and user.

The mechanical and the environmental characteristics should be agreed between the manufacturer and user.

6.1.3 Power-feeding wires

The conductor characteristics of the copper wire should comply with [IEC 60228], unless there is a different agreement between the manufacturer and user. The insulation characteristic of the copper wire should comply with [IEC 60502-1] or [IEC 60227-1] criterion requirements, unless there is a different agreement between the manufacturer and user.

Coaxial conductor design can be used where low impedance is required for pulsed power supply applications.

The cross-section of the metallic wire should be designed according to the transmission voltage, transmission distance and the power consumption. Under extreme operating conditions, the heat generated by conductors should not make the cable temperature exceed the maximum allowed temperature in detailed specifications of the cable element materials.

Conductors and insulation materials for power-feeding wires should be specified in detail.

6.2 Cable element

The make-up of the cable core, in particular the number of fibres, their method of protection and identification, the location of strength members and metallic wires or pairs, if required, should be clearly specified. Designs other than those described in clauses 6.2.1 to 6.2.16 may be used, provided that they comply with the aims of this Recommendation.

6.2.1 Tight secondary coating or buffer

If a tight secondary coating is required, it should consist of one or more layers of polymeric material. The coating should be easily removable for splicing. For tight buffers, the buffer and fibre primary coating should be removable in one operation over a length depending on customer requirements. The nominal overall diameter of the tight secondary coating is typically between 800 µm and 900 µm.

In FTFA applications, tight buffered fibres can be used. Spiral stainless steel tubes can be used to protect and gather those buffered fibres.

6.2.2 Loose tube

A loose tube construction or a loose tube cable is frequently used to protect and gather optical fibres or fibre ribbons. Water blocking material may be contained in the tube if required for the application.

6.2.3 Micromodule

A micromodule is a thin-walled tubing unit. These flexible modules have bending radii similar to the unbundled fibre, and are easy to strip without a tool for easy splice preparation and mid-span access. They have no shape memory and may be used directly in an enclosure up to the splicing tray. A water-blocking material may be contained in the micro-module, if required. See Figure 1.

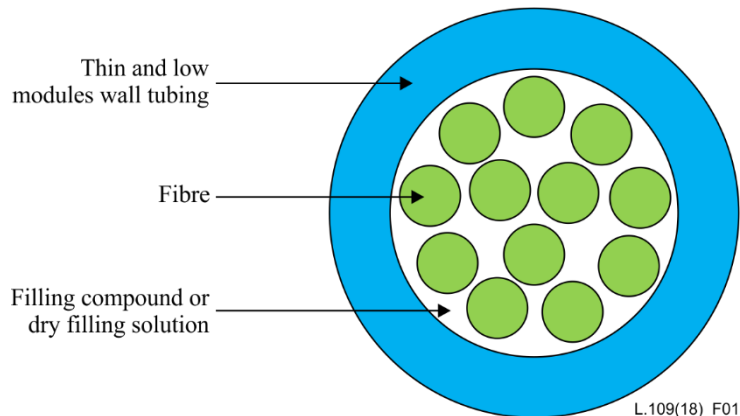

Figure 1 – Example of primary coated fibres protected by micro-module

6.2.4 Symmetrical pair unit

A symmetrical pair unit contains stranded metallic pairs. It is fabricated cylindrically with or without additional suitable material. Its diameter is similar to that of a loose tube. When a screen is required over the symmetrical pair, it may consist of the following:

- a) an aluminium tape laminated to a plastic tape;
- b) an aluminium tape laminated to a plastic tape and a metal-coated or plain drain copper wire which the metal tape is in contact with;
- c) metallic braid;
- d) an aluminium tape laminated to a plastic tape and a metallic braid.

6.2.5 Coaxial unit

A coaxial unit contains a pair of coaxial inner and outer conductors or two pairs of coaxial conductors which can form a differential line pair. The coaxial unit is fabricated cylindrically with or without additional suitable materials in order to have a diameter similar to that of a loose tube.

6.2.6 Power-feeding wire unit

A power-feeding wire unit contains power-feeding wire(s) and is fabricated cylindrically with or without suitable material.

6.2.7 Slotted core

In order to avoid direct pressure on optical fibres from the outside of the cable, optical fibres or ribbon fibres may be located in slots. Usually, slots are provided in a helical or SZ configuration stranded around a cylindrical rod. The slotted core usually contains a strength member (metallic or non-metallic). The strength member should adhere tightly to the slotted core in order to obtain temperature stability and avoid separation when a pulling force is applied during installation.

6.2.8 Strength member

The cable should be designed with strength member(s) suitable to meet installation and service conditions so that the fibres are not subjected to strain levels in excess of those agreed between the manufacturer and user. The strength member(s) may be either metallic or non-metallic.

In FTTA applications, it is recommended that non-metallic strength members be used, e.g., aramid yarns, glass fibre-reinforced plastic (FRP) rods or other suitable fibre reinforced materials. For stranded core structures, FRP rods should be laid in the centre of the core. Other types of strength members can be placed in suitable positions according to the hybrid cable structure.

6.2.9 Filler (optional)

If necessary, fillers can be used with a similar outer diameter to the loose tubes. They can be in the form of a circular plastic rod with smooth surface.

6.2.10 Water blocking material (optional)

Filling a cable with water-blocking material or wrapping the cable core with layers of water swellable material are two means of protecting fibres from water ingress. A water-blocking element (filling compound, tapes or yarns, water swelling powder or combination of materials) may be used. Any materials used should not be harmful to personnel. The materials in the cable should be compatible with each other and, in particular, should not adversely affect fibre characteristics. These materials should not hinder splicing or connection operations.

6.2.11 Ripcord (optional)

If required, a ripcord can be used. It should be non-hygroscopic, non-oil absorbing and have enough strength to strip the cable sheath.

6.2.12 Inner sheath (optional)

If required, an inner sheath over the cable core and beneath the outer sheath with optional armouring layer and shielding layer can be used. In indoor and indoor-outdoor applications, the material of the inner sheath can be fire retardant for fire safety reasons depending on local regulations.

6.2.13 Screen of the cable core (optional)

When electromagnetic compatibility or lightning proofing is required, a screen can be added over the cable core. In FTTA applications, the screen is able to reduce the current level induced by lightning and minimize the electromagnetic noise induced by current. The screen may consist of a single or double metal tape layers (or foil), single or double metal braid layers or a combined structure of metal braid and metal tape (or foil). A drain wire in contact with the metal shield layers can be used. A metallic sheath or continuous metal armouring layer can also act as the screen of the cable core.

6.2.14 Armouring layer (optional)

In particular applications where better mechanical performance is required for hybrid cable, an armouring layer can be added over the cable core or directly over the optical fibre unit. Armouring material can be metallic or non-metallic.

6.2.15 Outer sheath

The cable core should be covered with a sheath or sheaths suitable for the environmental and mechanical conditions associated with storage, installation and operation. The sheath may be of a composite construction and may include strength members.

Sheath considerations for optical fibre cables are generally the same as for metallic conductor cables. Consideration should also be given to the amount of hydrogen generated from a metallic moisture barrier. The minimum acceptable thickness of the sheath should be stated, together with any maximum and minimum allowable overall cable diameter.

Selection of sheath material is one of the important issues to be considered in order, for example, to ensure stability under the environmental conditions of installation and to satisfy fire safety requirements. Polyethylene (PE), polyvinyl chloride (PVC) and thermoplastic polyurethane are

typically used as cable sheath materials for outdoor cables. Fire-retardant sheath materials may vary for indoor or indoor-outdoor cables for fire safety reasons depending on local regulations.

The electrical tracking resistance of sheath materials may be an issue for type II and III cables. In FTTA and other outdoor applications, the outer sheath of hybrid cable should be able to resist ultraviolet rays and heat shock. Ultraviolet shielding is commonly provided by a UV-stabilized weather resistant material containing a minimum of 2.0% by mass of well-dispersed carbon black.

6.2.16 Cable and cable elements marking

Hybrid cable and cable units containing optical fibres and power-feeding units should be clearly coded in order to indicate that dangerous current flows through them and distinguish one type of unit from another.

6.3 Mechanical characteristics

Unless there is a different agreement between the manufacturer and user, an optical/metallic hybrid cable should have the mechanical characteristics specified in [ITU-T L.100], [ITU-T L.101], [ITU-T L.102] or [ITU-T L.103] and [IEC 62807-1], depending on the installation environment.

6.4 Environmental conditions

Unless there is a different agreement between the manufacturer and user, an optical/metallic hybrid cable should meet the environmental conditions specified in [ITU-T L.100], [ITU-T L.101], [ITU-T L.102] or [ITU-T L.103] and [IEC 62807-1] depending on the installation environment.

6.5 Fire safety

Requirements for fire performance in different applications may differ in each country. Optical/metallic hybrid cables should meet fire safety regulations in each country or in accordance with each telecommunication carrier. [IEC TR 62222] should be considered if there are no fire safety specifications provided.

6.6 Electromagnetic compatibility

If required, electromagnetic compatibility requirements should be agreed between the manufacturer and user, depending on different applications, including transfer impedance and coupling attenuation of screens of metallic units and the overall screen of cable.

7 Test methods

Unless there is a different agreement between the manufacturer and user, an optical/metallic hybrid cable should be evaluated by the test methods specified in [ITU-T L.100], [ITU-T L.101], [ITU-T L.102] or [ITU-T L.103] and [IEC 62807-1] depending on the installation environment.

7.1 Mechanical test methods

Mechanical tests of hybrid cable should comply with [IEC 60794-1-21].

7.2 Environmental test methods

Environmental tests of hybrid cable should comply with [IEC 60794-1-22].

7.3 Cable element test methods

Cable element test methods should comply with [IEC 60794-1-23].

7.4 Electrical characteristic test methods

Electrical characteristics of hybrid cable should include voltage test, insulation resistance, conductor resistance of power-feeding wires and electrical characteristics of symmetrical metallic pairs listed in clause 6.1.2. Test methods of voltage test, insulation resistance and conductor resistance of power-feeding wires should comply with [IEC 60502-1] or [IEC 60227-1]. Test methods for electrical characteristics of symmetrical pairs should comply with [IEC 61156-1]. Test methods for electrical characteristics of coaxial units should comply with documents in the series [IEC 61196-1-10x].

7.5 Transmission characteristic test methods

Test methods for transmission characteristics of symmetrical pairs listed in clause 6.1.2 should comply with [IEC 61156-1]. Test methods for transmission characteristics of coaxial units should comply with documents in the series [IEC 61196-1-10x].

7.6 Electromagnetic compatibility

Test methods for transfer impedance and coupling attenuation should comply with [IEC 61156-1].

Appendix I

Chinese experience

(This appendix does not form an integral part of this Recommendation.)

I.1 Introduction

Optical and metal hybrid cables are developing quickly in the access network. The cable is used not only for optical signals, but also digital signals to be transmitted and for the power needed to feed active equipment. Wireless remote radio technology is becoming one of the most important technologies in fibre to the home (FTTH). A wireless remote radio system always contains a baseband unit (BBU) and a remote radio unit (RRU). Hybrid cables containing both optical and copper units have been adopted to connect BBU and RRU for several years, since they can transmit optical signals and power simultaneously with such advantages as low cost and easy installation.

I.2 Cable structure

This appendix presents three main types of optical fibre/stranded copper hybrid cables used in different access network application environments. Each type has been successfully installed in the access network in China.

Three main optical/metallic hybrid cables are shown in Figure I.1 to Figure I.3.

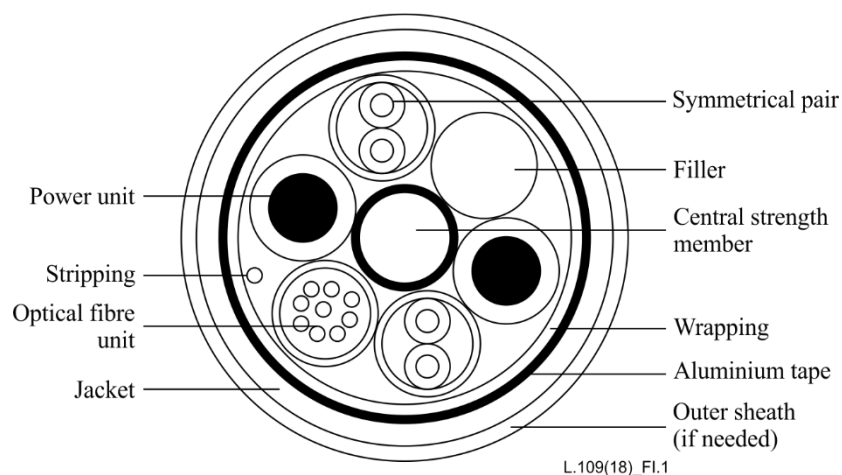

Figure I.1 – The typical optical/metallic hybrid cable structure (type III hybrid cable)

This hybrid cable type is:

- optical fibre/symmetrical pair units for optical/data signal transmission;
- optical fibre/stranded copper wire units for optical signal transmission and power feeding to active equipment;
- optical fibre/symmetrical pair/stranded copper wire hybrid cable for optical/data signal transmission and power feeding to active equipment.

The transmission distance of the optical fibre/stranded copper hybrid cables mentioned in the previous paragraph should meet customer needs; normally the distance covered is from 100 m to 3 000 m.

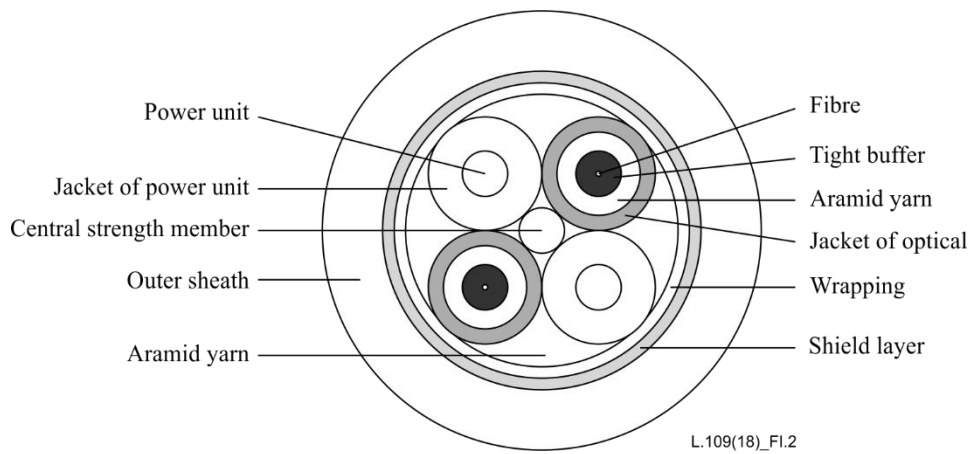

Figure I.2 – Example of hybrid optical cable with tight-buffer optical unit and power unit

This hybrid cable type is:

- optical fibre/stranded copper wire units for optical signal transmission and power feeding to active equipment;
- optical fibre buffered by a tight material to be easily connected or terminated conveniently.

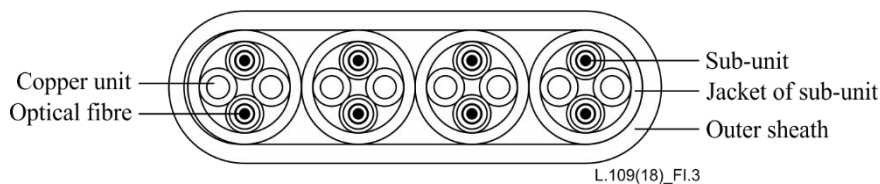

Figure I.3 – Example of hybrid optical cable with wireless remote radio unit

This hybrid cable type is:

- four sub-units composed of two single core optical fibre indoor cables and two copper wires;
- usually used for optical signal transmission and power feeding to active equipment in a wireless remote system.

I.3 Requirements

I.3.1 Optical fibre

The optical fibres should comply with [b-ITU-T G.651.1], [ITU-T G.652] and [ITU-T G.657] requirements. The number of optical fibres ranges from two to 24 cores or according to customer need.

I.3.2 Symmetrical pair

The symmetrical pair has 100 Ω resistance. The mechanical and environmental characteristics comply with those specified in [IEC 61156-2-1] and the electrical characteristics are shown in Tables I.1 to I.7. Symmetrical pair identification is shown in Table I.8.

Table I.1 – Electrical characteristics of 100 Ω symmetrical pair (20° C)

Item		Unit	Normative diameter of the conductor	
			0.5 mm	0.6 mm
Conductor direct current resistance, maximum		Ω/100 m	9.5	6.58
Conductor direct current resistance unbalance of the pair, maximum		%	2.5	
Working capacitance, maximum	5, 5e	nF/100 m	5.6	

Table I.2 – Attenuation of 100 Ω symmetrical pair (20° C)

Symmetrical pair type	Conductor diameter (mm)	Frequency f (MHz)	Attenuation (dB/100 m)
5, 5e	0.5	1-100	$1.967 \times \sqrt{f} + 0.023 \times f + \frac{0.050}{\sqrt{f}}$
5, 5e	0.6	1-100	$1.695 \times \sqrt{f} + 0.020 \times f + \frac{0.040}{\sqrt{f}}$

Table I.3 – Near-end crosstalk (NEXT) of 100 Ω symmetrical pair

Symmetrical pair type	Frequency f (MHz)	NEXT (dB/100 m)
5	1-100	$62.3 - 15 \times \lg f$
5e	1-100	$65.3 - 15 \times \lg f$

Table I.4 – Power sum of near-end crosstalk (PSNEXT) of 100 Ω symmetrical pair

Symmetrical pair type	Symmetrical pair unit	Frequency f (MHz)	PSNEXT (dB/100 m)
5	Over 4	1-100	$62.3 - 15 \times \lg f$
5e	4	1-100	$62.3 - 15 \times \lg f$

Table I.5 – Characteristic impedance of 100 Ω symmetrical pair

Frequency (MHz)	Characteristic impedance (Ω)	
	5	5e
$f \geq 1$	100 ± 15	100 ± 15

Table I.6– Minimum return loss (RL) of 100 Ω symmetrical pair

Type	Frequency f (MHz)				
	$1 \leq f \leq 10$	$10 < f \leq 16$	$16 < f \leq 20$	$20 < f \leq 100$	$100 < f \leq 250$
5	$17 + 3 \times \lg f$	20	20	$20 - 7 \times \lg(f/20)$	–
5e	$20 + 5 \times \lg f$	25	25	$25 - 7 \times \lg(f/20)$	–

Table I.7 – Minimum structure return loss (SRL) of 100 Ω symmetrical pair

Type	Frequency f (MHz)				
	$1 \leq f \leq 10$	$10 < f \leq 16$	$16 < f \leq 20$	$20 < f \leq 100$	$100 < f \leq 250$
5	23	23	23	$23 - 10 \times \lg(f/20)$	–
5e	28	28	28	$28 - 10 \times \lg(f/20)$	–

Table I.8 – Pair identification

Pair 1	Blue/white
Pair 2	Orange/white
Pair 3	Green/white
Pair 4	Brown/white

I.3.3 Power unit

The cross-section of a feeder conductor should be designed reasonably on the supply voltage, transmission distance and power of the remote device. The inside temperature of the cable should not significantly increase during normal operating conditions.

The feeder conductor should use soft single conductor non-sheathed cable. If needed, hard single conductor non-sheathed cable can be used. Its performance should comply with the relevant product standards.

The single conductor is usually an entire body within the cable length. It allows up to two joints in the cable length. The joint is connected by hot or cold welding. The tensile strength of the joint should not be less than 85% of the non-joint single entire body. Appropriate methods and materials should be adopted to repair joint insulation to meet standard requirements for electrical performance.

Appendix II

Chinese experience on hybrid cable for mobile communications in an access network

(This appendix does not form an integral part of this Recommendation.)

II.1 Introduction

An integrated solution for a distributed base station via direct current (DC) remote power supply is proposed in this appendix. Furthermore, the determination of conductor cross-sectional area in the hybrid cable as well as the hybrid cable sample used in this case is also presented.

II.2 Background to the distributed base station

With the development of mobile communication technology, distributed base stations (DBSs) is widely used in the 3G/4G mobile communication network in China.

II.2.1 Traditional centralized base station

The traditional centralized base station locates the BBU and radio unit in a cabinet. This base station has the advantage of large capacity, but also the disadvantages of inconvenience in network expansion, deployment and construction, as well as high cost and large loss. The specific structures can be divided into indoor and outdoor centralized base stations, which are illustrated in Figure II.1 and Figure II.2, respectively.

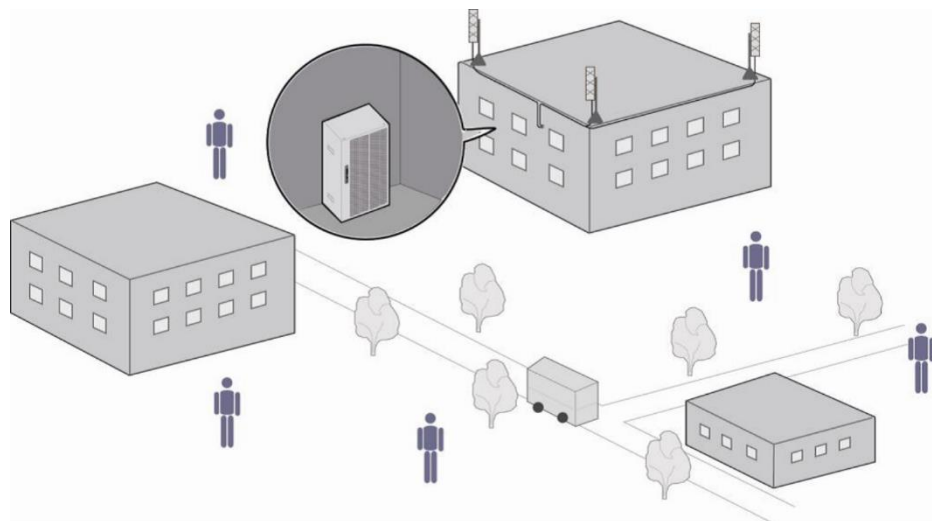

L.109(18)_FII.1

Figure II.1 – Indoor centralized base station

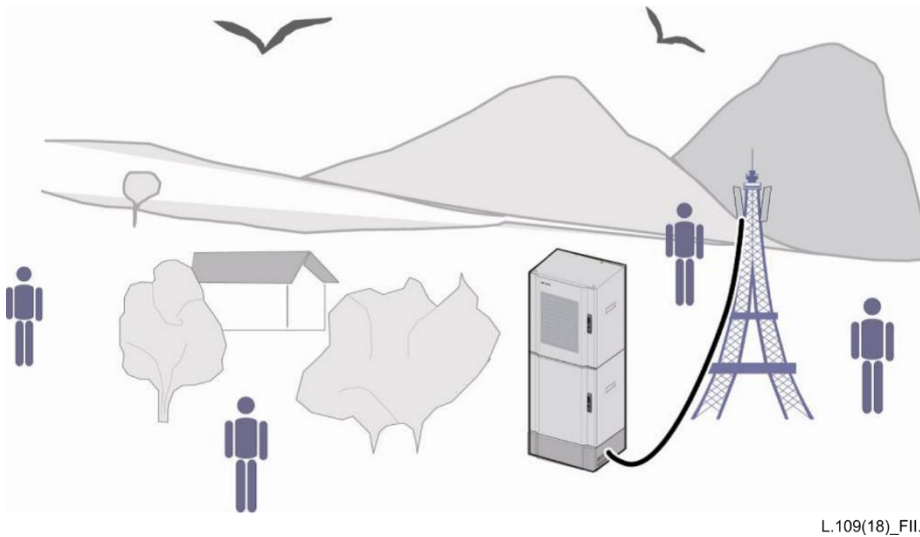

Figure II.2 – Outdoor centralized base station

II.2.2 First generation distributed base station

With the breakthrough of high integrated baseband processing technology, high-speed access technology and radio frequency remote technology, miniaturization and modularization of 3G base stations can be realized. The distributed base station based on radio frequency remote technology keeps the baseband part and RF part apart. The RRU is located near the antenna to handle wireless signals within base station coverage. The RRU processes and transfers the optical signal to the BBU via optical fibres. The advantages of separate modular design for the distributed base station include low cost, small size, deployment flexibility and convenience for network expansion, which is suitable for dense urban areas. A distributed base station is shown schematically in Figure II.3.

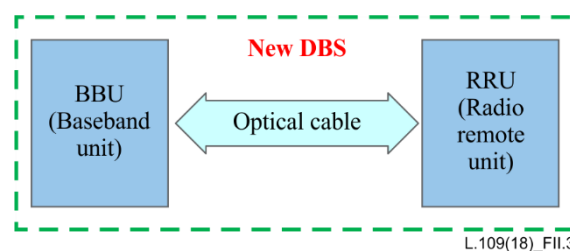

Figure II.3 – First generation distributed base station

II.2.3 Second generation distributed base station

The separate design for the BBU and RRU has many advantages, but also brings new challenges to the power supply for the RRU.

There are three solutions for RRU power supply for a distributed base station: DC remote power supply, independent AC power supply and independent power supply via solar energy. In this appendix, an integrated solution based on DC remote power supply, which is called a second generation distributed base station with centralized power supply, is proposed and presented.

The second generation distributed base station is suitable for communication network coverage area with a guard-free base station and room-free base station in order to reduce costs during operation and maintenance, as shown in Figure II.4.

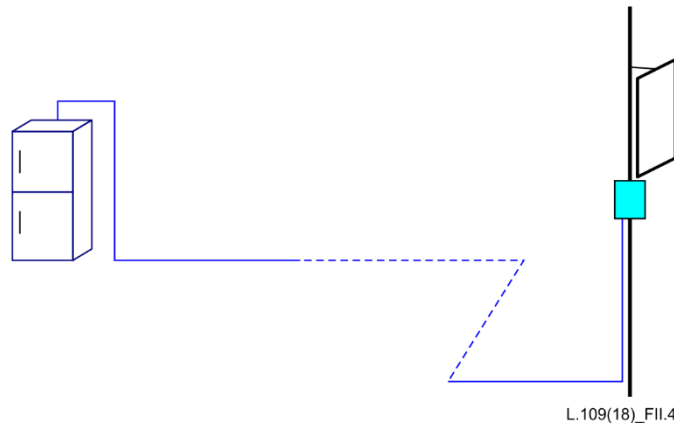

Figure II.4 – Second generation distributed base station

II.2.4 The topology of a distributed base station

With the large data flow in the 4G network, the frequency level of the base station increases and the coverage radius of the base station is reduced. The network topology between the BBU and RRU for the distributed base station becomes more complicated. There are several types of network topology from BBU to RRU, such as P2P, star, chain, ring and mixture structures.

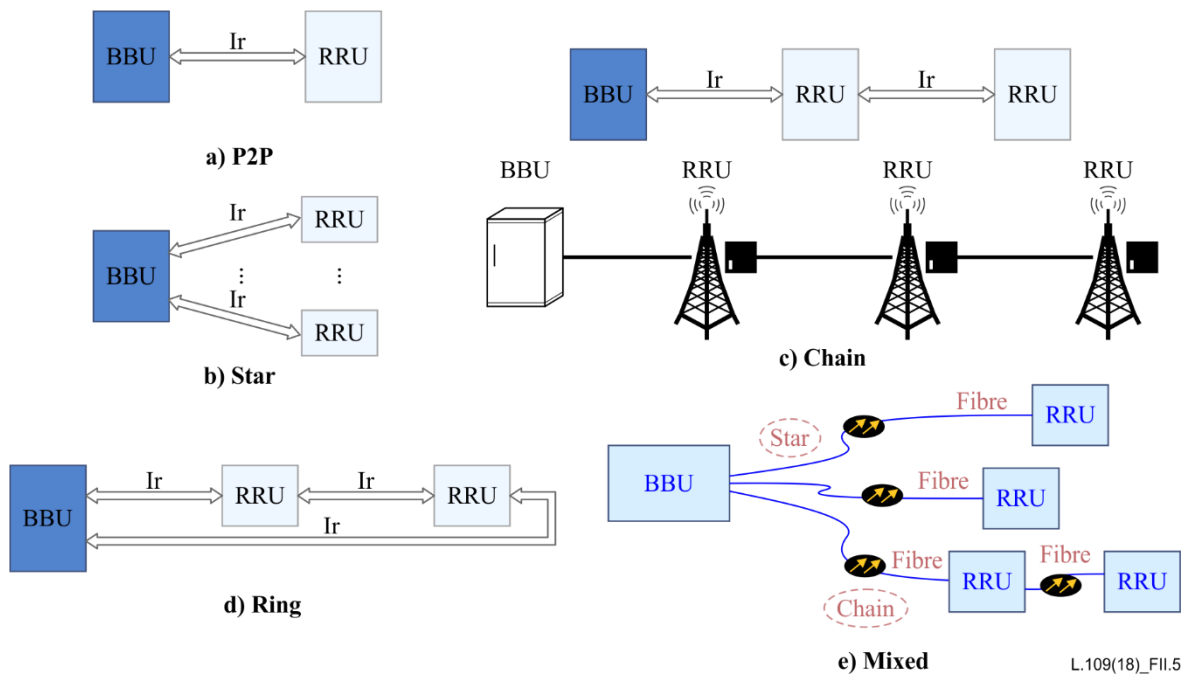

Figure II.5 – P2P, star, chain, ring, and mixture structures

II.3 The integrated solution of distributed base station via DC centralized remote power supply

II.3.1 DC remote power supply solution for DBS

The original "RRU DC remote power supply solution" has the advantages such as simple structure and high reliability. However, because the DC power supply voltage is low, the transmitted current value is relatively large, which results in high cost due to the large size of power conductors. At the same time, the longer the transmission distance is, the larger the voltage drop and the power loss will occur. Therefore, this contribution provides a smart integrated solution which includes a DC booster located near BBU to boost DC -48 V to 380 V or 350 V. Then the power module located near RRU

transforms 380 V or 350 V into –48 V for the power supply for RRU. The hybrid cable is used to connect BBU with RRU directly.

II.3.2 DC remote power supply unit of a distributed base station

The integrated solution of a DC remote power supply for DBS is shown schematically in Figure II.6.

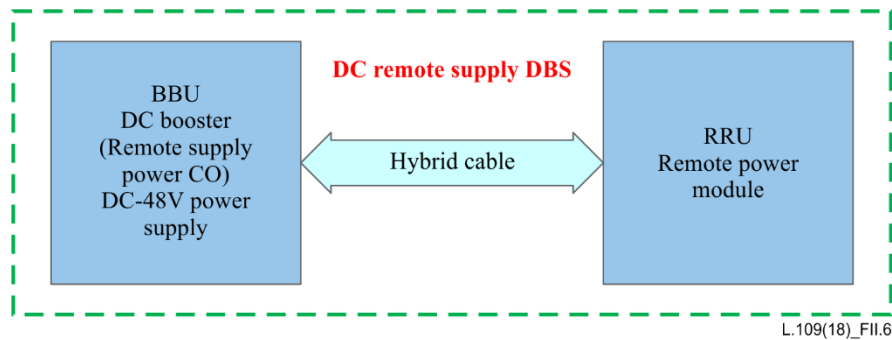

Figure II.6 – DC remote supply unit diagram of a distributed base station

II.3.3 Direct current remote power supply circuit diagram

The principle for DC remote power supply solution can be simplified as a circuit diagram, as shown in Figure II.7, and the voltage drop on the conductor in hybrid cable can be calculated, as shown in Equation (1), while the ring resistance of the conductor in hybrid cable can be calculated, as shown in Equation (2).

$$\Delta U = U_i - U_o = 2 \times L \times R_c = 2P \times R_c / U_o \quad (1)$$

$$R = R_c + R_c = 2 \times R_c = 2 \times (\rho \times \lambda_1 \times \lambda_2 \times l / A) \quad (2)$$

$$L = \lambda_3 U_i^2 / (4P * R) \quad (3)$$

where

- R denotes ring resistance
- U_i denotes input voltage after DC booster
- U_o denotes output voltage for RRU
- L denotes remote distance of DBS
- R_c denotes resistance of conductor
- ΔU denotes voltage drop on conductor
- ρ denotes resistivity ($\Omega \cdot \text{mm}^2 / \text{m}$)
- l denotes conductor length (m)
- A denotes nominal area of conductor (mm^2)
- P denotes rated power of RRU (W)
- λ_1 denotes stranding ratio, usually 1.0133
- λ_2 denotes safety margin, usually 1.03-1.15
- λ_3 denotes transfer efficiency for remote equipment power, usually 0.80-0.90

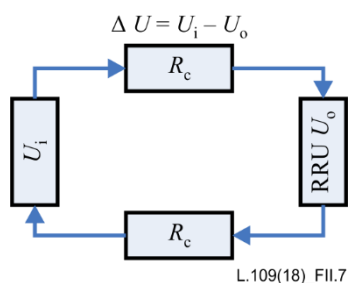

Figure II.7 – Direct current remote power supply circuit diagram

II.3.4 Copper conductor design

Based on Equation (2) and the resistivity of a copper conductor, the resistance parameters can be calculated, as shown in Table II.1.

Table II.1 – Relevant resistance parameters for a copper conductor

Conductor cross-sectional area (mm ²)	Length of cable (m)	Resistance of conductor R_c (Ω)	Ring resistance R (Ω)
1.5	1 000	13.3	26.6
2.5	1 000	7.98	15.96
4.0	1 000	4.95	9.90
6.0	1 000	3.30	6.60

The resistivity of a copper conductor is 0.01757.

Based on Equations (1), (2) and (3), the relationship matrix regarding remote distance, DC remote supply voltage, copper conductor cross-sectional area and rated RRU power can be obtained, as shown in Table II.2.

Table II.2 – Relationship matrix regarding remote distance, DC voltage, conductor cross-sectional area and rated remote radio unit power

Total power for remote radio unit (W)	Remote distance (km)							
	350 VDC				380 VDC			
	Nominal area for copper conductor				Nominal area for copper conductor			
	2 × 1.5	2 × 2.5	2 × 4.0	2 × 6.0	2 × 1.5	2 × 2.5	2 × 4.0	2 × 6.0
200	4.2	6.9	11.5 m	16.8	5.6	9.2	14.8	22.4
300	2.8	4.7	7.7	11.2	3.7	6.0	9.7	14.8
400	2.1	3.5	5.7	8.4	2.8	4.6	7.4	11.2
600	1.4	2.4	3.4	5.6	1.9	3.0	4.9	7.6
800	1.1	1.8	2.9	4.2	1.4	2.3	3.7	5.6
1 000	0.90	1.4	2.3	3.6	1.1	1.8	3.0	4.4
1 200	0.70	1.2	1.7	2.8	1.0	1.5	2.5	4.0

II.3.5 Aluminium conductor design

Based on Equation (2) and the resistivity of an aluminium conductor, the resistance parameters can be calculated, as shown in Table II.3.

Table II.3 – Relevant resistance parameters for an aluminium conductor

Conductor cross-sectional area (mm ²)	Length of cable (m)	Resistance of conductor R_C (Ω)	Ring resistance R (Ω)
6.0	1 000	4.61	9.22
8.0	1 000	3.83	7.66
10.0	1 000	3.08	6.16
16.0	1 000	1.91	3.82

The resistivity of an aluminium conductor is 0.02838.

Based on Equations (1), (2) and (3), the relationship matrix regarding remote distance, DC remote supply voltage, aluminium conductor cross-sectional area and rated RRU power can be obtained, as shown in Table II.4.

Table II.4 – Relationship matrix regarding remote distance, DC voltage, conductor cross-sectional area and rated remote radio unit power

Total power for remote radio unit (W)	Remote distance (km)							
	350 VDC				380 VDC			
	Nominal area for aluminium conductor				Nominal area for aluminium conductor			
	2 × 6.0	2 × 8.0	2 × 10.0	2 × 16.0	2 × 6.0	2 × 8.0	2 × 10.0	2 × 16.0
200	5.8	7.6	9.6	15.2	7.7	10.2	12.8	15.4
300	3.8	5.2	6.4	10.4	5.1	7.0	8.6	14.0
400	2.9	3.8	4.8	7.6	3.9	5.2	6.4	10.4
600	1.9	2.6	3.2	5.2	2.6	3.6	4.3	7.2
800	1.5	2.0	2.4	4.0	2.0	2.6	3.2	5.2
1000	1.2	1.6	1.9	3.2	1.5	2.0	2.6	4.0
1200	1.0m	1.4	1.6	2.8	1.3	1.8	2.2	3.6

II.3.6 Hybrid optical and electrical cable design

II.3.6.1 Design principles

The hybrid optical and electrical cable described here is a kind of such cable via a centralized DC power supply. The cable design includes conductor cross-sectional area, as illustrated in clauses II.3.4 and II.3.5 and fibre core design, which is affected by the topology between BBU and RRU.

For an outdoor distributed base station, a star type topology is generally adopted. The antenna of a base station for mobile communication usually has three sectors. Each of them connects an RRU independently. Every connection between the BBU and RRU usually occupies two single-mode optical fibre channels. Thus six fibres are required for a base station. Considering fibre backup, 12 fibres are sufficient for a base station. In some cases, such as towers with two base stations or when future upgrade is predicted, design of a hybrid optical and electrical cable with 24 fibres is required.

II.3.6.2 Design example

A kind of hybrid optical and electrical cable is designed, as shown in Figure II.8. Single mode fibres (SMFs) are contained in the loose tube filled with jelly. A steel wire is employed as the central strength member. Tubes and insulated copper conductors are stranded around the central strength

member. An aluminium polyethylene laminate (APL) tape is longitudinally wrapped around the cable core. Then, the cable core is extruded with a PE sheath.

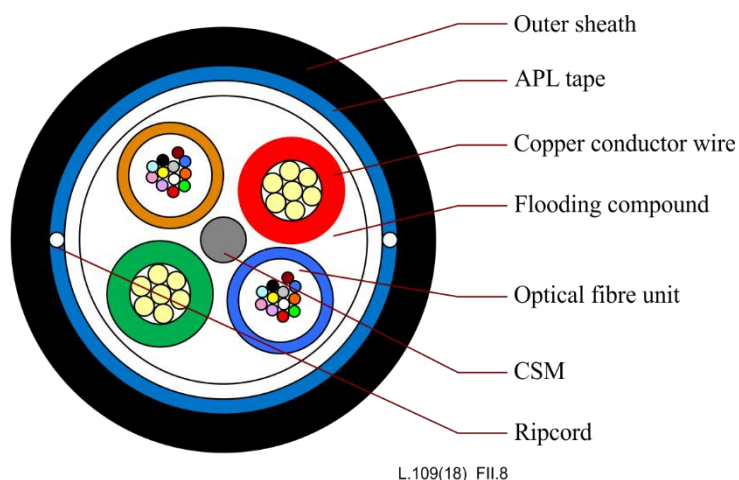

Figure II.8 – Hybrid cable cross-section for GDTA –24B1.3+2*4 mm²
CSM: central strength member

The hybrid cable design has the following advantages:

- small size, light weight, easy installation and low cost;
- combines optical fibre cable with power cable;
- good mechanical properties and electrical properties, as well as environmental performance;
- the cable design of "two copper wires and 24 optical fibres" is suitable for the flexible topology between BBU and RRU.

II.4 Conclusion

This appendix introduces an integrated solution for a distributed base station via DC remote power supply, including the design of conductor cross-sectional area in hybrid cable, as well as the design of optical cable core. The relationship matrix regarding remote distance, DC remote supply voltage, conductor cross-sectional area and rated RRU power is also given. It can ensure smart mobile communication by offering a stable power supply to the base station.

Appendix III

French/Polish experience

(This appendix does not form an integral part of this Recommendation.)

III.1 Introduction

The hybrid cable design in this appendix is an example of a typical cable construction that is used for a fixed access network (FAN) and a radio access network (RAN), e.g., for remote radio head (RRH) installations. In the hybrid cable, optical fibres provide data communication and copper conductors provide 400 VDC remote powering solutions. See Figure III.1.

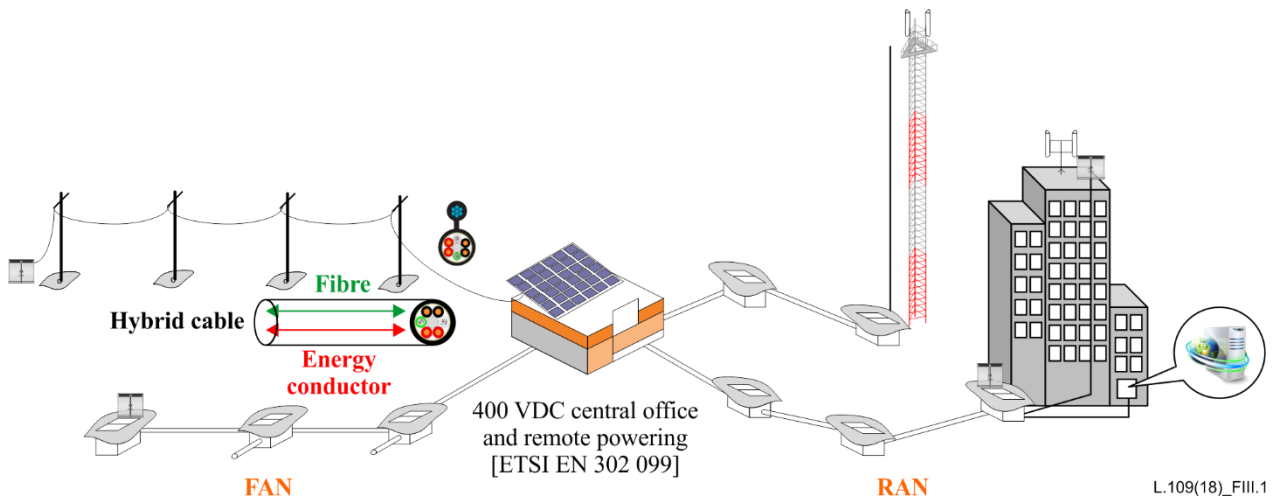

Figure III.1 – Example for remote radio head installation

III.2 Cable design

The cable is realized with one or several copper pairs of conductors with cross-sectional area 2.5 mm^2 or 4 mm^2 , 12 to 48 (modulo 12) single-mode fibres and rip cords.

For example, if total copper pairs of cross-sectional area 10 mm^2 are required, a cable of four 2.5 mm^2 copper pairs can be used with the number of fibres needed. The required total copper cross-sectional area to feed a remote site is in the range 2.5 mm^2 to 25 mm^2 for 400 VDC, depending on the power required and the distance to be covered.

The cable can be shielded or unshielded. If screened, a drain wire is needed.

The overall jacket is made of PVC or thermoplastic elastomer-halogen-free (TPE-HF) material.

The cable design allows a small bend radius and excellent cable routing properties.

The following sheath marking has been developed:

COMPANY NAME_DD YY WW_MANUFACTURER_HYBRID (ref) XXXX_(number of fibres)
XX FO_(fibres type) XXXX + (number of conductors) XX x (cross-section) XX mm^2 ____ 400VDC
____(length)XXX

Insulation material: The material for insulation should be PE cross-linked, halogen free with the following identification: Red, Black.

The cable is easily identified with three red lines integrated on the sheath around the cable to indicate the presence of potential high voltage in the core. See Figure III.2.

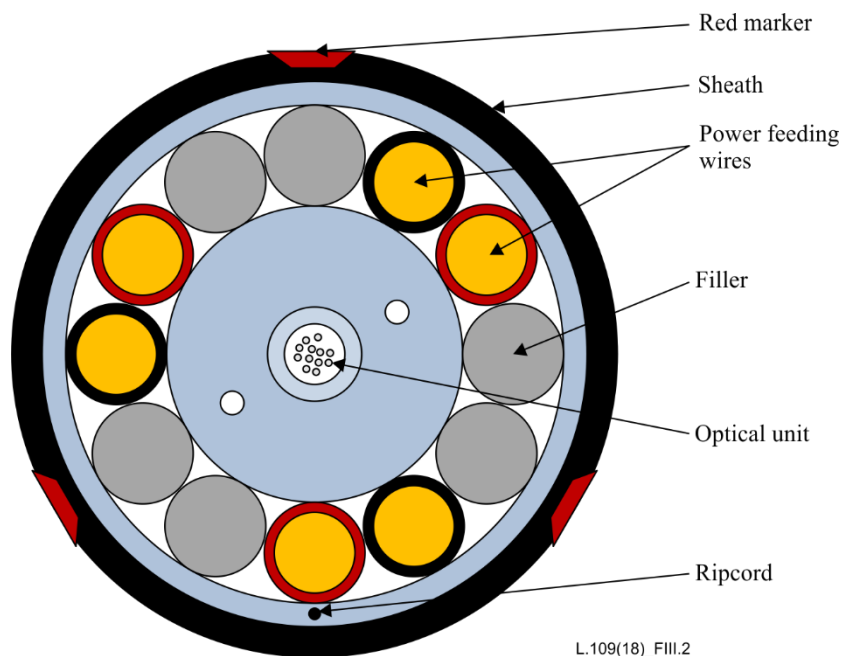

Figure III.2 – Example cross-section of the hybrid cable

Appendix IV

Swiss experience

(This appendix does not form an integral part of this Recommendation.)

IV.1 Introduction

The hybrid cable design in this appendix is an example of a typical construction that is used for RRH installations by several network operators. In the hybrid cable, optical fibres provide optical data communication and the copper conductors provide power feeding.

IV.2 Cable design

The cable, as shown in Figure IV.1, contains 12 copper conductors of American wire gauge (AWG) 6 mm² or 16 mm², a compact cable with 24 single-mode fibres, a drain wire, shielding and rip cords. The overall jacket is made of PVC or TPE-HF material.

The shielding of the hybrid cable, one layer (of thickness 0.05 mm) of 100% copper tape wrapped around the conductors and drain wire, enables the use of grounding kits between the base transmission station and the RRHs. The cable design allows a small bend radius and excellent cable routing properties.

The copper shield and the AWG 6 mm² or 16 mm² drain wire maintain contact throughout the cable run and ensure an appropriate earthing feature. The rip cords offer an easy and quick stripping of the cable jacket.

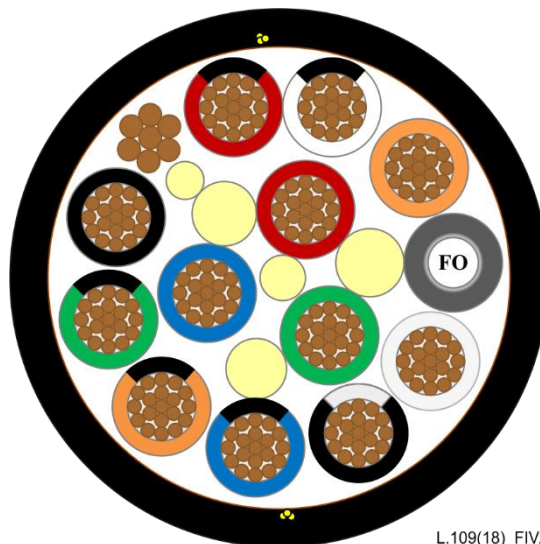

L.109(18)_FIV.1

Figure IV.1 – Cross-section of the hybrid cable

IV.3 Application

The cable configuration in Figure IV.1 enables up to six RRH to be connected. The cable has to perform well under outdoor thermal conditions and has to meet the specified fire performance requirements.

Such cables are used for dedicated cabling systems, which include a ruggedized enclosure and robust breakout-out cables open-ended or terminated with connectors. The cabling systems are usually factory terminated and supplied by cabling system manufacturers.

IV.4 Conclusion

A factory-terminated hybrid cabling system is an efficient and easy to install cabling solution. It can be installed in approximately half of the time of competitive hybrid solutions based on corrugated coax cable designs.

Bibliography

- [b-ITU-T G.651.1] Recommendation ITU-T G.651.1 (2018), *Characteristics of a 50/125 μm multimode graded index optical fibre cable for the optical access network.*
- [b-ITU-T TR-OFCS] ITU-T Technical Report TR-OFCS (2015), *Optical fibres, cables, and systems.*
- [b-ETSI EN 302 099] ETSI EN 302 099 V2.1.0 (2014), *Environmental engineering (EE); Powering of equipment in access network.*

SERIES OF ITU-T RECOMMENDATIONS

Series A	Organization of the work of ITU-T
Series D	Tariff and accounting principles and international telecommunication/ICT economic and policy issues
Series E	Overall network operation, telephone service, service operation and human factors
Series F	Non-telephone telecommunication services
Series G	Transmission systems and media, digital systems and networks
Series H	Audiovisual and multimedia systems
Series I	Integrated services digital network
Series J	Cable networks and transmission of television, sound programme and other multimedia signals
Series K	Protection against interference
Series L	Environment and ICTs, climate change, e-waste, energy efficiency; construction, installation and protection of cables and other elements of outside plant
Series M	Telecommunication management, including TMN and network maintenance
Series N	Maintenance: international sound programme and television transmission circuits
Series O	Specifications of measuring equipment
Series P	Telephone transmission quality, telephone installations, local line networks
Series Q	Switching and signalling, and associated measurements and tests
Series R	Telegraph transmission
Series S	Telegraph services terminal equipment
Series T	Terminals for telematic services
Series U	Telegraph switching
Series V	Data communication over the telephone network
Series X	Data networks, open system communications and security
Series Y	Global information infrastructure, Internet protocol aspects, next-generation networks, Internet of Things and smart cities
Series Z	Languages and general software aspects for telecommunication systems