

Superseded by a more recent version



INTERNATIONAL TELECOMMUNICATION UNION

ITU-T

TELECOMMUNICATION
STANDARDIZATION SECTOR
OF ITU

M.1400

(04/97)

SERIES M: TMN AND NETWORK MAINTENANCE:
INTERNATIONAL TRANSMISSION SYSTEMS,
TELEPHONE CIRCUITS, TELEGRAPHY, FACSIMILE
AND LEASED CIRCUITS

Designations and information exchange

Designations for international networks

ITU-T Recommendation M.1400

Superseded by a more recent version

(Previously CCITT Recommendation)

Superseded by a more recent version

ITU-T M-SERIES RECOMMENDATIONS

TMN AND NETWORK MAINTENANCE: INTERNATIONAL TRANSMISSION SYSTEMS, TELEPHONE CIRCUITS, TELEGRAPHY, FACSIMILE AND LEASED CIRCUITS

Introduction and general principles of maintenance and maintenance organization	M.10–M.299
International transmission systems	M.300–M.559
International telephone circuits	M.560–M.759
Common channel signalling systems	M.760–M.799
International telegraph systems and phototelegraph transmission	M.800–M.899
International leased group and supergroup links	M.900–M.999
International leased circuits	M.1000–M.1099
Mobile telecommunication systems and services	M.1100–M.1199
International public telephone network	M.1200–M.1299
International data transmission systems	M.1300–M.1399
Designations and information exchange	M.1400–M.1999
International transport network	M.2000–M.2999
Telecommunications management network	M.3000–M.3599
Integrated services digital networks	M.3600–M.3999
Common channel signalling systems	M.4000–M.4999

For further details, please refer to ITU-T List of Recommendations.

Superseded by a more recent version

ITU-T RECOMMENDATION M.1400

DESIGNATIONS FOR INTERNATIONAL NETWORKS

Summary

This Recommendation covers the designations of international circuits, groups, group and line links, digital blocks, digital paths, data transmission systems, digital blocks created between DCMEs, virtual containers and multiplex sections.

The designation information is in two layers:

- Layer 1: The unique information; the designation;
- Layer 2: Additional information; the related information.

Guidance for the user is provided in a series of examples.

Source

ITU-T Recommendation M.1400 was revised by ITU-T Study Group 4 (1997-2000) and was approved under the WTSC Resolution No. 1 procedure on the 19th of April 1997.

Keywords

Designation, Identification.

Superseded by a more recent version

FOREWORD

ITU (International Telecommunication Union) is the United Nations Specialized Agency in the field of telecommunications. The ITU Telecommunication Standardization Sector (ITU-T) is a permanent organ of the ITU. The ITU-T is responsible for studying technical, operating and tariff questions and issuing Recommendations on them with a view to standardizing telecommunications on a worldwide basis.

The World Telecommunication Standardization Conference (WTSC), which meets every four years, establishes the topics for study by the ITU-T Study Groups which, in their turn, produce Recommendations on these topics.

The approval of Recommendations by the Members of the ITU-T is covered by the procedure laid down in WTSC Resolution No. 1.

In some areas of information technology which fall within ITU-T's purview, the necessary standards are prepared on a collaborative basis with ISO and IEC.

NOTE

In this Recommendation, the expression "Administration" is used for conciseness to indicate both a telecommunication administration and a recognized operating agency.

INTELLECTUAL PROPERTY RIGHTS

The ITU draws attention to the possibility that the practice or implementation of this Recommendation may involve the use of a claimed Intellectual Property Right. The ITU takes no position concerning the evidence, validity or applicability of claimed Intellectual Property Rights, whether asserted by ITU members or others outside of the Recommendation development process.

As of the date of approval of this Recommendation, the ITU had/had not received notice of intellectual property, protected by patents, which may be required to implement this Recommendation. However, implementors are cautioned that this may not represent the latest information and are therefore strongly urged to consult the TSB patent database.

© ITU 1997

All rights reserved. No part of this publication may be reproduced or utilized in any form or by any means, electronic or mechanical, including photocopying and microfilm, without permission in writing from the ITU.

Superseded by a more recent version

CONTENTS

	Page
0 General.....	1
0.1 Layer 1	1
0.2 Layer 2	2
0.3 Layer 3	2
0.4 Implementation	2
1 Designations of international public switched circuits.....	3
1.1 General.....	3
1.2 Telephone-type circuits	4
1.2.1 General.....	4
1.2.2 Telephone circuits used in manual operation	5
1.2.3 One-way telephone circuits used for semi-automatic or automatic operation	5
1.2.4 Both-way telephone circuits used for semi-automatic or automatic operation	5
1.3 Circuit used for switched telex and telegraph services.....	6
1.4 Circuits in the international public switched data network	6
1.5 Related information	6
2 Related information for international public switched circuit.....	6
2.1 Urgency for restoration [item 1)].....	6
2.2 Terminal countries [item 2)].....	7
2.3 Names of Administrations or carriers [item 3)].....	7
2.4 Control station [sub-control station(s)] [item 4)].....	7
2.5 Fault report points [item 5)].....	8
2.6 Routing [item 6)]	8
2.7 Association [item 7)]	9
2.8 Equipment information [item 8)].....	9
2.9 Use [item 9)]	10
2.10 Transmission medium information [item 10)].....	10
2.11 Composition of the transmission [item 11)].....	10
2.12 Bandwidth or bit rate [item 12)]	11
2.13 Signalling type [item 13)].....	11
3 Designations of international fixed (non-switched) circuits.....	12
3.1 General.....	12
3.2 International leased circuits	12

Superseded by a more recent version

	Page	
3.2.1	General.....	12
3.2.2	Analogue leased circuits used for telephony.....	13
3.2.3	Analogue leased circuits used for telegraphy.....	13
3.2.4	Leased telegraph circuits.....	14
3.2.5	Analogue leased circuits used for data transmission.....	14
3.2.6	Analogue leased circuits used for phototelegraphy or facsimile.....	14
3.2.7	Analogue leased circuits used for sound-programme transmission.....	14
3.2.8	Analogue leased circuits used for television transmission.....	15
3.2.9	Leased circuits used for digital video transmission.....	15
3.2.10	Analogue leased circuits connecting circuit multiplication terminal equipments as renters' premises.....	15
3.2.11	Analogue leased circuits used for transmission other than those designated in the paragraphs above, or used for combinations of transmissions.....	15
3.2.12	Analogue leased circuits connecting three or more locations.....	16
3.2.13	Leased analogue groups, supergroups, etc.....	16
3.2.14	Leased analogue group, supergroup links.....	16
3.2.15	Digital leased circuits connecting two locations.....	17
3.2.16	Digital leased circuits connecting three or more locations.....	17
3.3	Fixed (non-switched) public circuits.....	18
3.3.1	General.....	18
3.3.2	Circuits used for sound-programme transmission.....	18
3.3.3	Circuits used for television transmission.....	19
3.3.4	Circuits for digital audio and video transmission.....	19
3.3.5	Telephone-type circuits used for phototelegraphy or facsimile.....	19
3.3.6	Telephone-type circuits used to provide voice-frequency telegraph links....	20
3.3.7	Telephone-type circuits used to provide TDM (Time Division Multiplex) telegraph systems.....	20
3.3.8	Telephone-type circuits used for data transmission.....	20
3.3.9	Telephone-type circuits used as transfer links for common channel Signalling Systems No. 6 and No. 7.....	20
3.4	Related information.....	21
4	Related information for international fixed circuits.....	21
4.1	Urgency for restoration [item 1]).....	21
4.2	Terminal countries [item 2]).....	22
4.3	Names of Administrations, carriers or broadcasting companies [item 3]).....	22
4.4	Control station [sub-control station(s)] [item 4]).....	22
4.5	Fault report points [item 5]).....	23
4.6	Routing [item 6]).....	23

Superseded by a more recent version

	Page
4.7	Association [item 7)] 24
4.8	Equipment information [item 8)] 25
4.9	Use [item 9)] 25
4.10	Transmission medium information [item 10)] 25
4.11	Composition of the transmission [item 11)] 26
4.12	Bandwidth or bit rate [item 12)] 26
4.13	Signalling type [item 13)] 27
4.14	Applicable CCITT/ITU-T Recommendations [item 14)] 27
5	Designations of international groups, supergroups, etc. (bidirectional and unidirectional) 27
5.1	General 27
5.2	Bidirectional groups, etc. 28
5.2.1	Group 28
5.2.2	Supergroup 29
5.2.3	Mastergroup 29
5.2.4	Supermastergroup 29
5.2.5	Use of the groups, etc. 29
5.2.6	Restoration groups and supergroups 29
5.3	Unidirectional groups and supergroups 30
5.3.1	Multiple destination unidirectional groups and supergroups 30
5.3.2	Single destination unidirectional groups and supergroups 30
5.4	Related information 31
6	Designations of international group links, supergroup links and line links 31
6.1	Group and supergroup links 31
6.1.1	Conventional links not connected to their terminal equipment 31
6.1.2	Restoration links 31
6.2	Line links 32
6.3	Related information 33
7	Related information for international groups, group links and line links 33
7.1	Urgency for restoration [item 1)] 33
7.2	Terminal countries [item 2)] 34
7.3	Names of Administrations, carriers or broadcasting companies [item 3)] 34
7.4	Control station [sub-control station(s) [item 4)] 34
7.5	Fault report points [item 5)] 35
7.6	Routing [item 6)] 36

Superseded by a more recent version

	Page
7.7	Association [item 7] 36
7.8	Equipment information [item 8]..... 37
7.9	Use [item 9)] 37
7.10	Transmission medium information [item 10)]..... 37
7.11	End-to-end information (for mixed analogue/digital routes only) [item 11)] 38
7.12	Bandwidth [item 12)]..... 38
7.13	Occupancy (for groups/supergroups, etc., and for line links) [item 13)] 38
8	Designations of international digital blocks (bidirectional and unidirectional) 39
8.1	General..... 39
8.2	Bidirectional digital blocks..... 41
8.2.1	Symmetrical configuration 41
8.2.2	Asymmetrical configuration 41
8.3	Restoration digital blocks 41
8.4	Multiple destination unidirectional digital blocks 41
8.5	Single destination unidirectional digital blocks..... 42
8.6	Related information 42
9	Designation of international digital paths..... 43
9.1	Conventional digital paths not connected to their terminal equipment..... 43
9.2	Restoration digital paths 43
9.3	Digital line sections and digital radio sections 43
9.4	Related information 43
10	Designations of routes in the mixed analogue/digital transmission network 44
10.1	Transmission routes with one analogue-to-digital conversion..... 44
10.1.1	Groups and supergroups, etc., forming part of a mixed analogue/digital transmission route..... 44
10.1.2	Digital blocks and paths forming part of a mixed analogue/digital transmission route..... 44
10.1.3	End-to-end designations 45
10.2	Transmission routes with two analogue-to-digital conversions 45
10.2.1	End-to-end designations 45
10.2.2	Intermediate section designation 46
10.3	Transmission routes with more than two analogue-to-digital conversions 46
10.4	Related information 46
11	Designation of data transmission systems 46
11.1	General..... 46

Superseded by a more recent version

	Page
11.2	Data transmission links 49
11.3	Related information 49
12	Designations of international digital blocks created by the interconnection of Digital Circuit Multiplication Equipments (DCMEs) 50
12.1	General..... 50
12.2	Multi-clique configuration of DCMEs 51
12.3	Low Rate Encoding Equipment..... 52
12.4	Related information 52
13	Designations of international Virtual Containers 52
13.1	General..... 52
13.2	Related information 53
14	Designation of multiplex sections of the Synchronous Digital Hierarchy (SDH)..... 54
14.1	General..... 54
14.2	Related information 55
15	Related information for international digital blocks, paths, data transmission systems, blocks created by the interconnection of DCMEs, Virtual Containers and SDH multiplex sections 55
15.1	Urgency for restoration [item 1)]..... 55
15.2	Terminal countries [item 2)] 56
15.3	Names of Administration, carriers or broadcasting companies [item 3)]..... 56
15.4	Control station [sub-control station(s)] [item 4)]..... 57
15.5	Fault report points [item 5)]..... 57
15.6	Routing [item 6)] 58
15.7	Association [item 7)] 59
15.7.1	Information on reserve blocks, paths, data transmission systems created digital blocks between DCMEs, Virtual Containers and multiplex sections 59
15.7.2	Information on diverse routing..... 59
15.7.3	Information on consecutive routing..... 59
15.8	Equipment information [item 8)]..... 60
15.8.1	This item records information on equipment in the block, path, etc., which requires special maintenance attention 60
15.8.2	For data transmission systems, this item supplies information about the multiplex configuration 60
15.8.3	For blocks created by the interconnection of DCMEs, this item provides information on through-going channels (which are transmitted even if a DCME fails) and derived channels (which are not transmitted if a DCME fails) 61

Superseded by a more recent version

	Page
15.9 Use [item 9])	61
15.10 Transmission medium information [item 10]).....	61
15.11 End-to-end information or composition of transmission [item 11]).....	62
15.11.1 End-to-end information (for blocks and paths on mixed analogue/digital routes only).....	62
15.11.2 Composition of transmission (for data transmission systems).....	62
15.12 Bit rate (for blocks, paths and SDH multiplex sections) [item 12]).....	62
15.13 Occupancy (except for paths) [item 13])	63
15.14 Actual number of channels and access point identifier [item 14]).....	65
15.14.1 Actual number of channels (primary blocks only).....	65
15.14.2 Access point identifiers (virtual containers and SDH multiplex sections)....	66
15.15 Clocking information (for blocks only) [item 15]).....	67
15.16 Direction of transmission (for unidirectional blocks) [item 16]).....	67
16 Designation of connections for the Asynchronous Transport Mode (ATM)	68
16.1 General.....	68
16.2 Transport Links.....	68
16.3 Virtual path	69
16.4 Virtual channels	69
Annex A – Full examples for designation information.....	70
A.1 Full example for the designation information of a public switched telephone circuit	70
A.2 Full example for the designation information of a leased analogue circuit.....	71
A.3 Full examples for the designation information of an international group and an international group link.....	71
A.3.1 Full example for the designation information of an international group.....	71
A.3.2 Full example for the designation information of an international group link	72
A.4 Full examples for the designation information of an international digital block, digital path, data transmission system, blocks created between DCMEs, Virtual Containers and SDH multiplex sections	73
A.4.1 Full example for the designation information of an international digital block (bidirectional)	73
A.4.2 Full example for the designation information of an international digital path	77
A.4.3 Full example for the designation information of an international data transmission system.....	77
A.4.4 Full example for the designation information of a block created by the interconnection of DCMEs.....	78
A.4.5 Full example for the designation of an international Virtual Container.....	79
A.4.6 Full example for the designation information of an international multiplex section.....	80

Superseded by a more recent version

Page

Annex B – KLM addressing and its relationship to time slot numbering for virtual containers 81	
B.1 KLM addressing relationship to time slot numbering	81
B.2 KLM addressing of VC4 occupancy	81
B.3 Comparative notation of KLM addressing vs. time slot numbering.....	82
Annex C – Reference subclause numbers for the various types of routes.....	84
Annex D – Alphabetical list of abbreviations used in this Recommendation	87
Annex E – Numbering of channels in data transmission systems	88

Superseded by a more recent version

Recommendation M.1400

DESIGNATIONS FOR INTERNATIONAL NETWORKS

(Circuits, groups, group and line links, digital blocks, digital paths, data transmission systems, digital blocks created between DCMEs, virtual containers, multiplex sections and related information)

(Published as M.13, 1960; renumbered as M.14, 1964, as M.140, 1972 and as M.1400, 1992; revised 1964, 1972, 1976, 1980, 1984, 1992 and 1997)

0 General

Designation of international routes¹ are of great importance for identification and information.

Technical developments, especially those due to digital technology, have brought a much greater variety of techniques and allow for a more efficient use of equipment.

Information on the equipment and techniques used is of great interest to staff working in the field of maintenance and operation. Present operational conditions can be more complicated than those previously, e.g. as a consequence of greater competition in the field of telecommunication. Another consideration is automated file handling which is often a necessity for Administrations and the standardization of designation is an important factor to facilitate this.

To cover the need for standardized designations which are easy to handle but which give precise information, the designation information is built up from two layers:

- Layer 1 provides the unique identification: the designation;
- Layer 2 provides the necessary additional information which must be known at both terminations of the routes: the related information.

If Administrations need more route data to be stored, they are free to create independently or bilaterally a third layer for which no standardization is intended for the time being.

0.1 Layer 1

The general format of layer 1 for the designation of all types of international routes is shown in Table 1.

¹ The term "routes" is used in this text to cover all types of telecommunication connections: circuits, groups, blocks, etc.

Superseded by a more recent version

Table 1/M.1400

Format of designation	Town A	/	Suffix	–	Town B	/	Suffix		Function code	Serial number
Signs	Characters	Slash	Letters/digits	Hyphen	Characters	Slash	Letters/digits	Space	Letters/digits	Digits
Number of characters	≤ 12	1	≤ 3	1	≤ 12	1	≤ 3	1	≤ 6	≤ 4
									↑	No space

The use of suffixes applies particularly to international public switched circuits. Their use is recommended for all new and changed records, though optional for international non-switched circuits, groups, group links, digital blocks and paths and data transmission systems. Such use will be required as competition is arriving at many countries of the world, thus bringing multiple carriers to the same towns. A suffix provides for independent sequential numbering plan in case there is more than one carrier operating in the town.

The first part of the designation, the traffic relation, presents the origin and destination of a route. The function code shows the type of route whilst the serial number counts the routes (i.e. circuits, groups, digital blocks, etc.) within the same traffic relation and same function code.

If a town name exceeds 12 characters, Administrations should apply a suitable abbreviation which should be unique.

If identical place names occur in different countries, and if confusion is likely to arise, the Administrations concerned should agree to identify the country in the designation by adding after the place name a three-letter country code as defined in ISO 3166 [2]. This country code must be included within the 12 characters of the town name, if necessary by providing an abbreviation of the town name.

The serial number should be written without leading zeros.

0.2 Layer 2

The general format for layer 2 (related information) is as follows:

- 1 ..., ...;
- 2 ..., ...;
- 3 ..., ...; etc.

The numbers identifying the fields in layer 2 indicate the various items. Each item provides information on the route, e.g. *operational*: operating companies and control station, etc. or *technical*: analogue/digital, use of special equipment, etc. The items provide flexibility in designation information because they can be extended in the future if there is a need.

0.3 Layer 3

Not subject to standardization at the present time.

0.4 Implementation

Where designations do not comply with this Recommendation, e.g. due to out-dated rules, Administrations are recommended to change such designations.

Superseded by a more recent version

To facilitate the change, Administrations with control station responsibility should prepare proposals containing designations conforming to layer 1 and propose the items of related information to be included in layer 2.

Agreement should then follow on the designation as well as an exchange of the agreed layer 2 information.

Administrations will need to ensure that the layer 2 related information is kept up to date and that other concerned Administrations are informed of any changes.

1 Designations of international public switched circuits

1.1 General

The format of the designation of public switched circuits is shown in Table 2.

The elements of the format are as follows:

a) *Traffic relation*

Towns A and B (maximum 12 characters or space) (see Note 1) refer to the names of the two towns in which the international exchanges of the circuit are located. The place names in all types of designations should always be written in Roman characters taking the official name of a town as used in the country to which it belongs (see 0.1).

The international exchange suffix (maximum 3 alpha-numeric characters) is indicated by letters, digits or a combination. The suffix will refer to the whole exchange (to the building or to a part of it) (see Note 2). It will be chosen by the Administration (see Notes 3, 4 and 5).

Table 2/M.1400

Format of designation	Town A	/	International exchange suffix	–	Town B	/	International exchange suffix		Function code	Serial number
Signs	Characters	Slash	Letters/digits	Hyphen	Characters	Slash	Letters/digits	Space	Letters	Digits
Number of characters	≤ 12	1	≤ 3	1	≤ 12	1	≤ 3	1	1 or 2	≤ 4
									↑	No space

b) *Function code* (1 or 2 alphabetical characters)

The function code indicates the type of circuit.

c) *Serial number* (maximum 4 numeric characters)

The serial numbering starts anew if there is a difference in:

- town A or town B;
- international exchange suffix;
- function code.

NOTE 1 – If the name of the town exceeds 12 characters, the responsible Administration will supply an appropriate abbreviation, which should be unique.

NOTE 2 – In the example given in Figure 1, there may be only one suffix or three to be decided by the Administration.

Superseded by a more recent version

NOTE 3 – The 3 alphanumeric characters make it possible to include carrier's name information in the suffix, e.g. Tokyo/SJK: the international exchange in Tokyo–Shinjuku where the K in the suffix reflects the responsible carrier KDD.

NOTE 4 – The different companies operating in the same town have to agree on the suffixes used, in order that they be different.

NOTE 5 – The suffix may be used to denote different exchanges in the same building as well as different carriers in the same building.

Example 1:

Three KDD exchanges in the same building:

Exchange 1 Tokyo/S1K

Exchange 2 Tokyo/S2K

Exchange 3 Tokyo/S3K

Example 2:

Two exchanges in the same building, one from Telecom Italia and one from T.I.M. (two different operators in the same building in the North Area of Rome), the designations can be:

Roma/N1I

Roma/N1M or Roma/N2M

The exact suffix codes have to be identified by the operators involved.

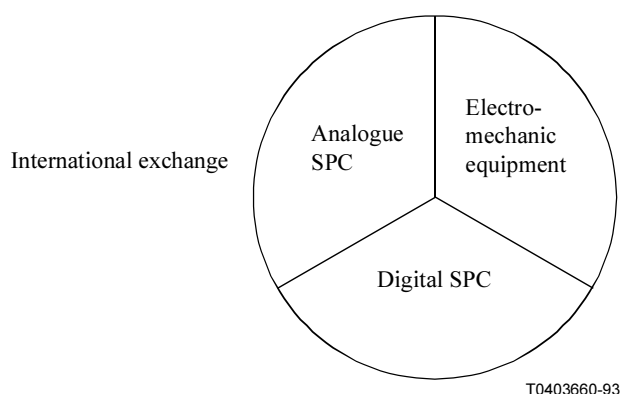

Figure 1/M.1400

1.2 Telephone-type circuits

1.2.1 General

Possible function codes are:

M manual telephone circuits;

Z automatic and semi-automatic telephone circuits in one-way operation;

B both-way telephone circuits.

Superseded by a more recent version

The serial number has a maximum of 4 numeric characters. Serial numbering starts anew if there is a difference in:

- town A or town B;
- international exchange suffix²;
- function code.

1.2.2 Telephone circuits used in manual operation

The terminal points of the circuit are arranged in alphabetical order.

The function code is: M.

Example:

The first telephone circuit for manual operation between London Keybridge and Paris Bagnolet is designated:

London/KB–Paris/BA M1.

1.2.3 One-way telephone circuits used for semi-automatic or automatic operation

The terminal points of the circuits are arranged in the order according to the direction of operation of the circuit.

The function code is: Z.

Serial numbering: Circuits operated in the direction corresponding to the alphabetical order of the terminations should have odd numbers. Circuits operated in the direction corresponding to an inverse alphabetical order of the terminations should have even numbers.³

Examples:

The 11th circuit operated in the London Mollison to Montreal 1TE direction (alphabetical order of towns) is designated:

London/SM–Montreal/1TE Z21.

The 9th circuit operated in the Montreal 1TE to London Mollison direction (inverse alphabetical order of towns) is designated:

Montreal/1TE–London/SM Z18.

1.2.4 Both-way telephone circuits used for semi-automatic or automatic operation

The terminal points of the circuit are arranged in alphabetical order.

The function code is: B.

Example:

The first both-way circuit between London Kelvin and New York 24 is designated:

London/J–New York/24 B1.

² By bilateral agreement, Administrations may wish to apply a serial number to telephone-type circuits on a town-to-town basis rather than on an exchange-to-exchange basis.

³ By bilateral agreement, Administrations may wish to apply continuous serial numbering on Z + B circuits.

Superseded by a more recent version

1.3 Circuit used for switched telex and telegraph services

See Recommendation R.70 [3].

1.4 Circuits in the international public switched data network

The terminations of the circuit are arranged in alphabetical order.

The function code is: XD.

Example:

The first international public switched data circuit between Oslo A and Stockholm HYX is designated:

Oslo/A–Stockholm/HYX XD1.

1.5 Related information

The additional information on public switched circuits is covered by the following items:

- 1) urgency for restoration;
- 2) terminal countries;
- 3) Administrations' or carriers' names;
- 4) control and subcontrol station(s);
- 5) fault report points;
- 6) routing;
- 7) association;
- 8) equipment information;
- 9) use;
- 10) transmission medium information;
- 11) composition of transmission;
- 12) bandwidth or bit rate;
- 13) signalling type.

The various items will be dealt with in clause 2.

2 Related information for international public switched circuit

The following subclauses explain the items of related information concerned with international public switched circuits. A full example for the designation information of an international public switched telephone circuit is given in A.1.

2.1 Urgency for restoration [item 1)]

This item supplies information on the urgency of restoration of the circuit based upon bilateral agreement between the terminal Administrations.

Format:

1. xxx xx; (maximum 10 characters)

Superseded by a more recent version

Illustration:

- a) if the priority is top: 1;
if the priority is second: 2;
if the priority is third: 3; or
- b) if repair is required within e.g. 24 hours: ≤ 24 h; or
- c) if no urgency has to be indicated: –;

2.2 Terminal countries [item 2]

This item presents the countries in which the circuit is terminating.

Format:

- 2. XXX, YYY; (3 characters for each)

Specification:

XXX: code for country of town A

YYY: code for country of town B

NOTE – The codes are according to ISO Standard 3166 [2].

Example:

For the circuit London/KB–Tokyo/SJK Z101:

- 2. GBR, JNP;

2.3 Names of Administrations or carriers [item 3]

This item records the names of the Administrations or carriers which operate the circuit.

The applicable carrier codes can be selected from the ITU-T "List of International Carrier Codes" [22].

Format:

- 3. YYYYYY, ZZZZZZ; (maximum 6 characters for each)

Specification:

YYYYYY: code for company operating in town A

ZZZZZZ: code for company operating in town B

Example:

For the circuit London/KB–Tokyo/SJK Z101 operated by BTI and KDD:

- 3. BTI, KDD;

2.4 Control station [sub-control station(s)] [item 4]

This item lists the appointed control station and sub-control stations (according to Recommendations M.80 [15] and M.90 [16]). Further details about the stations can be found in the list of contact points (Recommendation M.1510 [17]).

Superseded by a more recent version

Format:

- 4. CS: designation of control station,
- SCS1: designation of sub-control station,
- SCS2: designation of sub-control station,
- ⋮ ⋮
- SCSn: designation of sub-control station.

Specification:

- CS: designation of the control station,
- SCS1: designation of the terminal sub-control station,
- SCS2 to SCSn: if applicable, other sub-control stations have to be placed in the geographical order according to the traffic relation.

Example:

For the circuit New York/10–Stockholm/1 B1 where New York is the control station and sub-control stations are in London and Stockholm:

- 4. CS: New York,
- SCS1: Stockholm,
- SCS2: London;

2.5 Fault report points [item 5]

This item presents the names of both fault report points on the circuit. Further information about the fault report points can be found in the list of contact points (Recommendation M.1510 [17]).

Format:

- 5. Designation of fault report point, designation of fault report point;

Specification:

The first report point is that of the country of town A.

The second fault report point is that of the country of town B.

Example:

For the circuit London/M–Reims/IP1 Z999 with fault report points in London M and Reims XRE:

- 5. London/M, Reims/XRE;

2.6 Routing [item 6]

This item shows the international primary group(s) or primary block(s) and channel number(s) which carry the circuit. If there are more than one, the groups or blocks appear in the geographical order from town A to town B.

Format:

- 6. Designation of an international primary group or primary block/channel number, designation of a primary group/channel number, ..., designation of a primary group/channel number;

NOTE – Primary groups or blocks can be unidirectional as well. Two consecutive unidirectional groups or blocks are separated by a + sign instead of a comma.

Superseded by a more recent version

Example:

For a circuit London/KB–Santiago/1 Z27:

6. London–Paris 1204/4, Paris–(MU) 1202/2+Santiago–(MU) 1203/3;

2.7 Association [item 7]

This item informs whether there are associated circuits and if so, of which nature.

Format:

7. Association code: designation of associated circuit;

Specification:

If the circuit *has* a reserve circuit, the association code is: S followed by the function code and the serial number of the principal circuit.

If the circuit *is* a reserve circuit, the association code is: function code followed by S and the serial number of the reserve circuit.

Example 1:

7. ZS13: Roma/AS1–Zuerich/SEL T1;

which indicates that the actual circuit Z13 is a reserve circuit for the circuit Roma/AS1–Zuerich/SEL T1.

If the circuit belongs to a group of circuits for which the time slot sequential order (end-to-end) must be guaranteed, the association code is: TSG. The designations of the associated circuits are abbreviated by taking the function code of the circuits followed by the lowest sequential number, a hyphen and the highest sequential number.

Example 2:

If the circuit Sherman Oaks/4ES–Singapore/EST B607 belongs to a group of 30 circuits for which the time slot sequential order must be guaranteed, the association is: 7. TSG: B601-630;

2.8 Equipment information [item 8]

This item records any equipment in the circuit which requires special maintenance attention.

Format:

8. XX, XX, XX, XX, XX;

Specification:

If the circuit has been routed via analogue circuit multiplication equipment: AM

If the circuit has been routed via digital circuit multiplication equipment:

- using reduced bit rate encoding: RB
- using speech interpolation: SI

If the circuit has a compandor: CO

If the circuit has an echo suppressor: ES

If the circuit has an echo canceller: EC

If the circuit has an echo suppressor in terminal country of town A and an echo canceller in terminal country of town B: ES, EC (any combination of EC and ES is possible).

Superseded by a more recent version

If the circuit is a bearer circuit: BC

If the circuit is a derived circuit: DC

NOTE 1 – If there is a need to record an additional special equipment, additional codes can be used by bilateral agreement between the Administrations. The codes must be unique and shall have two characters.

NOTE 2 – A bearer circuit refers to the circuit type that continues to be provided in the case of a breakdown of the circuit multiplication equipment. For a derived circuit, this is not the case.

2.9 Use [item 9]

This item supplies information on the usage of the circuit. It concerns the role of the circuit in the traffic (e.g. belonging to a final route) and the usage of the circuit made by the user.

Format:

9. XX, YYYY; (maximum 7 characters)

Specification:

XX refers to the type of traffic carried by the circuit:

- if it belongs to an overflow group of circuits: OF
- if it belongs to a transit group of circuits: TR
- if the information is not known: –

YYYY refers to the use of the circuit:

- in the case where a public telephone circuit is used for phototelegraphy or facsimile: F
- in the case where such a circuit is occasionally used for narrow-band sound programme transmission: RK.

2.10 Transmission medium information [item 10]

This item identifies whether a satellite is involved in the routing of the circuit.

Format:

10. ST; or –;

Specification:

If the circuit has been routed via satellite: ST

If the circuit is not being routed via satellite: –

Example:

For the circuit Amsterdam/2H–New York/24 Z33 routed partly via satellite:

10. ST;

2.11 Composition of the transmission [item 11]

This item shows the type of transmission on the circuit.

Format:

11. A; or N; or C;

Superseded by a more recent version

Specification:

If the transmission is analogue: A

If the transmission is digital: N

If the transmission is mixed analogue/digital: C

2.12 Bandwidth or bit rate [item 12]

This item shows the bandwidth (in the case of an analogue or mixed circuit) or the bit rate (in the case of a digital circuit).

Format:

12. xxxx.x Hz; or kHz; or MHz; bit/s; or kbit/s; or Mbit/s;

Rule for the notation of the figures:

Leading zeros may be omitted, and if the decimal is a zero, this decimal and the decimal point may also be omitted.

If the figure is up to 999, use Hz, bit/s.

If the figure is between 1000 and 9 999 999, use kHz, kbit/s.

If the figure is 10 000 000 or more, use MHz, Mbit/s.

Specification:

If the circuit is analogue or mixed analogue/digital: the bandwidth in Hz, kHz, MHz.

If the circuit is digital: the bit rate in bit/s, kbit/s, Mbit/s.

2.13 Signalling type [item 13]

This item presents the signalling information that applies to the circuit.

Format:

13. xx xx; (maximum 20 characters).

Specification:

If the signalling is of the type xxxx Hz/xx Hz: xxxx/xx

If the CCITT Signalling System R2 is applied: R2

If the CCITT Signalling System R2-digital is applied: R2D

If the CCITT Signalling System No. 4 is applied: C4

If the CCITT Signalling System No. 5 is applied: C5

If the CCITT Signalling System No. 6 is applied: C6, xxx/yy where xxx/yy refers to band and circuit number respectively.

If the CCITT Signalling System No. 7 is applied: C7, xxxx, Y-YYY-Y, Z-ZZZ-Z where xxxx refers to the Circuit Identification Code (CIC).

Y-YYY-Y refers to the International Signalling Point Code (ISPC) for town A/international exchange.

Z-ZZZ-Z refers to the ISPC for town B/international exchange.

Example:

For a circuit with C6-signalling type and being the 7th circuit in band number 32:

13. C6, 032/06; (circuit counting starts at 0).

Superseded by a more recent version

3 Designations of international fixed (non-switched) circuits

3.1 General

The designations of leased circuits and public fixed circuits are treated in 3.2 and 3.3 respectively. The format of the designation of fixed circuits is shown in Table 3.

Table 3/M.1400

Format of designation	Town A	/	Transmission station ^{a)} suffix (optional)	–	Town B	/	Transmission station ^{a)} suffix (optional)		Function code	Serial number
Signs	Characters	Slash	Letters/digits	Hyphen	Characters	Slash	Letters/digits	Space	Letters/digits	Digits
Number of characters	≤ 12	1	≤ 3	1	≤ 12	1	≤ 3	1	1 to 4	≤ 4
									↑ No space	
a) For some circuits, the international exchange may be more suitable (see 3.3.9 and 3.2.15, Note 2).										

The elements of the format are as follows:

a) *Traffic relation*

Towns A and B, possibly with a transmission station suffix, identify the terminals of the circuit. The identification of the terminal is up to the Administration concerned. In the case where a town name exceeds the maximum length of 12 characters, the Administration should supply a suitable abbreviation which must be unique (see 0.1).

The transmission station suffix (maximum 3 characters), although optional, is recommended for all new and modified records. The suffix may be used to further identify the terminal point of the international carrier providing the circuit, when there is more than one carrier operating in the town.

b) *Function code* (maximum 4 characters)

This code identifies the type of the circuit; see 3.2 and 3.3.

c) *Serial number* (maximum 4 digits)

There should be a separate serial numbering series for each traffic relation and function code. In case of more than one carrier in the town, the serial numbering will be on a transmission station to transmission station basis.

The designations of the different categories of leased circuits are given below. In special cases in which CCITT/ITU-T Recommendations do not apply, agreement should be reached between the terminal Administrations.

3.2 International leased circuits

3.2.1 General

Leased circuits are fixed circuits for private services or particular purposes. They are distinguished by the letter P.

Superseded by a more recent version

The designation format for leased circuits is as stated in 3.1. Possible function codes are:

- P for analogue leased circuits used wholly for telephony;
- TP for analogue leased circuits used for voice-frequency telegraphy;
- TDP for analogue leased circuits used for TDM-telegraphy;
- DP for analogue leased circuits used wholly for data transmission;
- FP for analogue leased circuits used wholly for phototelegraphy or facsimile;
- RP for analogue leased unidirectional sound-programme circuits;
- RRP for analogue leased reversible sound-programme circuits;
- VP for analogue leased unidirectional television-programme circuits;
- VVP for analogue leased reversible television-programme circuits;
- XP for analogue leased circuits used for multiple type transmissions;
- NP for digital leased circuits.

NOTE 1 – In case of leased circuits connecting three or more locations, the letter M should follow these function codes.

NOTE 2 – Whether these circuits make use of analogue or digital transmission not relevant for the above codes, the service is coded.

NOTE 3 – For digital leased circuits, the actual use is not relevant; all are coded as NP.

3.2.2 Analogue leased circuits used for telephony

The terminal points of the circuits are arranged in alphabetical order.

The function code is: P.

Example:

The first analogue leased circuit used for telephony between Paris and Wellington (New Zealand) is designated:

Paris–WellingtonNZL P1.

3.2.3 Analogue leased circuits used for telegraphy

3.2.3.1 Voice-frequency telegraphy

The terminal points of the circuits are arranged in alphabetical order.

The function code is: TP.

Example:

The first analogue leased circuit used for voice-frequency telegraphy between Bern 1RS and New York 1RC is designated:

Bern/1RS–New York/1RC TP1.

3.2.3.2 TDM-telegraphy

The terminal points of the circuits are arranged in alphabetical order.

The function code is: TDP.

Superseded by a more recent version

Example:

The 3rd analogue leased circuit used for TDM-telegraphy between London and Montreal is designated:

London–Montreal TDP3.

3.2.4 Leased telegraph circuits

See Recommendation R.70 [3].

3.2.5 Analogue leased circuits used for data transmission

The terminal points of the circuits are arranged in alphabetical order.

The function code is: DP.

Example:

The 3rd analogue leased circuits used for data transmission between London and Paris is designated:

London–Paris DP3.

3.2.6 Analogue leased circuits used for phototelegraphy or facsimile

The terminal point of the circuits are arranged in alphabetical order.

If these circuits are different from P-circuits, the function code is: FP.

Example:

The 2nd analogue leased circuits used for phototelegraphy between London and Paris is designated:

London–Paris FP2.

If normal P-circuits are used, then these circuits are designated accordingly.

3.2.7 Analogue leased circuits used for sound-programme transmission

3.2.7.1 Analogue leased unidirectional sound-programme circuit

The terminal points of the circuits are arranged in the order corresponding to the direction of transmission (instead of alphabetically, if this is different).

The function code for these circuits is: RP.

Serial numbering: Circuits which transmit in the direction corresponding to the alphabetical order of the terminals should have odd serial numbers, circuits in the other direction even numbers.

Examples:

The first leased sound-programme circuit transmitting in the direction Montreal to Wellington (New Zealand) will be designated:

Montreal–WellingtonNZL RP1.

The first leased sound-programme circuit transmitting in the direction Wellington (New Zealand) to Montreal will be designated:

WellingtonNZL–Montreal RP2.

3.2.7.2 Analogue leased reversible sound-programme circuits

The terminal points of the circuits are arranged in alphabetical order.

The function code is: RRP.

Superseded by a more recent version

Example:

The first leased circuit with reversible sound-programme transmission between Montreal and Wellington (New Zealand) is designated:

Montreal–WellingtonNZL RRP1.

3.2.8 Analogue leased circuits used for television transmission

3.2.8.1 Analogue leased unidirectional television-programme circuits

The terminal points of the circuit are arranged in the order corresponding to the direction of transmission (instead of alphabetically, if this is different).

The function code is: VP.

Serial numbering: Circuits which transmit in the direction corresponding to the alphabetical order of the terminals should have odd serial numbers, circuits in the other direction even numbers.

Example:

The first leased television programme circuit transmitting in the direction Wellington (New Zealand) to Montreal will be designated:

WellingtonNZL–Montreal VP2.

3.2.8.2 Analogue leased reversible television-programme circuits

The terminal points of the circuits are arranged in alphabetical order.

The function code is: VVP.

Example:

The first circuit with reversible television transmission between Montreal and Wellington (New Zealand) is designated:

Montreal–WellingtonNZL VVP1.

3.2.9 Leased circuits used for digital video transmission

These circuits are designated as digital leased circuits (irrespective of the use), see 3.2.15 and 3.2.16.

3.2.10 Analogue leased circuits connecting circuit multiplication terminal equipments as renters' premises

These circuits are designated as normal leased circuits. The information indicating that these circuits connect circuit multiplication terminal equipment can be recorded under item 9 (Use) of related information (see 4.9).

Circuits routed via circuit multiplication equipment are also designated as normal circuits. The multiplication equipment appears under item 8 (Equipment information) of related information (see 4.8).

3.2.11 Analogue leased circuits used for transmission other than those designated in the paragraphs above, or used for combinations of transmissions

In this category are circuits used for different transmissions at different times, or circuits in which the bandwidth is divided into two or more bands, thus providing two or more derived circuits which may be used for different transmissions.

The terminal points of the circuits are arranged in alphabetical order.

Superseded by a more recent version

The function code is: XP.

Example:

Bruxelles–Paris XP8.

3.2.12 Analogue leased circuits connecting three or more locations

Various types and configurations of multiterminal circuits fall into this category. Each section of the circuit should have a unique designation. A section is any part of the circuit which connects a branching point to either a customer terminal or another branching point.

International sections should use the designation described below.

The terminal town points of each section are arranged in alphabetical order.

The function code is formed by adding the letter M to the function codes recommended in 3.2.2 to 3.2.11. This leads, in principle, to the function codes PM, TPM, TDPM, DPM, FPM, RPM, RRPM, VPM, VVPM and XPM.

The association between sections should be recorded in the related information of each section under item 7 (Association) (see 4.7).

Wholly national sections with national designations may be included if bilaterally agreed.

Example:

Let there be an international multiterminal leased circuit connecting Bruxelles and Paris (7th PM circuit between Bruxelles and Paris) with branches from Bruxelles to Edinburgh (1st PM-circuit on this relation) and from Bruxelles to Aachen (4th PM-circuit) and with an extension from Paris to Marseilles.

The international sections are designated:

Bruxelles–Edinburgh PM1

Aachen–Bruxelles PM4

Bruxelles–Paris PM7.

3.2.13 Leased analogue groups, supergroups, etc.

These groups, supergroups, etc., will receive a circuit type designation. The additional information on the constitution of these leased groups, supergroups, etc., is to be recorded in related information under item 12 (Bandwidth or bit rate) (see 4.12) and under item 6 (Routing) (see 4.6).

The function codes are according to the relevant codes for circuits.

Example:

A supergroup between renters' premises in London and Paris for data transmission which is the 15th lease circuit for data transmission on this relation, is designated:

London–Paris DP15.

3.2.14 Leased analogue group, supergroup links

These group and supergroup links will receive a circuit type designation. The additional information on the constitution of these leased group, supergroup links, etc., is to be recorded in related information under item 12 (Bandwidth or bit rate) (see 4.12) and under item 6 (Routing) (see 4.6).

Superseded by a more recent version

Example:

A group link provided between renters' premises in London and Montreal devoted to data transmission which is the 10th leased circuit for data transmission on this relation, is designated:

London–Montreal DP10.

3.2.15 Digital leased circuits connecting two locations

Destinations given below also apply for leased digital blocks and paths.

NOTE 1 – For digital leased circuits, the use of the circuit will no longer be taken into account for the designation: the use may change without notification to the Administration or may be unknown.

The additional information concerning the bit rate is to be found in related information under item 12 (Bandwidth or bit rate) (see 4.12).

The terminations of the circuit are placed in alphabetical order.

The function code is: NP.

Example:

The 5th digital leased circuit between Birmingham and Toulouse is designated:

Birmingham–Toulouse NP5.

NOTE 2 – It may happen that a digital leased circuit has been routed via one or more international exchanges; in this case, they are designated as normal digital leased circuits. However, in such cases, an international exchange suffix may replace the transmission station suffix. The information concerning the permanent switched mode is recorded in related information under item 8 (Equipment information) (see 4.8).

Example:

The 12th digital leased circuit between users' premises in Athens and Reims which is connected to transmission station TS2 in Athens and permanently switched in the international exchange IP2 in Reims is designated:

Athinai/TS2–Reims/IP2 NP12.

(Recording of suffixes is not mandatory.)

3.2.16 Digital leased circuits connecting three or more locations

Various types and configurations of multiterminals circuits fall into this category. Each section of the circuit should have a unique designation. A section is any part of the circuit which connects a branching point to either a customer terminal or another branching point. (See also Recommendation M.1055 [4].)

International sections should use the designation described below.

The terminal points of each section are arranged in alphabetical order.

The function code is formed by adding the letter M to the function code recommended in 3.2.15, i.e. the function code is: NPM.

The association between sections should be recorded in the related information of each section under item 7 (Association) (see 4.7).

Wholly national sections with national designations may be included if bilaterally agreed.

Superseded by a more recent version

Example:

In an international digital multiterminal leased circuit connecting Oslo, London, Paris, Rome and Amsterdam, the international section between Oslo and London (being the first NPM circuit on this relation) is designated:

London–Oslo NPM1.

3.3 Fixed (non-switched) public circuits

3.3.1 General

The designation format is according to 3.1. Possible function codes are:

- R for a unidirectional sound-programme circuit;
- RR for a reversible sound-programme circuit;
- RK for telephone type circuits for narrow band sound-programme transmission;
- V for a unidirectional television circuit;
- VV for a reversible television circuit;
- F for a phototelegraphy or facsimile circuit;
- T for circuits providing voice-frequency telegraph links;
- TD for circuits providing TDM-telegraph systems;
- D for data transmission circuits;
- DL for circuits providing transfer link for common channel signalling systems.

NOTE – Information on whether a sound-programme circuit together with a second sound-programme circuit form a stereophonic pair will be recorded in the related information under the item 7 (Association) (see 4.7).

3.3.2 Circuits used for sound-programme transmission

3.3.2.1 Circuits used for unidirectional sound-programme transmission

The terminations of the circuit are arranged in the order corresponding to the direction of transmission (instead of alphabetically, if this is different).

The function code is: R.

Serial numbering: Circuits which transmit in the direction corresponding to the alphabetical order of the terminals should have odd serial numbers. Circuits which transmit in the direction corresponding to the inverse alphabetical order of the terminals should have even serial numbers.

Example:

The 1st circuit transmitting in the direction Wellington (New Zealand) to Montreal is designated:
WellingtonNZL–Montreal R2.

3.3.2.2 Circuits used for reversible sound-programme transmission

The terminations of the circuit are arranged in alphabetical order.

The function code is: RR.

Example:

The 1st circuit with reversible sound-programme transmission between Montreal and Wellington (New Zealand) is designated:
Montreal–WellingtonNZL RR1.

Superseded by a more recent version

3.3.2.3 Telephone-type circuits used for narrow-band sound-programme transmission

In the traffic relation, the terminals of the circuit are arranged in the order corresponding to the direction of operation (instead of alphabetically, if this is different).

The function code is: RK.

Serial numbering: Circuits which transmit in the direction corresponding to the alphabetical order of the terminals should have odd serial numbers. Circuits which transmit in the direction corresponding to the inverse alphabetical order of the terminals should have even serial numbers.

Example:

The 1st telephone-type circuit set up for the narrow-band sound-programme transmission in the direction from Milano to Madrid is designated:

Milano–Madrid RK2.

3.3.3 Circuits used for television transmission

3.3.3.1 Circuits used for unidirectional television transmission

In the traffic relation, the terminations of the circuit are arranged in the order corresponding to the direction of transmission (instead of alphabetically, if this is different).

The function code is: V.

Serial numbering: Circuits which transmit in the direction corresponding to the alphabetical order of the terminals should have odd serial numbers. Circuits which transmit in the direction corresponding to the inverse alphabetical order of the terminals should have even serial numbers.

Example:

The 1st unidirectional television circuit transmitting in the direction Paris to Helsinki is designated:

Paris–Helsinki V2.

3.3.3.2 Circuits used for reversible television transmission

The terminations of the circuit are arranged in alphabetical order.

The function code is: VV.

Example:

The 1st reversible television transmission circuit between Tokyo TS1 and New Delhi is designated:

New Delhi–Tokyo/TS1 VV1.

3.3.4 Circuits for digital audio and video transmission

These circuits are designated according to the data transmission system, see clause 11.

3.3.5 Telephone-type circuits used for phototelegraphy or facsimile

Circuits used for phototelegraphy or facsimile which are different from normal telephone circuits will have the function code: F.

The terminal points of the circuit are arranged in alphabetical order.

If normal telephone circuits are used, they are designated accordingly. Information about the usage may be recorded in the related information under item 9 (Use) (see 4.9).

Superseded by a more recent version

Example:

The first circuit for phototelegraphy between Koebenhavn and Tokyo:
Koebenhavn–Tokyo F1.

3.3.6 Telephone-type circuits used to provide voice-frequency telegraph links

The terminal points of the circuit are arranged in alphabetical order.

The function code is: T.

Example:

The 1st circuit to provide a voice-frequency telegraph link between Koebenhavn 1 and Montreal 1TE is designated:

Koebenhavn/1–Montreal/1TE T1.

(Suffixes are optional.)

A reserve T-circuit is designated according to its present function. Information concerning the nature of the reserve T-circuit is found in the related information under item 7 (Association) (see 4.7).

3.3.7 Telephone-type circuits used to provide TDM (Time Division Multiplex) telegraph systems

The terminal points of the circuit are arranged in alphabetical order.

The function code is: TD.

Example:

The first circuit to provide a TDM-telegraph system between London Keybridge and Montreal 1TE:
London/KB–Montreal/1TE TD1.

(Suffixes are optional.)

A reserve TD-circuit is designated according to its present function. Information concerning the nature of the reserve TD-circuit is found in the related information under item 7 (Association) (see 4.7).

3.3.8 Telephone-type circuits used for data transmission

The terminal points of the circuit are arranged in alphabetical order.

The function code is: D.

Example:

The 1st circuit used for data transmission between Frankfurt 1 and Toronto 1TE is designated:
Frankfurt/1–Toronto/1TE D1.

(Suffixes are optional.)

3.3.9 Telephone-type circuits used as transfer links for common channel Signalling Systems No. 6 and No. 7

The terminal points of the circuit are arranged in alphabetical order.

The function code is: DL.

Superseded by a more recent version

Example:

The first data link used for common channel signalling between Sacramento 4ESS and Tokyo Shinjuku is designated:

Sacramento/4ES–Tokyo/SJK DL1.

(Suffixes are optional.)

3.4 Related information

The additional information on fixed circuits is covered by the following items:

- 1) urgency for restoration;
- 2) terminal countries;
- 3) Administrations' carriers, or broadcasting companies' names;
- 4) control and sub-control station(s);
- 5) fault report points;
- 6) routing;
- 7) association;
- 8) equipment information;
- 9) use;
- 10) transmission medium information;
- 11) composition of transmission;
- 12) bandwidth or bit rate;
- 13) signalling type;
- 14) applicable CCITT/ITU-T Recommendations.

The various items will be dealt with in clause 4.

4 Related information for international fixed circuits

The following subclauses explain the items of related information concerned with international fixed circuits. A full example for the designation information of an international leased analogue circuit is given in A.2.

4.1 Urgency for restoration [item 1)]

This item supplies information on the urgency of restoration of the circuit based upon bilateral agreement between the terminal Administrations.

Format:

1. xxx . . . xx; (maximum 10 characters)

Illustration:

- a) if the priority is top: 1;
if the priority is second: 2;
if the priority is third: 3; or
- b) if repair is required within e.g. 24 hours: ≤ 24 h; or
- c) if no urgency has to be indicated: –;

Superseded by a more recent version

NOTE – In the case of a digital leased circuit, the priority or urgency may be decided upon by taking into account the bit rate of the circuit.

4.2 Terminal countries [item 2]

This item presents the countries in which the circuit is terminating.

Format:

2. XXX, YYY; (3 characters for each)

Specification:

XXX: code for country of town A

YYY: code for country of town B

NOTE – The codes are according to the ISO Standard 3166 [2].

Example:

For the circuit Paris–WellingtonNZL P1:

2. FRA, NZL;

4.3 Names of Administrations, carriers or broadcasting companies [item 3]

This item records the names of the Administrations or carriers which operate the circuit or, in the case of sound-programme and television circuits, the name of the broadcasting company. The applicable carrier codes can be selected from the ITU-T "List of International Carrier Codes" [22].

Format:

3. YYYYYY, ZZZZZZ; (maximum 6 characters for each)

Specification:

YYYYYY: code for company operating in town A

XXXXXX: code for company operating in town B

Example:

For the circuit Bern/IRS–NewYork/IRC TP1 operated by Radio Suisse and RCA:

3. RS, RCA;

4.4 Control station [sub-control station(s)] [item 4]

This item lists the appointed control station and sub-control stations (according to Recommendations M.80 [15] and M.90 [16] or M.1012 [5] and M.1013 [6] for leased circuits). Further details about the stations can be found in the list of contact points (Recommendation M.1510 [17]).

Example:

4. CS: designation of control station,
SCS1: designation of sub-control station,
SCS2: designation of sub-control station,
⋮ ⋮
SCSn: designation of sub-control station.

Superseded by a more recent version

Specification:

- CS: designation of the control station,
- SCS1: designation of the terminal sub-control station,
- SCS2 to SCSn: if applicable, other sub-control stations have to be placed in the geographical order according to the traffic relation.

Example:

For the circuit London/KB–Paris/ARC RP1 where Paris Archives is the control station and London Keybridge is the sub-control station:

- 4. CS: Paris/ARC,
- SCS1: London/KB.

4.5 Fault report points [item 5]

This item presents the names of both fault report points on the circuit. Further information about the fault report points can be found in the list of contact points (Recommendation M.1510 [17]).

Format:

- 5. Designation of fault report point, designation of fault report point.

Specification:

The first fault report point is that of the country of town A.

The second fault report point is that of the country of town B.

Example:

The fault report points for the circuit Athinai–Roma DP3:

- 5. Athinai, Roma/TS1.

4.6 Routing [item 6]

This item shows the international primary group(s) or primary block(s) and the channel number(s) which carry the circuit (see Notes 1 and 2). If there are more than one, the groups or blocks appear in the geographical order from town A to town B.

Format:

- 6. Designation of an international primary group (Note 1) or primary block/channel number, designation of a primary group of block/channel number, . . ., designation of a primary group or block/channel number;

Example 1:

For the circuit from London Mollison to Paris Archives DP7:

- 6. London–Paris 1204/4;

Example 2:

For the wide-band circuit Frankfurt–London DP5:

- 6. Amsterdam–Frankfurt 6005/2, Amsterdam–London 6002/3;

NOTE 1 – In the case where a leased circuit consists of a group or block, the primary groups or blocks are to be replaced by the next higher groups or blocks. In this case, the channel numbers are to be replaced by the group numbers.

Superseded by a more recent version

NOTE 2 – Primary groups or blocks can be unidirectional as well. Two consecutive unidirectional groups or blocks are separated by a + sign instead of a comma.

4.7 Association [item 7)]

This item informs whether there are associated circuits and if so, of what nature.

Format:

7. Association code: Designation(s) of associated circuit(s);

Specification:

If the circuit *has* a reserve circuit, the association code is: S. This is followed by the function code and the serial number of the principal circuit.

NOTE – In this case, the designation of the associated circuit may be replaced by the designation of a free time slot or a free channel.

If the circuit is a reserve circuit, the association code is: function code followed by S and this is the serial number of the reserve circuit.

If a circuit must have diverse routing with respect to another circuit, the association code is: DVR. This is followed by the designation of the other circuit.

If the circuit is one of a stereophonic pair, the other circuit will appear in this item. Association code is: H followed by a 2-digit serial number indicating the number of the stereophonic pair. This is followed by the function code and the serial number of actual circuit.

If the circuit belongs to a multiterminal leased circuit, the association code is: PM, DPM, etc. (see 3.2.12 and 3.2.16) and this is followed by the serial number of the circuit.

Example 1:

7. ST1: Roma/AS1–Zuerich/SEL Z13;

which indicates that the reserve circuit for the principal circuit T1 is Roma/AS1–Zuerich/SEL Z13.

In the case of a free channel in the group Roma–Zuerich 1205:

7. ST1: Roma–Zuerich 1205/6;

Example 2:

The two leased circuits Kolding–Lausanne DP and Geneve–Koebenhavn DP 18 must have diverse routing.

For the first circuit Kolding–Lausanne DP7:

7. DVR: Geneve–Koebenhavn DP18;

Example 3:

If the circuit London/KB–Paris/ARC R1 is bearing one channel of the second stereophonic pair from London to Paris, and London/KB–Paris/ARC R5 bearing the other channel of this pair:

7. H02R1: London/KB–Paris/ARC R5;

which indicates that circuit R1, being one of the stereophonic pair number 2, has as the other circuit of this pair: London/KB–Paris/ARC R5.

Superseded by a more recent version

Example 4:

If the circuit Bruxelles–Edinburgh PM1 is a part of an international multiterminal telephone circuit connecting Bruxelles and Paris (being the 7th PM-circuit on that relation) with branches from Bruxelles to Edinburgh and to Aachen (being the 2nd PM-circuit on that relation) and with an extension from Paris to Marseilles, then for the circuit Bruxelles–Edinburgh PM1:

7. PM1: Aachen–Bruxelles PM2, Bruxelles–Paris PM7;

NOTE – The international branches may appear in any order. National branches may be added after bilateral agreement.

4.8 Equipment information [item 8]

This item records any equipment in the circuit which requires special maintenance attention.

Format:

8. XX, XX, XX, XX, XX;

Specification:

If the circuit has been routed via digital circuit multiplication equipment: AM

If the circuit has been routed via digital circuit multiplication equipment

- using reduced bit rate encoding: RB
- using speech interpolation: SI

If the circuit has a compandor: CO

If the circuit consists of a semi-permanent switched connection: SP

NOTE – If there is a need to record additional special equipment, additional codes can be used by bilateral agreement between the Administrations. The codes must be unique and shall have two characters.

4.9 Use [item 9]

This item identifies for what purpose the circuit is used (if this is known by the Administration and of use for maintenance).

Format:

9. XXX . . XX; (maximum 7 characters)

Specification:

XX . . XX allows the record of the usage of the circuit. A comma may be included anywhere to separate two or more codes, in case the circuit has two or more simultaneous usages.

If the circuit has been provided with circuit multiplication equipment at renters' premises with connection channels: CC.

If the circuit is used for the COMFAX service: CFX.

4.10 Transmission medium information [item 10]

This item identifies whether a particular transmission medium is required in the routing of the circuit.

Format:

10. ST: XX . . . XX; or 10. NS: XX . . . XX; or 10. –; (XX . . . XX maximum 10 characters)

Superseded by a more recent version

Specification:

If the circuit has to be routed via satellite: ST followed by the designation of the satellite.

If the circuit must not be routed via satellite: NS followed by the designation of the terrestrial transmission medium.

If there is no transmission medium requirement: –.

Example:

For the circuit London–Paris DP3 that has to be routed via satellite Telecom 1:

10. ST: Tel 1.

4.11 Composition of the transmission [item 11]

This item shows the type of transmission on the circuit.

Format:

11. A; N; or C;

Specification:

If the transmission is analogue: A

If the transmission is digital: N

If the transmission is mixed analogue/digital: C

4.12 Bandwidth or bit rate [item 12]

This item shows the bandwidth (in the case of an analogue circuit or mixed circuit) or the bit rate (in the case of a digital circuit).

Format:

12. xxxx.x Hz; or kHz; or MHz; bit/s; or kbit/s; or Mbit/s;

Rules for the notation of the figures:

Leading zeros may be omitted, and if the decimal is a zero, this decimal and the decimal point may also be omitted.

If the figure is up to 999, use Hz, bit/s.

If the figure is between 1000 and 9 999 999, use kHz, kbit/s.

If the figure is 10 000 000 or more, use MHz, Mbit/s.

Specification:

If the circuit is analogue or mixed analogue/digital: the bandwidth Hz, kHz, MHz.

If the circuit is digital: the bit rate in bit/s, kbit/s, Mbit/s.

Example:

For the circuit Bordeaux–Darmstadt NP7 with a bit rate of 64 kbit/s:

12. 64 kbit/s.

Superseded by a more recent version

4.13 Signalling type [item 13]

This item presents the signalling type that applies to the circuit (reference is made to Recommendations M.1045 [7] and Q.8 [8]).

Format:

13. xxxxxxx; (maximum 7 characters)

Specification:

If the signalling is of the type xxxx Hz/xx Hz: xxxx/xx. Otherwise, the characters can be used on the basis of bilateral agreement between the two terminal Administrations.

Example:

For a circuit with in-band signalling 1000 Hz/20 Hz:

13. 1000/20.

4.14 Applicable CCITT/ITU-T Recommendations [item 14]

This item records the CCITT/ITU-T Recommendation(s) applied as regards the parameters of the circuit.

Format:

14. Rec. X.xxxx, Rec. Y.yyyy; or 14. Rec. X.xxxx; or 14. –;

Specification:

The number of Recommendations to be recorded (2, 1, or 0) is dependent on the need.

Example 1:

If the circuit is an analogue leased line:

14. Rec. M.1020;

Example 2:

If the circuit is used for the COMFAX (CFX) service:

14. Rec. F.162, Rec. F.163;

5 Designations of international groups, supergroups, etc. (bidirectional and unidirectional)

5.1 General

The format of the designation of groups, etc. is shown in Table 4.

Superseded by a more recent version

Table 4/M.1400

Format of designation	Town A	/	Transmission station suffix (optional)	–	Town B	/	Transmission station suffix (optional)		Function code	Serial number
Signs	Characters	Slash	Letters/digits	Hyphen	Characters	Slash	Letters/digits	Space	Letters/digits	Digits
Number of characters	≤ 12	1	≤ 3	1	≤ 12	1	≤ 3	1	1 to 6	2 to 3
									↑ No space	

The elements of the format are as follows:

a) *Traffic relation*

Groups etc. are indicated by the names of the towns where the groups, etc. terminate. For the spelling, see 1.1. The town names are arranged in alphabetical order. For multiple destination unidirectional groups, the name of town B is replaced by (MU) (see 5.3.1). In the case that a town name exceeds the maximum length of 12 characters, the responsible Administration should supply a suitable abbreviation that must be unique (see 0.1).

The transmission station suffix (maximum 3 characters), although optional, is recommended for all new and modified records, to identify the terminal point of the international carrier providing the group, when there is more than one carrier operating in the town. The necessity for a suffix and its form should be decided by the Administration operating the circuit in the town concerned.

b) *Function code*

This code consists of the nominal number of channels in the group (see Note). In the case of a unidirectional single destination group, the number is preceded by (U) (see 5.3.2).

NOTE – Where group, supergroup, etc., links are directly interfaced by analogue to digital conversion equipment, the number of channels is followed by the letter C (see clause 10).

c) *Serial numbering*

The numbering is on a town-to-town basis with an exception for the case where the suffix is used. The numbering for that case is made on a transmission station to transmission station basis.

The numbering of a group, supergroup, etc., is applied between the point where the group, etc., is assembled to the point where it is broken down, independently of the position it occupies in the band of line frequencies.

If the number is less than 10, it is preceded by a zero.

5.2 Bidirectional groups, etc.

5.2.1 Group

The function code is a number that indicates the nominal number of channels in the group, as follows:

8 for 8-channel groups,

12 for 12-channel groups,

16 for 16-channel groups.

Superseded by a more recent version

Example:

The third 12-channel group between Moskva and New York is designated:
Moskva–New York 1203.

5.2.2 Supergroup

The function code is a number that indicates the nominal number of channels in the supergroup, as follows:

60 for 60-channel supergroups.

80 for 80-channel supergroups.

Example:

The first 60-channel supergroup between London and Amsterdam is designated:
Amsterdam–London 6001.

5.2.3 Mastergroup

The function code is: 300.

Example:

The first mastergroup between Bruxelles and London is designated:
Bruxelles–London 30001.

5.2.4 Supermastergroup

The function code is: 900.

Example:

The tenth supergroup between Amsterdam and Paris is designated:
Amsterdam–Paris 90010.

5.2.5 Use of the groups, etc.

This information will be contained in related information under item 9 (Use) (see 7.9). If groups are used for private purposes, see 3.2.13.

5.2.6 Restoration groups and supergroups

Groups and supergroups set up on restoration groups and supergroups, or on spare groups and supergroups for restoration purposes, will receive a serial number from the 800 series, in descending order and starting from 899.

Restoration groups: 8899, 8898, 8897, etc.,
 12899, 12898, 12897, etc., or
 16899, 16898, 16897, etc.,
 as appropriate.

Restoration supergroups: 60899, 60898, 60897, etc.

Example 1:

The second 12-channel restoration group between London and Sydney is designated:
London–Sydney 12898.

Superseded by a more recent version

Example 2:

The first restoration supergroup between Amsterdam and Bruxelles is designated:
Amsterdam–Bruxelles 60899.

5.3 Unidirectional groups and supergroups

5.3.1 Multiple destination unidirectional groups and supergroups

The unidirectional route will be designated by the name of the sending terminal station (in the general format: town A) followed by a hyphen, and the letters MU (multiple destination unidirectional) in parentheses replace town B. This will be followed by the function code and serial number of the group or supergroup.

Example 1:

The first multiple destination unidirectional supergroup from London (to, for example Bogota, Lusaka and Montreal) is designated:

London–(MU) 6001.

The next such supergroup from the same point of origin to any destination would take the next number in the series, e.g. the second supergroup from London is designated:

London–(MU) 6002.

This supergroup might go, for example, to Tokyo, Hawaii and Melbourne.

Example 2:

The first supergroup from Montreal (to, for example, London, Lusaka and Paris) is designated:

Montreal–(MU) 6001.

NOTE – Groups and supergroups routed via a multiple-access system may be provided for exclusive use between two terminal stations only, in which case the normal designations given above in this Recommendation will apply.

5.3.2 Single destination unidirectional groups and supergroups

The unidirectional route will be designated by the name of the sending terminal station (in the general format: town A) followed by a hyphen and the name of the receiving terminal station (town B). The function code consists of the letter U (unidirectional) in parentheses and the nominal number of channels of the group or supergroup.

Example:

A unidirectional group transmitting in the direction from Paris to Etam, which, in the reverse direction of transmission is assigned to a multiple destination unidirectional (MU) group from Etam to Paris and Rio de Janeiro, would be designated as:

Paris–Etam (U) 1201.

The next group between these locations, Paris and Etam, if bidirectional, would be designated in the normal manner as:

Etam–Paris 1202.

NOTE – Groups and supergroups routed via a multiple-access system may be provided on a bidirectional basis for exclusive use between two terminal stations only, and in this case the normal designations given above in this Recommendation will apply.

Superseded by a more recent version

5.4 Related information

The additional information on groups etc., is covered by the following items:

- 1) urgency for restoration;
- 2) terminal countries;
- 3) Administrations', carriers' or broadcasting companies' names;
- 4) control and sub-control station(s);
- 5) fault report points;
- 6) routing;
- 7) association;
- 8) equipment information;
- 9) use;
- 10) transmission medium information;
- 11) (unassigned item, use: "–");
- 12) bandwidth;
- 13) occupancy.

The various items will be dealt with in clause 7.

6 Designations of international group links, supergroup links and line links

6.1 Group and supergroup links

Group links and supergroup links are designated according to the general format for groups (see 5.1). In practice, it may be that terminal equipment is not connected to a group link or supergroup link. Nevertheless, for designation purposes, the link will be numbered as though terminal equipment were connected.

6.1.1 Conventional links not connected to their terminal equipment

Such links are included in the normal numbering sequence of groups and supergroups and are not given a separate numbering sequence.

When a group link or supergroup link is used only part time with terminal translating equipment (to provide a conventional group or supergroup) it will be designated in the normal way. The part time condition of the group link has to be indicated in related information under item 9 (Use) (see 7.9).

Example:

The group link between Amsterdam and London set up following 5 groups already in service, is designated:

Amsterdam–London 1206.

6.1.2 Restoration links

Group links and supergroup links nominated for restoration purposes will receive a serial number from the 800-series in ascending order and starting from 801.

Restoration group links: 12801, 12802, 12803, etc.,

Restoration supergroup links: 60801, 60802, 60803, etc.

Superseded by a more recent version

Example:

The second restoration group link between Hong Kong and Sydney is designated:

Hong Kong–Sydney 12802.

NOTE – The first two digits (e.g. 12) in the designation of a restoration group link do not necessarily indicate the number of channels in the group which is set up via the link. For example, a restoration group link London–Montreal 12801 might be used to restore the group London–Montreal 1605.

6.2 Line links

The format of the designation of line links is shown in Table 5.

Table 5/M.1400

Format of designation	Town A	/	Transmission station suffix (optional)	–	Town B	/	Transmission station suffix (optional)		Function code	Serial number
Signs	Characters	Slash	Letters/digits	Hyphen	Characters	Slash	Letters/digits	Space	Letters/digits	Digits
Number of characters	≤ 12	1	≤ 3	1	≤ 12	1	≤ 3	1	3 to 5	2
									↑	No space

The elements of the format are as follows:

- a) *Traffic relation*
The two terminals are arranged in alphabetical order. For the use of the suffix, see 5.1.
- b) *Function code*
This code consists of a number indicating the nominal telephone channel transmission capacity followed by the letter A.
- c) *Serial number*
This is a two-digit number.

Example 1:

The first 1840 telephone channel capacity line link between Beaver Harbour and Widemouth is designated:

Beaver Harbo–Widemouth 1840A01.

Example 2:

The first 432 telephone channels capacity line link between Etam and Pleumeur-Bodou is designated:

Etam–Pleumeur-Bod 432A01.

NOTE – Line links are sometimes characterized by having channel capacities not in accordance with normal group, supergroup, etc., alignments. Examples of these non-standard capacities may often be found in submarine cable or satellite line links. These links will be numbered in accordance with the nominal channel capacity of the link.

Superseded by a more recent version

6.3 Related information

The additional information on group links, supergroup links and line links is covered by the following items:

- 1) urgency for restoration;
- 2) terminal countries;
- 3) Administrations', carriers', or broadcasting companies' names;
- 4) control and sub-control station(s);
- 5) fault report points;
- 6) routing;
- 7) association;
- 8) equipment information;
- 9) use;
- 10) transmission medium information;
- 11) (unassigned item, use: "-;");
- 12) bandwidth;
- 13) occupancy (this item is not in use for group links and line links).

The various items will be dealt with in clause 7.

7 Related information for international groups, group links and line links

The following subclauses explain the items of related information concerned with international groups, group links, line links, etc. Full examples for the designation information of an international group and an international group link is given in A.3.

7.1 Urgency for restoration [item 1)]

This item supplies information on the urgency of restoration of the group/group link based upon bilateral agreement between the terminal Administrations.

Format:

1. xxx xx; (maximum 10 characters)

Illustration:

- a) if the priority is top: 1;
if the priority is second: 2;
if the priority is third: 3; or
- b) if repair is required within e.g. 24 hours: ≤ 24 h; or
- c) if no urgency has to be indicated: –;

Example:

If the group Bonn–Paris 1201 needs top priority restoration:

1. 1;

Superseded by a more recent version

7.2 Terminal countries [item 2]

This item presents the countries in which the group/group link is terminating.

Format:

2. XXX, YYY; or XXX; (3 characters for each)

Specification:

XXX: code for country of town A

YYY: code for country of town B

In the case of a multiple destination unidirectional group (MU), only XXX applies.

Example 1:

For the group Beograd–Roma 1201:

2. YUG, ITA;

Example 2:

For the multiple destination group Toronto–(MU) 1202:

2. CAN;

NOTE – The codes are according to ISO Standard 3166 [2].

7.3 Names of Administrations, carriers or broadcasting companies [item 3]

This item records the names of the carriers, etc., which operate the group/group link. The applicable carrier codes can be selected from the ITU-T "List of International Carrier Codes" [22].

Format:

3. XXXXXX, YYYYYY; or XXXXXX; (maximum 6 characters for each)

Specification:

XXXXXX: name of company in town A

YYYYYY: name of company in town B

In the case of an unidirectional multiple destination, only XXXXXX applies.

Example 1:

For the supergroup Amsterdam–London 6002:

3. TCOMNL, BTI;

Example 2:

For the multiple destination group Hong Kong–(MU) 1201:

3. HKGTEL;

7.4 Control station [sub-control station(s) [item 4]

This item lists the appointed control station and sub-control stations (according to Recommendations M.80 [15] and M.90 [16]). Further details about the stations can be found in the list of contact point (Recommendation M.1510 [17]).

Superseded by a more recent version

Format:

- 4. CS: designation of control station,
- SCS1: designation of sub-control station,
- SCS2: designation of sub-control station,
- ⋮ ⋮
- SCSn: designation of sub-control station.

or in the case of a multiple destination unidirectional group:

- 4. CS: designation of control station,

Specification:

- CS: designation of the control station,
- SCS1: designation of the terminal sub-control station,
- SCS2 to SCSn: if applicable, other sub-control stations have to be placed in the geographical order according to the traffic relation.

In the case of a multiple destination unidirectional group, only CS applies.

Example 1:

For a group Helsinki–Paris 1201 where the control station is Helsinki TM1 and the sub-control station is Paris Archives:

- 4. CS: Helsinki/TM1,
- SCS1: Paris/ARC;

Example 2:

For the multiple destination unidirectional group Wien–(MU) 1201:

- 4. CS: Wien/ARS;

7.5 Fault report points [item 5]

This item presents the names of both fault report points on the group/group link (according to Recommendation M.2130 [18]). Further details about the fault report points can be found in the list of contact points (Recommendation M.1510 [17]).

Format:

- 5. Designation of fault report point, designation of fault report point;
- or
- 5. Designation of fault report point;

Specification:

The first fault report point is that of the country of town A. The second fault report point is that of the country of town B. In the case of a multiple destination unidirectional group, there is only one fault report point under item 5.

Example 1:

For the group Moskva–Paris 1201:

- 5. Moskva/MNA, Paris/ARC;

Superseded by a more recent version

Example 2:

For the multiple destination unidirectional group Caracas–(MU) 1201:

5. Caracas/TS1;

7.6 Routing [item 6)]

This item records the next higher group within the multiplex hierarchy on which the group/group link has been routed and the position number, or in the case of the highest multiplex level, the transmission media on which the group/group link has been routed.

Format:

6. Designation of an international group/position number or designation of transmission medium, designation of an international group/position number or designation of transmission medium, . . ., designation of an international group/position number or designation of transmission medium;

NOTE – Two consecutive unidirectional groups are separated by a + sign instead of a comma.

Specification:

The designation of an international group refers to the next higher level in the multiplex hierarchy. If there are more than one, the groups are noted in geographical order from town A to town B.

The designation of the transmission medium refers to the transmission medium leaving the country of town A and to the transmission medium entering the country of town B, respectively.

As no CCITT/ITU-T designations of transmission media are provided for the time being, the terminal countries should provide designations or agree on designations.

If there is only one transmission medium, the designation of this medium applies.

Example 1:

A group Alger–London 1201 has been routed internationally as follows:

6. Alger–Paris 6002/2, London–Paris 6040/5;

Example 2:

A supermaster group Barcelona–Perpignan 90001 has been routed as follows:

6. Gerona–Perpignan 1800A08;

Example 3:

A group Caracas–Paris 1201 has been routed as follows:

6. Caracas–Paris 6001/2+Caracas–(MU) 6002/3;

7.7 Association [item 7)]

This item informs whether there are associated group/group links and if so, of which nature.

Format:

7. Association code: designation(s) of the associated group(s) or group link(s);

Specification:

If the group *has* a reserve group, the association code is: S followed by the function code and the serial number of the group.

Superseded by a more recent version

If the group *is* a reserve group, the association code is: function code followed by S and the serial number of the reserve group.

The same applies for group links.

Example:

If the normal group is Bruxelles–Luxembourg 1215 and if the group Bruxelles–Luxembourg 12899 serves as a restoration group for the group Bruxelles–Luxembourg 1215:

7. S1215: Bruxelles–Luxembourg 12899;

For the group Bruxelles–Luxembourg 12899 there has to be recorded under item 7:

7. 12S899: Bruxelles–Luxembourg 1215;

7.8 Equipment information [item 8]

This item records information on equipment in the group/group link which requires special maintenance attention.

Format:

8. XX, XX, XX, XX;

Specification:

If the group is carrying companded circuits: CO

If a group has been routed via TDMA: TD

If there is no special equipment: –

NOTE – If there is a need to record any additional equipment information, the free codeplaces are available for that purpose. The codes to be used must consist of two characters, be unique and can be chosen by bilateral agreement between Administrations.

Example:

If a group Genève–Mexico 1210 is carrying companded circuits:

8. CO;

7.9 Use [item 9]

This item identifies for what purpose the group/group link is used (if this is known by the Administration and of use for maintenance).

Format:

9. XXXXXX; (maximum of 6 characters)

Specification:

XXXXXX refers to (among others) the designatory letters Z, B, D, X, DP, RP, VP, etc., as explained in clauses 1 and 3. If no other information available, the sign – is used.

Example:

If the group London–Melbourne 1212 is dedicated to DP-circuits:

9. DP;

7.10 Transmission medium information [item 10]

This item identifies whether a satellite is involved in the routing.

Superseded by a more recent version

Format:

10. ST; or –;

Specification:

If the group/group link has been routed via satellite: ST

If the group/group link has not been routed via satellite: –

Example:

If the group Caracas–Madrid 1203 has been routed via satellite:

10. ST;

7.11 End-to-end information (for mixed analogue/digital routes only) [item 11]

This item provides information on the destinations of the traffic carried by the group.

Format:

11. X . . . X, Y . . . Y; (maximum 12 characters each) or –;

Specification:

X . . . X and Y . . . Y are the names of a town and refer to the destinations of the traffic on the group. The destinations are placed according to the order of towns in the traffic relation.

If the group has a multiple destination, one town name is replaced by the code: M.

If the group is within an analogue environment, X . . . X, Y . . . Y is replaced by the sign –.

Example:

If the group Athinai–Paris 60C11 carries traffic from Bruxelles to Sofia:

11. Sofia, Bruxelles;

7.12 Bandwidth [item 12]

This item shows the bandwidth of the group/group link.

Format:

12. xxxx kHz or MHz or GHz

Rules for the notation of the bandwidth figures:

No leading zeros required.

If the figure is between 10 000 and 9 999 999, use kHz.

If the figure is between 10 000 000 and 9 999 999 999, use MHz.

If the figure is 10 000 000 000 or more, use GHz.

Example:

A group Bangkok–New Delhi 1201:

12. 48 kHz;

7.13 Occupancy (for groups/supergroups, etc., and for line links) [item 13]

This item lists the occupancy of the group expressed by the next lower group and/or circuits which have been routed in the group.

Superseded by a more recent version

Format in the case of a group (lowest level):

13. Position number: designation of the circuit, or the sign –,

∴ ∴

Position number: designation of the circuit, or the sign –;

Format in the case of a supergroup or higher level group:

13. Position number: designation of a group, of a leased circuit, or the sign –,

∴ ∴

Position number: designation of a group of a leased circuit, or the sign –;

Specification:

If the position number is occupied by a next lower group: designation of this group.

If the position number is occupied by a leased circuit (with a bandwidth corresponding to the bandwidth of the next lower multiplex level, e.g. see 3.2.13): designation of this leased circuit.

If the position number is not in use: –

Example:

For a supergroup Athinai–Paris 6002:

13. 01: Beyrouth–Paris 1209,

02: London–Sofia 1202,

03: Athinai–Paris 1205,

04: Athinai–Rotterdam 1202,

05: Athinai–Paris DP4;

8 Designations of international digital blocks (bidirectional and unidirectional)

8.1 General

This subclause refers to blocks which are part of the digital multiplex hierarchy and which are formatted according to Recommendations G.734, G.736, G.742, G.743, G.745, G.751, G.752, G.753 and G.754 [10]. The bit rates for these blocks, defined in Recommendation G.702, are: 1544 kbit/s, 2048 kbit/s, 6312 kbit/s, 8448 kbit/s, 32 064 kbit/s, 34 368 kbit/s, 44 736 kbit/s, 97 728 kbit/s and 139 264 kbit/s. All other blocks are designated according to clause 11.

An international digital block exists between two terminal points when it is possible to operate and monitor the block at both terminal points, without any other intermediate point where the original transmission structure ceases or is in some way modified.

When in the interconnection route between two terminal transmission points an intermediate point is present where the digital transmission structure is demodulated, the route is split in two separate parts. Therefore, all present possible digital blocks exist only between the original route end points and that intermediate point and then have to be designated separately (according to the above rule).

Basically, two different multiplex configurations apply:

Symmetrical: Both terminal points have the same multiplexing configuration. The digital blocks existing (i.e. those effectively operated and monitored) are designated as described in 8.2.1 (according to the above rule).

Superseded by a more recent version

Asymmetrical: One of the two terminal points has a different multiplexing configuration from the one used by the other point. The digital blocks existing (i.e. those effectively operated and monitored) are designated as described in 8.2.2.

The format of the designation of digital blocks is shown in Table 6.

Table 6/M.1400

Format of designation	Town A	/	Suffix for transmission station or international exchange (optional)	–	Town B	/	Suffix for transmission station or international exchange (optional)	Space	Function code	Serial number
Signs	Characters	Slash	Letters/digits	Hyphen	Characters	Slash	Letters/digits	Space	Letters/digits	Digits
Number of characters	≤ 12	1	≤ 3	1	≤ 12	1	≤ 3	1	3 to 6	≤ 4
									↑ No space	

The elements of the format are as follows:

a) *Traffic relation*

Town A and town B, possibly with a suffix for the transmission station or international exchange, indicate the terminal points of the block. For the spelling, see 1.1. If a town name exceeds the maximum length of 12 characters, the Administration should apply a suitable abbreviation which must be unique (see 0.1). The town names are arranged in alphabetical order.

The suffix for the transmission station or international exchange (maximum 3 characters), although optional, is recommended for all new and modified records, to identify the terminal point of the international carrier providing the block, when there is more than one carrier operating in the same town. The necessity for a suffix and its form should be decided by the Administration operating the digital block in the town concerned.

In the case of a multiple destination unidirectional block, town B is replaced by (MU) (see 8.4).

b) *Function code*

This code consists of a number indicating the nominal number of channels in the block followed by the letter N. The function codes, for blocks formatted according to Recommendations G.734, G.736, G.742, G.743, G.745, G.751, G.752, G.753 and G.754 [10], are: 24N, 30N, 96N, 120N, 480N, 672N, 1440N and 1920N.

For blocks in a mixed analogue/digital environment, see 10.1.2. (In this case, 6 characters or less are required.)

c) *Serial number*

This is a 1- to 4-digit number which counts the number of blocks with the same traffic relation and the same function code.

Superseded by a more recent version

8.2 Bidirectional digital blocks

8.2.1 Symmetrical configuration

As stated in 8.1, symmetric configuration means the same multiplexing configuration is present in both terminal transmission stations. The configuration in use defines the digital blocks to be designated.

Example 1:

In London and Paris, the same multiplexer configuration is being applied with a 34-Mbit/s supplying 4×8 -Mbit/s digital block. Then, an 8-Mbit/s block exists. The fourth secondary order block between London and Paris is designated:

London–Paris 120N4.

Example 2:

The tenth primary order block between New York and Tokyo is designated:

New York–Tokyo 24N10.

8.2.2 Asymmetrical configuration

As stated in 8.1, asymmetrical configuration means that different multiplexing configurations are present in the two terminal transmission stations. As the transmission station at one end has another multiplexer configuration than the one at the other end, only the digital blocks are deemed to exist that can be manipulated at both stations.

Example 1:

Lisbon and Rome are interconnected by a 34-Mbit/s line system. In Lisbon, a traditional multiplexer configuration is used (i.e. $34 \text{ Mbit/s} \diamond 8 \text{ Mbit/s} \diamond 2 \text{ Mbit/s}$). In Rome, an equipment with $34 \text{ Mbit/s} \diamond 2 \text{ Mbit/s}$ multiplexer configuration is used, without the 8-Mbit/s modulation levels. In this case, the 8-Mbit/s blocks don't exist. Only the 34-Mbit/s and the 2-Mbit/s blocks exist between Lisbon and Rome. If only the first 2-Mbit/s block exists within the first 34 Mbit/s, the designation is:

Lisboa–Roma 30N3.

(See also the example in A.4.1.2.)

8.3 Restoration digital blocks

Digital blocks set up on restoration digital paths or spare digital paths for restoration purposes will receive a serial number from the 800-series, in descending order and starting from 899.

Example:

The first fourth order restoration block between Koebenhavn and Stockholm is designated:

Koebenhavn–Stockholm 1920N899.

8.4 Multiple destination unidirectional digital blocks

For these blocks, the traffic relation is composed of the name of the sending terminal station followed by a hyphen and the letters MU (multiple destination unidirectional) in parentheses.

Superseded by a more recent version

Examples:

The first multiple destination unidirectional primary digital block from Bercenay (to, for example, London and Bruxelles) is designated:

Bercenay–(MU) 30N1.

The next multiple destination unidirectional primary digital block from Bercenay (to, for example, Frankfurt and Roma) is designated:

Bercenay–(MU) 30N2.

NOTE – Digital blocks routed via a multi-access system may be provided for exclusive use between two terminal stations only, in which case the normal designations given above in this Recommendation will apply.

8.5 Single destination unidirectional digital blocks

These blocks are designated as normal digital blocks and numbered in the same sequence. The unidirectional property as well as the direction of transmission has to be registered in Related information under item 16 (Direction of transmission) (see 15.16).

Example:

A unidirectional primary digital block transmitting in the direction Roma to London, which is the 21st primary digital block on that relation is designated:

London–Roma 30N21.

8.6 Related information

The additional information on digital blocks is covered by the following items:

- 1) urgency for restoration;
- 2) terminal countries;
- 3) Administrations', carriers' or broadcasting companies' names;
- 4) control and sub-control station(s);
- 5) fault report points;
- 6) routing;
- 7) association;
- 8) equipment information;
- 9) use;
- 10) transmission medium information;
- 11) (unassigned item, use: "–;");
- 12) bit rate;
- 13) occupancy;
- 14) actual number of channels (for primary blocks only);
- 15) clocking information;
- 16) direction of transmission (for unidirectional blocks only).

The various items will be dealt with in clause 15.

Superseded by a more recent version

9 Designation of international digital paths

In practice, it may be that terminal equipment is not connected to a digital path. Nevertheless, for designation purposes, the digital path will be designated as though digital blocks had been set up (see 8.1).

9.1 Conventional digital paths not connected to their terminal equipment

Such digital paths are included in the normal serial numbering sequence of digital blocks and are not given a separate numbering sequence.

9.2 Restoration digital paths

Digital paths nominated for restoration purposes are designated by serial numbers taken from the 800-series in ascending order and starting from 801.

Restoration paths for first order digital blocks: 30N801, 30N802, etc.

Restoration paths for second order digital blocks: 120N801, 120N802, etc.

Example 1:

The 4th second order restoration digital path between London and Paris is designated:

London–Paris 120N804.

Example 2:

The first third order restoration digital path between Amsterdam and Paris is designated:

Amsterdam–Paris 480N801.

9.3 Digital line sections and digital radio sections

Designations of digital line sections and digital radio sections are under consideration.

9.4 Related information

The additional information on digital paths is covered by the following items:

- 1) urgency for restoration;
- 2) terminal countries;
- 3) Administrations', carriers' or broadcasting companies' names;
- 4) control and sub-control station(s);
- 5) fault report points;
- 6) routing;
- 7) association;
- 8) equipment information;
- 9) use;
- 10) transmission medium information;
- 11) (unassigned item, use: "–");
- 12) bit rate.

The various items will be dealt with in clause 15.

Superseded by a more recent version

10 Designations of routes⁴ in the mixed analogue/digital transmission network

Conforming to the philosophy for lining-up and maintaining a mixed analogue/digital transmission network (Recommendation M.20 [19]), the analogue and digital parts of the network are designated separately. To indicate that the end-to-end transmission relies on a mixture of analogue and digital transmission systems, the letter C is included in both the analogue and digital designations. The function code may, therefore, consist of a maximum of 6 characters.

Transmultiplexer equipment is included in the designation of the analogue part of the route.

10.1 Transmission routes with one analogue-to-digital conversion

10.1.1 Groups and supergroups, etc., forming part of a mixed analogue/digital transmission route

Groups, supergroups, etc., which are converted into digital paths at some point are designated in the same way as conventional groups or supergroups (see 5.1), but have a letter C included in the function code and placed after the nominal number of channels.

Examples:

Group:	London–Riyadh 12C02 Amsterdam–Koebenhavn 12C899 (restoration group)
Supergroup:	Paris–Sydney 60C01
Mastergroup:	Bruxelles–London 300C03
Supermastergroup:	Amsterdam–Paris 900C04

Figure 2 shows a typical analogue/digital arrangement and how it will be designated.

10.1.2 Digital blocks and paths forming part of a mixed analogue/digital transmission route

Digital blocks and paths which are converted into analogue groups, supergroups, etc., at some point, are designated in the same way as conventional digital blocks and paths, but have an additional letter C placed after the letter N.

Example:

Madrid–Roma 480NC1.

Figure 2 shows a typical analogue/digital arrangement and how it will be designated.

⁴ This term is used provisionally in this context to designate various combinations of analogue and digital sections with appropriate intermediate equipment and usually also including terminal equipment, as illustrated in Figures 2 and 3.

Superseded by a more recent version

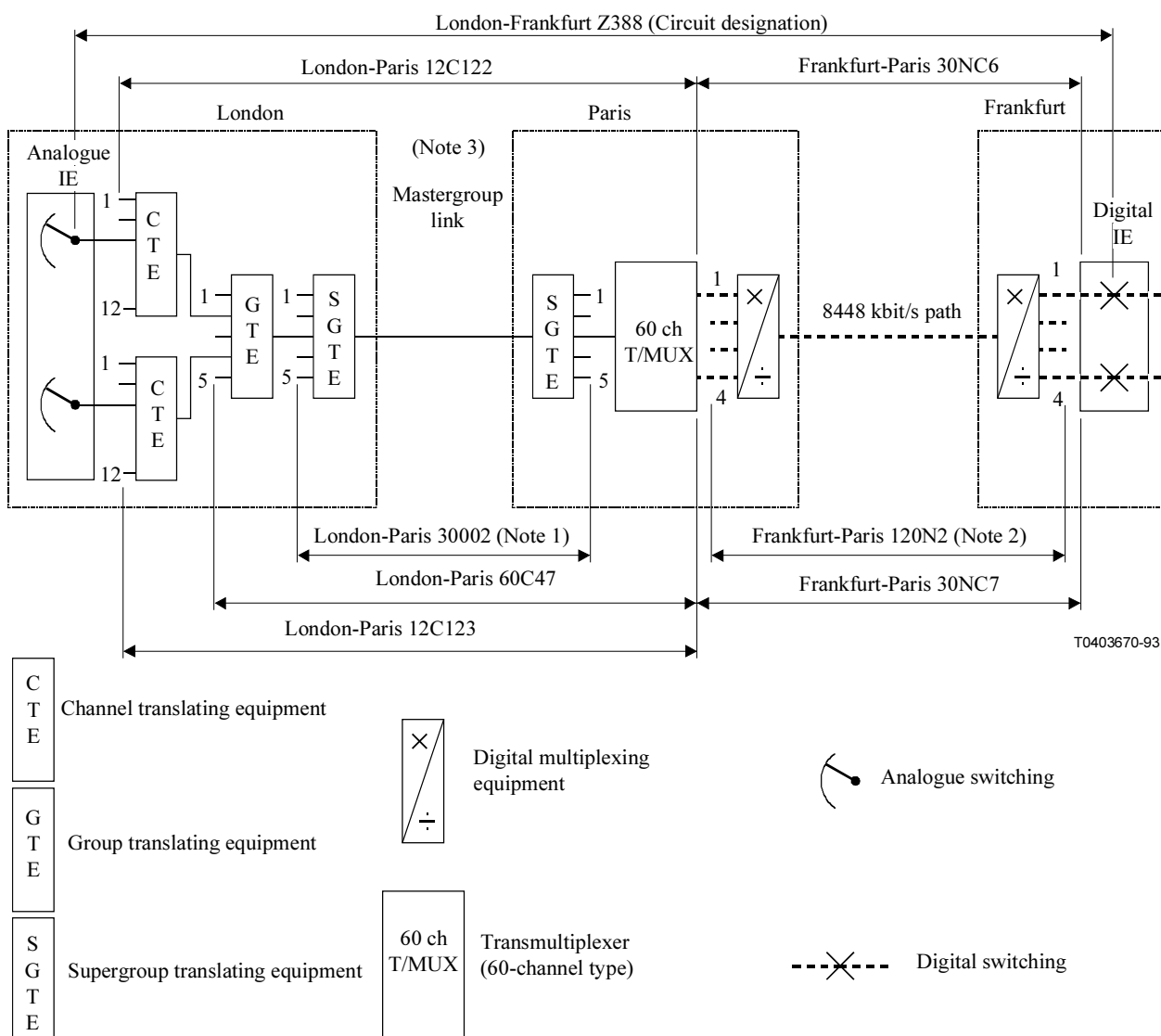

NOTE 1 – The conventional analogue designation is used.
 NOTE 2 – The conventional digital designation is used.
 NOTE 3 – Mastergroup link equipment is assumed and not shown here.

Figure 2/M.1400 – Example of a transmission route involving one analogue-to-digital conversion, showing how the various parts will be designated

10.1.3 End-to-end designations

This subject is covered by item 11 in related information for digital blocks (see 15.11).

10.2 Transmission routes with two analogue-to-digital conversions

10.2.1 End-to-end designations

Where both ends of a route involving two analogue-to-digital conversions are analogue, an end-to-end designation using the analogue notation described in 10.1.1 should be agreed between the terminal Administrations.

Superseded by a more recent version

Where both ends are digital, an end-to-end designation using the digital notation described in 10.1.2 should be agreed between the terminal Administrations.

By the above means, both terminal stations have available a common designation for the end-to-end transmission route, and are informed of its mixed analogue/digital nature.

10.2.2 Intermediate section designation

The intermediate part of the route is given a separate designation using the appropriate notation. The choice of this designation is the responsibility of the Administrations providing the intermediate part of the route, and it is their responsibility to associate, in their records, this intermediate designation with the overall designation.

Figure 3 shows two examples of routes involving two analogue-to-digital conversions and how they will be designated.

10.3 Transmission routes with more than two analogue-to-digital conversions

The transmission planning rules given in clause 3/G.113 [11] effectively restrict the number of unintegrated digital processes (e.g. analogue-to-digital conversions) permitted in the international part of a telephone connection. Similarly, the routing plan given in Recommendation E.171 [12] restricts the number of international circuits in a connection to four.

In view of these rules, it is desirable to limit the number of analogue-to-digital conversions in each direction between international centres to a maximum of two. Therefore, the detailed designation requirements of routes with more than two analogue-to-digital conversions are not considered.

10.4 Related information

The additional information on groups and blocks in the mixed analogue/digital network is covered by the same items as analogue groups and digital blocks respectively. However, item 11 "End-to-end information" is used in addition (see 7.11 and 15.11).

11 Designation of data transmission systems

11.1 General

This subclause deals with data transmission systems provided between the premises of Administrations. (Those between renters' premises are designated according to 3.2.15 concerning digital leased circuits connecting two locations.) Individual international 56 or 64 kbit/s time slots (e.g. rented as single bearers in submarine cables) are considered as data transmission links and get a designation accordingly. For an example, see 11.2.

The designation scheme of these data transmission systems can only be used if they are non-hierarchical or not formatted according to the Recommendations G.734, G.736, G.742, G.743, G.745, G.751, G.752, G.753 and G.754 [10]. This means that digital blocks from a digital multiplex hierarchy, with a format defined in Recommendation G.702 [13] cannot have a designation taken from this subclause. They should be designated according to clause 8. The bit rates for these blocks, defined in Recommendation G.702 are: 1544 kbit/s, 2048 kbit/s, 6312 kbit/s, 8448 kbit/s, 32 064 kbit/s, 34 368 kbit/s, 44 736 kbit/s, 97 728 kbit/s and 139 264 kbit/s.

NOTE – This subclause deals with digital transmission only. Analogue data transmission systems and links are covered by the subclauses treating circuits, groups and group links.

Superseded by a more recent version

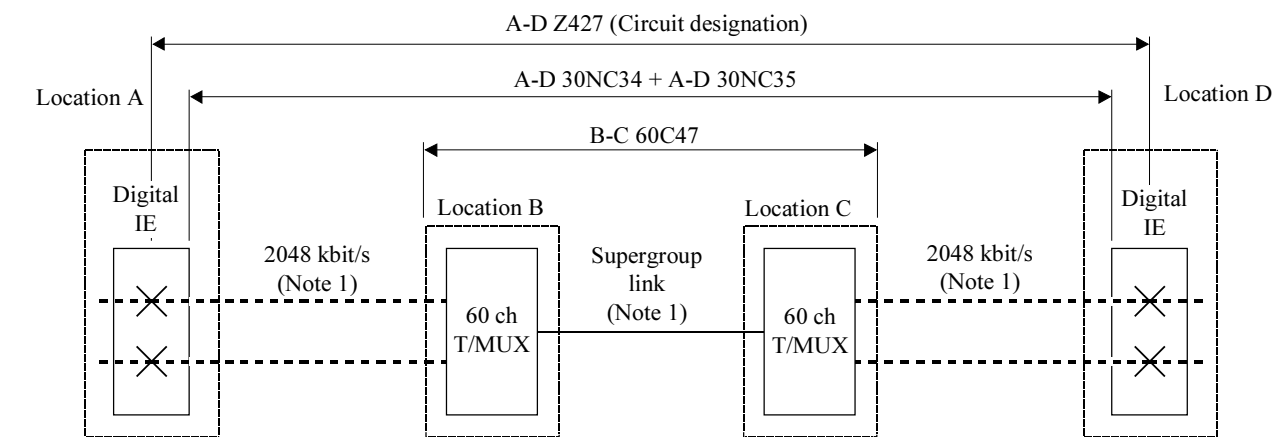

a) Digital-analogue-digital route

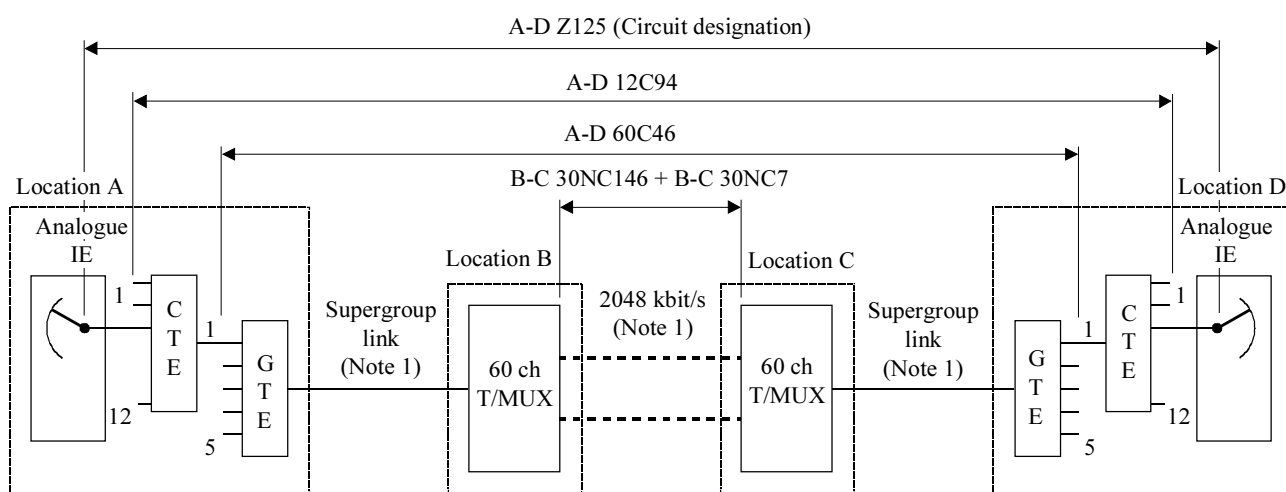

T0403680-93

b) Analogue-digital-analogue route

IE International exchange

NOTE 1 – Higher-order groups and digital blocks would be designated in the conventional manner.

NOTE 2 – Symbols are defined in Figure 2.

Figure 3/M.1400 – Examples of transmission routes involving two analogue-to-digital conversions, showing how the various parts will be designated

The format of designations of data transmission systems are shown in Table 7.

Superseded by a more recent version

Table 7/M.1400

Format of designation	Town A	/	Suffix for transmission station or international exchange (optional)	–	Town B	/	Suffix for transmission station or international exchange (optional)		Function code	Serial number
Signs	Characters	Slash	Letters/digits	Hyphen	Characters	Slash	Letters/digits	Space	Letters/digits	Digits
Number of characters	≤ 12	1	≤ 3	1	≤ 12	1	≤ 3	1	≤ 5	1 to 3
									↑	No space

The elements of the format are as follows:

a) *Traffic relation*

Town A and town B, possibly with a transmission station or international exchange suffix, represent the two terminal stations of the data transmission system. The names are arranged in alphabetical order. For the spelling, see 1.1. If the town name exceeds the maximum length of 12 characters, the responsible Administration should supply a suitable abbreviation which must be unique (see 0.1).

The suffix for the transmission station or international exchange (maximum 3 characters), although optional, is recommended for all new and modified records, to identify the terminal point of the international carrier providing the data transmission system, when there is more than one carrier operating in the same town. The necessity for a suffix and its form should be decided by the Administration operating the data transmission system in the town concerned.

b) *Function code*

This code consists of a 2- to 4-digit number which, together with a letter showing the multiplication factor, indicates the bit rate.

The letters to be used to indicate the multiplication factor are:

<i>Bit rate of system</i>	<i>Letter</i>
Up to 999 bit/s	B
1000 to 9999 bit/s	H
10 000 to 9 999 999 bit/s	K
10 000 000 to 9 999 999 999 bit/s	M

c) *Serial number*

This is a 1- to 3-digit number counting the number of data transmission systems with the same traffic relation and the same function code.

NOTE – The use of the data transmission system (e.g. multiplex of digital leased circuits, broadcasting, video) will be recorded in Related information under item 9 (Use) (see 15.9).

Example 1:

The first 9600 bit/s data transmission system between Lisbon RM1 and New York (for example, in use for a multiplex of 2400 bit/s and 7200 bit/s circuits):

Lisboa RM1–New York 96H1.

Superseded by a more recent version

Example 2:

The eleventh 2048 kbit/s data transmission system between London and Paris (used, for example, for public video conference):

London–Paris 2048K11.

Example 3:

The first 512 kbit/s data transmission system (in use as an Intermediate Data Rate satellite carrier, rented from INTELSAT) between Dubai and Sintra satellite earth stations (used, for example, for public telephone service):

Dubai-Sintra 512K1.

11.2 Data transmission links

Data transmission links are designated as data transmission systems.

Example:

In TAT-9, several single bearers between New York and London are in operation being rented from the cable operating company by PTT Telecom in The Netherlands. The first international single 64 kbit/s bearer gets the designation:

London/XYZ–New York/ABC 64K1.

NOTE 1 – The suffix has to be agreed between the cable operating company and PTT Telecom or can simply be PTT.

NOTE 2 – If the bearer is in use for the leased circuit Amsterdam/PTT–New York/ABC NP25, the occupancy is as follows:

London/XYZ–New York/ABC 64K1

1. Amsterdam/PTT–New York/ABC NP25

If the bearer would be idle, the occupancy is: 1.

Reference is made to Annex B to this Recommendation which shows a more detailed example and the remaining part of routing from London to Amsterdam.

11.3 Related information

The additional information on data transmission systems is covered by the following items:

- 1) urgency for restoration;
- 2) terminal countries;
- 3) Administrations', carriers' or broadcasting companies' names;
- 4) control and sub-control station(s);
- 5) fault report points;
- 6) routing;
- 7) association;
- 8) equipment information;
- 9) use;
- 10) transmission medium information;
- 11) composition of transmission;
- 12) (unassigned item, use: "–;");

Superseded by a more recent version

13) occupancy.

The various items will be dealt with in clause 15.

12 Designations of international digital blocks created by the interconnection of Digital Circuit Multiplication Equipments (DCMEs)

12.1 General

The format of the designation of digital blocks created by the interconnection of DCMEs is shown in Table 8:

Table 8/M.1400

Format of designation	Town A	/	Suffix for transmission station or international exchange (optional)	–	Town B	/	Suffix for transmission station or international exchange (optional)	Space	Function code	Serial number
Signs	Characters	Slash	Letters/digits	Hyphen	Characters	Slash	Letters/digits	Space	Letters/digits	Digits
Number of characters	≤ 12	1	≤ 3	1	≤ 12	1	≤ 3	1	2 to 4	≤ 4
									↑ No space	

The elements of the format are as follows:

a) *Traffic relation*

Town A and town B, possibly with a suffix for the transmission station or international exchange, indicate the terminal points of the block. For the spelling, see 1.1. If a town name exceeds the maximum length of 12 characters, the Administration should apply a suitable abbreviation which must be unique (see 0.1). The town names are arranged in alphabetical order.

The suffix for the transmission station or international exchange (maximum 3 characters), although optional, is recommended for all new and modified records, to identify the terminal point of the international carrier providing the created digital block when there is more than one carrier operating in the same town. The necessity for a suffix and its form should be decided by the Administration operating the created digital block in the town concerned.

b) *Function code*

This code consists of a number indicating the nominal maximum number of channels in the block followed by the letter Y.

c) *Serial number*

This is a 1- to 4-digit number which counts the number of blocks with the same traffic relation and the same function code.

Example 1:

The second block created by the interconnection of DCMEs with a nominal maximum number of 240 channels between Frankfurt and Melbourne will be designated:

Frankfurt–Melbourne 240Y2.

Superseded by a more recent version

Example 2:

A block is created by the interconnection of DCMEs, and routed via a 512 kbit/s data transmission system. This data transmission system is an Intermediate Data Rate digital satellite carrier rented from INTELSAT (with 8×64 kbit/s bearer channels). Only one port will be used at both DCMEs. The first of such blocks to be established between Lisbon and Hong Kong will be designated:

Hong Kong-Lisboa 30Y1.

12.2 Multi-clique configuration of DCMEs

If the created block is partly directed to destination B and partly to C (Figure 4) the designation of the blocks is:

Town A/sfx – Town B/sfx $n_1 n_1 n_1 Y xxxx$

Town A/sfx – Town B/sfx $n_2 n_2 n_2 Y xxxx$

– $n_1 n_1 n_1, n_2 n_2 n_2$ are the numbers of channels dedicated to that relation (multiples of 30)

– $n_1 n_1 n_1 + n_2 n_2 n_2 =$ the capacity of the DCME.

Example:

London–New York 120Y₁

London–Pittsburg 120Y₁

The same designation applies to the configuration in Figure 5 ($A_1 - B_1, A_1 - B_2, A_2 - B_1$ and $A_2 - B_2$).

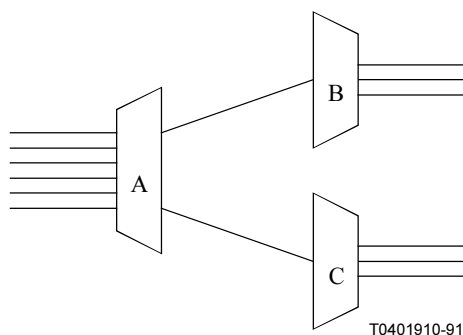

Figure 4/M.1400

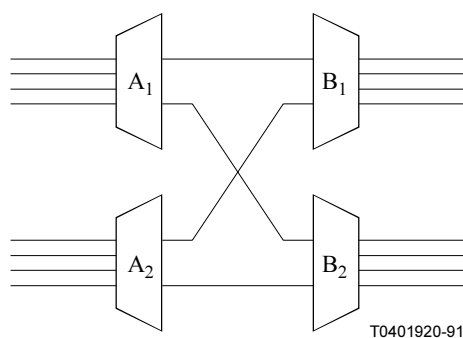

Figure 5/M.1400

Superseded by a more recent version

12.3 Low Rate Encoding Equipment

Low Rate Encoding Equipment is considered as a special case of DCMEs.

If two of these equipments are linked by, using a 2-Mbit/s path, the designation 60Y (if multiplication factor = 2) should be applied.

For LREs linked by paths with other bit rates, the function code to be used is also dependent on the nominal maximum number of channels allowed by the configuration.

Example:

A block is created by the interconnection of LREs, and routed via a 512-kbit/s data transmission system. This data transmission system is an Intermediate Data Rate digital satellite carrier rented from INTELSAT (with 8×64 kbit/s bearer channels). The multiplication factor is 2. The first of such blocks to be established between Linda Velha and Beijing will be designated:

Beijing-Linda Velha 16Y1.

12.4 Related information

The additional information digital blocks created by the interconnection of DCMEs is covered by the following items:

- 1) urgency for restoration;
- 2) terminal countries;
- 3) Administrations', carriers' or broadcasting companies' names;
- 4) control and sub-control station(s);
- 5) fault report points;
- 6) routing;
- 7) association;
- 8) equipment information;
- 9) use;
- 10) transmission medium information;
- 11) (unassigned item, use: "-;");
- 12) bit rate;
- 13) occupancy.

The various items will be dealt with in clause 15.

13 Designations of international Virtual Containers

13.1 General

This subclause refers to Virtual Containers of the Synchronous Digital Hierarchy as defined in Recommendation G.707 [20].

The format of the designation of Virtual Containers is shown in Table 9.

The elements of the format are as follows:

a) *Traffic relation*

Town A and town B, possibly with a transmission station or international exchange suffix, represent the two terminal stations of the data transmission system. The names are arranged

Superseded by a more recent version

in alphabetical order. For the spelling, see 1.1. If the town name exceeds the maximum length of 12 characters, the responsible Administration should supply a suitable abbreviation which must be unique (see 0.1).

The suffix for the transmission station or international exchange (maximum 3 characters), although optional, is recommended for all new and modified records, to identify the terminal point of the international carrier providing the virtual container when there is more than one carrier operating in the same town. The necessity for a suffix and its form should be decided by the Administration operating the virtual container in the town concerned.

Table 9/M.1400

Format of designation	Town A	/	Suffix for transmission station or international exchange (optional)	–	Town B	/	Suffix for transmission station or international exchange (optional)	Space	Function code	Serial number
Signs	Characters	Slash	Letters/digits	Hyphen	Characters	Slash	Letters/digits	Space	Letters/digits	Digits
Number of characters	≤ 12	1	≤ 3	1	≤ 12	1	≤ 3	1	4 to 5	≤ 4
									↑ No space	

b) *Function code*

This code is the following:

VC11S for a VC-11 Virtual Container

VC12S for a VC-12 Virtual Container

VC2S for a VC-2 Virtual Container

VC3S for a VC-3 Virtual Container

VC4S for a VC-4 Virtual Container

c) *Serial number*

This is a 1- to 4-digit number which counts the number of Virtual Containers with the same traffic relation and the same function code.

Example:

The tenth VC-4 Virtual Container between Barcelona and Toulouse is designated:

Barcelona–Toulouse VC4S10.

13.2 Related information

The additional information on Virtual Containers is covered by the following items:

- 1) urgency for restoration;
- 2) terminal countries;
- 3) Administrations', carriers' or broadcasting companies' names;
- 4) control and sub-control station(s);
- 5) fault report points;
- 6) routing;

Superseded by a more recent version

- 7) association;
- 8) equipment information;
- 9) use;
- 10) transmission medium information;
- 11) (unassigned item, use: "-;");
- 12) (unassigned item, use: "-;");
- 13) occupancy;
- 14) access point identifiers.

The various items will be dealt with in clause 15.

14 Designation of multiplex sections of the Synchronous Digital Hierarchy (SDH)

14.1 General

This subclause deals with multiplex sections of the SDH (STMs) as defined in Recommendation G.707 [20].

The format of designation of multiplex sections is shown in Table 10:

Table 10/M.1400

Format of designation	Town A	/	Suffix for transmission station or international exchange (optional)	–	Town B	/	Suffix for transmission station or international exchange (optional)	Space	Function code	Serial number
Signs	Characters	Slash	Letters/digits	Hyphen	Characters	Slash	Letters/digits	Space	Letters/digits	Digits
Number of characters	≤ 12	1	≤ 3	1	≤ 12	1	≤ 3	1	2 to 4	1 to 3
									↑ No space	

The elements of the format are as follows:

a) *Traffic relation*

Town A and town B, possibly with a transmission station or international exchange suffix, represent the two terminal stations of the multiplex section. The names are arranged in alphabetical order. For the spelling, see 1.1. If the town name exceeds the maximum length of 12 characters, the responsible Administration should supply a suitable abbreviation which must be unique (see 0.1).

The suffix for the transmission station or international exchange (maximum 3 characters), although optional, is recommended for all new and modified records, to identify the terminal point of the international carrier providing the multiplex section when there is more than one carrier operating in the same town. The necessity for a suffix and its form should be decided by the Administration operating the multiplex section in the town concerned.

Superseded by a more recent version

b) *Function code*

This code consists of a number (1 to 3 digits) indicating the nominal number of VC-4s which can be carried by the multiplex section followed by the letter S.

c) *Serial number*

This is a 1- to 3-digit number counting the number of multiplex sections with the same traffic relation and the same function code.

Example:

The eleventh multiplex section STM-16 (bit rate = 16×155 Mbit/s) between London and Paris is designated:

London–Paris 16S11.

14.2 Related information

The additional information on multiplex sections is covered by the following items:

- 1) urgency for restoration;
- 2) terminal countries;
- 3) Administrations', carriers' or broadcasting companies' names;
- 4) control and sub-control station(s);
- 5) fault report points;
- 6) routing;
- 7) association;
- 8) equipment information;
- 9) use;
- 10) transmission medium information;
- 11) (unassigned item, use: "-;");
- 12) bit rate;
- 13) occupancy;
- 14) access point identifiers.

The various items will be dealt with in clause 15.

15 Related information for international digital blocks, paths, data transmission systems, blocks created by the interconnection of DCMEs, Virtual Containers and SDH multiplex sections

The following sections explain the items of Related information concerned with international digital blocks, paths, data transmission systems, blocks created by the interconnection of DCMEs, Virtual Containers and SDH multiplex sections. Full examples of the designation information of an international digital block, an international digital path, an international data transmission system, an international block created by the interconnection of DCMEs, an international Virtual Container and an international SDH multiplex section are given in A.4.

15.1 Urgency for restoration [item 1)]

This item supplies information on the urgency of restoration of the block, path, etc. based upon bilateral agreement between the terminal Administrations.

Superseded by a more recent version

Format:

1. xx xx; (maximum 10 characters)

Illustration:

- a) If the priority is top: 1;
If the priority is second: 2;
If the priority is third: 3; or
- b) If repair is required within e.g. 24 hours: ≤ 24 h; or
- c) If no urgency has to be indicated: –;

Example:

If a block needs top priority in the case of restoration:

1. 1;

15.2 Terminal countries [item 2]

This item presents the countries in which the block, path, etc., is terminating.

Format:

2. XXX, YYY; (3 characters for each) or 2. XXX;

Specification:

XXX: code for country of town A

YYY: code for country of town B

In the case of multiple destination unidirectional block, only XXX applies.

NOTE – The codes are according to ISO Standard 3166 [2].

Example:

For a digital block Bruxelles–Frankfurt 120N1:

2. BEL, DEU;

15.3 Names of Administration, carriers or broadcasting companies [item 3]

This item records the names of the carriers, etc., which operate the block, path, etc. The applicable carrier codes can be selected from the ITU-T "List of International Carrier Codes" [22].

Format:

3. XXXXXX, YYYYYY; (maximum 6 characters for each) or 3. XXXXXX;

Specification:

XXXXXX: name of company in town A

YYYYYY: name of company in town B

In the case of a multiple destination unidirectional block, only XXXXXX applies.

Example:

For a digital block Frankfurt–London 30N1 operated by BT (British Telecom) and Deutsche Telekom:

3. DBP, BT;

Superseded by a more recent version

15.4 Control station [sub-control station(s)] [item 4]

This item lists the appointed control station and sub-control stations (according to Recommendations M.80 [15] and M.90 [16]). Further details about the stations can be found in the list of contact points (Recommendation M.1510 [17]).

Format:

- 4. CS: designation of control station,
- SCS1: designation of sub-control station,
- SCS2: designation of sub-control station,
- ⋮ ⋮
- SCSn: designation of sub-control station,

or, in the case of a multiple destination unidirectional block:

- 4. CS: designation of control station.

Specification:

- CS: designation of the control station,
- SCS1: designation of the terminal sub-control station,
- SCS2 to SCSn: if applicable, other sub-control stations are to be placed in the geographical order according to the traffic relation.

In the case of a multiple destination unidirectional block, only CS applies.

Example 1:

For the digital block Stockholm–Venezia 30N1 with control station Stockholm and sub-control stations Venezia and Paris:

- 4. CS: Stockholm/HAM;
- SCS1: Venezia/CEN;
- SCS2: Paris/ARC;

Example 2:

For the digital block Rio de Janeiro–(MU) 30N1:

- 4. CS: Rio de Janei/1:

15.5 Fault report points [item 5]

This item presents the names of both fault report points on the block, path, etc. (according to Recommendation M.2130 [18]). Further details about the fault report points can be found in the list of contact points (Recommendation M.1510 [17]).

Format:

- 5. Designation of fault report point, Designation of fault report point

or

- 5. Designation of fault report point;

Specification:

The first fault report point is the one of country of town A.

The second fault report point is the one of country of town B.

Superseded by a more recent version

In the case of a multiple destination unidirectional block, the second station and the comma are omitted.

Example 1:

For the digital block Lisboa–Zuerich 30N1:

5. Lisboa/PCS, Zuerich/SEL;

Example 2:

For the digital block Jakarta-(MU) 30N1:

5. Jakarta/1;

15.6 Routing [item 6)]

This item records the next higher block within the multiplex hierarchy on which the block, path, Virtual Container, multiplex sections, etc., has been routed and the position number, or in the case of the highest multiplex level, the transmission media on which the block has been routed.

Format:

6. Designation of an international block/position number or designation of transmission medium, Designation of an international block/position number or designation of transmission medium, . . ., Designation of an international block/position number or designation of transmission medium.

NOTE 1 – For the case of a lower order Virtual Container (VC), the position number should be given using KLM addressing. KLM addressing is described in 7.3/G.707 [20]. Also, refer to Annex B for a description of how KLM addressing relates to time slot numbering.

NOTE 2 – Two consecutive unidirectional blocks are separated by a + sign instead of a comma.

Specification:

The designation of an international block refers to the next higher level in the digital multiplex hierarchy. If there are more than one, the blocks are noted in geographical order from town A to town B.

The designation of the transmission medium refers to the transmission medium leaving the country of town A and to the transmission medium entering the country of town B respectively.

As no CCITT/ITU-T designations of transmission media, nor digital line or radio sections are recommended for the time being, the terminal countries should provide designations or agree on designations.

If there is only one transmission medium, the designation of this medium applies.

Example 1:

For the primary digital block Frankfurt–Zuerich 30N7:

6. Frankfurt–Zuerich 120N1/3;

Example 2:

For the block Bruxelles–London 1920N1, with transmission medium corresponding to submarine cable:

6. UK–B 5;

Superseded by a more recent version

15.7 Association [item 7]

This item identifies whether there are associated blocks, paths, data transmission systems, digital blocks created between DCMES, Virtual Containers and SDH multiplex sections, and if so, of what type.

Format:

7. Association code: designation(s) of the associated block(s), path(s), etc.;

15.7.1 Information on reserve blocks, paths, data transmission systems created digital blocks between DCMEs, Virtual Containers and multiplex sections

Specification:

If the block *has* a reserve block, the association code is: S followed by the function code and the serial number of the principal block.

If the block *is* a reserve block, the association code is: function code followed by S and the serial number of the reserve block.

The same applies for digital paths, data transmission systems, etc.

Example:

If the path Hongkong–Singapore 30N801 is the restoration path for the normal block Hongkong–Singapore 30N3, the Related information for the normal block under Association must show:

7. S30N3: Hongkong–Singapore 30N801;

15.7.2 Information on diverse routing

Specification:

If a block is required to be routed on a different route than other blocks, the association code is DVR followed by the designation of the other blocks.

The same applies for digital paths, data transmission systems, etc.

Example:

If a block Amsterdam–Paris 30N7 is required to be routed on a different route than the blocks Amsterdam–Bruxelles 30N12 and Bruxelles–Paris 30N2, the related information for the block Amsterdam–Paris 30N7 under Association must show:

7. DVR: Amsterdam–Bruxelles 30N12,
Bruxelles–Paris 30N2;

NOTE – The codes listed in 15.7.1 and 15.7.2 may both appear under Association.

15.7.3 Information on consecutive routing

Specification:

If the time slots in a block carry traffic that is consecutively routed on international single bearers, the block and the single bearers get an Association code, namely:

PLR = part of a longer route.

Superseded by a more recent version

Example:

If five single bearers (see the example in 11.2) are connected in London to five time slots in the international 2-Mbit/s digital block Amsterdam/PTT–London/XYZ 30N1, the Association is as follows:

Amsterdam/PTT–London/XYZ 30N1

7. PLR: London/XYZ–New York/ABC 64 K1,
London/XYZ–New York/ABC 64 K2,
London/XYZ–New York/ABC 64 K3,
London/XYZ–New York/ABC 64 K4,
London/XYZ–New York/ABC 64 K5;

Similar for each of the single bearers e.g. for London/XYZ – New York/ABC 64K1:

7. PLR: London/XYZ–New York/ABC 30N1

15.8 Equipment information [item 8]

15.8.1 This item records information on equipment in the block, path, etc., which requires special maintenance attention

Format:

8. XX, XX, XX, XX;

Specification:

If the block has been routed via TDMA: TD.

If the block has been created by the interconnection of two transcoders (Low Rate Encoding equipment) using the A-law: AI or m-law: MI.

NOTE – If there is a need to record any additional equipment information, the next free codeplaces are available for that purpose. The codes to be used must consist of two characters, be unique and can be chosen by bilateral agreement between Administrations.

15.8.2 For data transmission systems, this item supplies information about the multiplex configuration

Format for data transmission systems only:

8. XXXXXXYYYYZZZZ;

Specification:

XXXXXX refers to the Recommendation series,

YYYY refers to the Recommendation number,

ZZZZZ refers to the clause, subclause, table, etc., number.

Example:

For a 9600-bit/s data transmission system with a multiplex configuration as defined in Table E.1, item 8 will present:

8. Rec. M.1400T12;

Superseded by a more recent version

15.8.3 For blocks created by the interconnection of DCMEs, this item provides information on through-going channels (which are transmitted even if a DCME fails) and derived channels (which are not transmitted if a DCME fails)

Format:

8. XXXXXXXX = Y;

Specification:

XXXXXXX indicates a range of positions (e.g. 1-30), on all even positions (EP), on all odd positions (OP).

Y indicates whether these positions are through-going (T) or derived (D).

Example 1:

If the 30 first channels of a 240Y block are through-going, item 8 will be:

8. 1-30 = T;

Example 2:

If the even positions of a 60Y block created by the interconnection of two transcoders are derived, item 8 will be:

8. EP = D;

15.9 Use [item 9]

This item identifies for what purpose the block, path, data transmission system is used (if this known by the Administration and is of use for maintenance).

Format:

9. XXXXXX; (maximum 6 characters)

Specification:

XXXXXX refers to (among others) the designatory letters Z, B, D, V, etc., to indicate the use of the block. If no information is available, the sign – is used.

Example:

If the digital block Frankfurt–Luxembourg 30N1 is used for sound-programme transmission:

9. R;

15.10 Transmission medium information [item 10]

This item identifies whether a satellite is involved in the routing.

Format:

10. ST; or –;

Specification:

If the block has been routed via satellite: ST

If the block has not been routed via satellite: –.

Superseded by a more recent version

Example:

For the block Paris–(MU) 30N1:

10. ST;

15.11 End-to-end information or composition of transmission [item 11]

15.11.1 End-to-end information (for blocks and paths on mixed analogue/digital routes only)

This item provides information on the destinations of the traffic carried by the block or path.

Format:

11. X . . . X, Y . . . Y; (maximum 12 characters each) or –;

Specification:

X . . . X and Y . . . Y are the names of a town and refer to the destinations of the traffic on the block/path. The destinations are placed according to the order of towns in the traffic relation.

If the block has multiple destination the town name is replaced by the code: M.

If the block is within a digital environment X . . . X, Y . . . Y is replaced by the sign –.

Example 1:

For primary digital block Frankfurt–Paris 30NC6 carrying from Frankfurt–London:

11. Frankfurt, London;

Example 2:

For primary block Amsterdam–Bruxelles 30NC146 carrying traffic from London to Luxembourg:

11. London, Luxembourg;

15.11.2 Composition of transmission (for data transmission systems)

This item shows the type of transmission on the data transmission system.

Format:

11. A; N; or C;

Specification:

If the transmission is analogue: A

If the transmission is digital: N

If the transmission is mixed analogue/digital: C

15.12 Bit rate (for blocks, paths and SDH multiplex sections) [item 12]

This item shows the bit rate of the block, path or multiplex section.

Format:

12. xxxx.x kbit/s or Mbit/s;

Rules for the notation of the bit rate figures:

Leading zeros may be omitted and if the decimal is a zero, this decimal and the decimal sign may also be omitted.

Superseded by a more recent version

If the figure is up to 9 999 999, use kbit/s.

If the figure is 10 000 000 or more, use Mbit/s.

NOTE – For data transmission systems and virtual containers, use the sign –.

Example 1:

For the digital block New York–Tokyo 24N2:

12. 1544 kbit/s;

Example 2:

For the digital block Bruxelles–Luxembourg 480N1:

12. 34 Mbit/s;

15.13 Occupancy (except for paths) [item 13]

This item lists the occupancy of the block expressed by the next lower blocks and/or circuits and/or data transmission systems which have been routed in the block.

Format in the case of a primary block:

13. Time slot number: designation of the circuit, or the sign –,
 : :
 Time slot number: designation of the circuit, or the sign –;

Format in the case of a secondary or higher level block:

13. Position number: designation of a block, of a leased circuit, of a data transmission system or
 the sign –,
 : :
 Position number: designation of a block, of a leased circuit, of a data transmission system or
 the sign –;

Format in the case of a data transmission system:

1. Position number: designation of the circuit,
 : :
n. Position number: designation of the circuit;

NOTE – Alternatively, instead of the position number, the channel numbering according to Annex E may be applied.

Specification:

If the position number is occupied by a next lower digital block: designation of this block.

If the position number is occupied by a digital leased circuit (with a bit rate corresponding to the bit rate of the next lower multiplex level): designation of this leased circuit.

If the position number is occupied by a data transmission system (with a bit rate corresponding to the bit rate of the next lower multiplex level): designation of this data transmission system.

If the position number is not in use: the sign –.

Superseded by a more recent version

Format in the case of Virtual Containers

For higher order VCs:

13. KLM number: designation of the lower order VC,
 :
 :
 KLM number: designation of the lower order VC;

For lower order VCs:

13. Designation of the digital block or digital path carried in this VC;

Format in the case of SDH Multiplex Sections

13. Position number: designation of the carried VC,
 :
 :
 Position number: designation of the carried VC;

Example 1:

For the digital block Genève–Paris 120N2:

13. 01: Genève–Lisboa 30N1,
 02: –,
 03: Genève–Paris 2048K1,
 04: Bruxelles–Wien 30N1;

Example 2:

For the digital block New York–Paris 24N5:

13. 01: New York/24–Paris/PT2 Z1,
 02: New York/24–Paris/PT2 Z3,
 03: New York/24–Paris/PT2 Z5,
 04: Paris/PT2–New York/24 Z2,
 05: Paris/PT2–New York/24 Z4,
 06: Paris/PT2–New York/24 Z6,
 07: –,
 08: –,
 09: –,
 10: Orlando/TS1–Toulouse/FER 64K1,
 11: –,
 12: –,
 13: –,
 14: –,
 15: New York/TS1–Paris/ARC R1,
 16: New York/TS1–Paris/ARC R3,
 17: –,
 18: –;

Superseded by a more recent version

- 19: –,
- 20: Paris/BEA–Washington/TS1 NP1,
- 21: –,
- 22: –,
- 23: –,
- 24: –;

Example 3:

For the VC-4 Paris–Roma VC4S12

- 13. 1,0,0: Napoli–Paris VC3S15,
- 2,1,0: Lille–Roma VC2S8,
- 2,2,0: Lille–Roma VC2S121,
- 2,3,0: –,
- 2,4,1: London–Roma VC12S30,
- 2,4,2: Paris–Roma VC12S4,
- 2,4,3: London–Roma VC12S31,
- 2,5,0: London–Roma VC2S67,
- 2,6,0: –,
- 2,7,0: Paris–Roma VC2S82,
- 3,0,0: Napoli–Paris VC3S16;

Example 4:

For the multiplex section London–Paris 4S1

- 13. 1: Glasgow–Paris VC4S12,
- 2: London–Paris VC4S21,
- 3: –,
- 4: London–Toulouse VC4S;

15.14 Actual number of channels and access point identifier [item 14]

In the case of primary blocks, 15.14.1 applies; in the case of virtual containers and SDH multiplex sections, 15.14.2 applies.

15.14.1 Actual number of channels (primary blocks only)

This item contains the actual number of channels on a primary digital block.

Format:

- 14. xxx;

Specification:

xxx indicates the actual number of channels.

For higher blocks xxx is replaced by the sign –.

Superseded by a more recent version

Example 1:

For the digital block New York–Paris 30N5 dedicated to leased circuits:

14. 31;

Example 2:

For the digital block London–New York 30N3 used for switched public telephone circuits with ADPCM, the information may be:

14. 60;

Example 3:

For the digital block Honolulu–Osaka 24N2 used for switched public telephone circuits:

14. 24;

15.14.2 Access point identifiers (virtual containers and SDH multiplex sections)

This item contains the access point identifiers associated with the trail terminations at the ends of the trail. For town A in the designation of a virtual container or a multiplex section, the APID A applies. For town B in the designation of a virtual container or a multiplex section, the APID B applies.

Format:

14. APID A: xxx...xx, (maximum 15 characters)

APID B: xxx...xx; (maximum 15 characters)

The access point identifier consists of a maximum of 15 characters and begins with either:

- a) the three alphabetic character country code as defined in ISO 3166 [2]; or
- b) the country code as defined in Recommendation E.164 [23].

For further details, see Recommendation G.831 [25].

Comments:

1. The identifiers must be unique per layer, so identifiers may be the same if and only if they belong to different VC-layers;
2. Operators within a country may apply format a) or b), but must agree together with other users of that format on how to keep the remaining part of the code unique.

Application:

1. A VC-4 Access Point in the USA: USA12345ABC6789 where 12345ABC6789 is to be designated by the responsible operator in the USA.

2. A VC-3 Access Point in the USA: USA12345ABC6789

Comment: This code may be the same as the one for the VC-4 Access Point, in accordance with Comment 1 above.

3. A VC-4 Access Point in the UK: 449876543210123 where 9876543210123 is to be designated by the operator in the UK.

4. A VC-12 Access Point in the Netherlands: NLDTCOMNL99ASD2; here the code TCOMNL99ASD2 was assigned by the operator PTT Telecom in the Netherlands.

Superseded by a more recent version

Example:

For a VC-4 between Dallas in the USA and Manchester in the UK, item 14 is specified as:

14. APIdA: USA12345ABC6789,
 APIdB: 449876543210123;

15.15 Clocking information (for blocks only) [item 15]

This item specifies whether Administrations apply a clocking system according to Recommendation G.811 [14] or use a master/slave system.

Format:

15. XX . . . XX; (maximum 30 characters)

Specification:

If clocking according to Recommendation G.811 is applied: Rec. G.811;

If a master/slave clocking is applied:

M = XX . . . XX, S = XX . . . XX;

(Town name for the master) (Town name for the slave)

Example 1:

Clocking according to Recommendation G.811:

15. Rec. G.811;

Example 2:

Clocking according to master/slave system:

15. M = London, S = Frankfurt;

15.16 Direction of transmission (for unidirectional blocks) [item 16]

This item gives information on the direction of transmission of a unidirectional digital block.

Format:

16. I; or A;

Specification:

If the block is unidirectional and if it has a single destination:

- if the direction of transmission is in alphabetical order A;
- if the direction of transmission is in inverse alphabetical order I;

Example:

For the unidirectional digital block London–Roma 30N1 transmitting in the direction Roma to London:

16. I;

Superseded by a more recent version

16 Designation of connections for the Asynchronous Transport Mode (ATM)

16.1 General

This subclause deals with connections for the ATM as defined in Recommendations I.150, I.211, I.230, I.231, I.232, I.310, I.311, I.326, I.365 and I.432.

ATM nodes are connected by transport links based on PDH hierarchies or SDH multiplex sections. On the transport links, the ATM node can open and close Virtual Paths and Virtual Channels in a semi-permanent or switched (on call) way.

The format of designation of ATM connections is shown in Table 11:

Table 11/M.1400

Format of designation	Town A	/	Suffix for transmission station or international exchange (optional)	–	Town B	/	Suffix for transmission station or international exchange (optional)		Function code	Serial number
Signs	Characters	Slash	Letters/digits	Hyphen	Characters	Slash	Letters/digits	Space	Letters/digits	Digits
Number of characters	≤ 12	1	≤ 3	1	≤ 12	1	≤ 3	1	2 to 6	1 to 4
									↑ No space	

16.2 Transport Links

The elements of the format are as follows:

a) *Traffic relation*

Town A and town B, possibly with a transmission station or international exchange suffix, represent the two terminal stations of the ATM transport link. The names are arranged in alphabetical order. For the spelling, see 1.1. If the town name exceeds the maximum length of 12 characters, the responsible Administration should supply a suitable abbreviation which must be unique (see 0.1).

The suffix for transmission station or international exchange (maximum 3 characters) is recommended for all new and changed records, though optional, to identify the terminal point of the international carrier providing the ATM transport link, when there is more than one carrier operating in the same town. The necessity for a suffix and its form should be decided by the Administration operating the ATM connection in the town concerned.

b) *Function code*

This code is the following:

E3A for 34-Mbit/s ATM transport link

D3A for 45-Mbit/s ATM transport link

NOTE – The function code for transport links using SDH multiplex sections is open to further study.

c) *Serial number*

This is a 1- to 4-digit number counting the number of transport links with the same traffic relation and the same function code.

Superseded by a more recent version

Example:

The eighth transport link at the speed of 34 Mbit/s between Lugano and Milan will be designated:
Lugano/SUI–Milano/TAT E3A8

16.3 Virtual path

The elements of the format are as follows:

a) *Traffic relation*

Town A and town B, possibly with a transmission station or international exchange suffix, represent the two terminal stations of the ATM virtual path. The names are arranged in alphabetical order. For the spelling, see 1.1. If the town name exceeds the maximum length of 12 characters, the responsible Administration should supply a suitable abbreviation which must be unique (see 0.1).

The suffix for transmission station or international exchange (maximum 3 characters) is recommended for all new and changed records, though optional, to identify the terminal point of the international carrier providing the ATM virtual path, when there is more than one carrier operating in the same town. The necessity for a suffix and its form should be decided by the Administration operating the ATM virtual path in the town concerned.

NOTE – The information about the virtual path being bidirectional or unidirectional and, in this case, the information about its origin and destination points is crucial for maintenance, and will be addressed in the related information, which is open for further study.

b) *Function code*

This code is VPA.

c) *Serial number*

This is a 1- to 4-digit number counting the number of virtual paths with the same traffic relation and the same function code.

Example 1:

The first ATM virtual path from Leeds to Köln will be designated:
Leeds–Köln VPA1

Example 2:

The transit route provided by BT for the American carrier MFS from New York USA to Frankfurt Germany will be designated:

Frankfurt/MFS–New York/MFS VPA1

16.4 Virtual channels

The elements of the format are as follows:

a) *Traffic relation*

Town A and Town B, possibly with a transmission station or international exchange suffix, represent the two terminal stations of the ATM virtual channel. The names are arranged in alphabetical order. For the spelling, see 1.1. If the town name exceeds the maximum length of 12 characters, the responsible Administration should supply a suitable abbreviation which must be unique (see 0.1).

Superseded by a more recent version

The suffix for transmission station or international exchange (maximum 3 characters) is recommended for all new and changed records, though optional, to identify the terminal point of the international carrier providing the ATM virtual channel, when there is more than one carrier operating in the same town. The necessity for a suffix and its form should be decided by the Administration operating the ATM virtual channel in the town concerned.

NOTE – The information about the virtual channel being bidirectional or unidirectional and, in this case, the information about its origin and destination points is crucial for maintenance, and will be addressed in the related information, which is open for further study.

b) *Function code*

This code is VCA.

c) *Serial number*

This is a 1- to 4-digit number counting the number of virtual channels with the same traffic relation and the same function code.

ANNEX A

Full examples for designation information

A.1 Full example for the designation information of a public switched telephone circuit

The circuit is the 604th both-way telephone circuit between Sherman Oaks 4ES and Tokyo Shinjuku, operated by AT&T and KDD. The signalling type is CCITT No. 6 with band/circuit number assigned as 000/03. The control station and sub-control station of the circuit are Sherman Oaks-transmission station 1 and Tokyo-transmission station 1 respectively. Both stations are also the fault report points of the circuit. The circuit has been routed on the 4th channel of the first group between Sherman Oaks and Ibaraki which is routed via satellite and has been connected to digital blocks in domestic networks.

Designation:

Sherman Oaks/4ES–Tokyo/SJK B604

Related Information:

1. 2;
2. USA, JPN;
3. ATT, KDD;
4. CS: Sherman Oaks/TS1,
SCS1: Tokyo/TS1;
5. Sherman Oaks/TS1, Tokyo/TS1;
6. Ibaraki–Sherman Oaks 12CO1/4;
7. –;
8. –;
9. –;
10. ST;
11. C;
12. 3.4 kHz;
13. C6, 000/03.

Superseded by a more recent version

A.2 Full example for the designation information of a leased analogue circuit

The circuit is the first analogue leased circuit used for data transmission between London and Frankfurt, operated by British Telecom International and the Deutsche Telekom. The signalling type is 500 Hz/20 Hz. The control station and sub-control station of the circuit are London Mollison and Frankfurt 0 respectively. Both stations are also the fault report points of the circuit. The circuit is routed on the 3rd channel of the first group between Frankfurt and London. As regards the parameters of the circuit, Recommendation M.1020 [9] is applied. The maintenance contract between Administrations and customer is repair within 24 hours.

Designation:

Frankfurt–London DP1

Related Information:

1. ≤ 24 h;
2. DEU, GBR;
3. DTEL, BTI;
4. CS: London/SM,
SCS1: Frankfurt/0;
5. Frankfurt/0, London/SM;
6. Frankfurt–London 1201/3;
7. –;
8. –;
9. D;
10. –;
11. A;
12. 3.4 kHz;
13. 500/20;
14. Rec. M.1020.

A.3 Full examples for the designation information of an international group and an international group link

A.3.1 Full example for the designation information of an international group

NOTE – The numbers between parentheses refer to the numbers of the items in the Related information.

The international group is the fifth group between Amsterdam and Paris. The urgency for restoration (1) is 3rd priority, the terminal countries (2) are Netherlands and France, the Administrations involved (3) are Netherlands PTT and France Telecom, the control station and sub-control station (4) are Paris Archives and Amsterdam 1 respectively, the fault report points (5) are Amsterdam 2 and Paris Archives, the routing (6) of the group is in the supergroup Amsterdam–Bruxelles 6011 on position 1 and in the supergroup Bruxelles–Paris 6002 on position 3, there is an associated group (7) carrying traffic but indicated for restoration namely Amsterdam–Paris 1209, there is special equipment involved (8) because the group is carrying companded circuits, the use (9) is: Z-circuits and a DP circuit, no satellite (10) is involved, no end-to-end information (11) is to be recorded, the bandwidth (12) is 48 kHz and the occupancy (13) is to be seen from the example.

Superseded by a more recent version

Designation:

Amsterdam–Paris 1205

Related Information:

1. 3;
2. NLD, FRA;
3. NLDPTT, FRATEL;
4. CS: Paris/ARC,
SCS1: Amsterdam/1;
5. Amsterdam/2, Paris/ARC;
6. Amsterdam–Bruxelles 6011/1,
Bruxelles–Paris 6002/3;
7. S1205: Amsterdam–Paris 1209;
8. CO;
9. Z, DP;
10. –;
11. –;
12. 48 kHz;
13. 01: Amsterdam–Paris Z111,
02: Amsterdam–Paris Z113,
03: Amsterdam–Paris Z115,
04: Amsterdam–Paris Z117,
05: Amsterdam–Paris Z119,
06: Amsterdam–Paris Z121,
07: Paris–Amsterdam Z120,
08: Paris–Amsterdam Z122,
09: Paris–Amsterdam Z124,
10: Paris–Amsterdam Z126,
11: Paris–Amsterdam Z128,
12: Amsterdam–Paris DP5.

A.3.2 Full example for the designation information of an international group link

NOTE – The numbers between parentheses refer to the numbers of the items in the Related information.

The link is the first restoration group link between Paris and Genève. The urgency for restoration (1) is 3rd priority, the terminal countries (2) are Switzerland and France, the Administrations (3) are Swiss PTT and France Telecom, the control and sub-control stations (4) are Genève Monthoux and Paris Archives respectively, the fault report points (5) are the same stations, the routing (6) is in the second supergroup between Genève and Annemasse on position 1, there is no information to be recorded about association (7), special equipment (8), use (9), there is no satellite involved (10), no end-to-end information (11) is required, the bandwidth (12) is 48 kHz.

Designation:

Genève–Paris 12801

Superseded by a more recent version

Related Information:

1. 3;
2. CHE, FRA;
3. CHEPTT, FRATEL;
4. CS: Genève/MON,
SCS1: Paris/ARC;
5. Genève/MON, Paris/ARC;
6. Annemasse–Genève 6002/1;
7. –;
8. –;
9. –;
10. –;
11. –;
12. 48 kHz;

A.4 Full examples for the designation information of an international digital block, digital path, data transmission system, blocks created between DCMEs, Virtual Containers and SDH multiplex sections

A.4.1 Full example for the designation information of an international digital block (bidirectional)

NOTE – The numbers between parentheses refer to the numbers of the items in the Related information.

A.4.1.1 Full example for the designation information of an international digital block (bidirectional symmetrical configuration)

The international digital block is the 12th primary digital block between Roma and Paris. The urgency for restoration (1) is 2, the terminal countries (2) are France and Italy, the Administrations involved (3) are France Telecom and ASST, control station (4) is Roma 1 and sub-control station is Paris Archives, the fault report points (5) are the same stations, the block has been routed (6) in the secondary digital block Paris–Roma 120N2 on position number 3, it has an associated block (7) indicated for restoration: Paris–Roma 30N5, no special equipment (8) is involved, the use of the block (9) is DP- and NP-circuits, no satellite is involved (10), no end-to-end information (11) is required, the bit rate (12) is 2048 Mbit/s, the occupancy (13) is seen in the example, the actual number of channels (14) is 31, the clocking system (15) is a master/slave system with the master in Paris and the slave in Roma.

Designation:

Paris–Roma 30N12

Related Information:

1. 2;
2. FRA, ITA;
3. FRATEL, ASST;
4. CS: Roma/1,
SCS1: Paris/ARC;
5. Paris/ARC, Roma/1;

Superseded by a more recent version

6. Paris–Roma 120N2/3;
7. S30N12: Paris–Roma 30N5;
8. –;
9. DP, NP;
10. –;
11. –;
12. 2048 kbit/s;
13. 01: London–Roma DP12,
02: Paris–Roma DP2,
03: Napoli–Rouen NP1,
04: Paris–Roma NP3,
05: Paris–Roma NP4,
06: Paris–Roma NP5,
07: –,
08: –,
09: –,
10: Lille–Roma DP1,
11: Paris–Roma DP5,
12: –,
13: –,
14: –,
15: –,
16: Bruxelles–Roma DPM4,
17: Paris–Roma DPM1,
18: –,
19: –,
20: –,
21: –,
22: –,
23: –,
24: –,
25: –,
26: –,
27: –,
28: –,
29: –,
30: –,
31: –;
14. 31;
15. M = Paris, S = Roma.

Superseded by a more recent version

A.4.1.2 Full example for the designation information of an international digital block – Bidirectional asymmetrical configuration

In the asymmetrical configuration, one transmission station has less modulation levels than the other one. In the figure below, the transmission station on the left (Palermo) uses a 2-Mbit/s \diamond 140-Mbit/s multiplexer without intermediate modulation levels. The transmission station on the right (Marseille) uses an equipment with three possible modulation schemes: 2 Mbit/s \diamond 140 Mbit/s, 2 Mbit/s \diamond 34 Mbit/s \diamond 140 Mbit/s and the traditional 2 Mbit/s \diamond 8 Mbit/s \diamond 34 Mbit/s \diamond 140 Mbit/s.

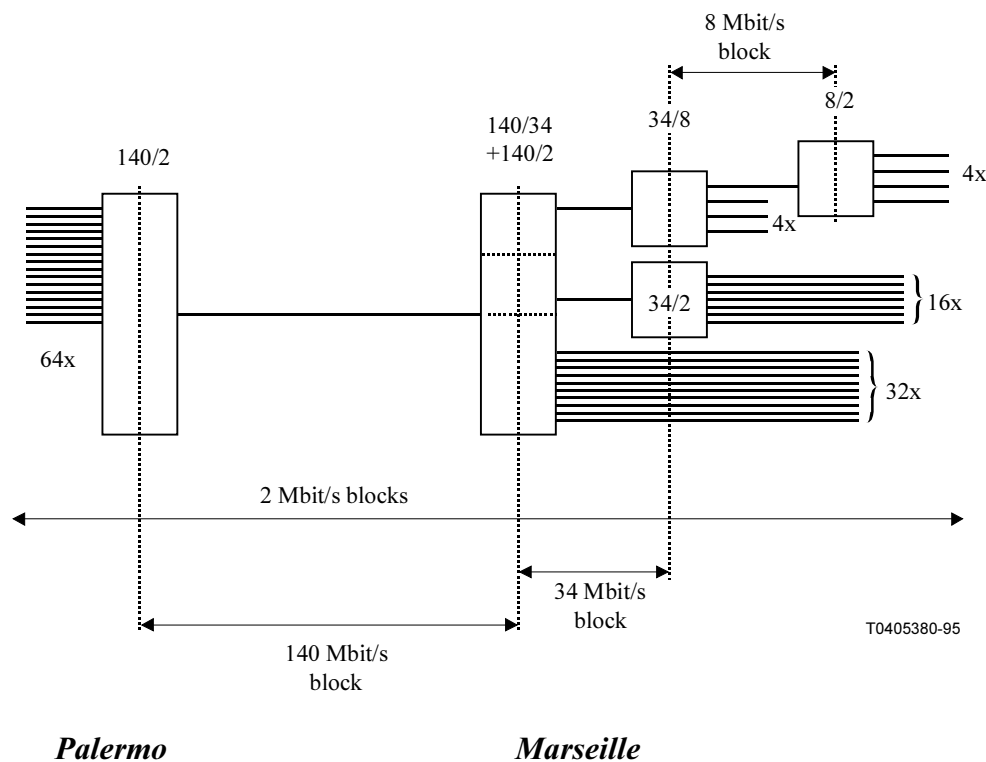

In this case, only the 2-Mbit/s and 140-Mbit/s blocks exist between Palermo and Marseille. The 8-Mbit/s and 34-Mbit/s blocks exist only between the multiplexer equipments in the transmission station at the right (Marseille). The 8-Mbit/s and 34-Mbit/s blocks do not exist internationally. Therefore no international designation is needed.

Example 1:

The international digital block is the 2nd 140 Mbit/s digital block between Palermo and Marseille. The urgency for restoration (1) is not indicated, the terminal countries (2) are France and Italy, the Administrations involved (3) are France Telecom and Telecom Italia, control station (4) is Marseille/KND and sub-control station is Palermo/L*I, the fault report points (5) are the same stations, the block has been routed (6) in the optical fiber systems Marseille–Ajaccio F01, Ajaccio–Golfo Aranci F02, Golfo Aranci–Palermo/L*I F02, it has no associated block (7) indicated for restoration, no special equipment (8) is involved, the use of the block (9) is not specified, no satellite is involved (10), no end-to-end information (11) is required, the bit rate (12) is 139 264 kbit/s, the occupancy (13) is seen in the example, the actual number of channels (14) is 64, the clocking system (15) is a master/slave system with the master in Marseille and the slave in Palermo.

Designation:

Marseille/KND–Palermo/L*I 1920N2

Superseded by a more recent version

Related Information:

1. –;
2. FRA, ITA;
3. FRATEL, TI;
4. CS: Marseille/KND
SCS1: Palermo/L*I;
5. Marseille/KND, Palermo/L*I;
6. Marseille–Ajaccio F01,
Ajaccio–Golfo Aranci F02,
Golfo Aranci–Palermo/L*I F02;
7. –;
8. –;
9. –;
10. –;
11. –;
12. 139 264 kbit/s;
13. 01: Athinai–Bracknell/BT 30N1,
02: Athinai–Bracknell/BT 30N2,
03: Dublin–Tel Aviv 30N1,
04: Athinai–Linda Velha/RM 30N1,
05: Marseille/KND–Palermo/L*I 30N1,
. .
35 –,
36: –,
37: Birkirkara/MLT–Whitehill/MCL 30N1,
38: Birkirkara/MLT–Bruxelles/BEL 30N1
. .
62: Athinai–White Plains/ATT 30N5,
63: Istanbul–Vauxhall/2 30N4,
64: –;
14. 64;
15. M = Marseille, S = Palermo.

Example 2:

Routing of a 2 Mbit/s digital block between Marseille and Palermo routed on the 5th time slot of the Marseille/KND–Palermo/L*I 1920N2

Superseded by a more recent version

Designation:

Marseille/KND–Palermo/L*I 30N1

Related Information:

6. Marseille/KND–Palermo/L*I 1920N2/5

NOTE – The related information does not describe the actual routing of the 2-Mbit/s digital block, but only its international portion. The country in which the multiplexer equipments exist (in this example, France) will document the local routing which is not the object of this Recommendation.

A.4.2 Full example for the designation information of an international digital path

NOTE – The numbers between parentheses refer to the numbers of the items in the Related information.

The international digital path is the first restoration digital second order path between Paris and Bruxelles. The urgency for restoration (1) is 3, the terminal countries (2) are Belgium and France, the Administrations involved (3) are the Belgium RTT and France Telecom, control station (4) is Bruxelles BLA and sub-control station is Paris Archives, the fault report points (5) are the same stations, the path has been routed (6) in the first third order block Bruxelles–Paris on position number 1, there are no associated blocks (7), no special equipment (8), use (9) has not been indicated, no satellite is involved (10), no end-to-end information (11) is required, the bit rate (12) is 8448 Mbit/s.

Designation:

Bruxelles–Paris 120N801

Related Information:

1. 3;
2. BEL, FRA;
3. BELRTT, FRATEL;
4. CS: Bruxelles/BLA,
SCS1: Paris/ARC;
5. Bruxelles/BLA, Paris/ARC;
6. Bruxelles–Paris 480N1/1;
7. –;
8. –;
9. –;
10. –;
11. –;
12. 8448 kbit/s.

A.4.3 Full example for the designation information of an international data transmission system

NOTE – The numbers between parentheses refer to the numbers of the items in the Related information.

The international data transmission system is the first 64-kbit/s data transmission system between London and Paris. The urgency for restoration (1) is 1, the terminal countries (2) are United Kingdom and France, the Administrations involved (3) are British Telecom International and France Telecom, the control and sub-control stations (4) are London Mollison and Paris Archives

Superseded by a more recent version

respectively, the fault report points (5) are the same stations, the system has been routed (6) in the 12th primary block between Paris and London on timeslot number 3, there is no information to be recorded about association (7), equipment information (8) and use (9), there is no satellite involved (10), composition of transmission (11) is digital, item (12) does not apply, the occupancy (13) is seen in the example.

Designation:

London–Paris 64K1

Related Information:

1. 1;
2. GBR, FRA;
3. BTI, FRATEL;
4. CS: London/SM,
SCS1: Paris/ARC;
5. London/SM, Paris/ARC;
6. London–Paris 30N12/3;
7. –;
8. –;
9. –;
10. –;
11. N;
12. –;
13. A4: London–Paris NP12,
B4: London–Toulouse NP3,
C4: –;
D4: Dublin–Paris NP6,
E4: London–Paris NP11,
F4: London–Paris NP14.

A.4.4 Full example for the designation information of a block created by the interconnection of DCMEs

NOTE – The numbers between parentheses refer to the numbers of the items in the Related information.

This block is the second block created by the interconnection of DCMEs with a maximal nominal number of 240 channels between Boston and Reims. The urgency for restoration (1) is 2, the terminal countries (2) are the United States and France, the Administrations involved (3) are AT&T and France Telecom, control station is Boston (4) and sub-control station is Reims/CRE, the fault report points (5) are the same stations, the block has been routed (6) on the 22nd primary digital path between Reims and New York, it has no associated block (7), the first 30 channels are through-going (8), use (9) has not been indicated, a satellite is involved in transmission (10), items 11 and 12 do not apply and the occupancy (13) is seen in the example (only 90 channels are occupied with circuits).

Designation:

Boston–Reims 240Y2

Superseded by a more recent version

Related Information:

1. 2;
2. USA, FRA;
3. ATT, FRATEL;
4. CS: Boston,
SCS1: Reims/CRE;
5. Boston, Reims/CRE;
6. New York–Reims 30N22;
7. –;
8. 1-30 = T;
9. –;
10. ST;
11. –;
12. –;
13. 001: New York/24–Paris/PT3 B1,
002: New York/24–Paris/PT3 B2,
.....
090: New York/24–Paris/PT3 B90.

A.4.5 Full example for the designation of an international Virtual Container

NOTE – The numbers between parentheses refer to the numbers of the items in the Related information.

The international Virtual Container is the 12th VC-4 between Roma and Paris. The urgency for restoration (1) is 2, the terminal countries (2) are France and Italy, the Administrations involved (3) are France Telecom and ASST, control station (4) is Roma 1 and sub-control station is Paris Archives, the fault report points (5) are the same stations, the block has been routed (6) in the multiplex section Paris-Roma 4S2 on position number 3, it has no associated block (7), no special equipment (8) is involved, the use of the block (9) is unknown, no satellite is involved (10), no end-to-end information (11) is required, the bit rate (12) is 155 Mbit/s, the occupancy (13) is seen in the example and the access points (14) are shown there as well.

Designation:

Paris–Roma VC4S12

Related Information:

1. 2;
2. FRA, ITA;
3. FRATEL, ASST;
4. CS: Roma/1,
SCS1: Paris/ARC;
5. Paris/ARC, Roma/1;
6. Paris–Roma 4S2/3;
7. –;
8. –;

Superseded by a more recent version

9. –;
10. –;
11. –;
12. –;
13. 1,0,0: Napoli–Paris VC3S15,
2,1,0: Lille–Roma VC2S8,
2,2,0: Lille–Roma VC2S121,
2,3,0: –,
2,4,1: London–Roma VC12S30,
2,4,2: Paris–Roma VC12S4,
2,4,3: London–Roma VC12S31,
2,5,0: London–Roma VC2S67,
2,6,0: –,
2,7,0: Paris–Roma VC2S82,
3,0,0: Napoli–Paris VC3S16;
14. APIdA: FRAFT123456789,
APIdB: ITATI987654321.

A.4.6 Full example for the designation information of an international multiplex section

NOTE – The numbers between parentheses refer to the numbers of the items in the Related information.

The international multiplex section is the first STM-4 between London and Paris. The urgency for restoration (1) is 1, the terminal countries (2) are United Kingdom and France, the Administrations involved (3) are British Telecom International and France Telecom, the control and sub-control stations (4) are London Mollison and Paris Archives respectively, the fault report points (5) are the same stations, the system has been routed (6) on the France-UK 4 submarine cable, there is no information to be recorded about association (7), equipment information (8) and use (9), there is no satellite involved (10), item (11) does not apply, the bit rate (12) is 620 Mbit/s, the occupancy (13) is seen in the example.

Designation:

London–Paris 4S1

Related Information:

1. 1;
2. GBR, FRA;
3. BT, FRATEL;
4. CS: London/SM,
SCS1: Paris/ARC
5. London/SM, Paris/ARC;
6. France–UK 4;
7. –;
8. –;
9. –;

Superseded by a more recent version

10. –;
11. –;
12. 620 Mbit/s;
13. 1: Glasgow–Paris VC4S12,
2: London–Paris VC4S21,
3: –,
4: London–Toulouse VC4S2;
14. APId 441234567890123,
APId FRAFT987654321.

ANNEX B

KLM addressing and its relationship to time slot numbering for virtual containers

B.1 KLM addressing relationship to time slot numbering

It is possible to relate VC-4 occupancy listing with time slot numbering or tributary numbering to an occupancy listing with KLM addressing by using the following process.

- List the designations of all tributaries (irrespective of type) in order. This will consist of a possible combination of VC-12s, VC-2s and/or VC-3s.
- *Assign a K number:*
Every VC-*n* is contained in one of three TU3s (or TUG3s). Each VC-*n* tributary should be assigned a K number, from 1 to 3, corresponding to the position in which its TU3 (or TUG3) is contained within the VC-4, e.g. the VC-3 in the second TU3 has a K number of 2; any VC-12 in the third TU3 has a K number of 3, etc.
- *Assign an L number:*
For each VC-3, the L number is 0.
Each VC-2 or VC-12 is contained within one of seven TU2s (or TUG2s) within a TUG3. Each VC-2 or VC-12 should be assigned an L number from 1 to 7, corresponding to the position in which its TU2 (or TUG2) is contained within its TU3, e.g. a VC-2 in the fifth TU2 within its TUG3 has an L number of 5; any VC-12 within the sixth TUG2 in a TUG3 has an L number of 6, etc.
- *Assign an M number:*
For each VC-3 and VC-2, the M number is 0.

Each VC-12 is contained within one of three TU12s within a TUG2. Each VC-12 should be assigned an M number from 1 to 3, corresponding to the position in which its TU12 is contained within its TUG2, e.g. the VC-12 corresponding to the third TU12 within a TUG2 has an M number of 3.

B.2 KLM addressing of VC4 occupancy

The following Figure B.1 illustrates VC-3, VC-2 and VC-12 occupancy of a VC-4.

Superseded by a more recent version

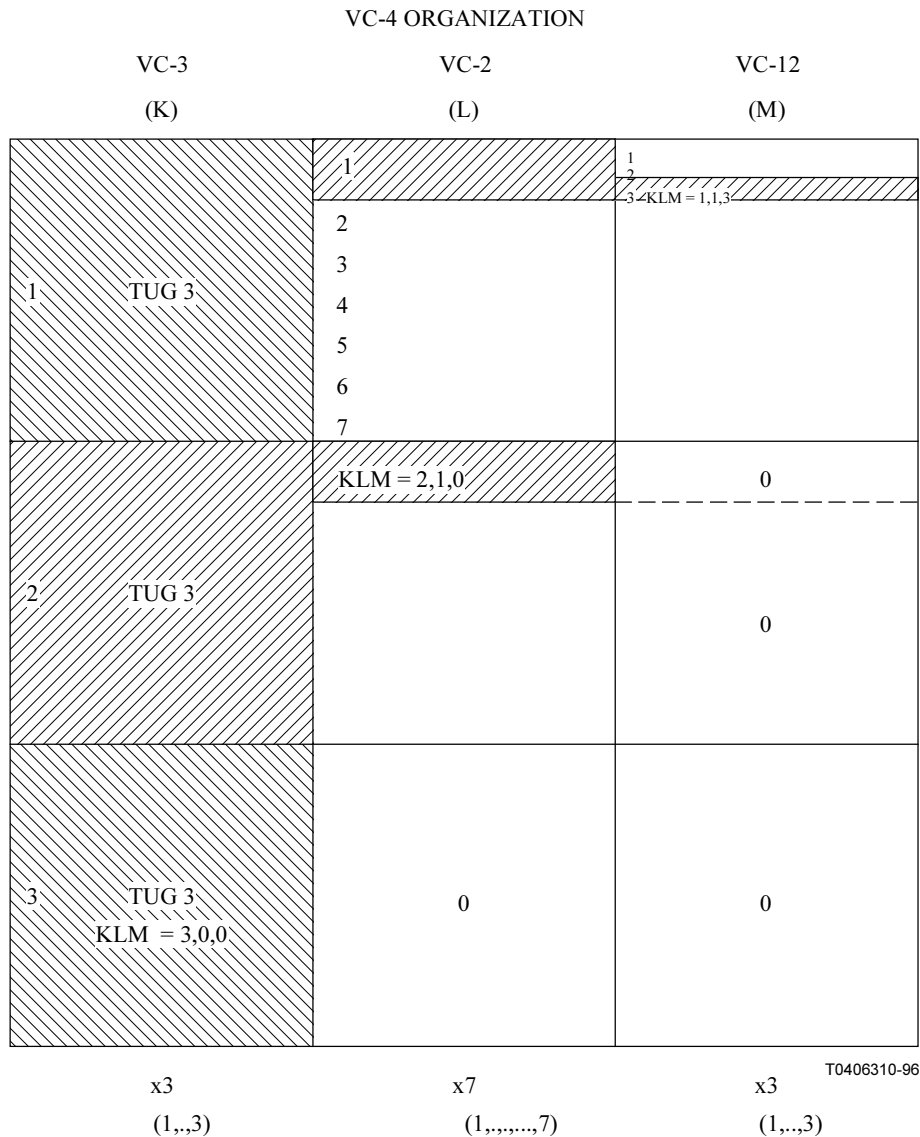

Figure B.1/M.1400 – VC-4 organization

B.3 Comparative notation of KLM addressing vs. time slot numbering

The following example shows the two alternative ways of presenting occupancy. List 1 shows an occupancy listing using KLM numbering. List 2 shows the corresponding occupancy using time slot numbering. Note that each KLM address is specified only once in list 1. Also note that in list 2 a VC-3 (n,0,0) is repeated at every third time slot; a VC-2, (n,n,0) is repeated at every 21st time slot: a VC-12 (n,n,n) is not repeated within the 63 time slots.

Superseded by a more recent version

List 1	List 2
Using KLM Addressing	Using Time Slot Numbering
1,0,0: Napoli–Paris VC3S15, 2,1,0: Lille–Roma VC2S8, 2,2,0: Lille–Roma VC2S66, 2,3,0: –, 2,4,1: London–Roma VC12S30, 2,4,2: Paris–Roma VC12S44, 2,4,3: London–Roma VC12S31, 2,5,0: Lille–Roma VC2S67, 2,6,0: –, 2,7,0: Paris–Roma VC2S82, 3,0,0: Napoli–Paris VC3S16;	01:Napoli–Paris VC3S15, 02:Lille–Roma VC2S8, 03:Napoli–Paris VC3S16, 04:Napoli–Paris VC3S15, 05:Lille–Roma VC2S66, 06:Napoli–Paris VC3S16, 07:Napoli–Paris VC3S15, 08:–, 09:Napoli–Paris VC3S16, 10:Napoli–Paris VC3S15, 11:London–Roma VC12S30, 12:Napoli–Paris VC3S16, 13:Napoli–Paris VC3S15, 14:Lille–Roma VC2S67, 15:Napoli–Paris VC3S16, 16:Napoli–Paris VC3S15, 17:–, 18:Napoli–Paris VC3S16, 19:Napoli–Paris VC3S15, 20:Paris–Roma VC2S82, 21:Napoli–Paris VC3S16, 22:Napoli–Paris VC3S15, 23:Lille–Roma VC2S8, 24:Napoli–Paris VC3S16, 25:Napoli–Paris VC3S15, 26:Lille–Roma VC2S66, 27:Napoli–Paris VC3S16, 28:Napoli–Paris VC3S15, 29:–, 30:Napoli–Paris VC3S16, 31:Napoli–Paris VC3S15, 32:Paris–Roma VC12S44, 33:Napoli–Paris VC3S16, 34:Napoli–Paris VC3S15, 35:Lille–Roma VC2S67, 36:Napoli–Paris VC3S16, 37:Napoli–Paris VC3S15, 38:–, 39:Napoli–Paris VC3S16, 40:Napoli–Paris VC3S15, 41:Paris–Roma VC2S82, 42:Napoli–Paris VC3S16, 43:Napoli–Paris VC3S15, 44:Lille–Roma VC2S8, 45:Napoli–Paris VC3S16,

Superseded by a more recent version

List 1	List 2
Using KLM Addressing	Using Time Slot Numbering
	46:Napoli–Paris VC3S15, 47:Lille–Roma VC2S66, 48:Napoli–Paris VC3S16, 49:Napoli–Paris VC3S15, 50:–, 51:Napoli–Paris VC3S16, 52:Napoli–Paris VC3S15, 53:London–Roma VC12S31, 54:Napoli–Paris VC3S16, 55:Napoli–Paris VC3S15, 56:Lille–Roma VC2S67, 57:Napoli–Paris VC3S16, 58:Napoli–Paris VC3S15, 59:–, 60:Napoli–Paris VC3S16, 61:Napoli–Paris VC3S15, 62:Paris–Roma VC2S82, 63:Napoli–Paris VC3S16;

ANNEX C

Reference subclause numbers for the various types of routes

<i>Subclause</i>	<i>Type of international route</i>
1.2.2	Telephone circuits used in manual operation
1.2.3	One-way telephone circuits used for semi-automatic or automatic operation
1.2.4	Both-way telephone circuits used for semi-automatic or automatic operation
1.3	Circuits used for switched telex and telegraph service
1.4	Circuits in the international public switched data network
3.2.2	Analogue leased circuit used for telephony
3.2.3.1	Analogue circuits used for voice-frequency telegraphy
3.2.3.2	Analogue leased circuits used for TDM-telegraphy
3.2.4	Leased telegraph circuits
3.2.5	Analogue leased circuits used for data transmission
3.2.6	Analogue leased circuits used for phototelegraphy or facsimile
3.2.7.1	Analogue leased unidirectional sound-programme transmission circuits
3.2.7.2	Analogue leased reversible sound-programme transmission circuits
3.2.8.1	Analogue leased unidirectional television-programme circuits
3.2.8.2	Analogue leased reversible television-programme circuits
3.2.9	Leased circuits used for digital video transmission
3.2.10	Analogue leased circuits connecting circuit multiplication terminal equipment at renters' premises
3.2.11	Analogue leased circuits used for combinations of transmissions, etc.

Superseded by a more recent version

- 3.2.12 Analogue leased circuits connecting three or more locations
- 3.2.13 Leased analogue groups, supergroups, etc.
- 3.2.14 Leased analogue group, supergroup links
- 3.2.15 Digital leased circuits connecting two locations
- 3.2.16 Digital leased circuits connecting three or more locations
- 3.3.2.1 Public circuits used for unidirectional sound-programme transmission
- 3.3.2.2 Public circuits used for reversible sound-programme transmission
- 3.3.2.3 Public circuits used for narrow-band sound-programme transmission
- 3.3.3.1 Public circuits used for unidirectional television transmission
- 3.3.3.2 Public circuits used for reversible television transmission
- 3.3.4 Public circuits for digital audio and video transmission
- 3.3.5 Public telephone-type circuits used for phototelegraphy or facsimile
- 3.3.6 Telephone-type circuits used to provide voice-frequency telegraph links
- 3.3.7 Telephone-type circuits used to provide time division multiplex telegraph systems
- 3.3.8 Telephone-type circuits used for data transmission
- 3.3.9 Telephone-type circuits used as transfer links for common channel signalling systems
Nos. 6 and 7
- 5.2.1 Groups (bidirectional)
- 5.2.2 Supergroups (bidirectional)
- 5.2.3 Mastergroups (bidirectional)
- 5.2.4 Supermastergroup (bidirectional)
- 5.2.6 Restoration groups and supergroups (bidirectional)
- 5.3.1 Multiple destination unidirectional groups and supergroups
- 5.3.2 Single destination unidirectional groups and supergroups
- 6.1.1 Conventional group and supergroup links
- 6.1.2 Restoration links
- 6.2 Line links
- 8.2 Bidirectional digital blocks
- 8.3 Restoration digital blocks
- 8.4 Multiple destination unidirectional digital blocks
- 8.5 Single destination unidirectional digital blocks
- 9.1 Conventional digital paths
- 9.2 Restoration digital paths
- 10.1.1 Groups and supergroups, etc. on a mixed analogue/digital route
- 10.1.2 Digital blocks and paths on a mixed analogue/digital route
- 10.2 Routes with two analogue-to-digital conversions
- 11.1 Data transmission systems
- 11.2 Data transmission links
- 12 Blocks created by interconnection of DCMEs
- 13 Virtual containers

Superseded by a more recent version

- 14 Multiplex sections (SDH)
- 16 Asynchronous Transport Mode (ATM)

References

- [1] CCITT Recommendation B.13 (Appendix II) (1988), *General terminology of telecommunications (Terms common to CCIR and CCITT)* and CCITT Recommendation Q.9 (1988), *Vocabulary of switching and signalling terms*.
- [2] ISO 3166:1993, *Codes for the representation of names of countries*.
- [3] CCITT Recommendation R.70 (1984), *Designation of international telegraph circuits*.
- [4] CCITT Recommendation M.1055 (1988), *Lining up an international multiterminal leased circuit*.
- [5] CCITT Recommendation M.1012 (1988), *Circuit control station for leased and special circuits*.
- [6] CCITT Recommendation M.1013 (1988), *Sub-control station for leased and special circuits*.
- [7] ITU-T Recommendation M.1045 (1996), *Preliminary exchange of information for the provision of international leased circuits and international data transmission systems*.
- [8] CCITT Recommendation Q.8 (1988), *Signalling systems to be used for international manual and automatic working on analogue leased circuits*.
- [9] ITU-T Recommendation M.1020 (1993), *Characteristics of special quality international leased circuits with special bandwidth conditioning*.
- [10] CCITT and ITU-T Recommendations G.731 to G.755, concerning the *Principal characteristics of primary, second order and higher order digital multiplex equipment*.
- [11] ITU-T Recommendation G.113 (1996), *Transmission impairments*.
- [12] CCITT Recommendation E.171 (1988), *International telephone routing plan*.
- [13] CCITT Recommendation G.702 (1988), *Digital hierarchy bit rates*.
- [14] CCITT Recommendation G.811 (1988), *Timing requirements at the outputs of primary reference clocks suitable for plesiochronous operation of international digital links*.
- [15] CCITT Recommendation M.80 (1988), *Control stations*.
- [16] CCITT Recommendation M.90 (1988), *Sub-control stations*.
- [17] CCITT Recommendation M.1510 (1992), *Exchange of contact point information for the maintenance of international services and the international network*.
- [18] CCITT Recommendation M.2130 (1992), *Operational procedures in locating and clearing transmission faults*.
- [19] CCITT Recommendation M.20 (1992), *Maintenance philosophy for telecommunications networks*.
- [20] ITU-T Recommendation G.707 (1996), *Network node interface for the Synchronous Digital Hierarchy (SDH)*.
- [21] CCITT Recommendation V.29 (1988), *9600 bits per second modem standardized for use on point-to-point 4-wire leased telephone-type circuits*.

Superseded by a more recent version

- [22] ITU-T *List of International Carrier Codes* as published periodically in the ITU-T Operational Bulletin.
- [23] ITU-T Recommendation E.164 (1997), *The international public telecommunication numbering plan*.
- [24] ITU-T Recommendation M.60 (1993), *Maintenance terminology and definitions*.
- [25] ITU-T Recommendation G.831 (1996), *Management capabilities of transport networks based on the Synchronous Digital Hierarchy (SDH)*.

ANNEX D

Alphabetical list of abbreviations used in this Recommendation

ADPCM	Adaptative differential pulse code modulation
AP	Access Point
ATM	Asynchronous Transfer Mode
BC	Bearer Circuit
CIC	Circuit Identification Code
CO	Compandor
CS	Control Station
CTE	Channel Translating Equipment
DC	Derived Circuit
DCME	Digital Circuit Multiplication Equipment
EC	Echo Canceller
EP	Even Position
ES	Echo Suppressor
GTE	Group Translating Equipment
IE	International Exchange
ISPC	International Signalling Point Code
LRE	Low Rate Encoding
OP	Odd Position
PLR	Part of a Longer Route
SCS	Subcontrol Station
SDH	Synchronous Digital Hierarchy
SGTE	Supergroup Translating Equipment
SI	Speech Interpolation
TDM	Time Division Multiplex
VC	Virtual Container
VC-n	Virtual Container- <i>n</i>

Superseded by a more recent version

ANNEX E

Numbering of channels in data transmission systems

Using suitable modems and multiplexers, it is possible to provide for a combination of data channels multiplexed together to form an aggregate bit rate for data transmission purposes.

The principle shown in Figure E.1 and Table E.1 may be applied to higher bit rates as modems, etc. are developed and deployed.

The numbering of data channels is obtained by indicating the multiplex channel followed by the sub-channel data rate assigned number in accordance with the scheme contained in Table E.1.

As an example, Figure E.1 shows a data transmission system, London–Montreal 96H001, employing equipment providing for 2 channels at 2400 bit/s and one channel at 4800 bit/s, forming an aggregate bit rate of 9600 bit/s.

London–Montreal 96H001/A2

London–Montreal 96H001/B1

London–Montreal 96H001/C1

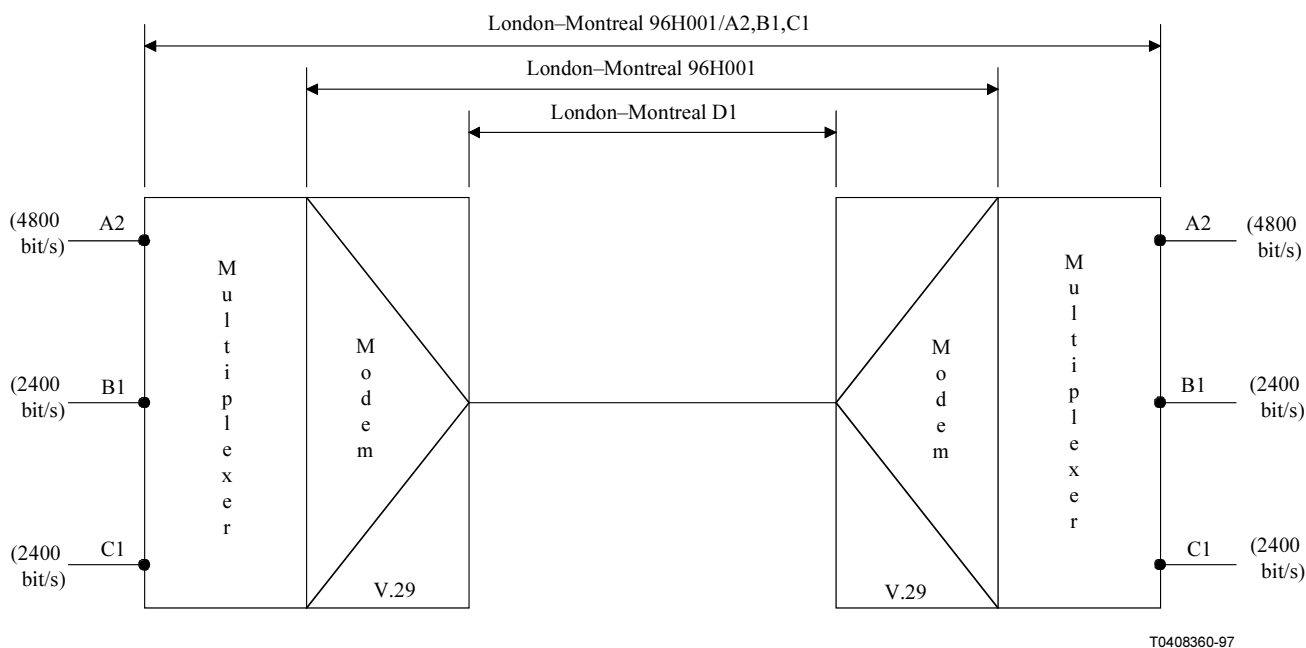

Figure E.1/M.1400 – Example of the channel numbering scheme for data transmission systems

Table E.1 shows the channel numbering scheme for data transmission systems operated at an aggregate data rate of 9600 bits/s. The table also shows the channel numbering scheme for systems using 9600 bit/s modems operated at reduced rates of 7200 bit/s or 4800 bit/s.

Superseded by a more recent version

Table E.1/M.1400 – Channel numbering scheme for data transmission systems using 9600 bit/s data modems conforming to Recommendation V.29 [21]

Aggregate data rate	Multiplex configuration	Sub-channel data rate	Multiplex channel	Channel number
9600 bit/s	1	9600	A	A4
	2	7200	A	A3
		2400	B	B1
	3	4800	A	A2
		4800	B	B2
4	4800	2400	A	A2
		2400	B	B1
		2400	C	C1
5	2400	2400	A	A1
		2400	B	B1
		2400	C	C1
		2400	D	D1
7200 bit/s	6	7200	A	A3
	7	4800	A	A2
		2400	B	B1
8	2400	2400	A	A1
		2400	B	B1
		2400	C	C1
4800 bit/s	9	4800	A	A2
	10	2400	A	A1
2400		B	B1	

Sub-channel data rate	Assigned number
9600	4
7200	3
4800	2
2400	1

Superseded by a more recent version

ITU-T RECOMMENDATIONS SERIES

Series A	Organization of the work of the ITU-T
Series B	Means of expression: definitions, symbols, classification
Series C	General telecommunication statistics
Series D	General tariff principles
Series E	Overall network operation, telephone service, service operation and human factors
Series F	Non-telephone telecommunication services
Series G	Transmission systems and media, digital systems and networks
Series H	Audiovisual and multimedia systems
Series I	Integrated services digital network
Series J	Transmission of television, sound programme and other multimedia signals
Series K	Protection against interference
Series L	Construction, installation and protection of cables and other elements of outside plant
Series M	TMN and network maintenance: international transmission systems, telephone circuits, telegraphy, facsimile and leased circuits
Series N	Maintenance: international sound programme and television transmission circuits
Series O	Specifications of measuring equipment
Series P	Telephone transmission quality, telephone installations, local line networks
Series Q	Switching and signalling
Series R	Telegraph transmission
Series S	Telegraph services terminal equipment
Series T	Terminals for telematic services
Series U	Telegraph switching
Series V	Data communication over the telephone network
Series X	Data networks and open system communication
Series Z	Programming languages