

I n t e r n a t i o n a l T e l e c o m m u n i c a t i o n U n i o n

ITU-T

TELECOMMUNICATION
STANDARDIZATION SECTOR
OF ITU

M.3020

(09/2010)

SERIES M: TELECOMMUNICATION MANAGEMENT,
INCLUDING TMN AND NETWORK MAINTENANCE

Telecommunications management network

**Management interface specification
methodology**

Recommendation ITU-T M.3020



ITU-T M-SERIES RECOMMENDATIONS

TELECOMMUNICATION MANAGEMENT, INCLUDING TMN AND NETWORK MAINTENANCE

Introduction and general principles of maintenance and maintenance organization	M.10–M.299
International transmission systems	M.300–M.559
International telephone circuits	M.560–M.759
Common channel signalling systems	M.760–M.799
International telegraph systems and phototelegraph transmission	M.800–M.899
International leased group and supergroup links	M.900–M.999
International leased circuits	M.1000–M.1099
Mobile telecommunication systems and services	M.1100–M.1199
International public telephone network	M.1200–M.1299
International data transmission systems	M.1300–M.1399
Designations and information exchange	M.1400–M.1999
International transport network	M.2000–M.2999
Telecommunications management network	M.3000–M.3599
Integrated services digital networks	M.3600–M.3999
Common channel signalling systems	M.4000–M.4999

For further details, please refer to the list of ITU-T Recommendations.

Recommendation ITU-T M.3020

Management interface specification methodology

Summary

Recommendation ITU-T M.3020 describes the management interface specification methodology (MISM). It describes the process to derive interface specifications based on user requirements, analysis and design (RAD). Guidelines are given on RAD using unified modelling language (UML) notation; however, other interface specification techniques are not precluded. The guidelines for using UML are described at a high level in this ITU-T Recommendation.

History

Edition	Recommendation	Approval	Study Group
1.0	ITU-T M.3020	1992-10-05	
2.0	ITU-T M.3020	1995-07-27	4
3.0	ITU-T M.3020	2000-02-04	4
4.0	ITU-T M.3020	2007-07-22	4
5.0	ITU-T M.3020	2008-07-29	4
6.0	ITU-T M.3020	2009-05-14	2
7.0	ITU-T M.3020	2010-09-06	2

FOREWORD

The International Telecommunication Union (ITU) is the United Nations specialized agency in the field of telecommunications, information and communication technologies (ICTs). The ITU Telecommunication Standardization Sector (ITU-T) is a permanent organ of ITU. ITU-T is responsible for studying technical, operating and tariff questions and issuing Recommendations on them with a view to standardizing telecommunications on a worldwide basis.

The World Telecommunication Standardization Assembly (WTSA), which meets every four years, establishes the topics for study by the ITU-T study groups which, in turn, produce Recommendations on these topics.

The approval of ITU-T Recommendations is covered by the procedure laid down in WTSA Resolution 1.

In some areas of information technology which fall within ITU-T's purview, the necessary standards are prepared on a collaborative basis with ISO and IEC.

NOTE

In this Recommendation, the expression "Administration" is used for conciseness to indicate both a telecommunication administration and a recognized operating agency.

Compliance with this Recommendation is voluntary. However, the Recommendation may contain certain mandatory provisions (to ensure, e.g., interoperability or applicability) and compliance with the Recommendation is achieved when all of these mandatory provisions are met. The words "shall" or some other obligatory language such as "must" and the negative equivalents are used to express requirements. The use of such words does not suggest that compliance with the Recommendation is required of any party.

INTELLECTUAL PROPERTY RIGHTS

ITU draws attention to the possibility that the practice or implementation of this Recommendation may involve the use of a claimed Intellectual Property Right. ITU takes no position concerning the evidence, validity or applicability of claimed Intellectual Property Rights, whether asserted by ITU members or others outside of the Recommendation development process.

As of the date of approval of this Recommendation, ITU had not received notice of intellectual property, protected by patents, which may be required to implement this Recommendation. However, implementers are cautioned that this may not represent the latest information and are therefore strongly urged to consult the TSB patent database at <http://www.itu.int/ITU-T/ipr/>.

© ITU 2011

All rights reserved. No part of this publication may be reproduced, by any means whatsoever, without the prior written permission of ITU.

CONTENTS

	Page
1 Scope	1
2 References.....	1
3 Definitions	2
3.1 Terms defined elsewhere.....	2
3.2 Terms defined in this Recommendation.....	2
4 Abbreviations.....	3
5 Conventions	4
6 Requirements for methodology and notational support.....	4
7 Methodology.....	5
7.1 General considerations	5
7.2 Application and structure of the methodology	5
7.3 Detailed methodology	5
8 Management interface specifications	8
9 Traceability in MISM process	8
10 Documentation structure.....	8
Annex A – Requirements.....	9
A.1 Conventions	9
A.2 Requirements template	12
A.3 Simplified requirements template.....	15
Annex B – Analysis	17
B.1 Conventions	18
B.2 Analysis template	20
B.3 IOC properties and inheritance.....	32
Annex C – MISM UML repertoire	34
C.1 Introduction	34
C.2 Basic model elements.....	34
C.3 Stereotypes	37
C.4 Association classes	44
C.5 Abstract class.....	44
C.6 Application of <<InformationObjectClass>> and <SupportIOC>>	45
Annex D – Design.....	46
Annex E – Information type definitions – type repertoire	47
E.1 Basic types.....	47
E.2 Enumerated type.....	47
E.3 Complex types.....	47
E.4 Useful types	47

	Page
E.5 Keywords.....	48
Annex F – Guidelines on IOC properties, inheritance and entity import	49
F.1 IOC property.....	49
F.2 Inheritance	50
F.3 Entity (interface, IOC and attribute) import	50
Appendix I – Requirements example.....	51
Appendix II – Analysis example.....	54
Appendix III – Comparison with Recommendation ITU-T Z.601	62
Appendix IV – Issues for further study.....	63
IV.1 SOA	63
IV.2 UML	63
IV.3 Visibility	63
IV.4 Type definitions.....	63
Appendix V – Additional UML usage samples	64
V.1 Proxy class.....	64
Appendix VI – Guidelines on requirements numbering	66
Bibliography.....	67

Recommendation ITU-T M.3020

Management interface specification methodology

1 Scope

This Recommendation describes the management interface specification methodology (MISM). It describes the process to derive machine-machine interface specifications based on user requirements, analysis and design (RAD). Guidelines are given on RAD using unified modelling language (UML) notation; however, other interface specification techniques are not precluded. The guidelines for using UML are described in this Recommendation. An interface specification addresses management service(s) defined in [ITU-T M.3200] and/or supporting the management processes defined in [ITU-T M.3050.x] series. Such a specification may support part of or one or more management services. The management services comprise of management functions. These functions may reference those defined in [ITU-T M.3400] or the processes defined in [ITU-T M.3050.x] series, specialized to suit a specific managed area, or new functions may be identified as appropriate.

The methodology is applicable to both the traditional manager/agent style of management interfaces [ITU-T M.3010] and the service oriented architecture (SOA) principles adopted for the management architecture of next generation networks [ITU-T M.3060].

2 References

The following ITU-T Recommendations and other references contain provisions which, through reference in this text, constitute provisions of this Recommendation. At the time of publication, the editions indicated were valid. All Recommendations and other references are subject to revision; users of this Recommendation are therefore encouraged to investigate the possibility of applying the most recent edition of the Recommendations and other references listed below. A list of the currently valid ITU-T Recommendations is regularly published. The reference to a document within this Recommendation does not give it, as a stand-alone document, the status of a Recommendation.

- [ITU-T M.3010] Recommendation ITU-T M.3010 (2000), *Principles for a telecommunications management network*.
- [ITU-T M.3050.x] Recommendation ITU-T M.3050.x (2007), *enhanced Telecom Operations Map (eTOM)*.
- [ITU-T M.3060] Recommendation ITU-T M.3060/Y.2401 (2006), *Principles for the management of next generation networks*.
- [ITU-T M.3200] Recommendation ITU-T M.3200 (1997), *TMN management services and telecommunications managed areas: Overview*.
- [ITU-T M.3400] Recommendation ITU-T M.3400 (2000), *TMN management functions*.
- [ITU-T Q.812] Recommendation ITU-T Q.812 (2004), *Upper layer protocol profiles for the Q and X interfaces*.
- [ITU-T X.680] Recommendation ITU-T X.680 (2008) | ISO/IEC 8824-1:2008, *Information technology – Abstract Syntax Notation One (ASN.1): Specification of basic notation*.
- [ITU-T X.681] Recommendation ITU-T X.681 (2008) | ISO/IEC 8824-2:2008, *Information technology – Abstract Syntax Notation One (ASN.1): Information object specification*.

- [ITU-T X.722] Recommendation ITU-T X.722 (1992) | ISO/IEC 10165-4:1992, *Information technology – Open Systems Interconnection – Structure of management information: Guidelines for the definition of managed objects*.
- [ITU-T Z.100] Recommendation ITU-T Z.100 (2007), *Specification and Description Language (SDL)*.
- [OMG UML] OMG: *Unified Modelling Language Specification, Version 1.5*.

A list of non-normative references can be found in the Bibliography.

3 Definitions

3.1 Terms defined elsewhere

This Recommendation uses the following terms from [ITU-T M.3010]:

- user;
- management service;
- management function set.

This Recommendation uses the following terms from [OMG UML]:

- activity diagram;
- actor;
- association;
- class;
- class diagram;
- classifier;
- collaboration diagram;
- composition;
- modelElement;
- sequence diagram;
- state diagram;
- stereotype;
- use case.

This Recommendation uses the following term from [ITU-T M.3060]:

- reference point.

3.2 Terms defined in this Recommendation

This Recommendation defines the following terms:

3.2.1 agent: Encapsulates a well-defined subset of management functionality. It interacts with managers using a management interface. From the manager's perspective, the agent behaviour is only visible via the management interface.

NOTE – Considered equivalent to IRPAgent [b-3GPP TS 32.150].

3.2.2 information object class: Describes the information that can be passed/used in management interfaces and is modelled using the stereotype "Class" in the UML meta-model. For a formal definition of information object class and its structure of specification, see Annex B.

3.2.3 information type: Specification of the type of input parameters of operations.

3.2.4 information service: Describes the information related to the entities (either network resources or support objects) to be managed and the way that the information may be managed for a certain functional area. Information services are defined for all IRPs.

NOTE – Considered identical to the definition of information service found in [b-3GPP TS 32.150].

3.2.5 integration reference point: An architectural concept that is described by a set of specifications for the definition of a certain aspect of the management interface, comprising a requirements specification, an information service specification, and one or more solution set specifications.

NOTE – Considered identical to the definition of IRP found in [b-3GPP TS 32.150].

3.2.6 management goals: High-level objectives of a user in performing management activities.

3.2.7 management interface: The realization of management capabilities between a manager and an agent, allowing a single manager to use multiple agents and a single agent to support multiple managers.

NOTE – Q, C2B/B2B and Itf-N (3GPP) are examples of management interfaces.

3.2.8 management role: Defines the activities that are expected of the operational staff or systems that perform telecommunications management. Management roles are defined independent of other components, i.e., telecommunications resources and management functions.

3.2.9 management scenario: A management scenario is an example of management interactions from a management service.

3.2.10 manager: Models a user of agent(s) and it interacts directly with the agent(s) using management interfaces.

Since the manager represents an agent user, it gives a clear picture of what the agent is supposed to do. From the agent perspective, the manager behaviour is only visible via the management interface.

NOTE – Considered equivalent to IRPManager [b-3GPP TS 32.150].

3.2.11 matching information: Specification of the type of a parameter (possibly reference to IOC or attribute of IOC).

3.2.12 protocol-neutral specification: Defines the management interfaces in support of management capabilities without concern for the protocol and information representation implied or required by, e.g., CORBA and XML.

3.2.13 protocol-specific specification: Defines the management interfaces in support of management capabilities for one specific choice of management technology (e.g., CORBA).

NOTE – Considered equivalent to solution set [b-3GPP TS 32.150].

3.2.14 telecommunications resources: Telecommunications resources are physical or logical entities requiring management, using management services.

4 Abbreviations

This Recommendation uses the following abbreviations:

3GPP	3rd Generation Partnership Project
ADM	Administrative (usage: requirements category)
ASN.1	Abstract Syntax Notation One
CM	Conditional-Mandatory
CO	Conditional-Optional

CON	Conceptual (usage: requirements category)
CORBA	Common Object Request Broker Architecture
FUN	Functional (usage: requirements category)
GDMO	Guidelines for the Definition of Managed Objects
IDL	Interface Definition Language
IOC	Information Object Class
IRP	Integration Reference Point
IS	Information Service
MISM	Management Interface Specification Methodology
NA	Not Applicable
NE	Network Element
NON	Non-functional (usage: requirements category)
OMG	Object Management Group
OO	Object Oriented
OSI	Open Systems Interconnection
SDL	Specification and Description Language
SOA	Service Oriented Architecture
SS	Solution Set
TS	Technical Specification
UML	Unified Modelling Language
XML	eXtensible Markup Language

5 Conventions

Clause A.1 contains conventions applicable to the requirements phase.

Clause B.1 contains conventions applicable to the analysis phase.

6 Requirements for methodology and notational support

In developing the methodology and choosing a notation, the following requirements apply:

- 1) The methodology, including the choice of notation, shall support the capture of all the relevant requirements of the problem space, namely telecommunications management.
- 2) The methodology facilitates the production of requirements, its corresponding Analysis|Information Services and their corresponding Design Specifications|Solution Sets.
- 3) The notation shall facilitate unambiguous generation of the specification in the target management protocol profile. The methodology does not address possible choices of protocol services (e.g., CORBA Security Service).
NOTE – Management protocols applicable for ITU-T use are specified in [ITU-T Q.812].
- 4) The methodology shall allow specification of mandatory and optional items in all three phases. It also specifies the relation of mandatory|optional items between the three phases.

- 5) It should be possible to generate, from the protocol-neutral specification (Analysis|IS), interoperable language specific definitions, i.e., Design|SS (for example UML to IDL, UML to GDMO/ASN.1).

7 Methodology

7.1 General considerations

The purpose of this methodology is to provide a description of the processes leading towards the definition of machine-machine management interfaces.

7.2 Application and structure of the methodology

The management interface specification methodology (MISM) specifies a three-phase process with features that allow traceability across the three phases. The three phases apply industry-accepted techniques using object oriented analysis and design principles. The three phases are requirements, analysis and design. The techniques should allow the use or development of commercially available support tools. Different techniques may be used for the phases depending on the nature of the problem.

7.3 Detailed methodology

7.3.1 General

The requirements and analysis phases produce UML specifications. The design phase uses network management paradigm specific notation. The outputs of the 3 phases are:

- Requirements phase – Requirements.
- Analysis phase – Implementation independent specification.
- Design phase – Technology specific specification.

Initially, the design phase will be developed using a manual or customized approach. When interoperable protocol specific definition can be generated by tools, then UML notation can be applied to the design phase.

The clauses below describe the three phases.

7.3.2 Requirements

The requirements for the problem being solved fall into two classes. The first class of requirements is referenced here as business requirements. A subject matter expert on the topic shall be able to determine that the requirements adequately represent the needs of the management problem being solved. The second class is referred to as specification requirements. These requirements shall provide sufficient details so that the interface definition in the analysis and design phases can be developed. As final interface definitions must be traceable to the requirements, it may be necessary to have interaction between the three phases. Any ambiguity in the requirements will have to be resolved by this interaction to assure that an implementable specification can be developed.

Human-computer interface data may be specified in the second class of requirements. These requirements may have great impact on concepts and data designed in the subsequent phases. For more detail, see Appendix III, and see the ITU-T M.1400-series Recommendations on data design for human-computer interfaces.

Different techniques may be used to specify the two classes of requirement. Irrespective of the technique, the readability of the requirements is critical. The requirements themselves are not required to be in a machine-readable notation as long as readability and traceability are possible. Enumerating requirements is the recommended solution to delineate the different requirements for traceability.

The requirements phase includes identifying aspects such as security policy, scope of the problem domain in terms of the applications, resources, and roles assumed by the resources. The requirements specify roles, responsibilities, and the relationships between the constituent entities for the problem space. Different techniques, including textual representation, may be used to specify the business level requirements. In order to facilitate traceability of these requirements to the design and implementation phases, enumerating requirements is recommended.

The problem must be bounded with a specific scope. One way to determine the scope is by using the management services identified in [ITU-T M.3200] and function sets identified in [ITU-T M.3400]. Requirements are specified using the resources being managed and management functions. An alternative to the management services approach is described in [ITU-T M.3050.x] "enhanced Telecom Operations Map (eTOM)" which provides a business process based approach.

The relationship between the ITU-T M.3200 and ITU-T M.3050 approaches is described in [ITU-T M.3050.x].

Management functions must be grouped and supported within applications that address specific business needs, so the linkage between the eTOM processes, the ITU-T M.3200 management services, the ITU-T M.3400 management function sets and management functions is important to assist in making this grouping clear and effective. Augmenting [ITU-T M.3400] may be required in order to meet the business requirements of the problem.

UML use cases and scenarios should be used to interact with subject matter experts in capturing the business level requirements. The requirements should also identify the failure conditions visible to the business process.

NOTE – It is not required that every requirement be expressed as a use case.

The requirements produced must be complete and detailed. The recursive nature of the methodology is used to achieve this completeness. The completeness of the requirements (clear and well-documented) drives the analysis and design phases.

Guidelines and template for requirement structure and identification are described in clause A.1.2.

Use cases are goals that are fulfilled through a sequence of steps. Each step can be considered as a sub-goal of the use case. As such each step represents either another use case (subordinate use case) or an autonomous action that is at the lowest level of the case decomposition.

Guidelines and template for use cases are described in clause A.1.2.

An example requirements definition is available in Appendix I.

7.3.3 Analysis

In the analysis phase, the requirements are used to identify the interacting entities, their properties and the relationships among them. This allows the interfaces offered by the entities to be defined. In the UML notation, these entities become classes. The class descriptions along with the interfaces exposed should be traceable to the requirements. The relationship among the classes, defined in the analysis specification, and the classes in the design specification is not necessarily one to one.

This phase should take into account the needs of human-computer interface data (i.e., the information model must contain sufficient information so that designs can be developed based on the analysis results).

This Recommendation gives high-level guidance on the use of UML notation to support management interface specification; however, SDL [ITU-T Z.100] might be used to augment the UML definitions.

The analysis phase should be independent of design constraints. For example, the analysis may be documented using OO principles even though the design may use a non object-oriented technology. The information specified in the analysis phase includes class descriptions, data definitions, class

relationships, interaction diagrams (sequence diagrams and/or collaboration diagrams), state transition diagrams and activity diagrams. The class definitions include specification of operations, notifications, attributes and behaviour captured as notes or textual description.

Protocol-neutral common management services (if available) – or other existing services – should be reused during the analysis phase in order to support management interface harmonization.

Guidelines and template for use cases are described in Annex A.

The analysis template uses information type as one characteristic to describe IOC attributes and operation/notification parameters. The valid information type(s) that can be used and their semantics are defined in Annex E.

7.3.4 Design

7.3.4.1 General

In the design phase, an implementable interoperable interface specification is produced. This will involve the selection of a target specification language. The design phase specifications are dependent on the specific management paradigm (e.g., IDL for CORBA interfaces).

This phase distinguishes three kinds of specifications of data: management paradigm (e.g., XML) dependent design of data to be communicated across multiple interfaces (e.g., fault and performance), messages (e.g., alarm report) to be communicated over each individual interface, and encoding method of the data (e.g., compressed XML) consistent with a particular paradigm.

The selection of a specific management paradigm is addressed in other ITU-T Recommendations. An overview is provided in the following clauses.

In the design phase, it is recommended that the UML descriptions from the requirements and analysis phases be referenced to augment behavioural specification. For example, behaviour definition of GDMO can reference state charts, sequence diagrams and class definition in the analysis phase. If required, additional UML diagrams describing interactions between entities, corresponding to specific protocol paradigms, may be included.

As additional paradigms are adopted for use by management, the notations/languages defined by these paradigms will be used.

7.3.4.2 CORBA

In the context of CORBA based management, the information model is defined using IDL.

7.3.4.3 GDMO

In the context of the paradigm based on OSI systems management [ITU-T X.722], the design specification is the information model specification using GDMO templates for managed object classes, attributes, behaviour, notifications, actions, naming instances of the class, and error/exception specifications. The syntax of the information is specified using ASN.1 notation [ITU-T X.680].

In GDMO, the object class hierarchy specifies the properties of the object classes that are needed for management. Extensive use of inheritance (super and subclasses) is needed to benefit the most from the reuse of specifications. The object classes are specified using the templates from [ITU-T X.722]. The templates defining the information model should be registered (according to the rules of [ITU-T X.722]) with a value for the ASN.1 object identifier. For those object classes that are already specified in other ITU-T Recommendations and ISO standards, only a reference to the particular Recommendation and object class is needed. Naming is not a part, nor the purpose, of the object class hierarchy.

7.3.4.4 XML

For further study.

8 Management interface specifications

A management interface specification includes the requirements, analysis and design specifications discussed in clause 7. A structure for specifying these specifications is provided in Annexes A, B and C.

These techniques and supporting notations are also applicable when designing a system to the management interface specifications, even though system design is not considered as part of the ITU-T management Recommendations. They assist in describing how the interface specifications are applied in managing the resources within a system such as an NE.

9 Traceability in MISM process

In order to achieve traceability between requirements, analysis and design, it is necessary that appropriate identification be assigned. Traceability is supported through references between entities specified within each phase and between phases. Traceability is from design|solution set to analysis|information services and from analysis|information services to requirements. Traceability is further applicable between artifacts of the requirements specification and between artifacts of the analysis|information service, e.g., between use cases and textual requirements. Requirements should be identified as described in clause 7.3.2. The analysis phase output specifies for the various use cases further detailed information requirements. The design phase should point to the various diagrams and text in the analysis phase output. The pointer may be in terms of a reference to the appropriate sections.

Traceability from the design phase to subject matter level requirements is usually indirect. This is required because the output of the phases is defined to different level of details.

Guidelines for traceability between the requirements phase and the analysis phase are described in Annex B.

The following mechanism for traceability with requirements, etc., specified in other documents (possibly not following the advocated identification schema) is recommended:

forum/body "::" document ID "::" id

where "id" could be one of:

- 1) requirement ID;
- 2) use case ID;
- 3) requirement title/text;
- 4) use case title;
- 5) subsection of the document which uniquely identifies a requirement or use case.

Examples:

3GPP::32.111-1::getAlarmList

ITU-T::M.3016::1.5.1.2

10 Documentation structure

Even though there are three phases, the documentation of the interface may combine their outputs into one or more documents. It is recommended that the requirements and analysis be combined and separate design documents are developed for each specific network management protocol paradigm.

Annex A

Requirements

(This annex forms an integral part of this Recommendation)

- A.1 *Conventions*
 - A.1.1 *Use of UML notation for requirements*
 - A.1.2 *Use case template*
 - A.1.3 *Requirements categories*
- A.2 *Requirements template*
 - 1 *Concepts and background*
 - 2 *Business level requirements*
 - 2.1 *Requirements*
 - 2.2 *Actor roles*
 - 2.3 *Telecommunication resources*
 - 2.4 *High-level use cases*
 - 3 *Specification level requirements*
 - 3.1 *Requirements*
 - 3.2 *Actor roles*
 - 3.3 *Telecommunication resources*
 - 3.4 *Use cases*
- A.3 *Simplified requirements template*
 - 1 *Concepts and background*
 - 2 *Requirements*

The following are guidelines for specification of requirements. An example of the use of this template can be found in Appendix I.

The normal (or full format) requirements template is found in clause A.2. In addition, a simplified requirements template is defined and found in clause A.3.

A.1 Conventions

A.1.1 Use of UML notation for requirements

Table A.1 identifies the correspondence between management concepts and UML notation. This Recommendation specifies the high-level concepts and notations to be used in the different phases. Stereotypes are used to extend UML notation. The approved stereotypes for use within the management environment are included in this Recommendation (see Annex C).

Table A.1 – Requirements concepts

Management concept	UML notation	Comment
user.	Actor	A user is modelled as an actor.
management role.	Actor	An actor plays a role. It is normally advisable to only model a single role for each actor.
management function.	use case	A management function is modelled by one or more use cases.
management function set.	use case	A management function set is a composite use case with each management function (potentially) modelled as a separate use case.
management service.	use case	A management service is modelled as a high-level use case.
management scenario.	sequence diagram	Sequence diagrams are preferred over collaboration diagrams.
telecommunication resource type.	Class	The class diagrams depict the property details of the telecommunications resource type, at the level of detail appropriate to the phase of the methodology.
management goals.	–	Management goals are captured as textual descriptions as there is no applicable UML notation.

A.1.2 Use case template

When use cases are provided, the following conventions and templates should be followed.

Table A.2 – Use case template

Use case stage	Evolution/Specification	<<Uses>> Related use
Goal ^(*)	This is the objective/end result the use case strives to achieve and should be a concise statement of what the use case should achieve in a successful scenario. There may be a statement about priority relative to other use cases and required performance of the use case, e.g.: <ul style="list-style-type: none"> • Real Time. • Near real time. • Not real time. 	
Actors and roles ^(*)	The names of actors/roles involved in the use case including role characteristic for each actor.	
Telecom resources	The names of the telecommunication resources involved in the use case.	
Assumptions	A description of the environment providing a context for the use case. Assumptions are mutually exclusive to pre-conditions. Assumptions are concerned with static properties.	
Pre-conditions	A list of all system and environment conditions that must be true before the use case can be triggered. Pre-conditions are mutually exclusive to assumptions. Pre-conditions are related to dynamic properties and can result in an exception. This is never the case with assumptions.	

Table A.2 – Use case template

Use case stage	Evolution/Specification	<<Uses>> Related use
Begins when	The name of the single event that triggers the start of the use case. Optional and normally not used to specify triggers such as "when the manager must retrieve information".	
Step 1 ^(*) (M O)	A use case describes a list of steps (manual and automated) that are necessary to accomplish the goal of the use case. Steps may invoke other use cases. Steps are numbered for traceability. Each step is identified as being mandatory (M) or optional (O). Sub-steps are identified relative to the containing step, e.g.: Step n Step n.1 Step n.2 where n.1 and n.2 are sub-steps of step n.	Reference to a used use case.
Step n (M O)	Steps added as necessary and in a logical sequence.	
Ends when ^(*)	The list of event(s) that indicates the use case completion. NOTE – In this context, "event" should be considered in the most general sense and not limited to, e.g., notifications exchanged across a management interface. As an example, the completion of processing can be considered an event that indicates completion of a use case.	
Exceptions	A summary list of exception conditions and faults detected by the use case during its operation.	
Post-conditions	A list of all system and environmental conditions that must be true when the use case has completed. The statement of post-conditions determines if the use case is expected to be fully successful, partially successful or even to have failed in order to be completed.	
Traceability ^(*)	Requirements or use case exposed by the use case.	
NOTE – Fields marked with "*" are mandatory for all use case specifications. Other fields are only mandatory when relevant for the specific use case.		

A.1.3 Requirements categories

It is useful to classify requirements in different categories. The following categories are considered relevant for MISM:

- Conceptual (CON) – Identifies a concept, data type, relationship, format, or structure.
- Functional (FUN) – Identifies a functional capability, dynamic situation, a sequence, timing parameters, or an interaction.
- Non-functional (NON) – Non-functional requirements, including abnormal conditions, error conditions and bounds of performance.
- Administrative (ADM) – System administration and operational requirements not related to the use cases normal operations.

Requirements should be written based on the following template:

REQ-Label-Category-Number {Category, number} Details {Source Citation}

where "Label" is an abbreviation for the Recommendation (or part thereof). The set of labels is not finite and not subject for standardization.

Guidelines on requirements numbering can be found in Appendix VI.

A.2 Requirements template

1 Concepts and background

Define major goals and objectives and the applicable management interfaces (and reference points) for this specification. Use [ITU-T M.3200] categorization as a source for identifying the management service(s) supported by this interface.

This subclause should give a clear description of the users' benefit, i.e., the reason for performing this management service. Background and context should be added as necessary, but the explanatory and descriptive parts should be separated. Supporting background information, where required, should be placed in an appendix.

1.a SubSectionTitle

SubSectionTitle is the name of a subclause.

"a" represents a number, starting at 1 and increasing by 1 with each new subclause.

The use of subclauses is optional.

2 Business level requirements

2.1 Requirements

2.1.a SubSetTitle

SubSetTitle is the name of a sub-set of the business level requirements.

"a" represents a number, starting at 1 and increasing by 1 with each new sub-set.

The use of sub-sets is optional and all business level requirements can be stated in clause 2.1 (requirements).

List major requirements in text, and identify use cases with actor/role and resources. The use cases should bring out high-level requirements and are distinguished from the specification requirements by not refining to lower levels. Policy-related information (e.g., security, persistence) are candidates for inclusion at this level. Numbering the requirements is required for traceability.

Requirements should be specified as described in clause A.1.3. Within a requirements specification, it is suggested that requirements are written in the sequence of clause A.1.3 (either for the entire specification or for each sub-set).

Use of requirements categories is optional, and – when used – a subset of the categories can be applied. As an example, conceptual requirement number 23 in Recommendation tagged 'SM' would be specified as follows:

Identifier	Definition
REQ-SM-CON-23	A Service Order consists of a name, address, phone number, service description and an optional FAX number for contacts {T1M1.5 Document 246 11/96}

One or more tables can be used with supportive text between tables as necessary.

2.2 Actor roles

A textual description of the actor (see clause 3) is included here.

2.3 Telecommunication resources

Textual description of the relevant resources (see clause 3) required to support the use cases are presented here.

2.4 High-level use cases

A high-level use case diagram may be presented. In order to understand the use case by subject matter experts, they should be augmented with a textual description for each use case. The description should serve two purposes: to capture the domain experts' knowledge and to validate the models in analysis and design phases with respect to the requirements. An example of a high-level use case diagram is given in Appendix I.

2.4.a UseCaseName

UseCaseName is the name of the use-case.

"a" represents a number, starting at 1 and increasing by 1 with each new definition of a use case.

This clause is repeated for each high-level use case defined for the interface specification requirements. The high-level use cases may identify the various function sets defined in [ITU-T M.3400] or the management processes defined in [ITU-T M.3050.x]. These use cases may be further refined as described in the specification requirement subclause below by using stereotypes such as "include" and "extend".

If appropriate, sequence diagrams may be used. However, at the high-level requirements these diagrams are not expected to be used. When the use cases at this level are further decomposed in the next level of requirements, these diagrams may be more suitable.

The traceability of the next level of requirements from this level may be identified by how each function set is further refined with new use cases.

A set of use case tables, using the template defined in Table A.2, may be used to represent the significant capabilities studied at a level of abstraction appropriate to the problem being analysed.

The level of detail, and extent of coverage provided in the use cases is dependent upon the authoring team's familiarity with the subject matter and is therefore subjective. The lower levels of details are most likely an indication of analysis rather than requirements capture.

It is permitted to develop successively more detailed analysis of each step of a higher abstraction level use case by referring to the more detailed use case in the table cell reserved for this purpose. It is emphasized this does not have to be done, and is subjective depending upon the need of the author/group.

The following list is provided to aid the initial identification of suitable use cases:

- What is the main purpose of the system?*
- What types of people/system need to interact with the system?*

- *How can these people/systems be grouped or abstracted to roles?*
- *What are the start up, normal running, failure and recovery aspects of the system?*
- *What types of reports or data may be needed from the system?*
- *Which special activities are required (e.g., based on times of day and network loads)?*

It is useful to document use cases in a common manner. The following structure is suggested:

- *<use case table> (see Table A.2)*
- *<optional sequence diagram(s)>*
- *<optional state chart(s)>*

3 Specification level requirements

3.1 Requirements

3.1.a SubSetTitle

The high-level use cases are further refined using management functions from [ITU-T M.3400]. Since [ITU-T M.3400] is not exhaustive enough to address all management services for all managed areas, it is expected that new functions will be required. The new functions should be included in the requirements as described below.

Specification level requirements should follow the conventions and templates defined in clause A.1.

3.2 Actor roles

A list of all actors and textual description of actors not already defined in high-level requirements is included here.

3.3 Telecommunication resources

A list of all passive resources and textual description of resources not already defined in high-level requirements is presented here.

3.4 Use cases

3.4.a UseCaseName

UseCaseName is the name of the use-case.

"a" represents a number, starting at 1 and increasing by 1 with each new definition of a use case.

If appropriate, sequence and state chart diagrams may be used.

NOTE – Guidelines and criteria for use of sequence diagrams and state chart diagrams are for further study.

Use case specifications should follow the conventions and templates defined in clause A.1.

A.3 Simplified requirements template

The simplified requirements template is an alternative template for use in cases when only the textual requirements are required. A separate template is defined to avoid ambiguity that would result by adding optionality in the full-form template described in clause A.2.

1 Concepts and background

Define major goals and objectives and the applicable management interfaces (and reference points) for this specification. Use [ITU-T M.3200] categorization as a source for identifying the management service(s) supported by this interface.

This subclause should give a clear description of the users' benefit, i.e., the reason for performing this management service. Background and context should be added as necessary, but the explanatory and descriptive parts should be separated. Supporting background information, where required, should be placed in an appendix.

1.a SubSectionTitle

SubSectionTitle is the name of a subclause.

"a" represents a number, starting at 1 and increasing by 1 with each new subclause.

The use of subclauses is optional.

2 Requirements

2.a SubSetTitle

SubSetTitle is the name of a sub-set of the business level requirements.

"a" represents a number, starting at 1 and increasing by 1 with each new sub-set.

The use of sub-sets is optional and all business level requirements can be stated in clause 2 (requirements).

List major requirements in text, and identify use cases with actor/role and resources. The use cases should bring out high-level requirements and are distinguished from the specification requirements by not refining to lower levels. Policy-related information (e.g., security, persistence) are candidates for inclusion at this level. Numbering the requirements is required for traceability.

Requirements should be specified as described in clause A.1.3. Within a requirements specification, it is suggested that requirements are written in the sequence of clause A.1.3 (either for the entire specification or for each sub-set).

Use of requirements categories is optional, and – when used – a subset of the categories can be applied.

As an example, conceptual requirement number 23 in Recommendation tagged 'SM' would be specified as follows:

Identifier	Definition
REQ-SM-CON-23	A Service Order consists of a name, address, phone number, service description and an optional FAX number for contacts {T1M1.5 Document 246 11/96}

One or more tables can be used with supportive text between tables as necessary.

Annex B

Analysis

(This annex forms an integral part of this Recommendation)

- B.1 Conventions*
 - B.1.1 Mandatory, optional and conditional qualifiers*
- B.2 Analysis template*
 - 1 Concepts and background*
 - 2 Information object classes*
 - 2.1 Imported information entities and local labels*
 - 2.2 Class diagram*
 - 2.2.1 Attributes and relationships*
 - 2.2.2 Inheritance*
 - 2.3 Information object class definitions*
 - 2.3.a InformationObjectClassName*
 - 2.4 Information relationship definitions*
 - 2.4.a InformationRelationshipName (supportQualifier)*
 - 2.5 Information attribute definitions*
 - 2.5.1 Definition and legal values*
 - 2.5.2 Constraints*
 - 2.6 Common notifications*
 - 2.7 System state model*
 - 3 Interface definition*
 - 3.1 Class diagram representing interfaces*
 - 3.2 Generic rules*
 - 3.b Interface InterfaceName (supportQualifier)*
 - 3.b.a Operation OperationName (supportQualifier)*
 - 3.b.b Notification NotificationName (supportQualifier)*
 - 3.c Scenario*
- B.3 IOC properties, inheritance and import*
 - B.3.1 Property*
 - B.3.2 Inheritance*
 - B.3.3 Import*

The following are guidelines for specification of the results of the analysis phase.

The analysis template is based on the 3GPP information service [b-3GPP TS 32.151] and augmented to meet additional requirements on the methodology (e.g., traceability).

For a management interface specification, both clauses 2.2 and 2.3 of "Analysis" template indicated in clause B.2 shall be used. For an information model (e.g., a network resource model), only clause 2.2 shall be used.

The analysis template uses Information Type as one characteristic to describe IOC attributes and operation/notification parameters. The valid Information Type(s) that can be used and their semantics are defined in Annex E.

An example of the use of this template can be found in Appendix II.

The constructs "Analysis|Information Service" and "Design|Solution" sets are used to denote the equivalent, but differently named, specifications developed by ITU-T and 3GPP.

B.1 Conventions

B.1.1 Mandatory, optional and conditional qualifiers

This subclause defines a number of terms used to qualify the relationship between the Analysis|Information Service, the Design|Solution Sets and their impact on the interface implementations. The qualifiers defined in this subclause are used to qualify agent behaviour only. This is considered sufficient for the specification of the management interfaces.

Analysis specification|IS specifications define IOC attributes, interfaces, operations, notifications, operation parameters and notification parameters. They can have the following support/read/write qualifiers: M, O, CM, CO, C.

Definition of qualifier M (Mandatory):

- Used for items that shall be supported.

Definition of qualifier O (Optional):

- Used for items which may or may not be supported.

Definition of qualifier CM (Conditional-Mandatory):

- Used for items that are mandatory under certain conditions, specifically:
 - All items having the support qualifier CM shall have a corresponding constraint defined in the Recommendation|IS specification. If the specified constraint is met, then the items shall be supported.

Definition of qualifier CO (Conditional-Optional):

- Used for items that are optional under certain conditions, specifically:
 - All items having the support qualifier CO shall have a corresponding constraint defined in the Recommendation|IS specification. If the specified constraint is met, then the items may be supported.

Definition of qualifier C (SS-Conditional):

- Used for items that are only applicable for certain but not all Designs|Solutions Sets (SSs).

Design|SS specifications define the SS-equivalents of the IOC attributes, operations, notifications, operation parameters and notification parameters. These SS-equivalents can have the following support/read/write qualifiers: M, O, CM and CO.

The mapping of the qualifiers of Analysis|IS-defined constructs to the qualifiers of the corresponding SS-constructs is defined as follows:

- For qualifier M, O, CM and CO, each IS-defined item (operation and notification, input and output parameter of operations, input parameter of notifications, information relationship and information attribute) shall be mapped to its equivalent(s) in all SSs. Mapped equivalent(s) shall have the same qualifier as the IS-defined qualifier.
- For qualifier C, each IS-defined item shall be mapped to its equivalent(s) in at least one SS. Mapped equivalent(s) can have support qualifier M or O.

Table B.1 defines the semantics of qualifiers of the equivalents, in terms of support from the agent perspective.

Table B.1 – Semantics for qualifiers used in Design|Solution sets

Mapped SS equivalent	Mandatory	Optional	Conditional-Mandatory (CM)	Conditional-Optional (CO)
Mapped notification equivalent	The agent shall generate the notification.	The agent may or may not generate it.	The agent shall generate this notification if the constraint for this item is satisfied.	The agent may choose whether or not to generate it. If the agent chooses to generate it, the constraint for this notification must be satisfied.
Mapped operation equivalent	The agent shall support it.	The agent may or may not support this operation. If the agent does not support this operation, the agent shall reject the operation invocation with a reason indicating that the agent does not support this operation. The rejection, together with a reason, shall be returned to the manager.	The agent shall support this operation if the constraint for this item is satisfied.	The agent may support this operation if the constraint for this item is satisfied.
Input parameter of the mapped operation equivalent	The agent shall accept and behave according to its value.	The agent may or may not support this input parameter. If the agent does not support this input parameter and if it carries meaning (i.e., it does not carry no-information semantics), the agent shall reject the invocation with a reason (that it does not support the parameter). The rejection, together with the reason, shall be returned to the manager.	The agent shall accept and behave according to its value if the constraint for this item is satisfied.	The agent may accept and behave according to its value if the constraint for this item is satisfied.
Input parameter of mapped notification equivalent AND output parameter of mapped operation equivalent	The agent shall supply this parameter.	The agent may supply this parameter.	The agent shall supply this parameter if the constraint for this item is satisfied.	The agent may supply this parameter if the constraint for this item is satisfied.
Mapped IOC attribute equivalent	The agent shall support it.	The agent may support it.	The agent shall support this attribute if the constraint for this item is satisfied.	The agent may support this attribute if the constraint for this item is satisfied.

B.2 Analysis template

1 Concepts and background

This clause should provide an introduction to the management interface specification analysis.

1.a SubSectionTitle

SubSectionTitle is the name of a subclause.

"a" represents a number, starting at 1 and increasing by 1 with each new subclause.

The use of subclauses is optional.

2 Information object classes

This clause shall be used for all specifications (both management interface specifications and information model only specifications).

2.1 Imported information entities and local labels

This clause identifies a list of information entities (e.g., information object class, interface, information relationship, information attribute) that have been defined in other specifications and that are imported in the present document. All imported entities shall be treated as defined locally in the present specification. One usage for import is for inheritance purpose. Each element of this list is a pair (label reference, local label). The label reference contains the name of the specification where it is defined, the type of the information entity and its name. The local label of imported information entities can then be used throughout the specification instead of the label reference.

This information is provided in a table.

Label reference	Local label

Imported elements should be from protocol neutral definitions based on this methodology but may import elements from other specifications, if necessary, in the interest of migration of protocol specific specifications over time.

Guidelines on entity import as well as IOC properties and inheritance can be found in Annex F.

2.2 Class diagram

2.2.1 Attributes and relationships

This first set of diagrams represents all information object classes defined in this IS with all their relationships and all their attributes, including relationships with imported IOCs (if any). These diagrams shall contain information object class cardinalities (for associations as well as containment relationships) and may also contain association names and role names. These shall be UML compliant class diagrams (see also Annex C).

Characteristics (relationships) of imported information object classes need not be repeated in the diagram. Information object classes should be defined using the stereotype <<InformationObjectClass>>.

2.2.2 Inheritance

This second set of diagrams represents the inheritance hierarchy of all information object classes defined in this IS. These diagrams do not need to contain the complete inheritance hierarchy but shall at least contain the parent information object classes of all information object classes defined in the present document. By default, an information object class inherits from the information object class "top". These shall be UML compliant class diagrams.

Characteristics (attributes, relationships) of imported information object classes need not be repeated in the diagram. Information object classes should be defined using the stereotype <<InformationObjectClass>>.

NOTE 1 – Some inheritance relationships presented in clause 2.2.2 can be repeated in clause 2.2.1 to enhance readability.

NOTE 2 – Interface inheritance is shown in clause 3.1 and not in this section.

2.3 Information object class definitions

Each information object class is defined using the following structure.

Inherited items (attributes, etc.) shall not be shown, as they are defined in the parent IOC(s) and thus valid for all subclasses.

2.3.a InformationObjectClassName

InformationObjectClassName is the name of the information object class.

"a" represents a number, starting at 1 and increasing by 1 with each new definition of an IOC.

2.3.a.1 Definition

The <Definition> subclause is written in natural language. The <Definition> subclause refers to the information object class itself. The characteristics related to the relationships that the object class can have with other object classes cannot be found in the definition. The reader has to refer to relationships definition to find such kind of information. Information related to inheritance shall be precised here.

Information on traceability back to one or more requirements supported by this IOC should also be defined here, in the following form:

Reference	Requirements label	Comment

2.3.a.2 Attributes

The <Attributes> subclause presents the list of attributes, which are the manageable properties of the object class. Each element is a tuple (attributeName, supportQualifier, readQualifier, writeQualifier):

- The supportQualifier indicates whether the attribute is Mandatory (M), Optional (O), Conditional-Mandatory (CM), Conditional-Optional (CO), SS-Conditional (C) or Not supported (–). Allowed values are: Mandatory, Optional, Conditional or Not supported ("M", "O", "C", or "–", respectively).
- The readQualifier indicates whether the attribute shall be readable by the manager. The possible values are: Mandatory (M), Optional (O), Conditional-Mandatory (CM), Conditional-Optional (CO), SS-Conditional (C) or Not supported (–). Allowed values are: Mandatory (M), Optional (O) and Not supported (–).
- The writeQualifier indicates whether the attribute shall be writeable by the manager. The semantics for writeQualifier is identical to supportQualifier, for "M", "O", and "–". Allowed values are: Mandatory (M), Optional (O) and Not supported (–).

There is a dependency relationship between the supportQualifier, readQualifier, and writeQualifier. The supportQualifier indicates the requirements for the support of the attribute. For any given attribute, regardless of the value of the supportQualifier, at least one of the readQualifier or writeQualifier must be "M". The implication of the "O" supportQualifier is that the attribute is optional; however, the read and write qualifiers indicate how the optional attribute shall be supported, should the optional attribute be supported.

Private or agent internal attributes are per definition not writable by the IRPManager. Their writeQualifier is hence always "–".

The readQualifier and writeQualifier of a supported attribute, that is public, may not be both "–".

The use of "–" in supportQualifier is reserved for documenting support of attributes defined by an "Archetype" IOC (see clause C.3.5). Attributes with a supportQualifier of "–" are not implemented by the IOC that is realizing a subset of the attributes defined by the "Archetype". The readQualifier and writeQualifier are of no relevance in this case. However, a not supported attribute is neither readable nor writable. For this reason, the readQualifier and writeQualifier shall be "–" for unsupported attributes.

For any IOC that uses one or more attributes from an "Archetype", a separate table shall be used to indicate the supported attributes. This table is absent if no "Archetype" attributes are supported. For example, if a particular IOC has defined attributes (i.e., attributes not defined by an "Archetype") and encapsulates attributes from two "Archetype"s, then the totality of the attributes of the said IOC will be contained in three separate tables.

This information is provided in a table.

Attribute name	Support qualifier	Read qualifier	Write qualifier	Requirement IDs

2.3.a.3 Attribute constraints

The <Attribute constraints> subclause presents constraints between attributes that are always held to be true. Those properties are always held to be true during the lifetime of the attributes and in particular do not need to be repeated in pre- or post-conditions of operations or notifications.

NOTE – This subclause does not need to be present when there are no attribute constraints to define.

2.3.a.4 Relationships

The <Relationship> subclause presents the list of relationships in which this class is involved. Each element is a relationshipName.

The relationships will be listed in a table as follows:

Relationship	Requirement IDs

And each relationship name should be a reference (and preferably also a hyperlink) to the appropriate clause of clause 2 (information object classes).

NOTE – This subclause is optional and may be avoided since all relationships are represented in the class diagram in clause 2.2.1.

2.3.a.5 State diagram

The <State diagram> subclause contains state diagrams. A state diagram of an information object class defines permitted states of this information object class and the transitions between those states. A state is expressed in terms of individual attribute values or a combination of attribute values or involvement in relationships of the information object class being defined. This shall be a UML-compliant state diagram.

NOTE – This subclause does not need to be present when there is no state diagram to define.

2.3.a.6 Notifications

The <Notifications> subclause, for this IOC, presents:

- a) optionally, a reference to the common notifications defined in subclause 2.6 as valid for this IOC, and
- b) optionally, a list of notifications that shall be excluded from the list of common notifications (defined in subclause 2.6) for this IOC (note that inherited notifications from the parent IOC(s) cannot be excluded),

and

- c) optionally, a list of notifications applicable to this IOC, and which may or may not be defined in the common notifications in subclause 2.6.

The notifications identified in this subclause are notifications that can be emitted across the management interface, where the "object class" and "object instance" parameters of the notification header (see Note 2) of these notifications identifies an instance of the IOC defined by the encapsulating subclause (i.e., clause 2.3.a).

The notifications identified in this subclause may originate from implementation object(s) whose identifier is mapped in the implementation, to the object instance identifier used over the management interface. Hence, the presence of notifications in this clause (i.e., clause 2.3.a.6) does not imply nor identify those notifications as being originated from an instance of the IOC defined by the encapsulating subclause (i.e., clause 2.3.a).

The information related to option c) above is provided in a table. An example of such a table is given below:

Name	Qualifier	Requirement IDs	Notes

NOTE 1 – This subclause and table can be absent.

NOTE 2 – The notification header is defined in the notification IRP Information service [b-3GPP TS 32.302].

NOTE 3 – The qualifier of a notification, specified in Notification Table, indicates if such notification can carry the instance DN in the notification. The qualifier of a notification, specified in a management specification, indicates the support level regarding the emission of the subject notification.

A Manager can receive notification-XYZ that carries DN of class-ABC instance if and only if:

- 1) The class-ABC Notification Table defines the notification-XYZ and
- 2) The class-ABC instance implementation supports this notification-XYZ and
- 3) A management interface defines the notification-XYZ and
- 4) The management interface implementation supports this notification-XYZ.

2.4 Information relationship definitions

This clause first lists all the relationships supported by this Recommendation | Specification in the following table. Support qualifier is defined as for attributes in clause B.1.

Relationship	Support Qualifier	Requirement IDs

Each information relationship is defined using the following structure.

Inherited relationships shall not be shown, as they are defined by the parent IOC(s) and thus valid for all subclasses.

2.4.a InformationRelationshipName (supportQualifier)

InformationRelationshipName is the name of the information relationship followed by a qualifier (see clause B.1).

"a" represents a number, starting at 1 and increasing by 1 with each new definition of an information relationship.

2.4.a.1 Definition

The <Definition> subclause is written in natural language.

2.4.a.2 Roles

The <Roles> subclause identifies the roles played in the relationship by object classes. Each element is a pair (roleName, roleDefinition).

This information is provided in a table.

Name	Definition

2.4.a.3 Constraints

The <Constraints> subclause contains the list of properties specifying the semantic invariants that must be preserved on the relationship. Each element is a pair (propertyName, propertyDefinition). Those properties are always held to be true during the lifetime of the relationship and do not need to be repeated in pre- or post-conditions of operations or notifications.

This information is provided in a table.

Name	Definition

2.5 Information attribute definitions

Each information attribute is defined using the following structure.

Inherited attributes shall not be shown, as they are defined in the parent IOC(s) and thus valid for all subclasses.

2.5.1 Definition and legal values

This subclause contains, for each attribute being defined, its Attribute Name, its Definition written in natural language, an Information Type (see Annex E) and an optional list of Legal Values supported by the attribute.

In the case where the Legal Values can be enumerated, each element is a pair (Legal Value Name, Legal Value Semantics), unless a Legal Value Semantics applies to several values in which case the Semantics is provided only once. When the Legal Values cannot be enumerated, the list of Legal Values is defined by a single definition.

This information is provided in a table.

Attribute Name	Definition	Information Type/ Legal Values

2.5.2 Constraints

The <Constraints> subclause indicates whether there are any constraints affecting attributes. Each constraint is defined by a tuple (propertyName, affected attributes, propertyDefinition). PropertyDefinitions are expressed in natural language.

This information is provided in a table.

Name	Affected attribute(s)	Definition

2.6 Common notifications

This <Common Notifications> subclause presents a list of notifications that can be referred to by any IOC defined by this management interface specification. These notifications are only applicable to IOCs referring to this subclause in clause 2.3.a.6.

This information is provided in a table.

Name	Qualifier	Notes

NOTE – This subclause does not need to be present when there are no common notifications.

2.7 System state model

Some configurations of information are special or complex enough to justify the usage of a state diagram to clarify them. A state diagram in this clause defines permitted states of the system and the transitions between those states. A state is expressed in terms of a combination of attribute values constraints or involvement in relationships of one or more information object classes.

3 Interface definition

This clause shall be used for all management interface specifications and optional for information model only specifications.

3.1 Class diagram representing interfaces

Each interface is defined in the diagram. This shall be a UML-compliant class diagram (see also Annex C).

Interfaces are defined using a stereotype <<Interface>>. Each interface contains a set of either operations or notifications which are mandatory or either a single operation or a single notification which is optional. Stereotypes (see Annex C) are used to specify optional or mandatory interfaces. On the class diagram, each operation and notification in an interface shall be qualified as "public" by the addition of a symbol "+" before each operation and notification.

NOTE – Interface inheritance can be shown in this clause.

3.2 Generic rules

The following rules are relevant for all specifications. They shall simply be copied as part of the specification.

Rule 1: Each operation with at least one input parameter supports a pre-condition `valid_input_parameter` which indicates that all input parameters shall be valid with regard to their information type. Additionally, each such operation supports an exception `operation_failed_invalid_input_parameter` which is raised when pre-condition `valid_input_parameter` is false. The exception has the same entry and exit state.

Rule 2: Each operation with at least one optional input parameter supports a set of pre-conditions `supported_optional_input_parameter_xxx` where "xxx" is the name of the optional input parameter and the pre-condition indicates that the operation supports the named optional input parameter. Additionally, each such operation supports an exception `operation_failed_unsupported_optional_input_parameter_xxx` which is raised when (a) the pre-condition `supported_optional_input_parameter_xxx` is false and (b) the named optional input parameter is carrying information. The exception has the same entry and exit state.

Rule 3: Each operation shall support a generic exception `operation_failed_internal_problem` which is raised when an internal problem occurs and that the operation cannot be completed. The exception has the same entry and exit state.

NOTE – Security considerations and resulting generic rules are for further studies.

3.b Interface InterfaceName (supportQualifier)

InterfaceName is the name of the interface followed by a qualifier (see clause B.1).

"b" represents a number, starting at 3 and increasing by 1 with each new definition of an interface.

Each interface is defined by its name and by a sequence of operations or notifications as defined here below.

Each operation is defined using the following structure.

NOTE – Grouping of operations/partitioning of interface contents and naming of interfaces is for further study.

3.b.a Operation OperationName (supportQualifier)

OperationName is the name of the operation followed by a qualifier (see clause B.1).

"a" represents a number, starting at 1 and increasing by 1 with each new definition of an operation.

3.b.a.1 Definition

The <Definition> subclause is written in natural language.

Information on traceability back to one or more requirements supported by this operation should also be defined here, in the following form:

Reference	Requirements label	Comment

3.b.a.2 Input parameters

List of input parameters of the operation. Each element is a tuple (Parameter Name, Support Qualifier, Information Type (see Annex E and Note in clause E.2) and an optional list of Legal Values supported by the parameter, Comment). Legal values for the Support Qualifier are specified in clause B.1.

This information is provided in a table.

Parameter Name	Support Qualifier	Matching Information Type/ Legal Values	Comment

NOTE – Information Type qualifies the parameter of Parameter Name. In the case where the Legal Values can be enumerated, each element is a pair (Legal Value Name, Legal Value Semantics), unless a Legal Value Semantics applies to several values in which case the definition is provided only once. When the Legal Values cannot be enumerated, the list of Legal Values is defined by a single definition.

3.b.a.3 Output parameters

List of output parameters of the operation. Each element is a tuple (Parameter Name, Support Qualifier, Matching Information / Information Type (see Annex E and Note in clause E.2) and an optional list of Legal Values supported by the parameter, Comment). Legal values for the Support Qualifier are specified in clause B.1.

This information is provided in a table.

Parameter Name	Support Qualifier	Matching Information/ Information Type/ Legal Values	Comment

NOTE – Information Type qualifies the parameter of Parameter Name. In the case where the Legal Values can be enumerated, each element is a pair (Legal Value Name, Legal Value Semantics), unless a Legal Value Semantics applies to several values, in which case the definition is provided only once. When the Legal Values cannot be enumerated, the list of Legal Values is defined by a single definition.

This table shall also include a special parameter 'status' to indicate the completion status of the operation (success, partial success, failure reason, etc.).

3.b.a.4 Pre-condition

A pre-condition is a collection of assertions joined by AND, OR, and NOT logical operators. The pre-condition must be held to be true before the operation is invoked.

Each assertion is defined by a pair (propertyName, propertyDefinition). All assertions constituting the pre-condition are provided in a table.

Assertion Name	Definition

3.b.a.5 Post-condition

A post-condition is a collection of assertions joined by AND, OR, and NOT logical operators. The post-condition must be held to be true after the completion of the operation. When nothing is said in a post-condition regarding an information entity, the assumption is that this information entity has not changed compared to what is stated in the pre-condition.

Each assertion is defined by a pair (propertyName, propertyDefinition). All assertions constituting the post-condition are provided in a table.

Assertion Name	Definition

3.b.a.6 Exceptions

List of exceptions that can be raised by the operation. Each element is a tuple (exceptionName, condition, ReturnedInformation, exitState).

3.b.a.6.c exceptionName

ExceptionName is the name of an exception.

"c" represents a number, starting at 1 and increasing by 1 with each new definition of an exception.

This information is provided in a table.

Exception Name	Definition	
	Condition	
	Return info	
	Exit state	
	Condition	
	Return info	
	Exit state	

3.b.a.7 Constraints

The <Constraints> subclause presents constraints for the operation or its parameters.

NOTE – This subclause does not need to be present when there are no constraints to define.

3.b.b Notification NotificationName (supportQualifier)

NotificationName is the name of the notification followed by a qualifier (see clause B.1).

"b" represents a number, starting at 1 and increasing by 1 with each new definition of a notification.

3.b.b.1 Definition

The <Definition> subclause is written in natural language.

Information on traceability back to one or more requirements supported by this notification should also be defined here, in the following form:

Reference	Requirements label	Comment

3.b.b.2 Input parameters

List of input parameters of the notification. Each element is a tuple (Parameter Name, Qualifiers, Matching Information/Information Type (see Annex E and Note in clause E.2) and an optional list of Legal Values supported by the parameter, Comment).

The column "Qualifiers" contains the two qualifiers, Support Qualifier (see clause B.1) and Filtering Qualifier, separated by a comma. The Filtering Qualifier indicates whether the parameter of the notification can be filtered or not. Values are Yes (Y) or No (N).

This information is provided in a table.

Parameter Name	Qualifiers	Matching Information/ Information Type/ Legal Values	Comment

NOTE – Information Type qualifies the parameter of Parameter Name. In the case where the Legal Values can be enumerated, each element is a pair (Legal Value Name, Legal Value Semantics), unless a Legal Value Semantics applies to several values, in which case the definition is provided only once. When the Legal Values cannot be enumerated, the list of Legal Values is defined by a single definition.

3.b.b.3 Triggering event

The triggering event for the notification to be sent is the transition from the information state defined by the "from state" subclause to the information state defined by the "to state" subclause.

3.b.b.3.1 From state

This subclause is a collection of assertions joined by AND, OR, and NOT logical operators.

Each assertion is defined by a pair (propertyName, propertyDefinition). All assertions constituting the state "from state" are provided in a table.

Assertion Name	Definition

3.b.b.3.2 To state

This subclause is a collection of assertions joined by AND, OR and NOT logical operators. When nothing is said in a to-state regarding an information entity, the assumption is that this information entity has not changed compared to what is stated in the from state.

Each assertion is defined by a pair (propertyName, propertyDefinition). All assertions constituting the state "to state" are provided in a table.

Assertion Name	Definition

3.b.b.4 Constraints

The <Constraints> subclause presents constraints for the notification or its parameters.

NOTE – This subclause does not need to be present when there are no constraints to define.

3.c Scenario

This subclause contains one or more sequence diagrams, each describing a possible scenario. These shall be UML-compliant sequence diagrams. This is an optional subclause.

B.3 IOC properties and inheritance

B.3.1 Property

The properties of an IOC (excluding Support IOC) are specified in terms of the following:

- a) An IOC attribute(s) including its semantics and syntax, its legal value ranges and support qualifications. The IOC attributes are not restricted to Configuration Management but also include those related to, for example, 1) Performance Management (i.e., measurement types), 2) Trace Management and 3) Accounting Management.
- b) The non-attribute-specific behaviour associated with an IOC (see Note 1).
NOTE 1 – As an example, the Link between A and B is optional. It is mandatory if the A instance belongs to one ManagedElement instance while the B instance belongs to another ManagedElement instance. This Link behaviour is a non-attribute-specific behaviour. It is expected that this behaviour, like others, will be inherited.
- c) An IOC relationship(s) with another IOC(s).
- d) An IOC notification type(s) and their qualifications.
- e) An IOC's relation with its parents (see Note 2). There are three mutually exclusive cases:
 - 1) The IOC is abstract and no parents have yet been designated.
 - 2) The IOC is abstract and all of the possible parent(s) have been designated and whether subclass IOCs can be designated as a root IOC.
 - 3) The IOC is not abstract and all of the possible parent(s) have been designated and whether the IOC can be designated as a root IOC.

An IOC instance is either a root IOC or it has one and only one parent.

NOTE 2 – The parent and child relation in this clause is the parent name-containing the child relation.

- f) An IOC's relation with its children. There are three mutually exclusive cases:
 - 1) An IOC shall not have any children (name-containment relation) IOCs.
 - 2) An IOC can have children IOC(s). The maximum number of instances per children IOC can be specified. An IOC may designate that vendor-specific objects are not allowed as children IOCs.
 - 3) An IOC can only have the specific children IOC(s) (or their subclasses). The maximum number of instances per children IOC can be specified. An IOC may designate that vendor-specific objects are not allowed as children IOCs.
- g) Whether An IOC can be instantiated or not (i.e., whether an IOC is an abstract IOC).
- h) An attribute for naming purpose.

B.3.2 Inheritance

An IOC (the subclass) inherits from another IOC (the superclass) in that the subclass shall have all the properties of the superclass.

The subclass can change the inherited support-qualification(s) from optional to mandatory but not vice versa. The subclass can change the inherited support-qualification from conditional-optional to conditional-mandatory but not vice versa.

An IOC can be a superclass of many IOC(s). A subclass cannot have more than one superclass.

The subclass can:

- a) Add (compared to those of its superclass) unique attributes including their behaviour, legal value ranges and support-qualifications. Each additional attribute shall have its own unique attribute name (among all added and inherited attributes).

- b) Add non-attribute behaviour on an IOC basis. This behaviour may not contradict inherited superclass behaviour.
- c) Add relationship(s) with IOC(s). Each additional relationship shall have its own unique name (among all added and inherited relations).
- d) Add additional notification types and their qualifications.
- e) Designate all of the possible parent(s) (and their subclasses) if the superclass has Property-e-1 such that an IOC will have Property-e-2 or Property-e-3. Restrict possible parent(s) (and their subclasses) and/or remove the capability of the subclass from being a root IOC, if the superclass has Property-e-2 or Property-e-3.
- f) Add children IOC(s) if the superclass has Property-f-2 such that an IOC will have Property-f-3. Restrict the allowed children IOC(s) (or their subclasses) if the superclass has Property-f-3.
- g) Specify whether an IOC can be instantiated or not (i.e., the IOC is an abstract IOC).
- h) Restrict the legal value range of a superclass attribute that has a legal value range.

B.3.3 Import

To facilitate reuse of IOC definitions among IRP specifications, an import mechanism is used by one IRP specification (called the subject IRP) specification to reuse IOC definition defined in another IRP specification. When the subject IRP specification imports an IOC, it cannot change the imported IOC property. If it requires changes to the imported IOC, it must use inheritance to define its own new class.

Annex C

MISM UML repertoire

(This annex forms an integral part of this Recommendation)

The following are guidelines for specification of the results of the analysis phase as based on 3GPP unified modelling language (UML) repertoire [b-3GPP TS 32.152].

C.1 Introduction

UML provides a rich set of concepts, notations and model elements to model distributed systems. Usage of all UML notations and model elements is not necessary for the purpose of analysis specifications. This annex documents the necessary and sufficient set of UML notations and model elements, including the ones built by the UML extension mechanism <<stereotype>>, for use by development of protocol-neutral specifications. Collectively, this set of notations and model elements is called the UML modelling repertoire.

Recommendations following the methodology shall employ the UML notation and model elements of this repertoire and may also employ other UML notation and model elements considered necessary.

C.2 Basic model elements

C.2.1 General

UML defined a number of basic model elements. This clause lists the selected subset for use in the repertoire. The semantics of the selected ones are defined in [OMG UML].

C.2.2 Attribute

See subclause 3.25 of [OMG UML].

This sample shows some attributes, listed as strings in the attribute compartment of the class AlarmInformation.

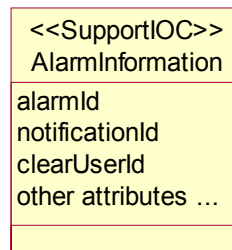

C.2.3 Aggregation

See subclause 3.43.2.5 of [OMG UML].

This sample shows a hollow diamond attached to the end of a path to indicate aggregation. The diamond is attached to the class that is the aggregate.

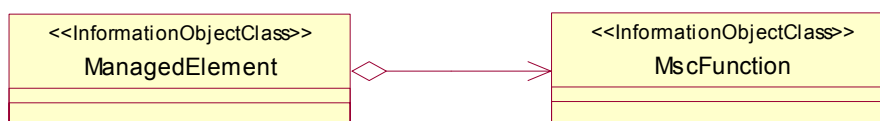

C.2.4 Operation

See subclause 3.26 of [OMG UML].

This sample shows two operations, shown as strings in the operation compartment of class NotificationIRPManagement, that the instance of NotificationIRPManagement may be requested to perform. The operation has a name, e.g., subscribe and a list of arguments (not shown).

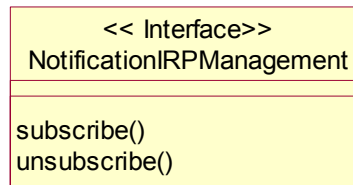

C.2.5 Association and association name

See subclause 3.41 of [OMG UML].

These two samples show a binary association between exactly two model elements. The association can include the possibility of relating a model element to itself. The first sample shows a bi-directional association in that each model element is aware of the other. The second sample shows a unidirectional association (shown with an open arrow at the target model element end) in that only the source model element is aware of the target model element and not vice versa.

Association can be named, such as *abcd* and *label6* in the following samples.

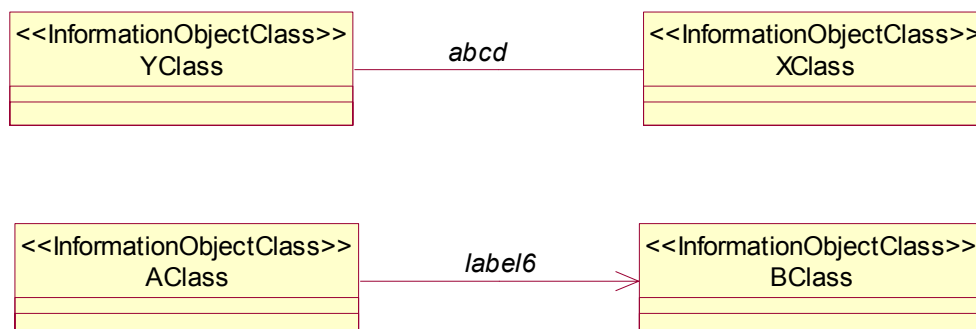

C.2.6 Realization relationship

See subclause 2.5.2.1 of [OMG UML].

This sample shows the realization relationship between a model element AlarmIRP and another model element, AlarmIRPOperations_1. The latter (the target model element) implements the former. The target model element must be an <<Interface>>.



C.2.7 Generalization relationship

See subclause 3.50 of [OMG UML].

This sample shows a generalization relationship between a more general element (the agent) and a more specific element (the Agent_vendor_A) that is fully consistent with the first element and that adds additional information.

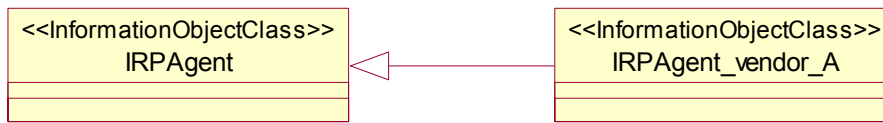

C.2.8 Dependency relationship

See subclause 3.51 of [OMG UML].

This sample shows that BClass instances have a semantic relationship with AClass instances. It indicates a situation in which a change to the target element will require a change to the source element in the dependency.



C.2.9 Note

See subclause 3.11 of [OMG UML].

This sample shows a note, as a rectangle with a "bent corner" in the upper right corner. The note contains arbitrary text. It appears on a particular diagram and may be attached to zero or more modelling elements by dashed lines.

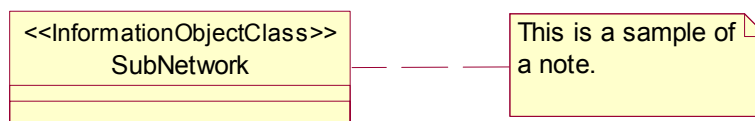

C.2.10 Multiplicity, a.k.a. cardinality

See subclause 3.44 of [OMG UML].

This sample shows a multiplicity attached to the end of an association path. The meaning of this multiplicity is one-to-many. Network instance(s) is associated with zero, one or more SubNetwork instances.

In previous versions of [b-3GPP TS 32.152], the cardinality zero can indicate that the IOC has the so-called "transient state" characteristic. For example, it indicates that the instance is not yet created but it is in the process of being created. In this version of the methodology, the cardinality zero will not be used to indicate this characteristic since such characteristic is considered inherent in all IOCs. All IOCs defined are considered to have such inherent "transient state" characteristics.

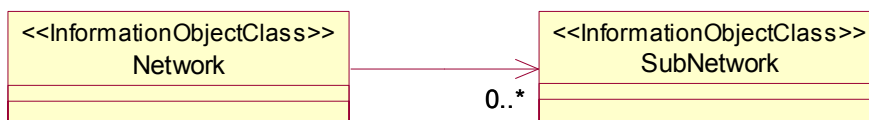

C.2.11 Role name

See subclause 3.43.2.6 of [OMG UML].

This sample shows a Person (say instance John) associated with a Company (say whose DN is "Company=XYZ"). We navigate the association by using the opposite association-end such that John's Person.theCompany would hold the DN, i.e., "Company=XYZ". Use noun for the rolename.

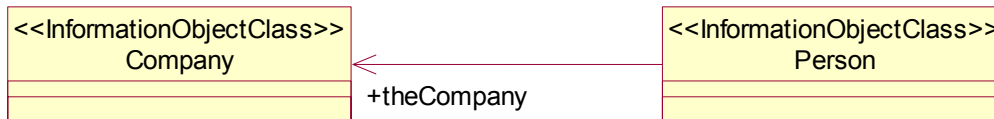

C.2.12 Xor constraint

See subclauses 2.5.2.3 and 3.42.5.1 of [OMG UML].

This sample shows an Account (e.g., account 0960) that is associated with a Person (e.g., John Smith) or a Corporation (e.g., ABC Inc).

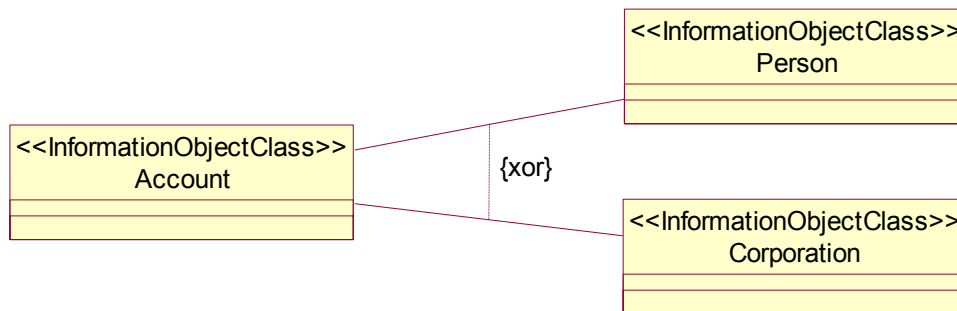

C.3 Stereotypes

C.3.1 General

This subclause lists all allowable stereotypes to be used in management interface specifications. One stereotype <<Interface>> is defined in [OMG UML]. This Recommendation lists it out for ease of reference and completeness. Other stereotypes are defined in this Recommendation.

Table C.3-1 – Entity stereotypes

Stereotype	Base class	Affected metamodel elements
Interface	Class	
ProxyClass	Class	
Notification	Class	
Archetype	Classifier (subclause 2.5.2.10 of [OMG UML])	
InformationObjectClass	Classifier	
SupportIOC	Classifier	
use	Association	
may use	Association	
may realize	Association	
names	Composition	

C.3.2 <<Interface>>

Subclause 2.5.2.25 of [OMG UML]:

"An interface is a named set of operations that characterize the behaviour of an element. In the metamodel, an Interface contains a set of Operations that together define a service offered by a Classifier realizing the Interface. A Classifier may offer several services, which means that it may realize several Interfaces, and several Classifiers may realize the same Interface.

Interfaces [may or] may not have Attributes, Associations, or Methods. An Interface may participate in an Association provided the Interface cannot see the Association; that is, a Classifier (other than an Interface) may have an Association to an Interface that is navigable from the Classifier but not from the Interface."

From subclause 2.5.4.6 of [OMG UML]:

"The purpose of an interface is to collect a set of operations that constitute a coherent service offered by classifiers. Interfaces provide a way to partition and characterize groups of operations. An interface is only a collection of operations with a name. It cannot be directly instantiated."

From subclause 2.5.4.6 of [OMG UML]:

"Several classifiers may realize the same interface. All of them must contain at least the operations matching those contained in the interface. The specification of an operation contains the signature of the operation (i.e., its name, the types of the parameters and the return type). An interface does not imply any internal structure of the realizing classifier. For example, it does not include which algorithm to use for realizing an operation. An operation may, however, include a specification of the effects [e.g., with pre and post-conditions] of its invocation."

C.3.2.1 Sample

This sample shows an AlarmIRPOperations_1 <<Interface>> that has two operations. The input and output parameters of the operations are hidden (i.e., not shown). The AlarmIRP has a unidirectional mandatory realization relationship with the <<Interface>>.

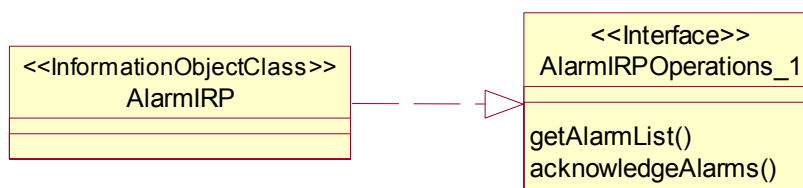

<<Interface>> Notation

C.3.3 <<ProxyClass>>

C.3.3.1 General

This represents a number of <<InformationObjectClass>>. It encapsulates attributes, links, methods (or operations), and interactions that are present in the represented <<InformationObjectClass>>.

The semantics of a <<ProxyClass>> is that all behaviour of the <<ProxyClass>> are present in the represented <<InformationObjectClass>>. Since this class is simply a representation of other classes, this class cannot define its own behaviour other than those already defined by the represented <<InformationObjectClass>>.

A particular <<InformationObjectClass>> can be represented by zero, one or more <<ProxyClass>> or <<Archetype>>. For example, the ManagedElement <<InformationObjectClass>> can have MonitoredEntity <<ProxyClass>> and ManagedEntity <<ProxyClass>>.

The attributes of the <<ProxyClass>> are accessible by the source entity that has an association with the <<ProxyClass>>.

C.3.3.2 Sample

This shows a <<ProxyClass>> named MonitoredEntity. It represents all NRM <<InformationObjectClass>> (e.g., GgsnFunction <<InformationObjectClass>>) whose instances are being monitored for alarm conditions.

Note that <<MonitoredEntity>> does not define any attributes. The attributes are already defined by all <<InformationObjectClass>> represented by the <<MonitoredEntity>>.

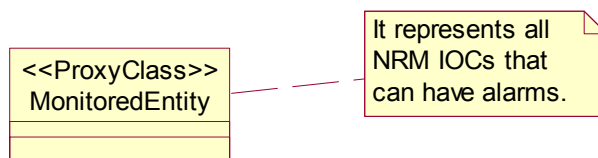

<<ProxyClass>> Notation

See Appendix V for more samples that use <<ProxyClass>>.

C.3.4 <<Archetype>>

C.3.4.1 General

This represents a number of common class properties (e.g., attributes, links, operations, and interactions that are typical of the represented <<InformationObjectClass>>.

The semantics of an <<Archetype>> is that all attributes, links operations and interactions encapsulated by the <<Archetype>> may or may not be present in the represented <<InformationObjectClass>>. The <<Archetype>> represents a placeholder class that is most useful in technology neutral analysis models that will require further specification and/or mapping within a more complete construction model.

C.3.4.2 Sample

This shows an <<Archetype>> named StateManagement. It also shows an <<InformationObjectClass>> Agent that depends on this StateManagement. Note that the StateManagement has defined a number of attributes (not shown in the UML diagram). The classes that depend on this StateManagement may or may not use all of the StateManagement attributes. In other words, at least one of the attributes of StateManagement is present in the Agent. The precise set of StateManagement attributes used by the Agent is specified in the Agent specification.



<<Archetype>> Notation

C.3.5 <<InformationObjectClass>>

C.3.5.1 General

This represents an IOC. Each <<InformationObjectClass>> represents a set of instances with similar structure, behaviour and relationships.

This <<InformationObjectClass>> and other information classes such as <<Interface>> are mapped into technology-specific model elements such as GDMO Managed Object Class for CMIP technology. The mapping of the protocol-neutral modelling constructs to technology-specific modelling constructs are captured in the corresponding protocol-specific specifications.

The name of an <<InformationObjectClass>> has scope within the Recommendation in which it is specified and the name must be unique among all <<InformationObjectClass>> names within that Recommendation. The Recommendation name is considered in the similar way as the UML Package-name.

The <<InformationObjectClass>> is identical to UML class except that it does not include/define methods or operations.

Subclause 3.22.1 of [OMG UML]: "A class represents a concept within the system being modelled. Classes have data structure and behaviour and relationships to other elements."

C.3.5.2 Sample

This sample shows an AlarmList <<InformationObjectClass>>.

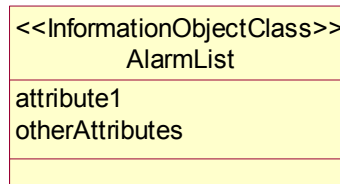

<<InformationObjectClass>> Notation

C.3.6 <<use>> and <<may use>>

The <<use>> and <<may use>> are unidirectional associations. The target must be an <<Interface>> or <<Notification>>.

In the case where the target is <<Interface>>, the <<use>> states that the source class must have the capability to use the target <<Interface>> in that it can invoke the operations defined by the <<Interface>>. Support of the capability by the source entity is mandatory. The <<may use>> states that the source class may have the capability to use the target <<Interface>> in that it may invoke the operations defined by the <<Interface>>. Support of the capability by the source entity is optional.

In the case the target is <<Notification>>, the <<use>> states that the source class must be the originator of the notifications defined by the target <<Notification>>. Support of the capability by the source entity is mandatory. The <<may use>> states that the source class may be the originator of the notifications defined by the target <<Notification>>. Support of the capability by the source entity is optional.

C.3.6.1 Sample for target <<Interface>>

This shows that the IRPManager shall use the operations defined by AlarmIRPOperations_1 and may use the operations defined by AlarmIRPOperations_2.

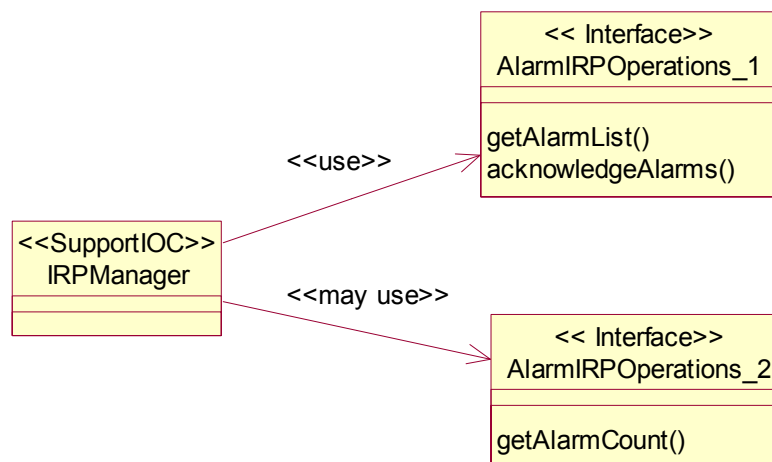

<<use>> and <<may use>> Notation for target <<Interface>>

C.3.6.2 Sample for target <<Notification>>

This shows that the PMIRP shall have the capability to emit or originate notifications defined by PMIRPNotifications_1 and may have the capability to emit or originate notifications defined by PMIRPNotifications_2.

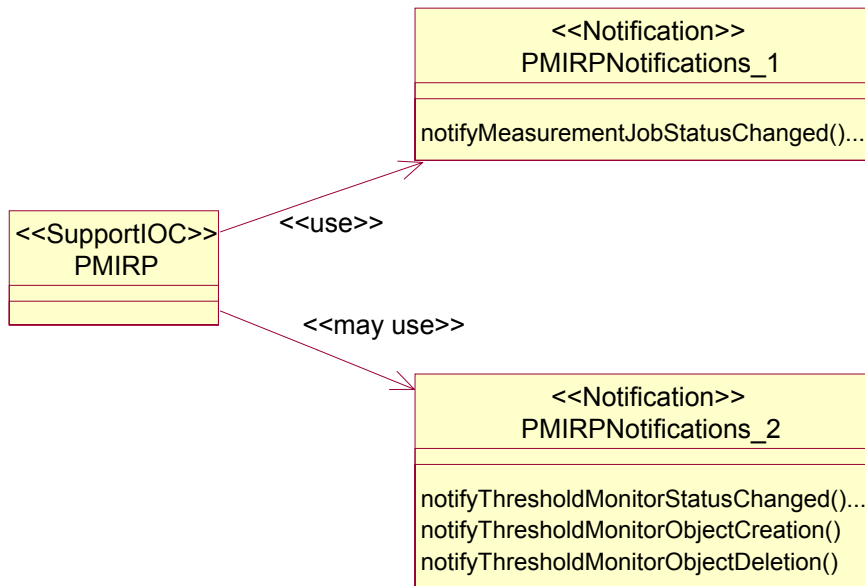

<<use>> and <<may use>> Notation for target <<Notification>>

C.3.7 <<may realize>>

The <<may realize>> is a unidirectional association. The target must be an <<Interface>>. The <<may realize>> shows that the source entity may realize the operations defined by the target <<Interface>>.

Note that the UML basic element has defined the realize association (and therefore, there is no need to define a stereotype of such association). The realize association shows that the source entity must realize (or implement) the operations defined by the target <<Interface>>.

C.3.7.1 Sample

This shows that the AlarmIRP may realize the operation of AlarmIRPOperations_2.

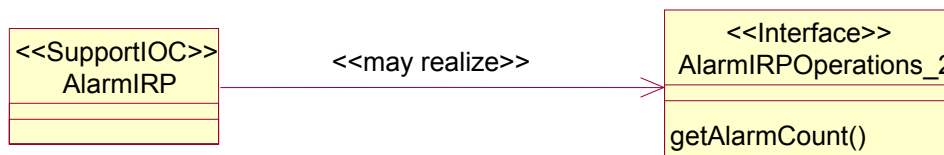

<<may realize>> Notations

C.3.8 <<names>>

It specifies a unidirectional composition. The target instance is uniquely identifiable, within the namespace of the source entity, among all other targeted instances of the same target classifier and among other targeted instances of other classifiers that have the same <<names>> composition with the source.

The source classifier and target classifier shall both have a naming attribute.

Composition used as the act of name containment provides a semantic of a whole-part relationship between the domain and the named elements that are contained, even if only by name. From the management perspective, access to the part is through the whole. Multiplicity shall be indicated at both ends of the relationship.

A target instance cannot have multiple <<names>> with multiple sources, i.e., a target instance can not participate in or belong to multiple namespaces.

C.3.8.1 Sample

This shows that all instances of MscFunction are uniquely identifiable within a ManagedElement instance's namespace.

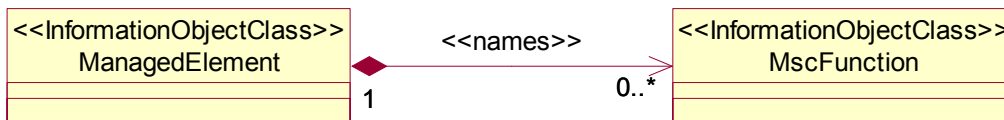

<<names>> Notation

C.3.9 <<opt>>

The <<opt>> (alternatively <<optional>>) enables the indication of optionality of attributes, parameters and operations (respectively) within the UML diagrams.

In the absence of the stereotype, the attribute, parameter, or operation in question is mandatory.

C.3.9.1 Sample

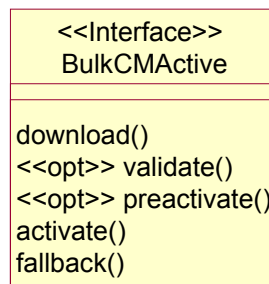

<<opt>> Notation for operations

C.3.10 <<Notification>>

C.3.10.1 General

<<Notification>> is a named set of notifications.

C.3.10.2 Sample

This sample shows a <<Notification>> named "PMIRPNotifications_1" and another <<Notification>> named "PMIRPNotifications_2". Both of them have notification(s). An example of a notification can be notifyMeasurementJobStatusChanged().

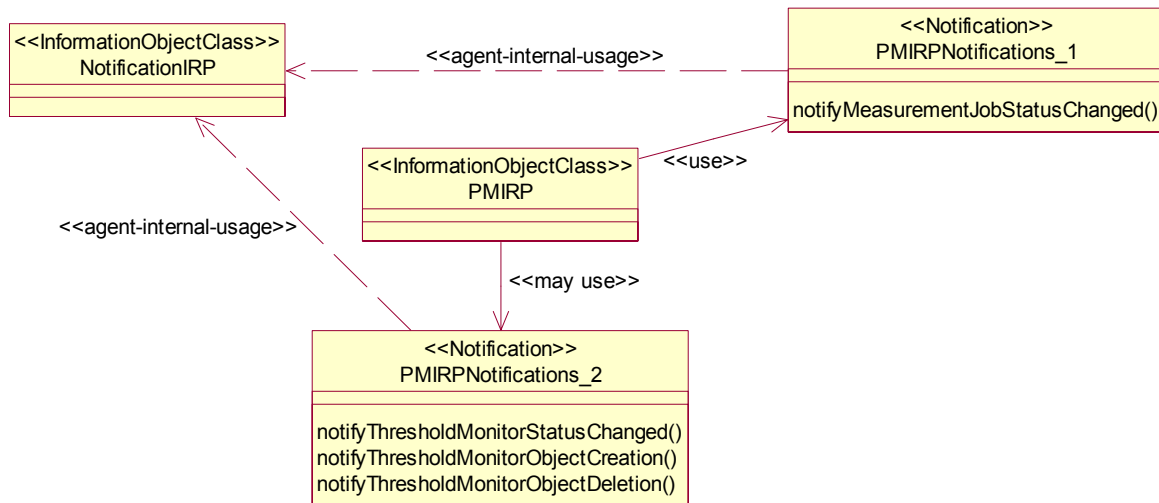

<<Notification>> Notation

C.3.11 <<agent-internal-usage>>

This is a unidirectional association. The source passes network management information to target. The source and target are entities or processes running in different IRP instances such as AlarmIRP, PMIRP. The instances may be name-contained by the same IRPAgent or different IRPAgent instances. The precise network management information passed and the information transfer mechanism are not standardized and are vendor-specific.

C.3.11.1 Sample

This shows that NLIRP (NotificationLog IRP) can pass some network management information to FTIRP (FileTransferIRP).

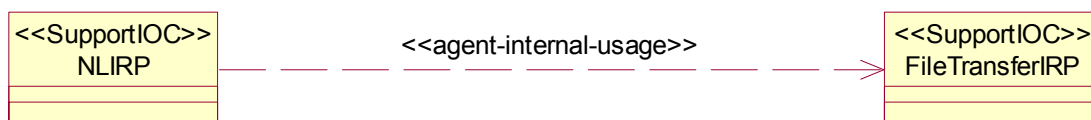

<<agent-internal-usage>> Notation

C.3.12 <<SupportIOC>>

It is the descriptor for a set of management capabilities.

The <<SupportIOC>> is identical to UML *class* except that it does not include/define methods or operations.

Subclause 3.22.1 of [OMG UML]: "A class represents a concept within the system being modelled. Classes have data structure and behaviour and relationships to other elements."

C.3.12.1 Sample

This sample shows an AlarmList <<SupportIOC>>.



<<SupportIOC>> Notation

C.4 Association classes

Subclause 3.46 of [OMG UML] defines an association class as:

"An association class is an association that also has class properties (or a class that has association properties). Even though it is drawn as an association and a class, it is really just a single model element."

Association classes are appropriate for use when an "InformationObjectClass" needs to maintain associations to several other "InformationObjectClass"es and there are relationships between the members of the associations within the scope of the "containing" "InformationObjectClass". For example, a namespace maintains a set of bindings, a binding ties a name to an object. A Binding "IOC" can be modelled as an Association class that provides the binding semantics to the relationship between a name and some other "InformationObjectClass". This is depicted in the following figure (exemplary only, not taken from another Recommendation).

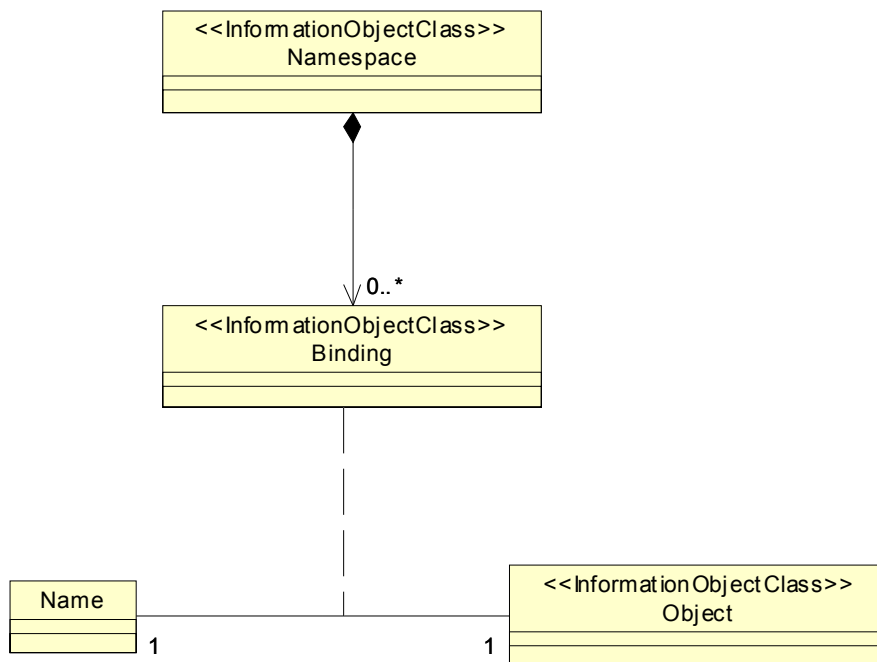

Example of an Association class

C.5 Abstract class

C.5.1 General

It specifies an <<InformationObjectClass>> as a base class to be inherited by subclasses. An abstract class cannot be instantiated.

Abstract class notation is the use of italics in the class name of the corresponding <<InformationObjectClass>> in the diagram.

C.5.2 Sample

This shows that ManagedGenericIRP is an abstract <<InformationObjectClass>>.

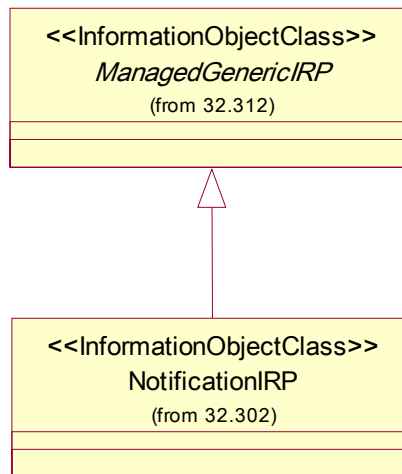

Abstract class notation

C.6 Application of <<InformationObjectClass>> and <SupportIOC>>

The <<InformationObjectClass>> and <<SupportIOC>> are stereotypes. These two stereotypes serve a similar purpose in that each is a named set of management properties. However, their applications, in the context of supporting management over a management interface, can be different. This clause highlights their similarities and differences of such application.

	<<InformationObjectClass>>	<<SupportIOC>>
Can it be an abstract class?	Yes	Yes
Can it be a concrete class?	Yes	Yes
Can it inherit from <<InformationObjectClass>>?	Yes	No
Can it inherit from <<SupportIOC>>?	No	Yes
Can it be name-contained by <<InformationObjectClass>>?	Yes	Yes
Can it be name-contained by <<SupportIOC>>?	No	Yes
Can an instance have a DN?	<<InformationObjectClass>> must be a class of a naming-tree, meaning all its instances must have a DN.	<<SupportIOC>> may be used by specification author for a class within a naming-tree. If so, it means that all its instances will have a DN.
Can a Manager receive information via notifications whose objectClass and objectInstance parameters carry the instance DN?	Yes. The types of notification emitted are shown by the Notification Table associated with the class definition.	Yes if <<SupportIOC>> is a class of a naming-tree. The types of notification emitted are shown by the Notification Table associated with the class definition. No if <<SupportIOC>> is not a class of a naming-tree.

Annex D

Design

(This annex forms an integral part of this Recommendation)

This annex provides guidelines for specification of protocol specific designs.
For further study.

Annex E

Information type definitions – type repertoire

(This annex forms an integral part of this Recommendation)

This annex defines a repertoire of types that shall be used to specify type information in the conceptual model (analysis model/information service).

The repertoire is defined as a subset of types defined by ASN.1 [ITU-T X.680] combined with types derived from the types defined by ASN.1 (clause E.4).

The keywords to be used for each type are summarized in Table E.1.

E.1 Basic types

Basic types are types that can be used directly to define attributes and parameters. Basic types can also be used to construct complex types. Basic types include the following ASN.1 types:

- E.1.1 **integer type** clause 19 of [ITU-T X.680]
- E.1.2 **real type** clause 21 of [ITU-T X.680]
- E.1.3 **boolean type** clause 18 of [ITU-T X.680]
- E.1.4 **bitstring type** clause 22 of [ITU-T X.680]
- E.1.5 **null type** clause 24 of [ITU-T X.680]
- E.1.6 **generalized time type** clause 38 of [ITU-T X.680]

E.2 Enumerated type

Enumerated type clause 20 of [ITU-T X.680] represents enumerated values. All values that may be used by a specific attribute or parameter shall be listed in the legal value columns. Only the listed names style is applicable for the conceptual model, i.e., the identification of concrete values (numbers or strings) are left for the concrete design models.

NOTE – If the number of these values is more than 50, it is recommended to define them in an appendix or an independent document.

E.3 Complex types

Complex types can be defined using the following concepts:

- E.3.1 **sequence types** clause 25 of [ITU-T X.680]
- E.3.2 **choice types** clause 29 of [ITU-T X.680]
- E.3.3 **set types** clause 27 of [ITU-T X.680]

In addition, lists and sets of complex types are supported using:

- E.3.4 **sequence-of types** clause 26 of [ITU-T X.680]
- E.3.5 **set-of types** clause 28 of [ITU-T X.680]

E.4 Useful types

E.4.1 String type

String represents a string of characters, the character set is not restricted, i.e.:

String ::= UnrestrictedCharacterStringType clause 44 of [ITU-T X.680]

E.4.2 Name type

Name represents an exclusive name of an object instance in name space. It might include object containment tree hierarchy information, but it is implementation dependent and is out of the scope of this Recommendation. Formally, the name type is defined as:

Name ::= TYPE-IDENTIFIER Annex A of [ITU-T X.681]

E.5 Keywords

Table E.1 defines the list of keywords to be used in the analysis template (see Annex B) for definition of information type, e.g.:

Parameter Name	Support Qualifier	Information Type/Legal Values	Comment
...			
eventIdList	M	SET OF INTEGER/-	The list of alarms to be acknowledged.

Table E.1 – Keywords

Type	Keyword
integer type	INTEGER
real type	REAL
boolean type	BOOLEAN
bitstring type	BIT STRING
null type	NULL
generalized time type	GeneralizedTime
enumerated type	ENUMERATED
sequence type	SEQUENCE
choice type	CHOICE
set type	SET
sequence-of type	SEQUENCE OF
set-of type	SET OF
string type	String
name type	Name

Annex F

Guidelines on IOC properties, inheritance and entity import

(This annex forms an integral part of this Recommendation)

The following guidelines are based on [b-3GPP TS 32.150].

F.1 IOC property

The properties of an IOC (including Support IOC) are specified in terms of the following:

a) An IOC attribute(s) including its semantics and syntax, its legal value ranges and support qualifications. The IOC attributes are not restricted to Configuration Management but also include those related to, for example, 1) Performance Management (i.e., measurement types), 2) Trace Management and 3) Accounting Management.

b) The non-attribute-specific behaviour associated with an IOC.

NOTE 1 – As an example, the Link between MscServerFunction and CsMgwFunction is optional. It is mandatory if the MscServerFunction instance belongs to one ManagedElement instance while the CsMgwFunction instance belongs to another ManagedElement instance. This Link behaviour is a non-attribute-specific behaviour. It is expected that this behaviour, like others, will be inherited.

c) An IOC relationship(s) with another IOC(s).

d) An IOC notification type(s) and their qualifications.

e) An IOC's relation with its parents (see Note 2). There are three mutually exclusive cases:

- 1) The IOC can have any parent. In UML diagram, the class has a parent Any.
- 2) The IOC is abstract and all of the possible parent(s) have been designated and whether subclass IOCs can be designated as a root IOC. In UML diagram, the class has zero or more possible parents of specific classes (except Any).
- 3) The IOC is concrete and all of the possible parent(s) have been designated and whether the IOC can be designated as a root IOC. In UML diagram, the class has one or more possible parents of specific classes (except Any).

An IOC instance is either a root IOC or it has one and only one parent. Only 3GPP SA5 may designate an IOC class as a potential root IOC. Currently, only SubNetwork, ManagedElement or MeContext IOCs can be root IOCs.

NOTE 2 – The parent and child relation in this clause is the parent name-containing the child relation.

f) An IOC's relation with its children. There are three mutually exclusive cases:

- 1) An IOC shall not have any children (name-containment relation) IOCs. In UML diagram, the class has no child.
- 2) An IOC can have children IOC(s). The maximum number of instances per children IOC can be specified. An IOC may designate that vendor-specific objects are not allowed as children IOCs. In UML diagram, the class has a child Any.
- 3) An IOC can only have the specific children IOC(s) (or their subclasses). The maximum number of instances per children IOC can be specified. An IOC may designate that vendor-specific objects are not allowed as children IOCs. In UML diagram, the class has one or more children of specific classes (except Any).

g) Whether An IOC can be instantiated or not (i.e., whether an IOC is an abstract IOC).

h) An attribute for naming purpose.

F.2 Inheritance

An IOC (the subclass) inherits from another IOC (the superclass) in that the subclass shall have all the properties of the superclass.

The subclass can change the inherited support-qualification(s) from optional to mandatory but not vice versa. The subclass can change the inherited support-qualification from conditional-optional to conditional-mandatory but not vice versa.

An IOC can be a superclass of many IOC(s). A subclass cannot have more than one superclass.

The subclass can:

- a) Add (compared to those of its superclass) unique attributes including their behaviour, legal value ranges and support-qualifications. Each additional attribute shall have its own unique attribute name (among all added and inherited attributes).
- b) Add non-attribute behaviour on an IOC basis. This behaviour may not contradict inherited superclass behaviour.
- c) Add relationship(s) with IOC(s). Each additional relationship shall have its own unique name (among all added and inherited relations).
- d) Add additional notification types and their qualifications.
- e) Designate all of the possible parent(s) (and their subclasses) if the superclass has Property-e-1 such that an IOC will have Property-e-2 or Property-e-3. Restrict possible parent(s) (and their subclasses) and/or remove the capability of the subclass from being a root IOC, if the superclass has Property-e-2 or Property-e-3.
- f) Add children IOC(s) if the superclass has Property-f-2 such that an IOC will have Property-f-3. Restrict the allowed children IOC(s) (or their subclasses) if the superclass has Property-f-3.
- g) Specify whether an IOC can be instantiated or not (i.e., the IOC is an abstract IOC).
- h) Restrict the legal value range of a superclass attribute that has a legal value range.

F.3 Entity (interface, IOC and attribute) import

Management interface specifications define entities (e.g., IOCs, interfaces and attribute). To facilitate the reuse of entity definitions among interface specifications, an import mechanism is used. When a management interface specification (the subject specification) imports an entity defined in another management interface specification, the subject specification is considered to have defined the imported entity in its specification. Furthermore, the subject specification cannot change the properties of this imported entity. If it requires an entity that is not identical but similar to the imported entity, it should define a new entity that inherits the imported entity and introduce changes in the new entity definition.

Appendix I

Requirements example

(This appendix does not form an integral part of this Recommendation)

NOTE – The following example is based on alarm management, but is used for illustrative purposes only and not intended to be a complete or correct set of requirements for alarm management.

1 Concepts and background

Any evaluation of the NEs' and the overall network health status requires the detection of faults in the network and, consequently, the notification of alarms to the OS (EM and/or NM).

2 Business level requirements

2.1 Requirements

Faults that may occur in the network can be grouped into one of the following categories:

- Hardware failures, i.e., the malfunction of some physical resource within a NE.
- Software problems, e.g., software bugs, database inconsistencies.

2.1.1 Fault detection

REQ-FM-FUN-01 The majority of the faults should have well-defined conditions for the declaration of their presence or absence, i.e., fault occurrence and fault clearing conditions. Any such incident shall be referred to in this appendix as an ADAC fault. The network entities should be able to recognize when a previously detected ADAC fault is no longer present, i.e., the clearing of the fault, using similar techniques as they use to detect the occurrence of the fault.

2.1.2 Clearing of alarms

The alarms originated in consequence of faults need to be cleared. To clear an alarm, it is generally necessary to repair the corresponding fault.

...

REQ-FM-FUN-02 Each time an alarm is cleared, the Agent shall generate an appropriate clear alarm event. A clear alarm is defined as an alarm.

2.1.3 Alarm forwarding and filtering

REQ-FM-FUN-03 For each detected fault, appropriate alarms (notifications of the fault) shall be generated by the faulty network entity.

...

2.2 Actor roles

Managed system The entity performing an agent role.

Managing system The entity performing the manager role.

2.3 Telecommunication resources

The managed network equipment is viewed as relevant telecommunication resources in this Recommendation.

2.4 High-level use case diagrams

2.4.1 Report alarm

The first overview use case diagram in Figure I.1 shows the overall interaction of the alarm interface.

The first overview use case diagram shows the interactions involved in reporting a detected failure.

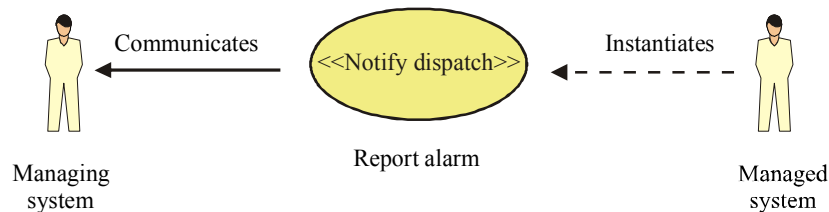

M.3020(10)_F.I.1

Figure I.1 – Report alarm

3 Specification level requirements

3.1 Requirements

There are no specification level requirements.

3.2 Actor roles

See clause 2.2 of this template.

3.3 Telecommunication resources

See clause 2.3 of this template.

3.4 Use cases

3.4.1 Fault notification

Use case stage	Evolution/Specification	<<Uses>> Related use
Goal (*)	Upon detection of a failure condition, the managed system sends an alarm report notification, through interface Q, of the relevant type to the managing system.	
Actors and Roles (*)	The managing system is a consumer of notifications from the managed system.	
Telecom resources	Any managed entity.	
Assumptions	A fault condition is detected.	
Pre-conditions	There is an open communication channel between the managing system and the managed system.	
Begins when	A fault condition is detected.	
Step 1 (*)	Upon detection of a failure condition, an appropriate alarm report or security alarm report is created.	
Ends when	Alarm report or security alarm report is emitted by the agent.	
Exceptions	Communication or process failure could result in a failure to deliver the alarm report to the managing system. The alarm synchronization use case covers this situation.	
Post-conditions	The managing system is informed of the fault condition in the managed system.	
Traceability (*)	REQ-FM-FUN-01, REQ-FM-FUN-02, etc.	

3.4.2 Alarm clear

...

3.4.3 Acknowledge alarm

...

Appendix II

Analysis example

(This appendix does not form an integral part of this Recommendation)

NOTE – The following example is based on alarm management, but is used for illustrative purposes only and not intended to be a complete or correct set of requirements for alarm management.

1 Concepts and background

Any evaluation of the NEs' and the overall network health status requires the detection of faults in the network and, consequently, the notification of alarms to the OS (EM and/or NM).

...

2 Information object classes

2.1 Information entities imported and local label

Label reference	Local label
3GPP TS 32.302, information object class, NotificationIRP	NotificationIRP
3GPP TS 32.302, interface, notificationIRPNotification	NotificationIRPNotification
3GPP TS 32.622, information object class, IRPAgent	IRPAgent
3GPP TS 32.312, information object class, ManagedGenericIRP	ManagedGenericIRP

2.2 Class diagram

This clause introduces the set of information object classes (IOCs) that encapsulate information within the agent. The intent is to identify the information required for the AlarmAgent implementation of its operations and notification emission. This clause provides the overview of all support object classes in UML. Subsequent clauses provide more detailed specification of various aspects of these support object classes.

2.2.1 Attributes and relationships

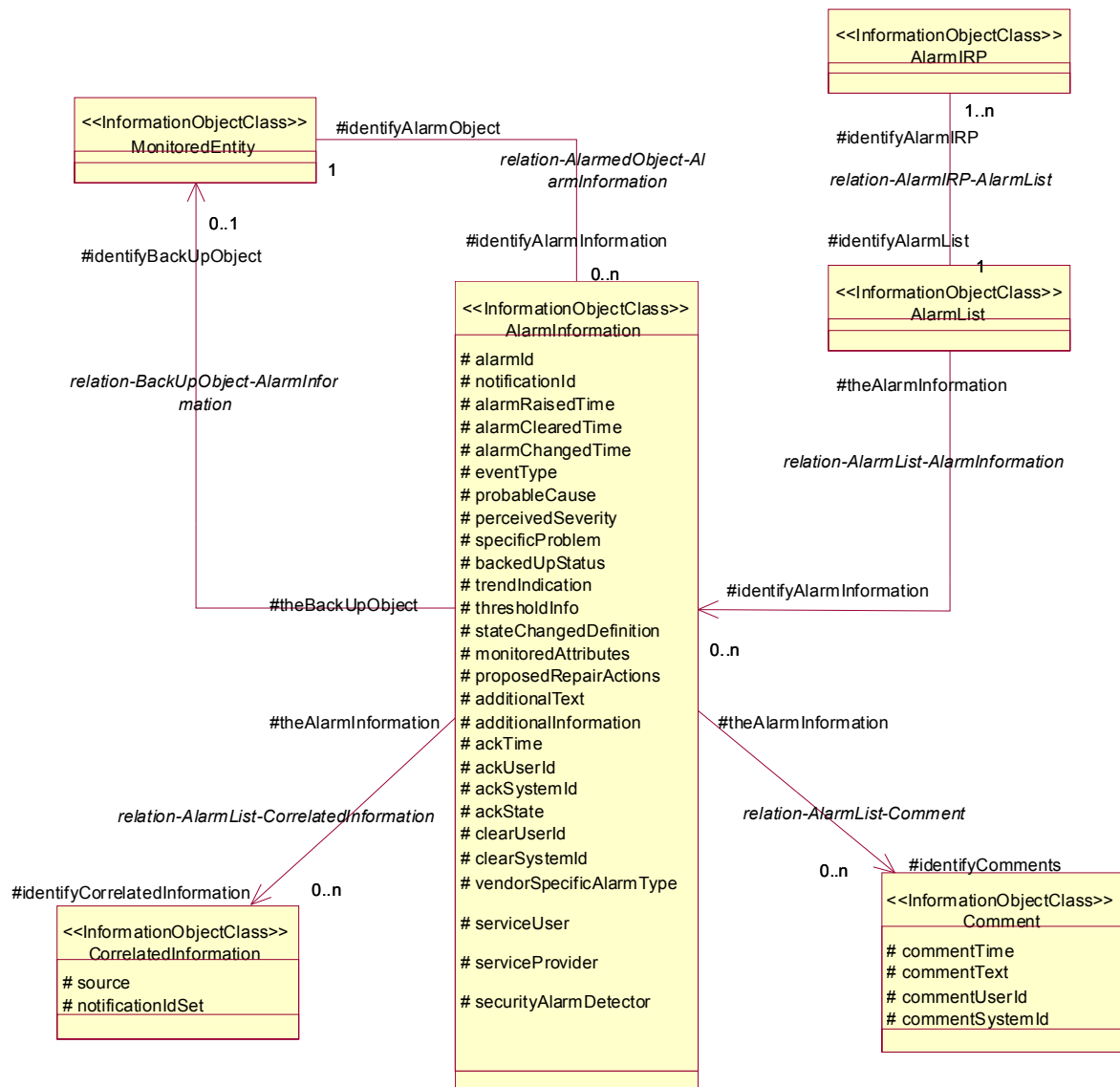

Figure II.1 – Alarm management information object classes

2.2.2 Inheritance

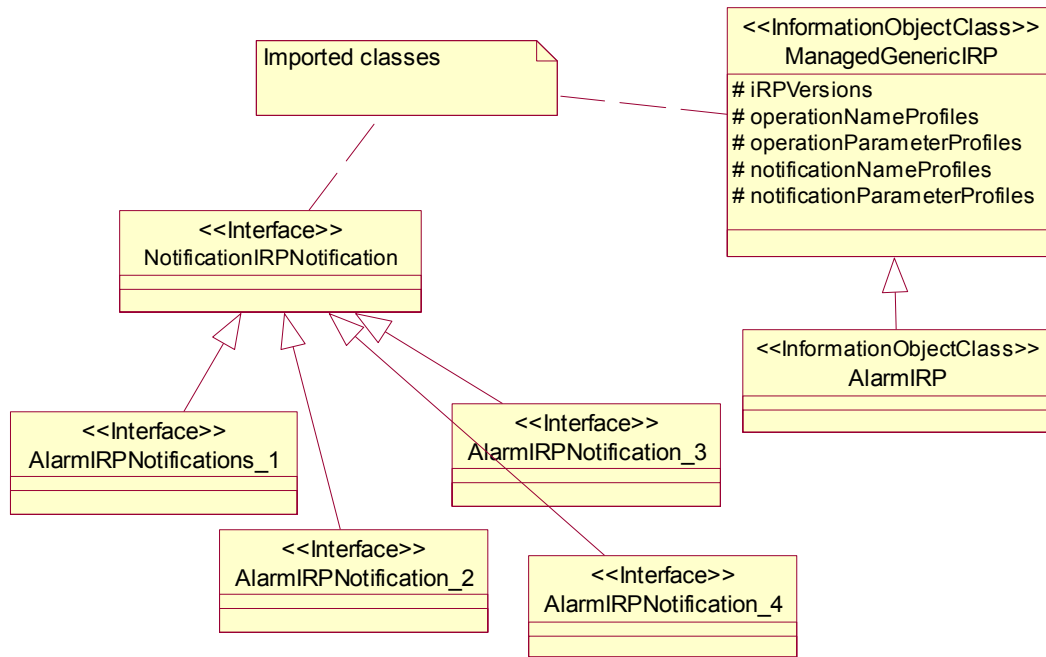

Figure II.2 – Alarm management IOC inheritance

2.3 Information object class definitions

Class name	Qualifier	Requirement IDs
AlarmInformation	M	REQ-FM-FUN-01, REQ-FM-FUN-02, etc.
AlarmList	M	REQ-FM-FUN-n
...		

2.3.1 AlarmInformation

2.3.1.1 Definition

AlarmInformation contains information about an alarm condition of an alarmed MonitoredEntity.

....

2.3.1.2 Attributes

Attribute name	Support qualifier	Read qualifier	Write qualifier	Requirement IDs
alarmed	M	M	M	
probableCause	C	M	C	
structuredProbableCause	C	M	C	
perceivedSeverity	M	M	M	
specificProblem	O	O	O	
...				
...				

2.3.1.3 State diagram

Alarms have states.

...

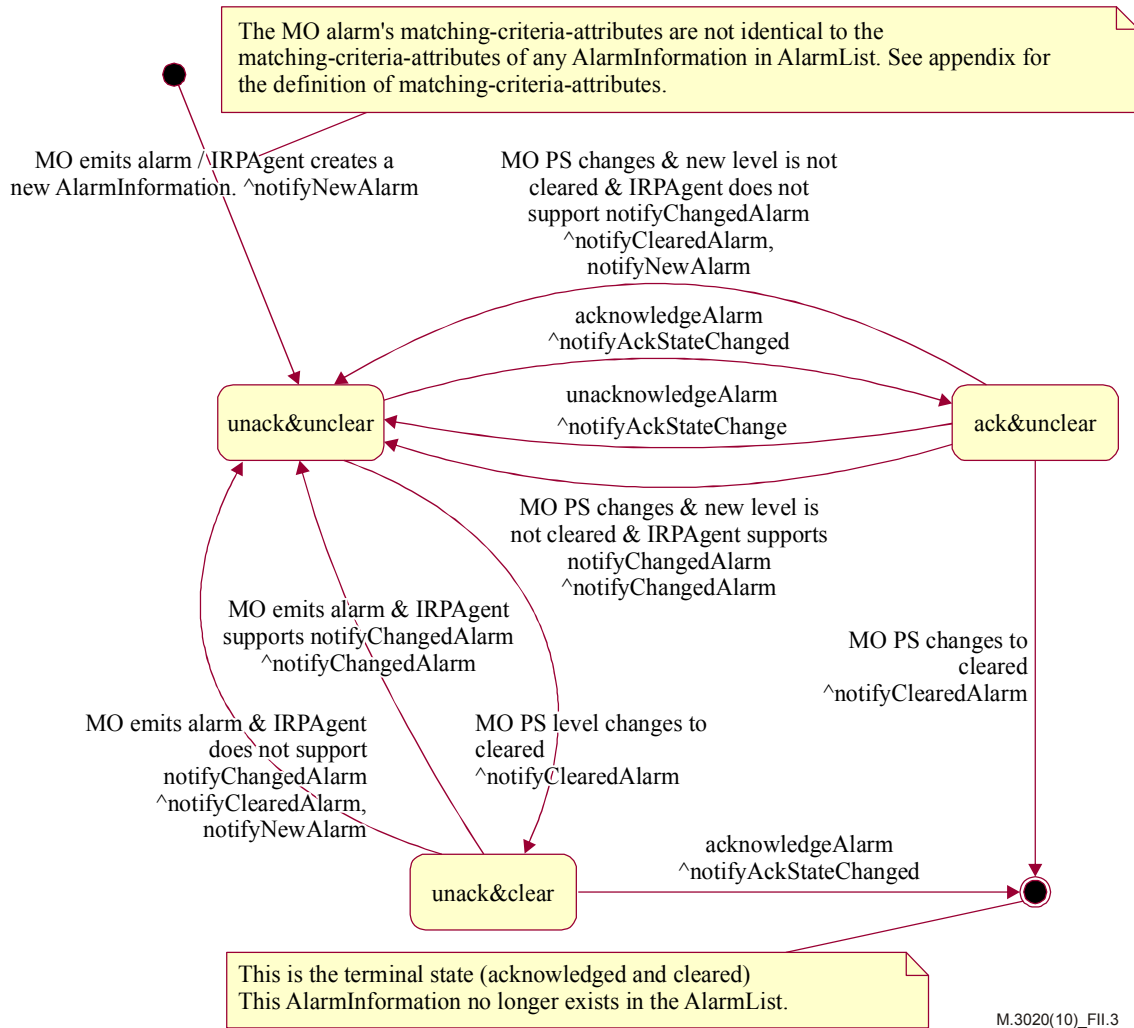

Figure II.3 – Alarm information state diagram

2.3.2 AlarmList

2.4 Information relationships definition

Relationship	Support qualifier	Requirement IDs
relation-AlarmIRP-AlarmList	M	REQ-FM-FUN-x
...		

2.4.1 relation-AlarmIRP-AlarmList (M)

2.4.1.1 Definition

This represents the relationship between AlarmIRP and AlarmList.

2.4.1.2 Roles

Name	Definition
identifyAlarmIRP	It represents the capability to obtain the identities of one or more AlarmIRP.
identifyAlarmList	It represents the capability to obtain the identity of one AlarmList.

2.4.1.3 Constraint

There is no constraint for this relationship.

2.4.2 relation-AlarmList-AlarmInformation (M)

...

2.5 Information attribute definition

2.5.1 Definition and legal values

Name	Definition	Information type/ Legal values
alarmed	It identifies one AlarmInformation in the AlarmList.	INTEGER
notificationId	It identifies the notification that carries the AlarmInformation.	INTEGER
ntfSubscriptionState	It indicates the activation state of a subscription	ENUMERATED/"suspended": the subscription is suspended. "notSuspended": the subscription is active.

2.5.2 Constraints

Name	Affected attribute(s)	Definition
inv_notificationId	notificationId	NotificationIds shall be chosen to be unique across all notifications of a particular managed object (representing the NE) throughout the time that alarm correlation is significant. The algorithm by which alarm correlation is accomplished is outside the scope of this IRP.

3 Interface definition

3.1 Class diagram representing interfaces

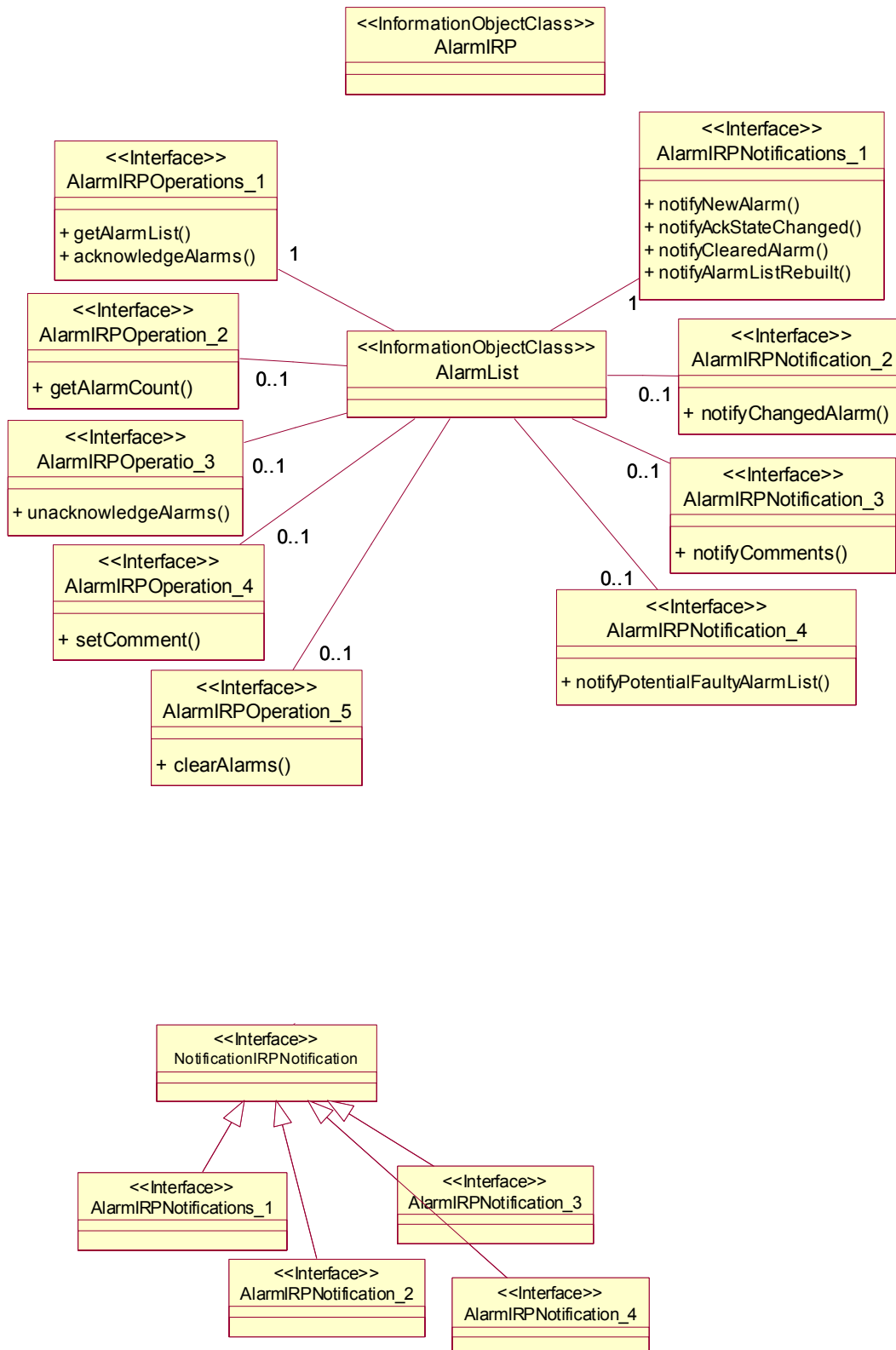

Figure II.4 – Alarm management IRP class diagram

3.2 Generic rules

Rule 1: Each operation with at least one input parameter supports a pre-condition `valid_input_parameter` which indicates that all input parameters shall be valid with regard to their information type. Additionally, each such operation supports an exception `operation_failed_invalid_input_parameter` which is raised when `valid_input_parameter` is false. The exception has the same entry and exit state.

Rule 2: Each operation with at least one optional input parameter supports a set of pre-conditions `supported_optional_input_parameter_xxx` where "xxx" is the name of the optional input parameter and the pre-condition indicates that the operation supports the named optional input parameter. Additionally, each such operation supports an exception `operation_failed_unsupported_optional_input_parameter_xxx` which is raised when:

- a) the pre-condition `supported_optional_input_parameter_xxx` is false; and
- b) the named optional input parameter is carrying information.

The exception has the same entry and exit state.

Rule 3: Each operation shall support a generic exception `operation_failed_internal_problem` that is raised when an internal problem occurs and that the operation cannot be completed. The exception has the same entry and exit state.

3.3 Interface AlarmIRPOperations_1 (O)

Operation Name	Qualifier	Requirement IDs
<code>acknowledgeAlarms</code>	M	REQ-FM-FUN-x, REQ-FM-FUN-y
<code>getAlarmList</code>	M	...

3.3.1 Operation `acknowledgeAlarms` (M)

3.3.1.1 Definition

The Manager invokes this operation to acknowledge one or more alarms.

3.3.1.2 Input parameters

Parameter Name	Support Qualifier	Information Type/Legal Values	Comment
...			
<code>eventIdList</code>	M	SET OF INTEGER/–	The list of alarms to be acknowledged.

3.3.1.3 Output parameters

Parameter Name	Support Qualifier	Matching Information/ Information Type/ Legal Values	Comment
...			
Status	M	-- / ENUM / "OperationSucceeded": If allAlarmsAcknowledged is true, "OperationPartiallySucceeded": If someAlarmAcknowledged is true, "OperationFailed": If operationFailed is true.	

3.3.1.4 Pre-condition

atLeastOneValidId.

Assertion Name	Definition
atLeastOneValidId	The AlarmInformationReferenceList contains at least one identifier that identifies one AlarmInformation in AlarmList, and that this identified AlarmInformation shall have its ackState indicating "unacknowledged" and, if provided, an equal perceivedSeverity.

3.3.1.5 Post-condition

someAlarmAcknowledged OR allAlarmsAcknowledged.

Assertion Name	Definition
someAlarmAcknowledged	...
allAlarmsAcknowledged	...

3.3.1.6 Exceptions

Name	Definition
operation_failed	Condition: Pre-condition is false or post-condition is false. Returned Information: The output parameter status. Exit state: Entry state.

3.3.2 Operation getAlarmList (M)

...

Appendix III

Comparison with Recommendation ITU-T Z.601

(This appendix does not form an integral part of this Recommendation)

This appendix provides information on the relationship between this Recommendation and [b-ITU-T Z.601] that is used for the development of Recommendations in the ITU-T M.1400 series of Recommendations.

While this Recommendation provides a methodology for specifying management interfaces between two physical systems, [b-ITU-T Z.601] provides a framework for the development of one system. This data architecture identifies candidate interfaces within one system as well as the interfaces on the boundary of this system. These interfaces at the boundary will be between systems.

The methodology specified by this Recommendation is primarily aimed at the development of a set of management interface Recommendations rather than of individual systems. The data architecture prescribes no requirements capture similar to the requirements phase, as it prescribes the specification of individual systems only, not their purpose relative to an organization.

[b-ITU-T Z.601] focuses on specification of the external terminology and grammar as perceived by the end users. This Recommendation focuses on specification of management interfaces, which may not be perceived by the end users.

In this Recommendation, the requirements for the problem being solved fall into two classes. The first class of requirements is referred to as business requirements; the second class is referred to as specification requirements. The specification requirements may include requirements to support end-user interaction at their human-computer interfaces. Some of these requirements may specify syntactical requirements to be supported over any management interface. Syntactical requirements correspond to external terminology schemata of the data architecture as described in [b-ITU-T Z.601].

The output of the analysis phase will be an information model. This corresponds to a concept schema of the data architecture as described in [b-ITU-T Z.601]. If the information models from the analysis phase do not convey all the necessary information from the syntactical requirements, the implementation design may need to include a mapping from the syntactical requirements.

The documentation from the implementation design phase will consist of two parts:

- 1) A technology-dependent data specification common for several interfaces, e.g., using GDMO or CORBA IDL, corresponding to an internal terminology schema according to the data architecture in [b-ITU-T Z.601].
- 2) A technology-dependent specification of each interface, e.g., using CMIP or CORBA IDL, corresponding to a distribution schema according to the data architecture in [b-ITU-T Z.601].

Appendix IV

Issues for further study

(This appendix does not form an integral part of this Recommendation)

This appendix identifies known issues that are subject for further study.

IV.1 SOA

The approval of [ITU-T M.3060] (Principles for the management of next generation networks) signalled a change from an object-oriented to a service-oriented approach to management. The impact of this change will need to be studied to identify any changes required in future revisions of this Recommendation.

IV.2 UML

This version of ITU-T M.3020 references UML version 1.5 in order to maintain alignment with the corresponding 3GPP specifications. A revised ITU-T M.3020 should reference later versions of UML:

- The OMG MOF meta-meta model integrates UML 2.x as a meta-model which is supported by the mainstream industry tool vendors. Prior to UML 2.0, there was no overarching meta-meta model and UML itself was not standard. MOF supports the addition and creation of other new meta-models defined in a precise way via OCL which is a predicate calculus language.
- Both industry (telecoms, governments and military) and tool vendors are converging on the OMG MOF model.
- The benefits of the MOF meta-meta model are that it supports a family of meta-models which can be used to define object models, HCI relationships, various technology-specific implementations and allows transformations between models to be undertaken in a standard way. This is not achievable in UML 1.5 since UML 1.5 exists in isolation of a higher meta-model.

IV.3 Visibility

It has been suggested that the default visibility should be private for attributes and public for operations in order to promote data encapsulation and reduce time and effort in defining the implementation model.

IV.4 Type definitions

When writing a new specification based on this methodology, it is necessary to specify the types of parameters and attributes. Formal type definitions are absent from the current version of this Recommendation, so the definition of types might be different and inconsistent for the same meaning in different specifications, e.g., for an array of integer, it might be defined as a list of integers, or a sequence of integers, or a set of integers.

Annex E defines the types that can be used in the conceptual model.

Appendix V

Additional UML usage samples

(This appendix does not form an integral part of this Recommendation)

This appendix contains additional samples on the use of the UML described in Annex C.

V.1 Proxy class

V.1.1 First sample

This shows a <<ProxyClass>> named YyyFunction. It represents all IOCs listed in the Note under the UML diagram. All the listed IOCs, in the context of this sample, inherit from ManagedFunction IOC.

The use of <<ProxyClass>> eliminates the need to draw multiple UML <<InformationObjectClass>> boxes, i.e., those whose names are listed in the Note, in the UML diagram.

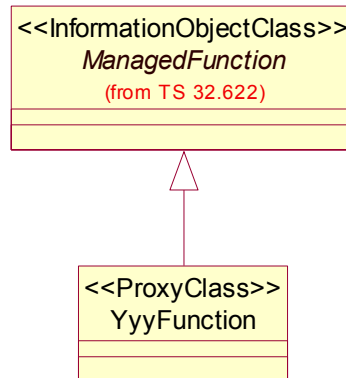

NOTE – The YyyFunction <<ProxyClass>> represents AsFunction, AucFunction, BgFunction, etc.

<<ProxyClass>> Notation sample V.1

V.1.2 Second sample

This shows a <<ProxyClass>> named YyyFunction. It represents all IOCs listed in the Note right under the UML diagram. All the listed IOCs, in the context of this sample, have link (internal and external) relations.

The actual names of the IOC represented by InternalYyyFunction <<ProxyClass>> and by the ExternalYyyFunction <<ProxyClass>> are listed under the subsection of X.Y of the associated YyyFunction. For example, under X.Y.1 for AsFunction, two paragraphs are added to list all peer internal entities and external entities that are linked with AsFunction. See sample in quotation below that is using AsFunction as a sample for YyyFunction.

The actual names of the IOC represented by Link_a_z <<ProxyClass>> and by ExternalLink_a_z <<ProxyClass>> are listed under the subsection of X.Y of the associated YyyFunction. For example, under X.Y.1 for AsFunction, two paragraphs are added to list the names of the IOCs represented by Link_a_z and by ExternalLink_a_z. See the quoted text below that is using AsFunction as a sample for YyyFunction.

"

X.Y.1 AsFunction

X.Y.1.1 Definition

This IOC represents As functionality. For more information about the As, see [b-3GPP TS 23.002].

The linked InternalYyyFunction <<ProxyClass>> represents SlsFunction, CscfFunction, HlrFunction ...

The linked ExternalYyyFunction <<ProxyClass>> represents ...

The Link_a_z <<ProxyClass>> represents Link_As_Scscf, Link_Bgcf_Scscf ...

The ExternalLink_a_z <<ProxyClass>> represents ...

"

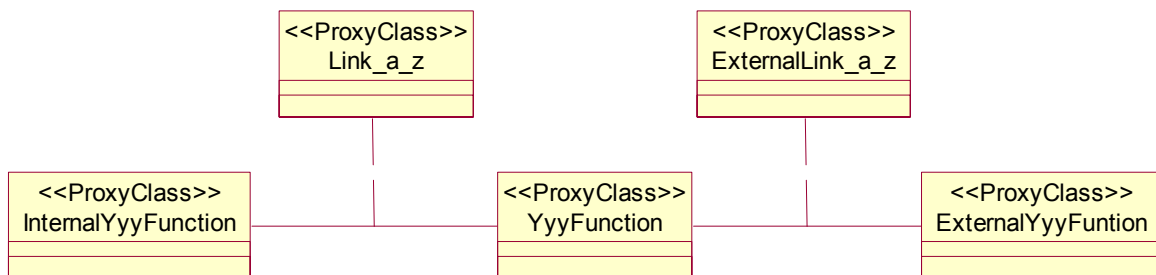

NOTE – The 'Yyy' of YyyFunction <<ProxyClass>> represents AsFunction, AucFunction, etc.

<<ProxyClass>> Notation sample V.2

Appendix VI

Guidelines on requirements numbering

(This appendix does not form an integral part of this Recommendation)

The format for requirements numbering is the following:

REQ-Label-Category-Number

where "Label" is an abbreviation for the Recommendation (or part thereof). The set of labels is not finite and not subject for standardization. The set of categories is defined in this Recommendation.

Some issues:

- How to structure the label in a large requirements specification?
- How to handle deletion and addition of requirements?

The following guidelines are found to be useful:

- Requirements should never be renumbered. The only exception to this case is the first publication of a specification, but even in this case it may be better to avoid renumbering as the specification may have been used also in its draft form.
- Given that requirements are not to be renumbered, it cannot be expected that the requirements are numbered sequentially throughout the specification.
- The label can be used to divide the numbering into logical partitions. As an example, the style of "A_B" is recommended to identify "B" as a logical partition of "A". However, other styles can be used as long as the structure with "-" separating the fields of the requirements number is maintained.
- Use of postfix or prefix notations, i.e., adding something in front of "Number" or following "Number", are not recommended since the "Number" part is not intended to convey semantic information.
- As an alternative to the "A_B" style, the authors of a specification may choose to assign a number range to a group of requirements. This approach should be allowed.

Bibliography

- [b-ITU-T M.1401] Recommendation ITU-T M.1401 (2006), *Formalization of interconnection designations among operators' telecommunication networks.*
- [b-ITU-T M.1403] Recommendation ITU-T M.1403 (2007), *Formalization of generic orders.*
- [b-ITU-T M.1404] Recommendation ITU-T M.1404 (2007), *Formalization of orders for interconnections among operators' networks.*
- [b-ITU-T Z.601] Recommendation ITU-T Z.601 (2007), *Data architecture of one software system.*
- [b-3GPP TS 23.002] 3GPP TS 23.002 (in force), *Network architecture.*
- [b-3GPP TS 32.101] 3GPP TS 32.101 V9.1.0 (2010), *Telecommunication management; Principles and high level requirements.*
- [b-3GPP TS 32.150] 3GPP TS 32.150 V9.1.0 (2010), *Telecommunication management; Integration Reference Point (IRP) Concept and definitions.*
- [b-3GPP TS 32.151] 3GPP TS 32.151 V9.3.0 (2010), *Telecommunication management; Integration Reference Point (IRP) Information Service (IS) template.*
- [b-3GPP TS 32.152] 3GPP TS 32.152 V9.2.0 (2010), *Telecommunication management; Integration Reference Point (IRP) Information Service (IS) Unified Modelling Language (UML) repertoire.*
- [b-3GPP TS 32.302] 3GPP TS 32.302 V9.0.0 (2009), *Telecommunication management; Configuration Management (CM); Notification Integration Reference Point (IRP); Information Service (IS).*

SERIES OF ITU-T RECOMMENDATIONS

Series A	Organization of the work of ITU-T
Series D	General tariff principles
Series E	Overall network operation, telephone service, service operation and human factors
Series F	Non-telephone telecommunication services
Series G	Transmission systems and media, digital systems and networks
Series H	Audiovisual and multimedia systems
Series I	Integrated services digital network
Series J	Cable networks and transmission of television, sound programme and other multimedia signals
Series K	Protection against interference
Series L	Construction, installation and protection of cables and other elements of outside plant
Series M	Telecommunication management, including TMN and network maintenance
Series N	Maintenance: international sound programme and television transmission circuits
Series O	Specifications of measuring equipment
Series P	Terminals and subjective and objective assessment methods
Series Q	Switching and signalling
Series R	Telegraph transmission
Series S	Telegraph services terminal equipment
Series T	Terminals for telematic services
Series U	Telegraph switching
Series V	Data communication over the telephone network
Series X	Data networks, open system communications and security
Series Y	Global information infrastructure, Internet protocol aspects and next-generation networks
Series Z	Languages and general software aspects for telecommunication systems