



INTERNATIONAL TELECOMMUNICATION UNION

ITU-T

TELECOMMUNICATION
STANDARDIZATION SECTOR
OF ITU

M.3611

(04/97)

SERIES M: TMN AND NETWORK MAINTENANCE:
INTERNATIONAL TRANSMISSION SYSTEMS,
TELEPHONE CIRCUITS, TELEGRAPHY, FACSIMILE
AND LEASED CIRCUITS

Integrated services digital networks

**Test management of the B-ISDN ATM layer
using the TMN**

ITU-T Recommendation M.3611

(Previously CCITT Recommendation)

ITU-T M-SERIES RECOMMENDATIONS

**TMN AND NETWORK MAINTENANCE: INTERNATIONAL TRANSMISSION SYSTEMS, TELEPHONE
CIRCUITS, TELEGRAPHY, FACSIMILE AND LEASED CIRCUITS**

Introduction and general principles of maintenance and maintenance organization	M.10–M.299
International transmission systems	M.300–M.559
International telephone circuits	M.560–M.759
Common channel signalling systems	M.760–M.799
International telegraph systems and phototelegraph transmission	M.800–M.899
International leased group and supergroup links	M.900–M.999
International leased circuits	M.1000–M.1099
Mobile telecommunication systems and services	M.1100–M.1199
International public telephone network	M.1200–M.1299
International data transmission systems	M.1300–M.1399
Designations and information exchange	M.1400–M.1999
International transport network	M.2000–M.2999
Telecommunications management network	M.3000–M.3599
Integrated services digital networks	M.3600–M.3999
Common channel signalling systems	M.4000–M.4999

For further details, please refer to ITU-T List of Recommendations.

ITU-T RECOMMENDATION M.3611

TEST MANAGEMENT OF THE B-ISDN ATM LAYER USING THE TMN

Summary

This Recommendation describes how the test of the B-ISDN ATM layer is managed through the TMN. This Recommendation identifies two types of ATM layer tests: non-intrusive loopback test and ATM layer performance test. For these test types, the required management functions and the architecture are clarified, and then management information is specified based on the X.745 model.

Source

ITU-T Recommendation M.3611 was prepared by ITU-T Study Group 4 (1997-2000) and was approved under the WTSC Resolution No. 1 procedure on the 19th of April 1997.

Keywords

Asynchronous Transfer Mode (ATM), B-ISDN, fault management, management information, performance management, Telecommunications Management Network (TMN), testing.

FOREWORD

ITU (International Telecommunication Union) is the United Nations Specialized Agency in the field of telecommunications. The ITU Telecommunication Standardization Sector (ITU-T) is a permanent organ of the ITU. The ITU-T is responsible for studying technical, operating and tariff questions and issuing Recommendations on them with a view to standardizing telecommunications on a worldwide basis.

The World Telecommunication Standardization Conference (WTSC), which meets every four years, establishes the topics for study by the ITU-T Study Groups which, in their turn, produce Recommendations on these topics.

The approval of Recommendations by the Members of the ITU-T is covered by the procedure laid down in WTSC Resolution No. 1.

In some areas of information technology which fall within ITU-T's purview, the necessary standards are prepared on a collaborative basis with ISO and IEC.

NOTE

In this Recommendation, the expression "Administration" is used for conciseness to indicate both a telecommunication administration and a recognized operating agency.

INTELLECTUAL PROPERTY RIGHTS

The ITU draws attention to the possibility that the practice or implementation of this Recommendation may involve the use of a claimed Intellectual Property Right. The ITU takes no position concerning the evidence, validity or applicability of claimed Intellectual Property Rights, whether asserted by ITU members or others outside of the Recommendation development process.

As of the date of approval of this Recommendation, the ITU had/had not received notice of intellectual property, protected by patents, which may be required to implement this Recommendation. However, implementors are cautioned that this may not represent the latest information and are therefore strongly urged to consult the TSB patent database.

© ITU 1997

All rights reserved. No part of this publication may be reproduced or utilized in any form or by any means, electronic or mechanical, including photocopying and microfilm, without permission in writing from the ITU.

CONTENTS

	Page
1	Scope..... 1
1.1	General..... 1
1.2	Relation to other Recommendations..... 1
2	References..... 1
3	Abbreviations..... 2
4	Configuration reference 2
5	Test management functions provided through the TMN for the ATM layer..... 3
6	Test description..... 8
6.1	Loopback test..... 8
6.2	ATM layer performance test..... 8
6.3	Management information associated with testing..... 8
7	Management information..... 8
7.1	Test categories 8
7.1.1	Loopback test category 8
7.1.2	ATM layer performance test category 8
7.2	Managed Objects 9
7.2.1	ATM layer performance test object..... 9
7.2.2	ATM loopback OAM access 9
7.2.3	ATM loopback test object 9
7.2.4	Connectivity OAM access..... 9
7.2.5	VP-VC OAM access..... 9
7.2.6	VP-VC test action performer..... 10
7.2.7	VP-VC test signal source..... 10
7.3	Attributes 10
7.3.1	Access point..... 10
7.3.2	Assigned test invocation..... 11
7.3.3	Associated object drop..... 11
7.3.4	Associated object generators 11
7.3.5	Associated object insertion..... 12
7.3.6	ATM test result..... 12
7.3.7	Connectivity OAM access identification..... 12
7.3.8	Loopback location identification..... 12
7.3.9	Measurement time 12
7.4	Parameters..... 12

	Page
7.4.1 ATM test result parameter	12
7.5 Relationships between Managed Objects	12
Annex A – Management information definitions	16
A.1 Test categories	16
A.2 Managed objects	17
A.3 Packages.....	19
A.4 Attributes	19
A.5 Parameters.....	21
A.6 Name Bindings.....	21
A.7 ASN.1 Module	21
Annex B – MOCS proforma	23
B.1 Introduction.....	23
B.2 Instructions for completing the MOCS proforma to produce a MOCS.....	23
B.3 Symbols, abbreviations and terms	24
B.4 ATM layer performance test object class.....	24
B.4.1 Statement of conformance to the managed object class	24
B.4.2 Packages	25
B.4.3 Attributes	26
B.4.4 Actions.....	27
B.4.5 Notifications	28
B.4.6 Parameters	29
B.5 ATM loopback OAM access object.....	29
B.5.1 Statement of conformance to the managed object class	29
B.5.2 Packages	29
B.5.3 Attributes	30
B.5.4 Actions.....	31
B.5.5 Notifications	31
B.5.6 Parameters	31
B.6 ATM loopback test object class.....	32
B.6.1 Statement of conformance to the managed object class	32
B.6.2 Packages	33
B.6.3 Attributes	34
B.6.4 Actions.....	35
B.6.5 Notifications	36

	Page
B.6.6 Parameters	37
B.7 Connectivity OAM access object class.....	37
B.7.1 Statement of conformance to the managed object class.....	37
B.7.2 Packages	37
B.7.3 Attributes	38
B.7.4 Actions.....	38
B.7.5 Notifications	38
B.7.6 Parameters	38
B.8 VP-VC OAM access object class	39
B.8.1 Statement of conformance to the managed object class.....	39
B.8.2 Packages	39
B.8.3 Attributes	40
B.8.4 Actions.....	40
B.8.5 Notifications	40
B.8.6 Parameters	40
B.9 VP-VC test action performer object class.....	41
B.9.1 Statement of conformance to the managed object class.....	41
B.9.2 Packages	41
B.9.3 Attributes	42
B.9.4 Actions.....	43
B.9.5 Notifications	43
B.9.6 Parameters	43
B.10 VP-VC test signal source object class	44
B.10.1 Statement of conformance to the managed object class.....	44
B.10.2 Packages	44
B.10.3 Attributes	45
B.10.4 Actions.....	45
B.10.5 Notifications	45
B.10.6 Parameters	45

Recommendation M.3611

TEST MANAGEMENT OF THE B-ISDN ATM LAYER USING THE TMN

(Geneva, 1997)

1 Scope

1.1 General

This Recommendation describes the testing aspects of ATM management functions using the TMN. It provides generic ATM test management information definitions. The management information is applied to the Q3 interface between equipment supporting OSF and equipment implementing Virtual Path/Channel (VP/VC) end points or VP/VC connecting points. The management information is based on the test management function specified in Recommendation X.745 [1].

1.2 Relation to other Recommendations

Recommendation M.3610 [2] describes principles and reference models for TMN management of B-ISDN in general. In this Recommendation, test management functions and management information definitions are derived for the ATM layer on the basis of the principles and the reference model discussed in Recommendation M.3610 [2].

Recommendations O.191 [3] and I.610 [4] specify the testing functions of network elements, which are managed by the TMN with using the method described in this Recommendation. Recommendation O.191 [3] presents the measurement mode, the OAM cell format, and the measurement algorithms used in the ATM layer performance test. Meanwhile, Recommendation I.610 [4] provides the mechanism of the non-intrusive loopback test.

This Recommendation addresses the test management of the ATM layer across TMN Q interfaces. The scope of this Recommendation is the management of temporal performance measurements, which are executed with using test cells. The management information model is specified on the basis of the X.745 model.

For semi-permanent performance measurements based on cell header information, the Q.822 [5] model may be used as a basis of management information. This type of performance measurements, for example, header error counting based on the HEC field, are not included in the scope of this Recommendation.

2 References

The following ITU-T Recommendations and other references contain provisions which, through reference in this text, constitute revisions of this Recommendation. At the time of publication, the editions indicated are valid. All Recommendations and other references are subject to revision; all users of this Recommendation are therefore encouraged to investigate the possibility of applying the most recent edition of the Recommendations and other references listed below. A list of the currently valid ITU-T Recommendations is regularly published.

- [1] ITU-T Recommendation X.745 (1993), *Information technology – Open Systems Interconnection – Systems management: Test management function.*
- [2] ITU-T Recommendation M.3610 (1996), *Principles for applying the TMN concept to the management of B-ISDN.*

- [3] ITU-T Recommendation O.191 (1997), *Equipment to assess ATM layer cell transfer performance.*
- [4] ITU-T Recommendation I.610 (1995), *B-ISDN operation and maintenance principles and functions.*
- [5] ITU-T Recommendation Q.822 (1994), *Stage 1, stage 2 and stage 3 description for the Q3 interface – Performance management.*
- [6] ITU-T Recommendation M.3207.1 (1996), *TMN management service: Maintenance aspects of B-ISDN management.*
- [7] ITU-T Recommendation M.1400 (1997), *Designations for international networks.*
- [8] ITU-T Recommendation X.737 (1995), *Information technology – Open Systems Interconnection – Systems management: Confidence and diagnostic test categories.*
- [9] ITU-T Recommendation M.3100 (1995), *Generic network information model.*

3 Abbreviations

This Recommendation uses the following abbreviations.

AME	ATM Measurement Equipment
ATM	Asynchronous Transfer Mode
MO	Managed Object
MORT	Managed Object Referring to Test
NEF	Network Element Function
OAM	Operation, Administration, and Maintenance
OSF	Operations Systems Function
TARR	Test Action Request Receiver
TMN	Telecommunications Management Network
VC	Virtual Channel
VCC	Virtual Channel Connection
VP	Virtual Path
VPC	Virtual Path Connection

4 Configuration reference

The ATM consists of the virtual channel level and the virtual path level. The entities to be managed are the virtual channel/path links and the virtual channel/path connections (see Figure 1). TMN management functions are accessible at the Q3 interfaces of equipment implementing virtual path and virtual channel end points and connecting points.

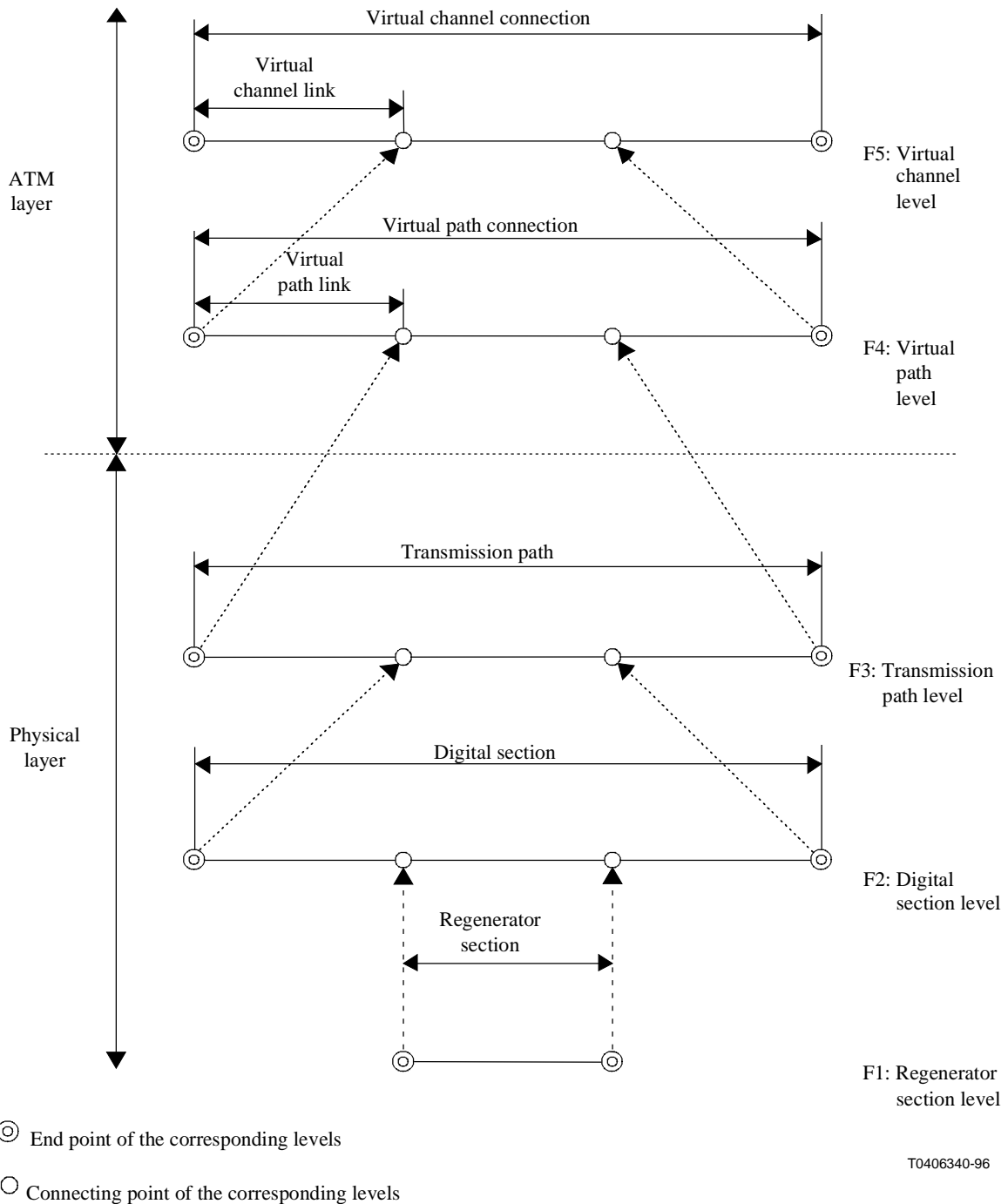

Figure 1/M.3611 – Entities to be managed in the ATM layer and physical layer

5 Test management functions provided through the TMN for the ATM layer

This clause lists test-related management functions for the ATM layer. These functions must be provided at the Q3 interfaces of equipment implementing virtual path/virtual channel end points and connecting points. The functions are imported from components that are described in Recommendation M.3207.1 [6].

1) *Non-intrusive loopback test function* (see Recommendation I.610)

The non-intrusive loopback test is executed through the mechanism specified in Recommendation I.610 [4]. This test is not executed by the test equipment described in Recommendation O.191 [3]. To manage the test, the following functions are provided by the TMN.

a) OSF requests NE to execute ATM non-intrusive loopback test.

The test request has to include:

- loopback location (see Recommendation M.1400 [7]) or indication for end-to-end measurement; and
- the identification of the trail termination function or the connection point that inserts and analyzes the loopback OAM cell.

b) NEF reports the results of non-intrusive loopback tests. The report has to include the results as well as the identification of the trail termination functions or the connection points of the subnetwork connection that performs the test.

c) OSF requests NEF to set conditions for the non-intrusive loopback test including duration, reporting frequency, etc. The request has to include the parameter values and the identification of the associated termination function or connection point.

Figure 2 shows the architecture for the non-intrusive loopback test function.

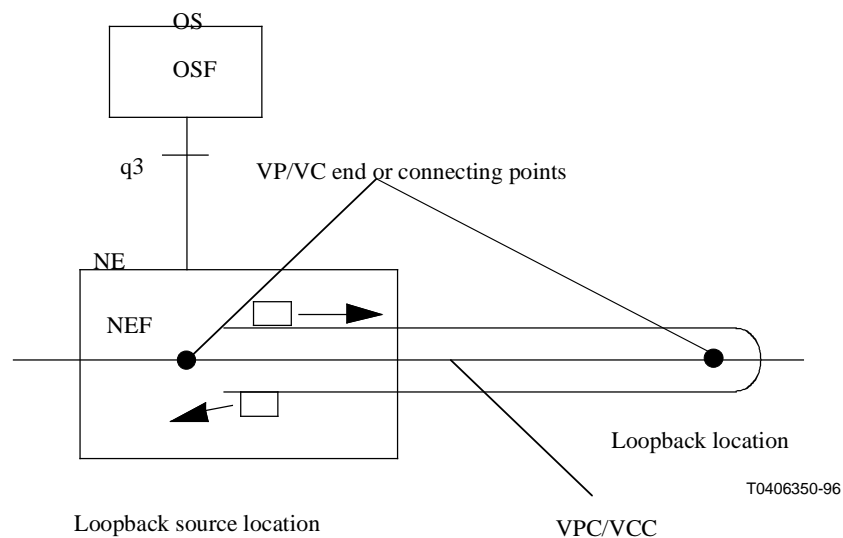

Figure 2/M.3611 – The architecture for the non-intrusive loopback test function

2) *ATM layer performance test* (see Recommendation O.191 [3])

The ATM layer performance test is executed by the test equipment specified in Recommendation O.191 [3]. To manage the test, the following functions are provided by the TMN.

a) OSF requests NEF to insert or drop test cells for ATM layer performance testing in the in-service, out-of-service, or drop-and-insert measurement mode. The request has to include the identification of the insertion or drop point for test signal. Such a point corresponds to a trail termination function or a connection point of the subnetwork connection of the virtual path/channel to be tested.

- b) OSF requests NEF to execute ATM layer performance testing, and NEF reports the results of ATM layer performance testing.
- c) OSF requests NEF to suspend/resume the ATM layer performance test on a particular virtual path/channel connection. The request has to include the test invocation identifier and the identification of the associated termination function or connection point.
- d) OSF requests NEF to set the threshold for the ATM layer performance test on a particular virtual path/channel connection. The request has to include the threshold values, the test invocation identifier, and the identification of the associated termination function or connection point.
- e) OSF requests NEF to terminate the ATM layer performance test on a particular virtual path/channel connection. The request has to include the test invocation identifier and the identification of the associated termination function or connection point.
- f) OSF asks NEF if the test is going on and requests NEF to report the status of the current test.

Figures 3 to 5 show the architectures for the performance test executed in the out-of-service measurement mode, the in-service measurement mode, and the drop-and-insert measurement mode.

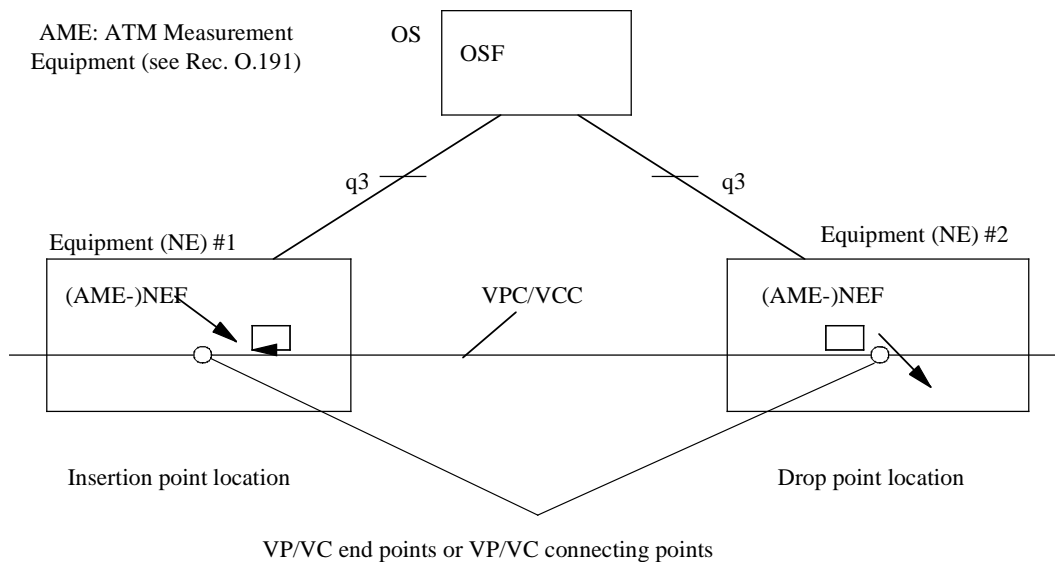

a) The case where AME-NEF is implemented in equipment including VP/VC end points or VP/VC connecting points

NOTE – AME function is supported in ATM switch/cross-connect NEs.

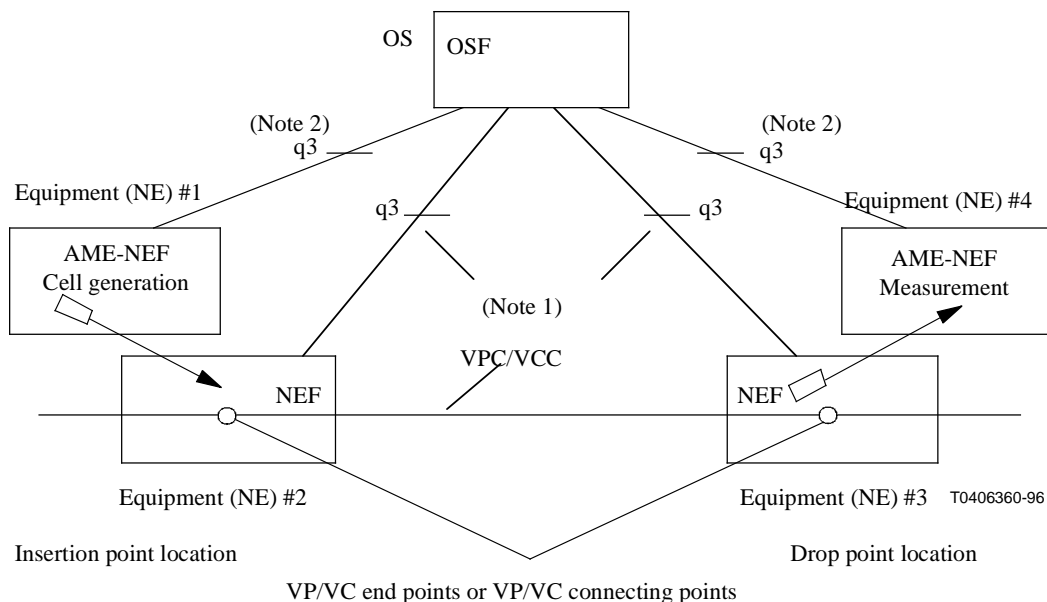

b) The case where AME-NEF is provided by equipment separate from that including VP/VC end points or VP/VC connecting points

NOTE 1 – Configuration management is supported across these q3 reference points to connect VP/VC to AME.

NOTE 2 – Test management and configuration management are supported across these q3 reference points.

Figure 3/M.3611 – The architecture for the ATM layer performance test function in the out-of-service measurement mode

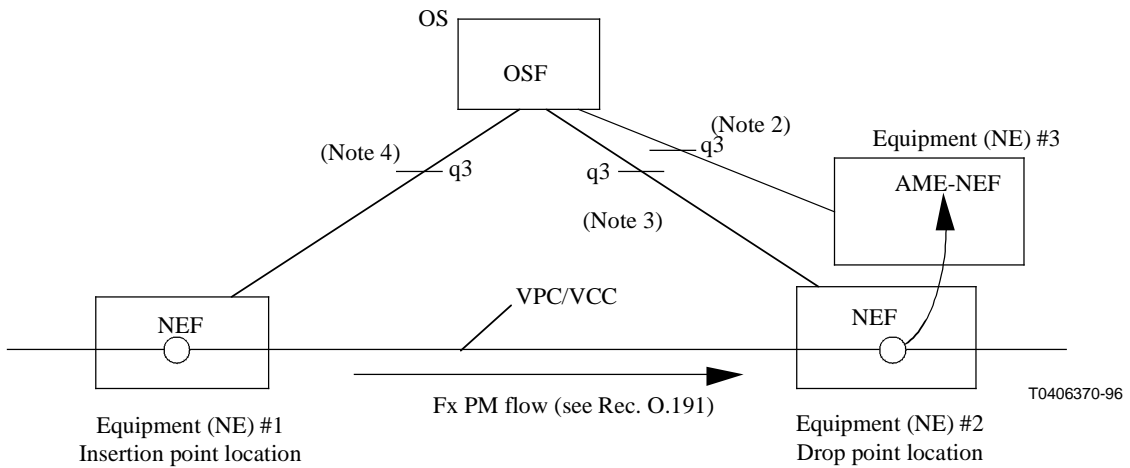

NOTE 1 – This figure shows the case where AME-NEF is not included in ATM switch/cross-connect NEs.
 NOTE 2 – Test management and configuration management are supported across this q3 reference point.
 NOTE 3 – Configuration management is supported across this q3 reference point to connect VP/VC to AME.
 NOTE 4 – Performance monitoring control is supported across this q3 reference point to start/stop Fx PM flow insertion.

Figure 4/M.3611 – The architecture for the ATM layer performance test function in the in-service measurement mode

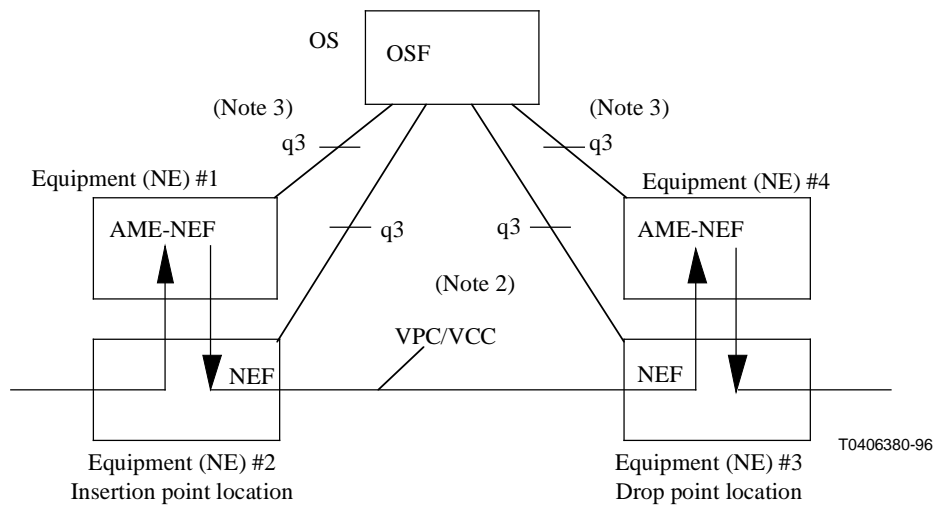

NOTE 1 – This figure shows the case where AME-NEF is not included in ATM switch/cross-connect NEs.
 NOTE 2 – Configuration management is supported across these q3 reference points to connect VP/VC to AME.
 NOTE 3 – Test management and configuration management are supported across these q3 reference points.

Figure 5/M.3611 – The architecture for the ATM layer performance test function in the drop-and-insert measurement mode

6 Test description

6.1 Loopback test

A loopback OAM cell is inserted at the loopback source location and the cell is loopbacked toward the source location at the loopback location specified within the OAM cell. The loopbacked OAM cell is dropped at the loopback source location. The test is non-intrusive.

6.2 ATM layer performance test

Recommendation O.191 [3] defines the equipment specification needed for ATM layer performance testing. It includes testing with out-of-service, in-service and drop-and-insert measurement modes.

6.3 Management information associated with testing

The management information model must be defined to meet the following requirements.

- To perform long-term testing flexibly, suspension, resumption, and forcible termination must be provided.
- Management information must be able to accommodate multiple managed systems involved in a test to examine a virtual path/channel connection.
- The testing environment must be set in an appropriate order to allow the insertion of test signals during measurement and to not have the test signals passed to users.
- Concurrency control must be provided for managed objects to manipulate concurrent test requests on the same resource.

Management information should be determined according to Recommendations X.745 [1] and X.737 [8]. Thus, the following must be defined for each type of testing.

- Test Category.
- Test Object.
- Managed Object Referring to Test (MORT).
- Managed Object with Test Action Request Receiver (TARR).
- Associated Object.

7 Management information

7.1 Test categories

7.1.1 Loopback test category

Loopback test category is a test category defined for loopback test in Recommendation X.737 [8].

7.1.2 ATM layer performance test category

ATM layer performance test category defines a test category needed to perform ATM layer performance test.

7.2 Managed Objects

7.2.1 ATM layer performance test object

ATM layer performance test object is a test object that conducts an ATM layer performance test based on test cell sending and receiving to/from particular VPC/VCC segment endpoints. This test object supports the out-of-service, in-service, and drop-and-insert measurement modes.

ATM layer performance test object is created by a test request received by an MO with TARR. The object reports the test result to the manager through a test result notification or the ATM test result attribute.

A newly-created instance of this managed object class enters the initializing state (see Recommendation X.745 [1]). When the assigned test invocation attribute of the associated VP-VC test action performer object is set to the test invocation id assigned to the instance, it becomes the testing state. The instance enters the terminating state when the measurement is over. The instance is deleted if the VP-VC test action performer object receives a test termination request.

7.2.2 ATM loopback OAM access

ATM loopback OAM access managed object class is a subclass of the VP-VC OAM access managed object class. This managed object class is used to manage the resource that transmits the loopback OAM cell and receives the returned cell transferred along a virtual path or channel connection. The loopback location field of the cell is determined by the ATM loopback location identification attribute. The VPI/VCI of the cell header is given by the managed object instance pointed to by the access point attribute.

The ATM loopback OAM access managed object class also inherits the test action performer managed object class specified in Recommendation X.745 [1]. Thus, the object is MO with TARR and receives the test action requests specified in Recommendation X.745 [1] (test request uncontrolled/controlled, test termination, or test suspend/resume).

7.2.3 ATM loopback test object

ATM loopback test object is a test object that conducts an ATM loopback test based on loopback OAM cell sending and receiving over particular VPC/VCC.

ATM loopback test object class is derived from "ITU-T Rec. X.737 | ISO/IEC 10164-14" : loopbackTestObject class. The class is defined in order to apply the X.737 loopback test category to the B-ISDN ATM layer. The behaviour of the class definition includes the method of judging the test outcome.

7.2.4 Connectivity OAM access

OAM signals are generated, inserted, extracted or analyzed for a specified connectivity according to information stored in an object instance of a subclass of the connectivity OAM access managed object class. The accessed connection may be specified by the termination point object instance pointed to by the access point attribute.

7.2.5 VP-VC OAM access

VP-VC OAM access managed object class is a subclass of the connectivity OAM access managed object class. F4 or F5 OAM cells are generated, inserted, extracted or analyzed for a specified VPC/VCC or its segment according to information stored in an object instance of a subclass of the VP-VC OAM access managed object class.

7.2.6 VP-VC test action performer

VP-VC test action performer managed object class is a subclass of the VP-VC OAM access managed object class. A subclass of this managed object class is used to manage the test cell analysis. For this purpose, the measurement time attribute is defined for the managed object class. The subclass may include additional attributes for test cell analysis as well as for test cell extraction. An example of such an attribute is the measurement mode.

The VP-VC test action performer managed object class is also inherited from the test action performer managed object class specified in Recommendation X.745 [1]. Thus, the object is MO with TARR and receives the test action requests specified in Recommendation X.745 [1] (test request controlled, test termination, or test suspend/resume).

The measurement starts if the assigned test invocation attribute is set to the value assigned to the test. To set this attribute, an ATM layer performance test object instance must be created by the test request beforehand. If the ATM layer performance test object instance is deleted, the assigned test invocation attribute shall be set to the default value as a side effect of the deletion.

7.2.7 VP-VC test signal source

VP-VC test signal source managed object class is a subclass of the VP-VC OAM access managed object class. A subclass of this managed object class is used to manage the test cell generation and test cell insertion functions. Typically, the subclass has the attributes that specify the measurement mode (out-of-service, in-service or drop-and-insert, see Recommendation O.191 [3]) and the traffic condition.

Test cells are not inserted if the access point attribute is set to the default value. Otherwise, test cells are inserted.

7.3 Attributes

7.3.1 Access point

The value of the access point attribute is a sequence of an object instance and an identifier of the signal direction. The object instance indicated in the attribute value is the instance of a termination point object class, which represents the OAM signal access point. That is, the OAM signal is inserted to or extracted from the point represented by the object. The attribute value also shows the direction of the inserted or extracted OAM signal. If the termination point is bidirectional, the signal direction must be specified. As shown in Figure 6, the value of the signal direction can be "in" or "out", depending on whether the signal passes the cross-connection in the network element or not. If the termination point is not bidirectional, the signal direction value is not used.

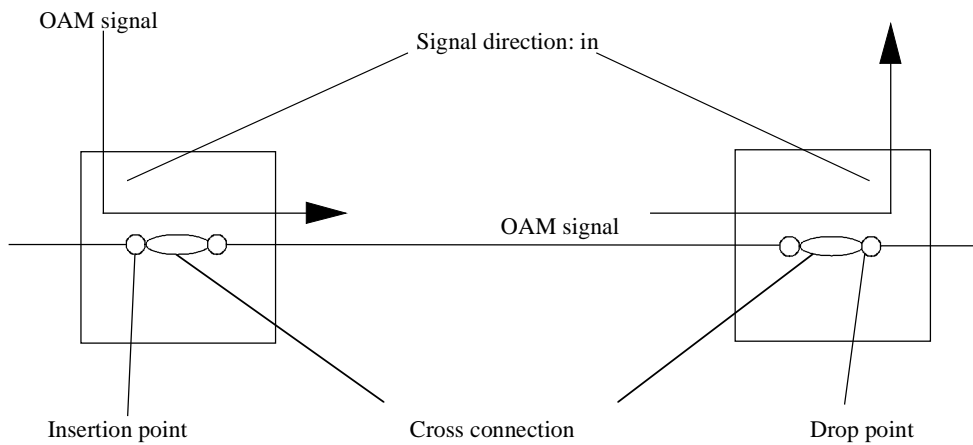

a) Case where the signal direction values are "in" for the insertion and drop points

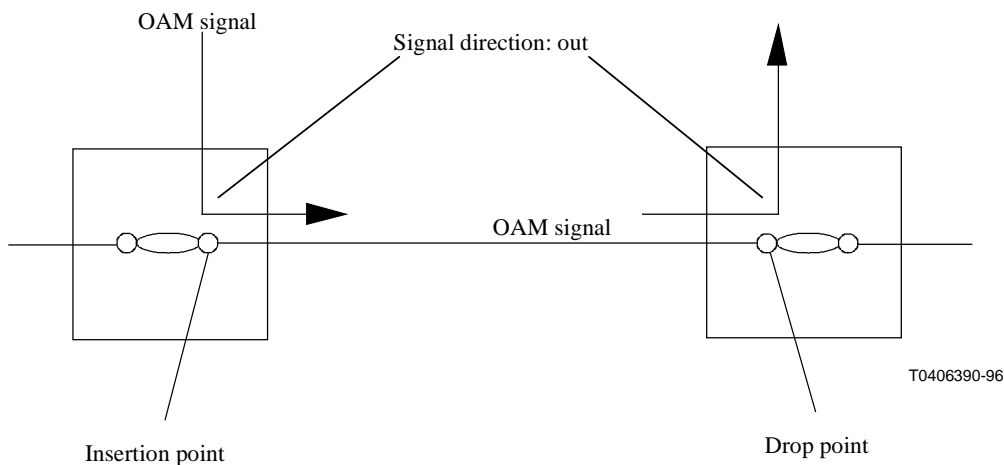

b) Case where the signal direction values are "out" for the insertion and drop points

Figure 6/M.3611 – The OAM signal direction indicated by the value of the access point attribute

7.3.2 Assigned test invocation

This attribute shows the test invocation id (see Recommendation X.745 [1]) that is now using the test cell analysis resource.

7.3.3 Associated object drop

This attribute has a list of pointers to associated objects that control test cell drop.

The attribute value type is the set of object instance and optional associated object information as in the associated object attribute defined in Recommendation X.745 [1].

7.3.4 Associated object generators

This attribute has a list of pointers to associated objects that control test cell generation for background virtual channels.

The attribute value type is the set of object instance and optional associated object information as in the associated object attribute defined in Recommendation X.745 [1].

7.3.5 Associated object insertion

This attribute has a list of pointer to associated objects that control test cell insertion.

The attribute value type is the set of object instance and optional associated object information as in the associated object attribute defined in Recommendation X.745 [1].

7.3.6 ATM test result

ATM test result attribute represents the results of ATM layer performance test. According to Recommendation O.191 [3], the following parameters must be measured by ATM measurement equipment.

- Cell Error Ratio.
- Cell Loss Ratio.
- Severely Errored Cell Block Ratio.
- Cell Misinsertion Ratio.
- Cell Transfer Delay.
- Cell Delay Variation.

These parameters can be derived from the value of ATM test result attribute.

The measurement of the parameters is optional; some parameters may be omitted from the measurement. Cell Transfer Delay and Cell Delay Variation are represented in milliseconds. The other parameters are represented by a real number.

7.3.7 Connectivity OAM access identification

This attribute is used to identify an instance of a subclass of the connectivity OAM access managed object class. The value of this attribute is an integer number.

7.3.8 Loopback location identification

This attribute is the value of the Loopback Location ID field of the OAM loopback cell to be generated. The attribute value type is the octet string of 16 bytes.

7.3.9 Measurement time

This attribute specifies the time during which the test is executed. The value is represented by an integer sequence, an element of which corresponds to days, hours, minutes, seconds or milliseconds.

7.4 Parameters

7.4.1 ATM test result parameter

This parameter is used as the additional information parameter in the test result notification, when the unsolicited reporting scheme is employed in the ATM layer performance test. The parameter shows the measured value list for the performance parameter.

7.5 Relationships between Managed Objects

Figure 7 illustrates the inheritance relationship among the managed objects employed in non-intrusive loopback test. The naming schema for these objects is shown in Figure 8. Figure 9 depicts message exchanges executed with using the model.

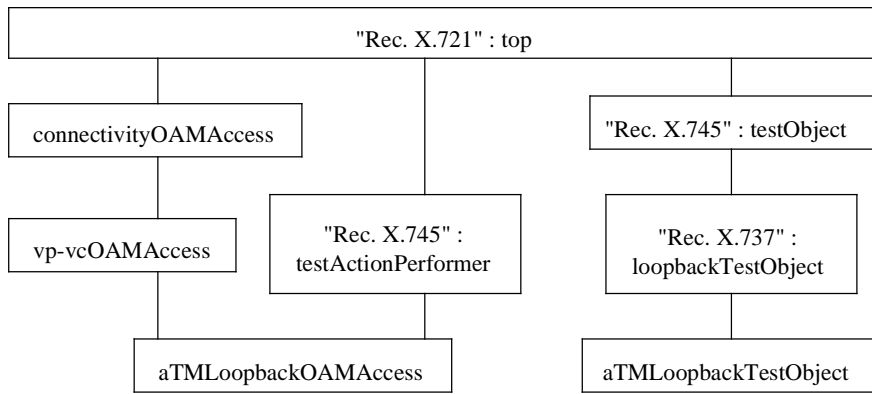

T0406400-96

Figure 7/M.3611 – Inheritance tree for the managed object classes defined for non-intrusive loopback test

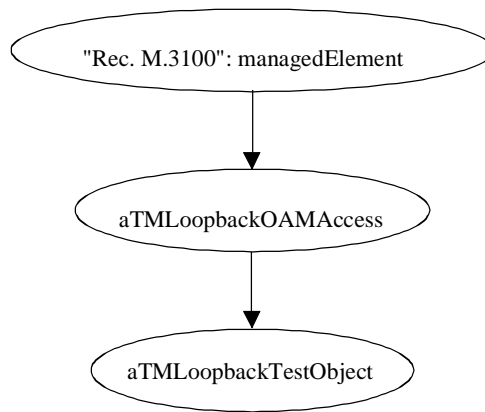

T0406410-96

Figure 8/M.3611 – Naming schema for non-intrusive loopback test

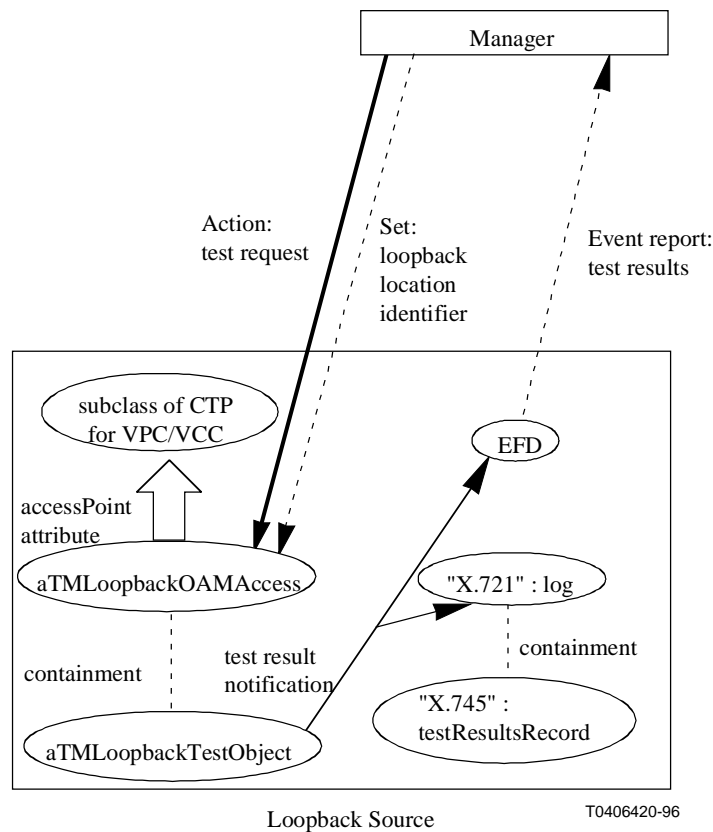

CTP Connection Termination Point (see Rec. M.3100)
 EFD Event Forwarding Discriminator (see Rec. X.721)

Figure 9/M.3611 – Message exchanges for non-intrusive loopback test

Figure 10 shows the inheritance tree for the managed object classes defined for ATM layer performance test. The naming schema for these objects is shown in Figure 11. Figures 12 and 13 depict message exchanges executed with using the objects for the out-of-service/drop-and-insert measurement mode and the in-service measurement mode.

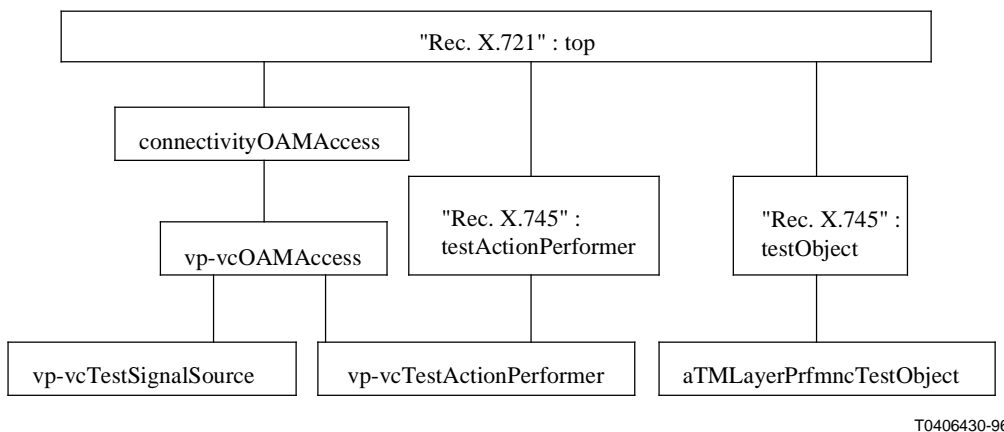
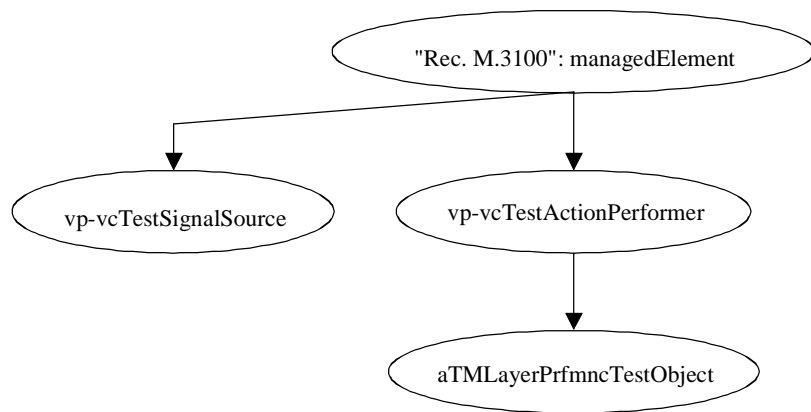
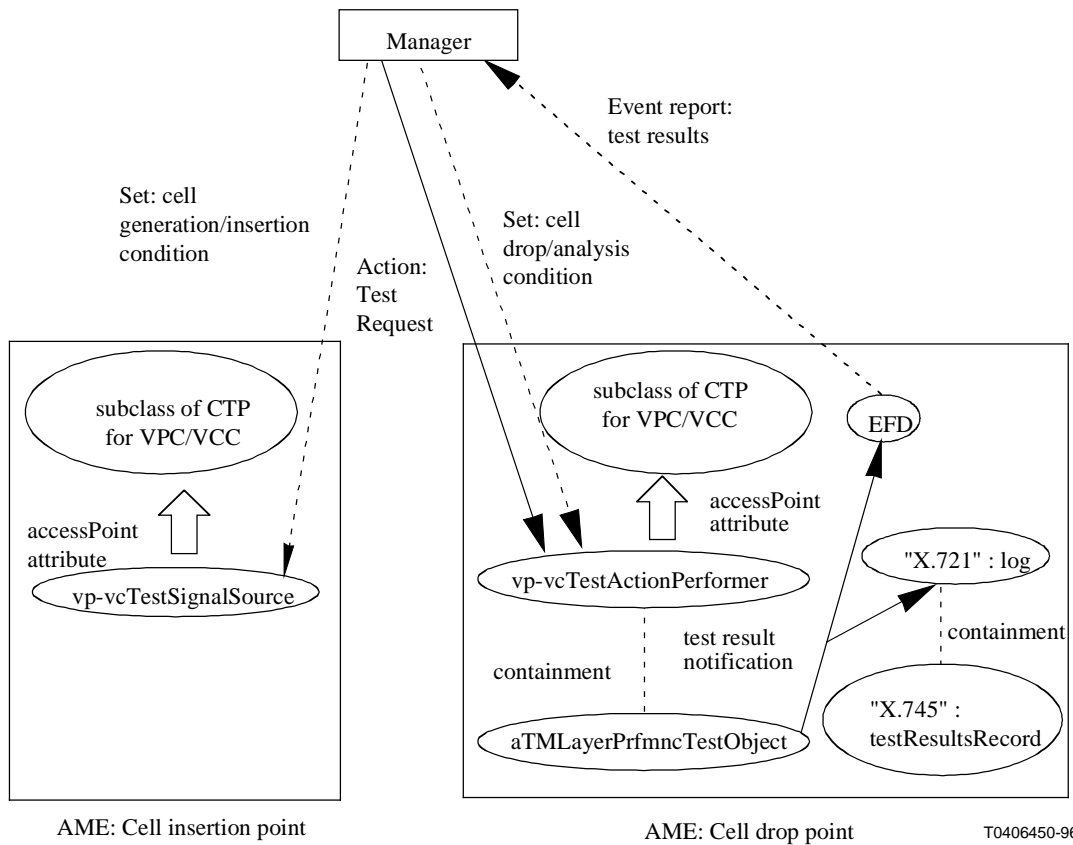

Figure 10/M.3611 – Inheritance tree for the managed object classes defined for ATM layer performance test



T0406440-96

Figure 11/M.3611 – Naming schema for ATM layer performance test



T0406450-96

CTP Connection Termination Point (see Rec. M.3100)
 EFD Event Forwarding Discriminator (see Rec.X.721)

Figure 12/M.3611 – Message exchanges for ATM layer performance test: out-of-service/drop-and-insert measurement mode

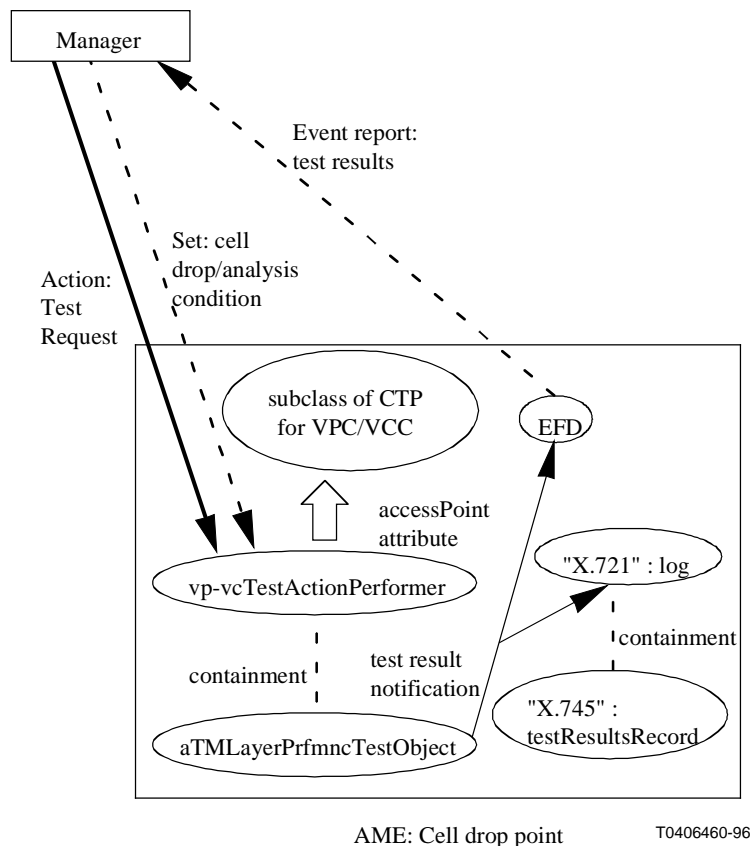

CTP Connection Termination Point (see Rec. M.3100)
 EFD Event Forwarding Discriminator (see Rec. X.721)

Figure 13/M.3611 – Message exchanges for ATM layer performance test: in-service measurement model

ANNEX A

Management information definitions

A.1 Test categories

The following test categories are necessary for management of the ATM layer.

1) *Loopback test category*

See Recommendation X.737.

For loopback tests in the B-ISDN ATM layer, MORT(s) represents a specified VPC/VCC or a specified segment of a VPC/VCC. Test object class aTMLoopbackTestObject is defined for the ATM layer loopback as a subclass of the loopbackTestObject specified in Recommendation X.737.

2) *ATM layer performance test category*

a) Test category name: ATM layer Performance Test.

b) Test category purpose: This test category is used to verify that the values of performance parameters of a specified VPC/VCC or its segment are not greater than specified thresholds. The test cell access for the VPC/VCC can be either out-of-service

measurements mode, in-service measurements mode or drop-and-insert measurements mode. For drop-and-insert and in-service measurements, the performance of a particular connection is measured. Care should be taken not to unduly disrupt user traffic, particularly if throughput testing is done. For out-of-service measurements, the performance of the network between the points is measured. In the latter case, the test is executed to certify that equipment providing VPC/VCC works correctly.

- c) MORT requirements: MORT(s) represents the VPC/VCC or its components in which test cells are transmitted.
- d) Associated object requirements: This test category uses at least one associated object. The associated object represents the resource that generates and inserts test cells. Optionally, additional associated objects may be used to load traffic to background VPCs/VCCs. These optional associated objects represent background VPCs/VCCs and resources generating traffic load.
- e) TARR requirements:
 - e1) Test request service type: testRequestControlledAction.
 - e2) Specific errors:
 - Test request controlled action: NoSuchMORT, MORTNotAvailable, MistypedTestCategoryInformation, IndependentTestInvocationError, RelatedTOError
 - Test suspend/resume action: InvalidTestOperation, NoSuchTestInvocationId, NoSuchTestSessionId, TestSuspendResumeError
 - Test termination action: InvalidTestOperation, NoSuchTestInvocationId, NoSuchTestSessionId, TestTerminateError
 - e3) Test category information parameter: No particular test category information parameter is necessary for this test category.
 - e4) Additional information parameter:
 - Test result notification additional information parameter: aTMTestResultParam.
 - e5) Test control: Test suspension/resumption and Test termination.
- f) TO requirements: This test category employs a test object to summarize performance parameters.
 - f1) TO class: aTMLayerPrfmncTestObject.

A.2 Managed objects

aTMLayerPrfmncTestObject **MANAGED OBJECT CLASS**
DERIVED FROM "Recommendation X.745 | ISO/IEC 10164-12: 1992" : testObject;
CHARACTERIZED BY aTMLayerPrfmncTestPkg **PACKAGE**
BEHAVIOUR aTMLayerPrfmncTestBehaviour **BEHAVIOUR**
DEFINED AS "The aTMLayerPrfmncTestObject is the test object defined for ATM layer performance testing.

If aTMLayerPrfmncTestResultPkg is present, the test result is stored in the aTMTestResults attribute. Otherwise, the test result is reported through the test result notification. See also 7.2.1.";;;

CONDITIONAL PACKAGES

backgroundLoadPkg **PRESENT IF** "the background traffic load is specified in the test request.",
aTMLayerPrfmncTestResultPkg **PRESENT IF** "the solicited reporting is supported, or testSuspendResumePackage is presented.",

aTMLayerTestAOPkg PRESENT IF "the manager requires it.";
REGISTERED AS {m3611ObjectClass 1};

aTMLoopbackOAMAccess MANAGED OBJECT CLASS
DERIVED FROM vp-vcOAMAccess,
"Recommendation X.745 | ISO/IEC 10164-12" : testActionPerformer;
CHARACTERIZED BY aTMLoopbackOAMAccessPkg PACKAGE
BEHAVIOUR aTMLoopbackOAMAccessBehaviour BEHAVIOUR
DEFINED AS "See 7.2.2.";;
ATTRIBUTES loopbackLocationID
REPLACE-WITH-DEFAULT DEFAULT VALUE
M3611-ASN1Module.allIsIn16octets
GET-REPLACE;;;
REGISTERED AS {m3611ObjectClass 2};

aTMLoopbackTestObject MANAGED OBJECT CLASS
DERIVED FROM "Recommendation X.737 | ISO/IEC 10164-14: 1995" : loopbackTestObject;
CHARACTERIZED BY aTMLoopbackTestPkg PACKAGE
BEHAVIOUR aTMLoopbackTestBehaviour BEHAVIOUR
DEFINED AS " aTMLoopbackTestObject enters the *testing state* when the loopback cell is sent. The object enters the *terminating state* if it does not receive the loopbacked cell within 5 seconds, or if it receives the loopbacked cell.
When the testOutcomePackage conditional package is present, the value of the testOutcome attribute is determined as follows:
1) If the object is not in the *terminating state*, the value is inconclusive.
2) At the moment that the object enters the *terminating state*, the value is set pass or fail. If it enters the *terminating state* by receiving the loopbacked cell, then the value is set pass, else the value is set fail. After that, the value is unchanged.
When the testResultPkg conditional package is present, the object emits testResultNotification as soon as it enters the *terminating state*. The value of the testOutcome parameter in the notification is pass if the object enters the *terminating state* by receiving the loopbacked cell. Otherwise, the value is fail. ";;;;
REGISTERED AS {m3611ObjectClass 3};

connectivityOAMAccess MANAGED OBJECT CLASS
DERIVED FROM "Recommendation X.721 | ISO/IEC 10165-2" : top;
CHARACTERIZED BY connectivityOAMAccessPkg PACKAGE
BEHAVIOUR connectivityOAMAccessBehaviour BEHAVIOUR
DEFINED AS "See 7.2.4.";;
ATTRIBUTES connectivityOAMAccessID GET,
accessPoint
REPLACE-WITH-DEFAULT DEFAULT VALUE
M3611-ASN1Module.pointNotDefined
GET-REPLACE ;;;
REGISTERED AS {m3611ObjectClass 4};

vp-vcOAMAccess MANAGED OBJECT CLASS
DERIVED FROM connectivityOAMAccess;
CHARACTERIZED BY vp-vcOAMAccessPkg PACKAGE
BEHAVIOUR vp-vcOAMAccessBehaviour BEHAVIOUR
DEFINED AS "See 7.2.5.";;;;
REGISTERED AS {m3611ObjectClass 5};

vp-vcTestActionPerformer **MANAGED OBJECT CLASS**
DERIVED FROM **vp-vcOAMAccess,**
 "Recommendation X.745 | ISO/IEC 10164-12" : testActionPerformer;
CHARACTERIZED BY
 "Recommendation X.745 | ISO/IEC 10164-12" : controlledTestRequestPackage,
 vp-vcTestActionPerformerPkg **PACKAGE**
BEHAVIOUR **vp-vcTestActionPerformerBehaviour** **BEHAVIOUR**
 DEFINED AS "See 7.2.6.";;
ATTRIBUTES **assignedTestInvctn**
 REPLACE-WITH-DEFAULT DEFAULT VALUE
 M3611-ASN1Module.noInvctn
 GET-REPLACE,
 measurementTime
 REPLACE-WITH-DEFAULT DEFAULT VALUE
 M3611-ASN1Module.nullMsrmntTime
 GET-REPLACE;;;
REGISTERED AS {m3611ObjectClass 6};

vp-vcTestSignalSource **MANAGED OBJECT CLASS**
DERIVED FROM **vp-vcOAMAccess;**
CHARACTERIZED BY **vp-vcTestSignalSourcePkg** **PACKAGE**
 BEHAVIOUR **vp-vcTestSignalSourceBehaviour** **BEHAVIOUR**
 DEFINED AS "See 7.2.7.";;;
REGISTERED AS {m3611ObjectClass 7};

A.3 Packages

aTMLayerPrfmncTestResultPkg **PACKAGE**
BEHAVIOUR **aTMLayerPrfmncTestResultBehaviour** **BEHAVIOUR**
 DEFINED AS "The measured values of the performance parameters are stored in the attribute
 of this package.";;
ATTRIBUTES **aTMTestResults** **GET;**
REGISTERED AS{m3611Package 1};

aTMLayerTestAOPkg **PACKAGE**
BEHAVIOUR **aTMLayerTestAOBehaviour** **BEHAVIOUR**
 DEFINED AS "The associatedObjectInsertion attribute identifies the resource generating and
 inserting test cells. The associatedObjectDrop attribute identifies the resource that selects and
 drops test cells from the tested VPC/VCC. ";;
ATTRIBUTES **associatedObjectInsertion** **GET,**
 associatedObjectDrop **GET;**
REGISTERED AS {m3611Package 2};

backgroundLoadPkg **PACKAGE**
BEHAVIOUR **backgroundLoadBehaviour** **BEHAVIOUR**
 DEFINED AS "The associatedObjectsGenerators attribute identifies the managed object
 instances that manage background traffic.";;
ATTRIBUTES **associatedObjectsGenerators** **GET;**
REGISTERED AS{m3611Package 3};

A.4 Attributes

accessPoint **ATTRIBUTE**
WITH ATTRIBUTE SYNTAX
 M3611-ASN1Module.AccessPoint;
MATCHES FOR **EQUALITY;**
BEHAVIOUR **accessPointBehaviour** **BEHAVIOUR**

DEFINED AS "See 7.3.1.";;
REGISTERED AS {m3611Attribute 1};

assignedTestInvctn ATTRIBUTE
WITH ATTRIBUTE SYNTAX
M3611-ASN1Module.AssignedTestInvctn;
MATCHES FOR EQUALITY;
BEHAVIOUR assignedTestInvctnBehaviour BEHAVIOUR
DEFINED AS "See 7.3.2.";;
REGISTERED AS {m3611Attribute 2};

associatedObjectDrop ATTRIBUTE
DERIVED FROM "Recommendation X.745 | ISO/IEC 10164-12: 1992" : AssociatedObjects;
BEHAVIOUR associatedObjectDropBehaviour BEHAVIOUR
DEFINED AS "This attribute is a list of pointers to associated objects that control test cell drop.";;
REGISTERED AS {m3611Attribute 3};

associatedObjectsGenerators ATTRIBUTE
DERIVED FROM "Recommendation X.745 | ISO/IEC 10164-12: 1992" : AssociatedObjects;
BEHAVIOUR associatedObjectsGeneratorsBehaviour BEHAVIOUR
DEFINED AS "This attribute is a list of pointers to associated objects that control test cell
generation for background virtual channels.";;
REGISTERED AS {m3611Attribute 4};

associatedObjectInsertion ATTRIBUTE
DERIVED FROM "Recommendation X.745 | ISO/IEC 10164-12: 1992" : AssociatedObjects;
BEHAVIOUR associatedObjectInsertionBehaviour BEHAVIOUR
DEFINED AS "This attribute is a list of pointer to associated objects that control test cell
insertion.";;
REGISTERED AS {m3611Attribute 5};

aTMTTestResults ATTRIBUTE
WITH ATTRIBUTE SYNTAX
M3611-ASN1Module.ATMTTestResults;
MATCHES FOR EQUALITY;
BEHAVIOUR aTMTTestResultsBehaviour BEHAVIOUR
DEFINED AS "This attribute shows the measured values of performance parameters in the test. The
attribute lists only those parameters that are subject to the measurement and omits the
parameters that are not to be measured.";;
REGISTERED AS {m3611Attribute 6};

connectivityOAMAccessID ATTRIBUTE
WITH ATTRIBUTE SYNTAX
M3611-ASN1Module.ConnectivityOAMAccessID;
MATCHES FOR EQUALITY;
BEHAVIOUR connectivityOAMAccessIDBehaviour BEHAVIOUR
DEFINED AS "See 7.3.7.";;
REGISTERED AS {m3611Attribute 7};

loopbackLocationID ATTRIBUTE
WITH ATTRIBUTE SYNTAX
M3611-ASN1Module.LoopbackLocationID;
MATCHES FOR EQUALITY;
BEHAVIOUR loopbackLocationIDBehaviour BEHAVIOUR

DEFINED AS "See 7. 3. 8.";;
REGISTERED AS {m3611Attribute 8};

measurementTime ATTRIBUTE
WITH ATTRIBUTE SYNTAX
M3611-ASN1Module.MeasurementTime;
MATCHES FOR EQUALITY, ORDERING;
BEHAVIOUR measurementTimeBehaviour BEHAVIOUR
DEFINED AS "See 7.3.9.";;
REGISTERED AS {m3611Attribute 9};

A.5 Parameters

aTMTestResultParam PARAMETER
CONTEXT EVENT-INFO;
ATTRIBUTE aTMTestResults;
REGISTERED AS {m3611Parameter 1};

A.6 Name Bindings

connectivityOAMAccess-managedElement-NB NAME BINDING
SUBORDINATE OBJECT CLASS
connectivityOAMAccess AND SUBCLASSES;
NAMED BY SUPERIOR OBJECT CLASS
"Recommendation M.3100 : 1992": managedElement AND SUBCLASSES;
WITH ATTRIBUTE connectivityOAMAccessID;
CREATE;
DELETE DELETES-CONTAINED-OBJECTS;
REGISTERED AS {m3611NameBinding 1};

testObject-connectivityOAMAccess-NB NAME BINDING
SUBORDINATE OBJECT CLASS
"Recommendation X.745 | ISO/IEC 10164-12: 1992" : testObject
AND SUBCLASSES;
NAMED BY SUPERIOR OBJECT CLASS
connectivityOAMAccess AND SUBCLASSES;
WITH ATTRIBUTE testObjectId;
CREATE;
DELETE DELETES-CONTAINED-OBJECTS;
REGISTERED AS {m3611NameBinding 2};

A.7 ASN.1 Module

M3611-ASN1Module {itu-t(0) recommendation(0) m(13) m3611(3611) informationModel(0) asn1Modules(2)
m3611-ASN1Module(0)}

DEFINITIONS

IMPLICIT TAGS

::=

BEGIN

--EXPORTS everything

IMPORTS

Timespec, TestInvocationId

FROM Test-ASN1Module

{joint-iso-ccitt ms(9) function(2) part12(12) asn1Module(2) 0}

ObjectInstance

FROM CMIP-1;

-- Object identifiers

m3611InformationModel OBJECT IDENTIFIER ::=
 {itu-t(0) recommendation(0) m(13) m3611(3611) informationModel(0)}

m3611ObjectClass OBJECT IDENTIFIER ::=
 {m3611InformationModel managedObjectClass(3)}

m3611Package OBJECT IDENTIFIER ::=
 {m3611InformationModel package(4)}

m3611Parameter OBJECT IDENTIFIER ::=
 {m3611InformationModel parameter(5)}

m3611NameBinding OBJECT IDENTIFIER ::=
 {m3611InformationModel nameBinding(6)}

m3611Attribute OBJECT IDENTIFIER ::=
 {m3611InformationModel attribute(7)}

-- default value definitions

all1sIn16octets LoopbackLocationID ::= 'FFFFFFFFFFFFFFFFFFFFFFFFFFFFFFFF'

pointNotDefined AccessPoint ::= undefined : NULL

noInvctn AssignedTestInvctn ::= noTestInvctn : NULL

nullMsrmntTime MeasurementTime ::= {}

-- attribute types

LoopbackLocationID ::= OCTET STRING

ATMTestResults ::= SEQUENCE {
 totalCellNumber **INTEGER,**
 totalCellBlockNumber **[0] INTEGER OPTIONAL,**
 cellErrorRatio **[1] REAL OPTIONAL,**
 cellLossRatio **[2] REAL OPTIONAL,**
 severelyErroredCellBlockRatio **[3] REAL OPTIONAL,**
 cellMisinsertionRatio **[4] REAL OPTIONAL,**
 cellTransferDelay **[5] Timespec OPTIONAL,**
 cellDelayVariation **[6] Timespec OPTIONAL}**

ConnectivityOAMAccessID ::= INTEGER

AccessPoint ::= CHOICE {
 defined **[0] SEQUENCE {ObjectInstance, SignalDirection},**
 undefined **[1] NULL }**

SignalDirection ::= ENUMERATED {
 in (0), -- insertion before and extraction after the cross connection
 out (1)-- insertion after and extraction from the cross connection
 }

AssignedTestInvctn ::= CHOICE {
 noTestInvctn **NULL,**
 assignedTest **TestInvocationId }**

```

MeasurementTime ::= SEQUENCE {
    days      [0]  INTEGER,
    hours     [1]  INTEGER,      -- 0 to 23
    minutes   [2]  INTEGER,      -- 0 to 59
    seconds   [3]  INTEGER,      -- 0 to 59
    milliseconds [4]  INTEGER    -- 0 to 999
}

```

END

ANNEX B¹

MOCS proforma

B.1 Introduction

The purpose of this MOCS proforma is to provide a mechanism for a supplier of an implementation which claims conformance to a managed object class to provide conformance information in a standard form.

B.2 Instructions for completing the MOCS proforma to produce a MOCS

The supplier of the implementation shall state which items are supported in the tables below and if necessary provide additional information.

The following common notations, defined in ITU-T Rec. X.291 and ISO/IEC 9646-2 and ITU-T Rec. X.296 and ISO/IEC 9646-7, are used for the Status column:

- m mandatory;
- o optional;
- c conditional;
- x prohibited;
- not applicable or out of scope.

NOTE 1 – 'c', 'm', and 'o' are prefixed by "c:" when nested under a conditional or optional item of the same table.

NOTE 2 – 'o' may be suffixed by ".N" (where N is a unique number) for selectable options among a set of status values. Support of at least one of the choices (from the items with the same value of N) is required.

The following common notations, defined in ITU-T Rec. X.291 and ISO/IEC 9646-2 and ITU-T Rec. X.296 and ISO/IEC 9646-7, are used for the Support column:

- Y implemented;
- N not implemented;
- no answer required;
- Ig the item is ignored (i.e. processed syntactically but not semantically).

¹ **Copyright release for MOCS proforma**

Users of this Recommendation may freely reproduce the MOCS proforma in this Annex so that it can be used for its intended purpose and may further publish the completed MOCS.

B.3 Symbols, abbreviations and terms

The following abbreviations are used throughout the proformas:

dmi-pkg join-iso-ccitt ms(9) smi(3) part2(2) package(4)
dmi-att joint-iso-ccitt ms(9) smi(3) part2(2) attribute(7)
m3611-att itu-t(0) recommendation(0) m(13) m3611(3611) informationModel(0) attribute(7)
m3611-moc itu-t(0) recommendation(0) m(13) m3611(3611) informationModel(0) managedObjectClass(3)
m3611-par itu-t(0) recommendation(0) m(13) m3611(3611) informationModel(0) parameter(5)
m3611-pkg itu-t(0) recommendation(0) m(13) m3611(3611) informationModel(0) package(4)
x737-att join-iso-ccitt ms(9) function(2) part14(14) attribute(7)
x737-par join-iso-ccitt ms(9) function(2) part14(14) parameter(5)
x737-pkg join-iso-ccitt ms(9) function(2) part14(14) package(4)
x745-act join-iso-ccitt ms(9) function(2) part12(12) action(9)
x745-att join-iso-ccitt ms(9) function(2) part12(12) attribute(7)
x745-ntf join-iso-ccitt ms(9) function(2) part12(12) notification(10)
x745-par join-iso-ccitt ms(9) function(2) part12(12) parameter(5)
x745-pkg join-iso-ccitt ms(9) function(2) part12(12) package(4)

B.4 ATM layer performance test object class

B.4.1 Statement of conformance to the managed object class

See Table B.1.

Table B.1/M.3611 – Managed object class support

Index	Managed object class template label	Value of object identifier for the managed object class	Support of all mandatory features (Y/N)	Is the actual class the same as the managed object class to which conformance is claimed? (Y/N)
1	aTMLayerPrfmncTestObject	{ m3611-moc 1 }		

If the answer to the actual class question in the managed object class support table is no, the supplier of the implementation shall fill in the actual class support table below (see Table B.2):

Table B.2/M.3611 – Actual class support

Index	Managed object class template label for actual class	Value of object identifier for managed object class definition of actual class	Additional information
1			

B.4.2 Packages

See Table B.3.

Table B.3/M.3611 – Packages support

Index	Package template label	Value of object identifier for the package	Constraints and values	Status	Support	Additional information
1	topPackage	–	–	m		
2	packagesPackage	{dmi-pkg 16}	–	c1		
3	allomorphicPackage	{dmi-pkg 17}	–	c2		
4	testObjectPackage	{x745-pkg 11}	–	m		
5	testOutcomePackage	{x745-pkg 12}	–	c3		
6	testSessionPackage	{x745-pkg 14}	–	o		
7	testResultPackage	{x745-pkg 13}	–	c4		
8	associatedObjectsPackage	{x745-pkg 2}	–	o		
9	mORTsPackage	{x745-pkg 5}	–	o		
10	tOControlStatusPackage	{x745-pkg 18}	–	c5		
11	availabilityStatusPackage	{dmi-pkg 22}	–	o		
12	requestedWindowPackage	{x745-pkg 6}	–	o		
13	actualTestTimePackage	{x745-pkg 1}	–	o		
14	aTMLayerPrfmncTestPkg	–	–	m		
15	backgroundLoadPkg	{m3611-pkg 3}	–	o		
16	aTMLayerPrfmncTestResultPkg	{m3611-pkg 1}	–	c3		
17	aTMLayerTestAOPkg	{m3611-pkg 2}	–	o		
<p>c1: if B.3/3a or B.3/5a or B.3/6a or B.3/7a or B.3/8a or B.3/9a or B.3/10a or B.3/11a or B.3/12a or B.3/13a or B.3.15a or B.3/16a or B.3.17a then m else –.</p> <p>c2: if B.1/1b then – else m.</p> <p>c3: if B.3/7a then o else m.</p> <p>c4: if B.3/5a and B. 3/16a then o else m.</p> <p>c5: if B.3/2a then m else –.</p>						

B.4.3 Attributes

See Table B.4.

Table B.4/M.3611 – Attribute support

Index	Attribute template label	Value of object identifier for the attribute	Constraints and values	Set by create		Get	
				Status	Support	Status	Support
1	objectClass	{dmi-att 65}	–	–		m	
2	nameBinding	{dmi-att 63}	–	–		m	
3	packages	{dmi-att 66}	–	–		c6	
4	allomorphs	{dmi-att 50}	–	–		c7	
5	testObjectId	{x745-att 11}	–	–		m	
6	testInvocationId	{x745-att 10}	–	–		m	
7	operationalState	{dmi-att 35}	–	–		m	
8	proceduralStatus	{dmi-att 36}	–	–		m	
9	testOutcome	{x745-att 12}	–	–		c8	
10	testSessionId	{x745-att 13}	–	–		c9	
11	associatedObjects	{x745-att 3}	–	–		c10	
12	mORTs	{x745-att 6}	–	–		c11	
13	controlStatus	{dmi-att 34}	–	–		c12	
14	availabilityStatus	{dmi-att 33}	–	–		c13	
15	startTime	{dmi-att 68}	–	–		c14	
16	endTime	{x745-att 4}	–	–		c14	
17	actualStartTime	{x745-att 1}	–	–		c15	
18	actualStopTime	{x745-att 2}	–	–		c15	
19	associatedObjectsGenerators	{m3611-att 4}	–	–		c16	
20	aTMTTestResults	{m3611-att 6}	–	–		c17	
21	associatedObjectInsertion	{m3611-att 5}	–	–		c18	
22	associatedObjectDrop	{m3611-att 6}	–	–		c18	

c6: if B.3/2a then m else –.
c7: if B.3/3a then m else –.
c8: if B.3/5a then m else –.
c9: if B.3/6a then m else –.
c10: if B.3/8a then m else –.
c11: if B.3/9a then m else –.
c12: if B.3/10a then m else –.
c13: if B.3/11a then m else –.
c14: if B.3/12a then m else –.
c15: if B.3/13a then m else –.
c16: if B.3/15a then m else –.
c17: if B.3/16a then m else –.
c18: if B.3/17a then m else –.

Table B.4/M.3611 – Attribute support (concluded)

Index	Replace		Add		Remove		Set to default		Additional information
	Status	Support	Status	Support	Status	Support	Status	Support	
1	x		–		–		–		
2	x		–		–		–		
3	c19		c19		c19		c19		
4	c20		c20		c20		c20		
5	x		–		–		–		
6	x		–		–		–		
7	x		–		–		–		
8	x		–		–		–		
9	c21		–		–		–		
10	c22		–		–		–		
11	c23		c23		c23		c23		
12	c24		c24		c24		c24		
13	c25		c25		c25		c25		
14	c26		c26		c26		c26		
15	c14		–		–		c27		
16	c14		–		–		c14		
17	c28		–		–		c28		
18	c28		–		–		c28		
19	c29		c29		c29		c29		
20	c30		–		–		c30		
21	c31		c31		c31		c31		
22	c31		c31		c31		c31		
<p>c19: if B.3/2a then x else –. c20: if B.3/3a then x else –. c21: if B.3/5a then x else –. c22: if B.3/6a then x else –. c23: if B.3/8a then x else –. c24: if B.3/9a then x else –. c25: if B.3/10a then x else –. c26: if B.3/11a then x else –. c27: if B.3/12a then x else –. c28: if B.3/13a then x else –. c29: if B.3/15a then x else –. c30: if B.3/16a then x else –. c31: if B.3/17a then x else –.</p>									

B.4.4 Actions

There are no actions defined for this managed object.

B.4.5 Notifications

See Table B.5.

Table B.5/M.3611 – Notification support

Index	Notification template label	Value of object identifier for notification	Constraints and values	Status	Support		Additional information
					Confirmed	Non-confirmed	
1	schedulingConflictNotification	{x745-ntf 1}	–	c32			
2	testResultNotification	{x745-ntf 2}	–	c33			
c32: if B.3/12a then m else –.							
c33: if B.3/7a then m else –.							

Table B.5/M.3611 – Notification support (concluded)

Index	Subindex	Notification field name label	Value of object identifier of attribute type associated with field	Constraints and values	Status	Support	Additional information
1	1.1	testInvocationId	{x745-att 10}	–	c32		
	1.2	testSessionId	{x745-att 13}	–	c34		
	1.3	startTime	{dmi-att 68}	–	c32		
	1.4	endTime	{x745-att 4}	–	c32		
	1.5	actualStartTime	{x745-att 1}	–	c32		
	1.6	actualStopTime	{x745-att 2}	–	c32		
	1.7	additionalText	{dmi-att 7}	–	c34		
	1.8	additionalInformation	{dmi-att 6}	–	c34		
2	2.1	testInvocationId	{x745-att 10}	–	c33		
	2.2	testSessionId	{x745-att 13}	–	c35		
	2.3	testOutcome	{x745-att 12}	–	c33		
	2.4	mORTs	{x745-att 6}	–	c35		
	2.5	associatedObjects	{x745-att 3}	–	c35		
	2.6	monitoredAttributes	{dmi-att 15}	–	c35		
	2.7	proposedRepairActions	{dmi-att 19}	–	c35		
	2.8	additionalText	{dmi-att 7}	–	c35		
	2.9	additionalInformation	{dmi-att 6}	–	c33		
	2.10	notificationIdentifier	{dmi-att 16}	–	c36		
	2.11	correlatedNotifications	{dmi-att 12}	–	c37		
c34: if B.3/12a then o else –.							
c35: if B.3/7a then o else –.							
c36: if B.3/7a and B.5/2.11a then m else –.							
c37: if B.3/7a and B.5/2.10a then m else –.							

B.4.6 Parameters

See Table B.6.

Table B.6/M.3611 – Parameter support

Index	Parameter template label	Value of object identifier for the parameter	Constraints and values	Status	Support	Additional information
1	aTMTestResultParam	{m3611-par 1}	–	c38		
c38: if B.5/1a then m else –.						

B.5 ATM loopback OAM access object

B.5.1 Statement of conformance to the managed object class

See Table B.7.

Table B.7/M.3611 – Managed object class support

Index	Managed object class template label	Value of object identifier for the managed object class	Support of all mandatory features (Y/N)	Is the actual class the same as the managed object class to which conformance is claimed? (Y/N)
1	aTMLoopbackOAMAccess	{ m3611-moc 2}		

If the answer to the actual class question in the managed object class support table is no, the supplier of the implementation shall fill in the actual class support table below (see Table B.8):

Table B.8/M.3611 – Actual class support

Index	Managed object class template label for actual class	Value of object identifier for managed object class definition of actual class	Additional information
1			

B.5.2 Packages

See Table B.9.

Table B.9/M.3611 – Packages support

Index	Package template label	Value of object identifier for the package	Constraints and values	Status	Support	Additional information
1	topPackage	–	–	m		
2	packagesPackage	{dmi-pkg 16}	–	c39		
3	allomorphicPackage	{dmi-pkg 17}	–	c40		
4	connectivityOAMAccessPkg	–	–	m		
5	vp-vcOAMAccessPkg	–	–	m		
6	aTMLoopbackOAMAccessPkg	–	–	m		
7	testActionPerformerPackage	{x745-pkg 9}	–	m		
8	controlledTestRequestPackage	{x745-pkg 3}	–	m		
9	uncontrolledTestRequestPackage	{x745-pkg 19}	–	x		
10	testSuspendResumePackage	{x745-pkg 16}	–	o		
11	testTerminatePackage	{x745-pkg 17}	–	o		
12	supportedTOClassesPackage	{x745-pkg 7}	–	m		
13	supportedUncontrolledTestsPackage	{x745-pkg 8}	–	x		
c39: if B.9/3a or B.9/10a or B.9/11a then m else –.						
c40: if B.7/1b then – else m.						

B.5.3 Attributes

See Table B.10.

Table B.10/M.3611 – Attribute support

Index	Attribute template label	Value of object identifier for the attribute	Constraints and values	Set by create		Get	
				Status	Support	Status	Support
1	objectClass	{dmi-att 65}	–	–		m	
2	nameBinding	{dmi-att 63}	–	–		m	
3	packages	{dmi-att 66}	–	–		c41	
4	allomorphs	{dmi-att 50}	–	–		c42	
5	connectivityOAMAccessID	{m3611-att 7}	–	–		m	
6	accessPoint	{m3611-att 1}	–	–		m	
7	loopbackLocationID	{m3611-att 8}	–	–		m	
8	testActionPerformerId	{x745-att 9}	–	–		–	
9	supportedTOClasses	{x745-att 7}	–	–		m	
10	supportedUncontrolledTests	{x745-att 8}	–	–		–	
c41: if B.9/2a then m else –.							
c42: if B.9/3a then m else –.							

Table B.10/M.3611 – Attribute support (concluded)

Index	Replace		Add		Remove		Set to default		Additional information
	Status	Support	Status	Support	Status	Support	Status	Support	
1	x		–		–		x		
2	x		–		–		x		
3	c43		c43		c43		c43		
4	c44		c44		c44		c44		
5	x		–		–		x		
6	m		–		–		m		
7	m		–		–		m		
8	–		–		–		–		
9	x		x		x		x		
10	–		–		–		–		

c43: if B.9/2a then x else –.
c44: if B.9/3a then x else –.

B.5.4 Actions

See Table B.11.

Table B.11/M.3611 – Action support

Index	Action type template label	Value of object identifier for the action type	Sub-index	Information Reply	Constraints and values	Status	Support	Additional information
1	testRequestControlledAction	{x745-act 1}	1.1	Information	–	m		
			1.2	reply	–	m		
2	testSuspendResumeAction	{x745-act 2}	2.1	Information	–	c45		
			2.2	reply	–	c45		
3	testTerminateAction	{x745-act 3}	3.1	Information	–	c46		
			3.2	reply	–	c46		
4	testRequestUncontrolledAction	{x745-act 4}	4.1	Information	–	x		
			4.2	reply	–	x		

c45: if B.9/10a then m else –.
c46: if B.9/11a then m else –.

B.5.5 Notifications

There are no notifications defined for this managed object class.

B.5.6 Parameters

See Table B.12.

Table B.12/M.3611 – Parameter support

Index	Parameter template label	Value of object identifier for the parameter	Constraints and values	Status	Support	Additional information
1	noSuchMORT	{x745-par 7}	–	m		
2	mORTNotAvailable	{x745-par 5}	–	m		
3	mistypedTestCategoryInformation	{x745-par 4}	–	m		
4	noSuchAssociatedObject	{x745-par 6}	–	o		
5	associatedObjectNotAvailable	{x745-par 1}	–	o		
6	independentTestInvocationError	{x745-par 2}	–	m		
7	relatedTOError	{x745-par 10}	–	m		
8	invalidTestOperation	{x745-par 3}	–	c47		
9	noSuchTestInvocationId	{x745-par 8}	–	c47		
10	noSuchTestSessionId	{x745-par 9}	–	c47		
11	testSuspendResumeError	{x745-par 11}	–	c48		
12	testTerminateError	{x745-par 12}	–	c49		
13	loopbackTestInfoParam	{x737-par 12}	–	o		
14	loopbackUncontrolledResultsParam	{x737-par 11}	–	–		
c47: if B.11/2a or B.11/3a then m else –. c48: if B.11/2a then m else –. c49: if B.11/3a then m else –.						

B.6 ATM loopback test object class

B.6.1 Statement of conformance to the managed object class

See Table B.13.

Table B.13/M.3611 – Managed object class support

Index	Managed object class template label	Value of object identifier for the managed object class	Support of all mandatory features (Y/N)	Is the actual class the same as the managed object class to which conformance is claimed? (Y/N)
1	aTMLoopbackTestObject	{ m3611-moc 3 }		

If the answer to the actual class question in the managed object class support table is no, the supplier of the implementation shall fill in the actual class support table below (see Table B.14):

Table B.14/M.3611 – Actual class support

Index	Managed object class template label for actual class	Value of object identifier for managed object class definition of actual class	Additional information
1			

B.6.2 Packages

See Table B.15.

Table B.15/M.3611 – Packages support

Index	Package template label	Value of object identifier for the package	Constraints and values	Status	Support	Additional information
1	topPackage	–	–	m		
2	packagesPackage	{dmi-pkg 16}	–	c50		
3	allomorphicPackage	{dmi-pkg 17}	–	c51		
4	testObjectPackage	{x745-pkg 11}	–	m		
5	testOutcomePackage	{x745-pkg 12}	–	c52		
6	testSessionPackage	{x745-pkg 14}	–	o		
7	testResultPackage	{x745-pkg 13}	–	c53		
8	associatedObjectsPackage	{x745-pkg 2}	–	o		
9	mORTsPackage	{x745-pkg 5}	–	m		
10	tOControlStatusPackage	{x745-pkg 18}	–	c54		
11	availabilityStatusPackage	{dmi-pkg 22}	–	o		
12	requestedWindowPackage	{x745-pkg 6}	–	o		
13	actualTestTimePackage	{x745-pkg 1}	–	o		
14	loopbackTestPkg	–	–	m		
15	timeoutPeriodPkg	{x737-pkg 13}	–	o		
16	testConditionsPkg	{x737-pkg 12}	–	o		
17	dataUnitsPkg	{x737-pkg 4}	–	x		
18	resultIntervalPkg	{x737-pkg 10}	–	x		
19	loopbackResultsPkg	{x737-pkg 5}	–	m		
20	loopbackThresholdPkg	{x737-pkg 6}	–	x		
21	aTMLoopbackTestPkg	–	–	m		
<p>c50: if B.15/3a or B.15/5a or B.15/6a or B.15/7a or B.15/8a or B.15/10a or B.15/11a or B.15/12a or B.15/13a or B.15/15a or B.15/16a or B.15/18a then – else m.</p> <p>c51: if B.13/1b then – else m.</p> <p>c52: if B.15/7a then o else m.</p> <p>c53: if B.15/5a then o else m.</p> <p>c54: if B.9/10a then o else m.</p>						

B.6.3 Attributes

See Table B.16.

Table B.16/M.3611 – Attribute support

Index	Attribute template label	Value of object identifier for the attribute	Constraints and values	Set by create		Get	
				Status	Support	Status	Support
1	objectClass	{dmi-att 65}	–	–		m	
2	nameBinding	{dmi-att 63}	–	–		m	
3	packages	{dmi-att 66}	–	–		c55	
4	allomorphs	{dmi-att 50}	–	–		c56	
5	testObjectId	{x745-att 11}	–	–		m	
6	testInvocationId	{x745-att 10}	–	–		m	
7	operationalState	{dmi-att 35}	–	–		m	
8	proceduralStatus	{dmi-att 36}	–	–		m	
9	testOutcome	{x745-att 12}	–	–		c57	
10	testSessionId	{x745-att 13}	–	–		c58	
11	associatedObjects	{x745-att 3}	–	–		c59	
12	mORTs	{x745-att 6}	–	–		m	
13	controlStatus	{dmi-att 34}	–	–		c60	
14	availabilityStatus	{dmi-att 33}	–	–		c61	
15	startTime	{dmi-att 68}	–	–		c62	
16	endTime	{x745-att 4}	–	–		c62	
17	actualStartTime	{x745-att 1}	–	–		c63	
18	actualStopTime	{x745-att 2}	–	–		c63	
19	loopbackType	{x737-att 12}	–	–		m	
20	testPatterns	{x737-att 24}	–	–		m	
21	errorRatioReportType	{x737-att 8}	–	–		m	
22	timeoutPeriod	{x745-att 16}	–	–		c64	
23	testConditions	{x737-att 22}	–	–		c65	
24	dataUnits	{x737-att 6}	–	–		–	
25	resultInterval	{x737-att 18}	–	–		–	
26	loopbackResults	{x737-att 10}	–	–		m	
27	testThreshold	{x737-att 25}	–	–		–	
c55: if B.15/2a then m else –. c56: if B.15/3a then m else –. c57: if B.15/5a then m else –. c58: if B.15/6a then m else –. c59: if B.15/8a then m else –. c60: if B.15/10a then m else –. c61: if B.15/11a then m else –. c62: if B.15/12a then m else –. c63: if B.15/13a then m else –. c64: if B.15/15a then m else –. c65: if B.15/16a then m else –.							

Table B.16/M.3611 – Attribute support (concluded)

Index	Replace		Add		Remove		Set to default		Additional information
	Status	Support	Status	Support	Status	Support	Status	Support	
1	x		–		–		x		
2	x		–		–		x		
3	c66		c66		c66		c66		
4	c67		c67		c67		c67		
5	x		–		–		x		
6	x		–		–		x		
7	x		–		–		x		
8	x		–		–		x		
9	c68		–		–		c68		
10	c69		–		–		c69		
11	c70		c70		c70		c70		
12	x		x		x		x		
13	c71		c71		c71		c71		
14	c72		c72		c72		c72		
15	c62		–		–		c73		
16	c62		–		–		c62		
17	c74		–		–		c74		
18	c74		–		–		c74		
19	m		–		–		x		
20	m		–		–		x		
21	x		–		–		x		
22	c64		–		–		c64		
23	c65		–		–		c65		
24	–		–		–		–		
25	–		–		–		–		
26	x		–		–		x		
27	–		–		–		–		

c66: if B.15/2a then x else –.
c67: if B.15/3a then x else –.
c68: if B.15/5a then x else –.
c69: if B.15/6a then x else –.
c70: if B.15/8a then x else –.
c71: if B.15/10a then x else –.
c72: if B.15/11a then x else –.
c73: if B.15/12a then x else –.
c74: if B.15/13a then x else –.

B.6.4 Actions

There are no actions defined for this managed object class.

B.6.5 Notifications

See Table B.17.

Table B.17/M.3611 – Notification support

Index	Notification template label	Value of object identifier for notification	Constraints and values	Status	Support		Additional information
					Confirmed	Non-confirmed	
1	schedulingConflictNotification	{x745-ntf 1}	–	c75			
2	testResultNotification	{x745-ntf 2}	–	c76			
c75: if B.15/12a then m else –. c76: if B.15/7a then m else –.							

Table B.17/M.3611 – Notification support (concluded)

Index	Sub-index	Notification field name label	Value of object identifier of attribute type associated with field	Constraints and values	Status	Support	Additional information
1	1.1	testInvocationId	{x745-att 10}	–	c75		
	1.2	testSessionId	{x745-att 13}	–	c77		
	1.3	startTime	{dmi-att 68}	–	c75		
	1.4	endTime	{x745-att 4}	–	c75		
	1.5	actualStartTime	{x745-att 1}	–	c75		
	1.6	actualStopTime	{x745-att 2}	–	c75		
	1.7	additionalText	{dmi-att 7}	–	c77		
	1.8	additionalInformation	{dmi-att 6}	–	c77		
2	2.1	testInvocationId	{x745-att 10}	–	c76		
	2.2	testSessionId	{x745-att 13}	–	c78		
	2.3	testOutcome	{x745-att 12}	–	c76		
	2.4	mORTs	{x745-att 6}	–	c78		
	2.5	associatedObjects	{x745-att 3}	–	c78		
	2.6	monitoredAttributes	{dmi-att 15}	–	c78		
	2.7	proposedRepairActions	{dmi-att 19}	–	c78		
	2.8	additionalText	{dmi-att 7}	–	c78		
	2.9	additionalInformation	{dmi-att 6}	–	c76		
	2.10	notificationIdentifier	{dmi-att 16}	–	c79		
	2.11	correlatedNotifications	{dmi-att 12}	–	c80		
c77: if B.15/12a then o else –. c78: if B.15/7a then o else –. c79: if B.15/7a and B.17/2.11a then m else –. c80: if B.15/7a and B.17/2.10a then m else –.							

B.6.6 Parameters

See Table B.18.

Table B.18/M.3611 – Parameter support

Index	Parameter template label	Value of object identifier for the parameter	Constraints and values	Status	Support	Additional information
1	loopbackControlledResultsParam	{x737-par 10}	–	c81		
c81: if B.15/7a then m else –.						

B.7 Connectivity OAM access object class

B.7.1 Statement of conformance to the managed object class

See Table B.19.

Table B.19/M.3611 – Managed object class support

Index	Managed object class template label	Value of object identifier for the managed object class	Support of all mandatory features (Y/N)	Is the actual class the same as the managed object class to which conformance is claimed? (Y/N)
1	connectivityOAMAccess	{ m3611-moc 4}		

If the answer to the actual class question in the managed object class support table is no, the supplier of the implementation shall fill in the actual class support table below (see Table B.20):

Table B.20/M.3611 – Actual class support

Index	Managed object class template label for actual class	Value of object identifier for managed object class definition of actual class	Additional information
1			

B.7.2 Packages

See Table B.21.

Table B.21/M.3611 – Packages support

Index	Package template label	Value of object identifier for the package	Constraints and values	Status	Support	Additional information
1	topPackage	–	–	m		
2	packagesPackage	{dmi-pkg 16}	–	c82		
3	allomorphicPackage	{dmi-pkg 17}	–	c83		
4	connectivityOAMAccessPkg	–	–	m		
c82: if B.21/3a then m else –.						
c83: if B.19/1b then – else m.						

B.7.3 Attributes

See Table B.22.

Table B.22/M.3611 – Attribute support

Index	Attribute template label	Value of object identifier for the attribute	Constraints and values	Set by create		Get	
				Status	Support	Status	Support
1	objectClass	{dmi-att 65}	–	–		m	
2	nameBinding	{dmi-att 63}	–	–		m	
3	packages	{dmi-att 66}	–	–		c84	
4	allomorphs	{dmi-att 50}	–	–		c85	
5	connectivityOAMAccessID	{m3611-att 7}	–	–		m	
6	accessPoint	{m3611-att 2}	–	–		m	

c84: if B.21/2a then m else –.
c85: if B.21/3a then m else –.

Table B.22/M.3611 – Attribute support (concluded)

Index	Replace		Add		Remove		Set to default		Additional information
	Status	Support	Status	Support	Status	Support	Status	Support	
1	x		–		–		x		
2	x		–		–		x		
3	c86		c86		c86		c86		
4	c87		c87		c87		c87		
5	x		–		–		x		
6	m		–		–		m		

c86: if B.21/2a then x else –.
c87: if B.21/3a then x else –.

B.7.4 Actions

There are no actions defined for this managed object class.

B.7.5 Notifications

There are no notifications defined for this managed object class.

B.7.6 Parameters

There are no parameters defined for this managed object class.

B.8 VP-VC OAM access object class

B.8.1 Statement of conformance to the managed object class

See Table B.23.

Table B.23/M.3611 – Managed object class support

Index	Managed object class template label	Value of object identifier for the managed object class	Support of all mandatory features (Y/N)	Is the actual class the same as the managed object class to which conformance is claimed? (Y/N)
1	vp-vcOAMAccess	{ m3611-moc 5 }		

If the answer to the actual class question in the managed object class support table is no, the supplier of the implementation shall fill in the actual class support table below (see Table B.24):

Table B.24/M.3611 – Actual class support

Index	Managed object class template label for actual class	Value of object identifier for managed object class definition of actual class	Additional information
1			

B.8.2 Packages

See Table B.25.

Table B.25/M.3611 – Packages support

Index	Package template label	Value of object identifier for the package	Constraints and values	Status	Support	Additional information
1	topPackage	–	–	m		
2	packagesPackage	{ dmi-pkg 16 }	–	c88		
3	allomorphicPackage	{ dmi-pkg 17 }	–	c89		
4	connectivityOAMAccessPkg	–	–	m		
5	vp-vcOAMAccessPkg	–	–	m		
c88: if B.25/3a then m else –.						
c89: if B.23/1b – then else m.						

B.8.3 Attributes

See Table B.26.

Table B.26/M.3611 – Attribute support

Index	Attribute template label	Value of object identifier for the attribute	Constraints and values	Set by create		Get	
				Status	Support	Status	Support
1	objectClass	{dmi-att 65}	–	–		m	
2	nameBinding	{dmi-att 63}	–	–		m	
3	packages	{dmi-att 66}	–	–		c90	
4	allomorphs	{dmi-att 50}	–	–		c91	
5	connectivityOAMAccessID	{m3611-att 7}	–	–		m	
6	accessPoint	{m3611-att 2}	–	–		m	

c90: if B.25/2a then m else –.
c91: if B.25/3a then m else –.

Table B.26/M.3611 – Attribute support (concluded)

Index	Replace		Add		Remove		Set to default		Additional information
	Status	Support	Status	Support	Status	Support	Status	Support	
1	x		–		–		x		
2	x		–		–		x		
3	c92		c92		c92		c92		
4	c93		c93		c93		c93		
5	x		–		–		x		
6	m		–		–		m		

c92: if B.25/2a then x else –.
c93: if B.25/3a then x else –.

B.8.4 Actions

There are no actions defined for this managed object class.

B.8.5 Notifications

There are no notifications defined for this managed object class.

B.8.6 Parameters

There are no parameters defined for this managed object class.

B.9 VP-VC test action performer object class

B.9.1 Statement of conformance to the managed object class

See Table B.27.

Table B.27/M.3611 – Managed object class support

Index	Managed object class template label	Value of object identifier for the managed object class	Support of all mandatory features (Y/N)	Is the actual class the same as the managed object class to which conformance is claimed? (Y/N)
1	vp-vcTestActionPerformer	{ m3611-moc 5 }		

If the answer to the actual class question in the managed object class support table is no, the supplier of the implementation shall fill in the actual class support table below (see Table B.28):

Table B.28/M.3611 – Actual class support

Index	Managed object class template label for actual class	Value of object identifier for managed object class definition of actual class	Additional information
1			

B.9.2 Packages

See Table B.29.

Table B.29/M.3611 – Packages support

Index	Package template label	Value of object identifier for the package	Constraints and values	Status	Support	Additional information
1	topPackage	–	–	m		
2	packagesPackage	{ dmi-pkg 16 }	–	c94		
3	allomorphicPackage	{ dmi-pkg 17 }	–	c95		
4	connectivityOAMAccessPkg	–	–	m		
5	vp-vcOAMAccessPkg	–	–	m		
6	vp-vcTestActionPerformerPkg	–	–	m		
7	testActionPerformerPackage	{ x745-pkg 9 }	–	m		
8	controlledTestRequestPackage	{ x745-pkg 3 }	–	m		
9	uncontrolledTestRequestPackage	{ x745-pkg 19 }		x		
10	testSuspendResumePackage	{ x745-pkg 16 }		o		
11	testTerminatePackage	{ x745-pkg 17 }		o		
12	supportedTOClassesPackage	{ x745-pkg 7 }		m		
13	supportedUncontrolledTestsPackage	{ x745-pkg 8 }		x		
c94: if B.29/3a or B.29/10a or B.29/11a then m else –.						
c95: if B.27/1b then – else m.						

B.9.3 Attributes

See Table B.30.

Table B.30/M.3611 – Attribute support

Index	Attribute template label	Value of object identifier for the attribute	Constraints and values	Set by create		Get	
				Status	Support	Status	Support
1	objectClass	{dmi-att 65}	–	–		m	
2	nameBinding	{dmi-att 63}	–	–		m	
3	packages	{dmi-att 66}	–	–		c96	
4	allomorphs	{dmi-att 50}	–	–		c97	
5	connectivityOAMAccessID	{m3611-att 7}	–	–		m	
6	accessPoint	{m3611-att 2}	–	–		m	
7	assignedTestInvctn	{m3611-att 3}	–	–		m	
8	measurementTime	{m3611-att 9}	–	–		m	
9	testActionPerformerId	{x745-att 9}	–	–		–	
10	supportedTOClasses	{x745-att 7}	–	–		m	
11	supportedUncontrolledTests	{x745-att 8}	–	–		–	
c96: if B.29/2a then m else –. c97: if B.29/3a then m else –.							

Table B.30/M.3611 – Attribute support (concluded)

Index	Replace		Add		Remove		Set to default		Additional information
	Status	Support	Status	Support	Status	Support	Status	Support	
1	x		–		–		x		
2	x		–		–		x		
3	c98		c98		c98		c98		
4	c99		c99		c99		c99		
5	x		–		–		x		
6	m		–		–		m		
7	m		–		–		m		
8	m		–		–		m		
9	–		–		–		–		
10	x		x		x		x		
11	–		–		–		–		
c98: if B.29/2a then x else –. c99: if B.29/3a then x else –.									

B.9.4 Actions

See Table B.31.

Table B.31/M.3611 – Action support

Index	Action type template label	Value of object identifier for the action type	Sub-index	Information Reply	Constraints and values	Status	Support	Additional information
1	testRequestControlledAction	{x745-act 1}	1.1	Information	–	m		
			1.2	reply	–	m		
2	testSuspendResumeAction	{x745-act 2}	2.1	Information	–	c100		
			2.2	reply	–	c100		
3	testTerminateAction	{x745-act 3}	3.1	Information	–	c101		
			3.2	reply	–	c101		
4	testRequestUncontrolledAction	{x745-act 4}	4.1	Information	–	x		
			4.2	reply	–	x		
c100: if B.29/10a then m else –.								
c101: if B.29/11a then m else –.								

B.9.5 Notifications

There are no notifications defined for this managed object.

B.9.6 Parameters

See Table B.32.

Table B.32/M.3611 – Parameter support

Index	Parameter template label	Value of object identifier for the parameter	Constraints and values	Status	Support	Additional information
1	noSuchMORT	{x745-par 7}	–	m		
2	mORTNotAvailable	{x745-par 5}	–	m		
3	mistypedTestCategoryInformation	{x745-par 4}	–	m		
4	noSuchAssociatedObject	{x745-par 6}	–	o		
5	associatedObjectNotAvailable	{x745-par 1}	–	o		
6	independentTestInvocationError	{x745-par 2}	–	m		
7	relatedTOError	{x745-par 10}	–	m		
8	invalidTestOperation	{x745-par 3}	–	c102		
9	noSuchTestInvocationId	{x745-par 8}	–	c102		
10	noSuchTestSessionId	{x745-par 9}	–	c102		
11	testSuspendResumeError	{x745-par 11}	–	c103		
12	testTerminateError	{x745-par 12}	–	c104		
c102: if B.31/2a or B.31/3a then m else –.						
c103: if B.31/2a then m else –.						
c104: if B.31/3a then m else –.						

B.10 VP-VC test signal source object class

B.10.1 Statement of conformance to the managed object class

See Table B.33.

Table B.33/M.3611 – Managed object class support

Index	Managed object class template label	Value of object identifier for the managed object class	Support of all mandatory features (Y/N)	Is the actual class the same as the managed object class to which conformance is claimed? (Y/N)
1	vp-vcTestActionPerformer	{ m3611-moc 5 }		

If the answer to the actual class question in the managed object class support table is no, the supplier of the implementation shall fill in the actual class support table below (see Table B.34):

Table B.34/M.3611 – Actual class support

Index	Managed object class template label for actual class	Value of object identifier for managed object class definition of actual class	Additional information
1			

B.10.2 Packages

See Table B.35.

Table B.35/M.3611 – Packages support

Index	Package template label	Value of object identifier for the package	Constraints and values	Status	Support	Additional information
1	topPackage	–	–	m		
2	packagesPackage	{ dmi-pkg 16 }	–	c105		
3	allomorphicPackage	{ dmi-pkg 17 }	–	c106		
4	connectivityOAMAccessPkg	–	–	m		
5	vp-vcOAMAccessPkg	–	–	m		
6	vp-vcTestSignalSourcePkg	–	–	m		
c105: if B.35/3a then m else –. c106: if B.33/1b then – else m.						

B.10.3 Attributes

See Table B.36.

Table B.36/M.3611 – Attribute support

Index	Attribute template label	Value of object identifier for the attribute	Constraints and values	Set by create		Get	
				Status	Support	Status	Support
1	objectClass	{dmi-att 65}	–	–		m	
2	nameBinding	{dmi-att 63}	–	–		m	
3	packages	{dmi-att 66}	–	–		c107	
4	allomorphs	{dmi-att 50}	–	–		c108	
5	connectivityOAMAccessID	{m3611-att 7}	–	–		m	
6	accessPoint	{m3611-att 2}	–	–		m	

c107: if B.35/2a then m else –.
c108: if B.35/3a then m else –.

Table B.36 – Attribute support (concluded)

Index	Replace		Add		Remove		Set to default		Additional information
	Status	Support	Status	Support	Status	Support	Status	Support	
1	x		–		–		x		
2	x		–		–		x		
3	c109		c109		c109		c109		
4	c110		c110		c110		c110		
5	x		–		–		x		
6	m		–		–		m		

c109: if B.35/2a then x else –.
c110: if B.35/3a then x else –.

B.10.4 Actions

There are no actions defined for this managed object class.

B.10.5 Notifications

There are no notifications defined for this managed object class.

B.10.6 Parameters

There are no parameters defined for this managed object class.

ITU-T RECOMMENDATIONS SERIES

Series A	Organization of the work of the ITU-T
Series B	Means of expression: definitions, symbols, classification
Series C	General telecommunication statistics
Series D	General tariff principles
Series E	Overall network operation, telephone service, service operation and human factors
Series F	Non-telephone telecommunication services
Series G	Transmission systems and media, digital systems and networks
Series H	Audiovisual and multimedia systems
Series I	Integrated services digital network
Series J	Transmission of television, sound programme and other multimedia signals
Series K	Protection against interference
Series L	Construction, installation and protection of cables and other elements of outside plant
Series M	TMN and network maintenance: international transmission systems, telephone circuits, telegraphy, facsimile and leased circuits
Series N	Maintenance: international sound programme and television transmission circuits
Series O	Specifications of measuring equipment
Series P	Telephone transmission quality, telephone installations, local line networks
Series Q	Switching and signalling
Series R	Telegraph transmission
Series S	Telegraph services terminal equipment
Series T	Terminals for telematic services
Series U	Telegraph switching
Series V	Data communication over the telephone network
Series X	Data networks and open system communication
Series Z	Programming languages