

International Telecommunication Union

ITU-T

TELECOMMUNICATION
STANDARDIZATION SECTOR
OF ITU

P.64

(11/2007)

SERIES P: TELEPHONE TRANSMISSION QUALITY,
TELEPHONE INSTALLATIONS, LOCAL LINE
NETWORKS

Objective electro-acoustical measurements

**Determination of sensitivity/frequency
characteristics of local telephone systems**

Recommendation ITU-T P.64



ITU-T P-SERIES RECOMMENDATIONS

TELEPHONE TRANSMISSION QUALITY, TELEPHONE INSTALLATIONS, LOCAL LINE NETWORKS

Vocabulary and effects of transmission parameters on customer opinion of transmission quality	Series	P.10
Subscribers' lines and sets	Series	P.30
		P.300
Transmission standards	Series	P.40
Objective measuring apparatus	Series	P.50
		P.500
Objective electro-acoustical measurements	Series	P.60
Measurements related to speech loudness	Series	P.70
Methods for objective and subjective assessment of quality	Series	P.80
		P.800
Audiovisual quality in multimedia services	Series	P.900
Transmission performance and QoS aspects of IP end-points	Series	P.1000

For further details, please refer to the list of ITU-T Recommendations.

Recommendation ITU-T P.64

Determination of sensitivity/frequency characteristics of local telephone systems

Summary

Recommendation ITU-T P.64 is mainly concerned with electro-acoustical measurements required for supplying sensitivity/frequency characteristics suitable for use in calculating loudness ratings, or estimating other subjectivity-determined quantities. For this purpose, measurements under real conditions must form the basis. Artificial mouths and artificial ears must be used with due regard to obtaining good agreement between these measurements and those from real mouth and ear determinations. Measurements under real conditions are complicated, time-consuming and not reproducible with great precision.

This Recommendation describes measurement methods using recommended forms of artificial mouths and artificial ears (see Recommendations ITU-T P.51 and P.57).

This Recommendation applies mainly to local telephone systems (LTSs) with handset telephones; however, the principles also apply to other types of telephones.

Annexes D and E define handset positions to be used with HATS according to P.58 and P.57 type 3.2, 3.3 and 3.4 artificial ears. Allowance is given to placing the handset in a way which best represents its intended use.

Annex F describes correspondence between measurements using the loudness rating guard-ring position (LRGP) and the head and torso simulator (HATS) position.

Source

Recommendation ITU-T P.64 was approved on 13 November 2007 by ITU-T Study Group 12 (2005-2008) under Recommendation ITU-T A.8 procedure.

FOREWORD

The International Telecommunication Union (ITU) is the United Nations specialized agency in the field of telecommunications, information and communication technologies (ICTs). The ITU Telecommunication Standardization Sector (ITU-T) is a permanent organ of ITU. ITU-T is responsible for studying technical, operating and tariff questions and issuing Recommendations on them with a view to standardizing telecommunications on a worldwide basis.

The World Telecommunication Standardization Assembly (WTSA), which meets every four years, establishes the topics for study by the ITU-T study groups which, in turn, produce Recommendations on these topics.

The approval of ITU-T Recommendations is covered by the procedure laid down in WTSA Resolution 1.

In some areas of information technology which fall within ITU-T's purview, the necessary standards are prepared on a collaborative basis with ISO and IEC.

NOTE

In this Recommendation, the expression "Administration" is used for conciseness to indicate both a telecommunication administration and a recognized operating agency.

Compliance with this Recommendation is voluntary. However, the Recommendation may contain certain mandatory provisions (to ensure e.g. interoperability or applicability) and compliance with the Recommendation is achieved when all of these mandatory provisions are met. The words "shall" or some other obligatory language such as "must" and the negative equivalents are used to express requirements. The use of such words does not suggest that compliance with the Recommendation is required of any party.

INTELLECTUAL PROPERTY RIGHTS

ITU draws attention to the possibility that the practice or implementation of this Recommendation may involve the use of a claimed Intellectual Property Right. ITU takes no position concerning the evidence, validity or applicability of claimed Intellectual Property Rights, whether asserted by ITU members or others outside of the Recommendation development process.

As of the date of approval of this Recommendation, ITU had not received notice of intellectual property, protected by patents, which may be required to implement this Recommendation. However, implementers are cautioned that this may not represent the latest information and are therefore strongly urged to consult the TSB patent database at <http://www.itu.int/ITU-T/ipr/>.

© ITU 2008

All rights reserved. No part of this publication may be reproduced, by any means whatsoever, without the prior written permission of ITU.

CONTENTS

		Page
1	Scope	1
2	References	1
3	Abbreviations	2
4	Sending sensitivities of the LTS.....	2
5	Receiving sensitivities of the LTS.....	3
6	Artificial mouth and voice.....	4
7	Artificial ear	4
8	Definition of sending sensitivity of an LTS	4
9	Definition of receiving sensitivity of an LTS.....	5
10	Definitions of talker and listener sidetone sensitivities of an LTS.....	5
11	Methods for determining S_{mJ} , S_{Je} , S_{meST} , S_{RNST} and Δ_{SM}	6
	Annex A – Definitions of mouth reference point and ear reference point	11
	Annex B – The application of complex terminating impedances when measuring SLR and RLR	12
	B.1 Complex impedance terminations.....	12
	B.2 Impedance converter	12
	B.3 Differences when measuring a telephone set with a complex impedance using 600 ohm terminations	15
	Annex C – Definition of the speaking position for measuring loudness ratings of handset telephones.....	18
	C.1 Geometry defining a speaking position.....	18
	C.2 Geometry defining a change in speaking position	19
	C.3 Simplification through the use of the position of the ear reference point.....	19
	C.4 Vector representation of the reference points	19
	Annex D – Definition of handset positions for measuring loudness ratings and frequency responses using the P.57 type 3.4 artificial ear on HATS.....	21
	D.1 General	21
	D.2 Definition of the standard handset position.....	21
	D.3 Definition of the flat handset position.....	22
	D.4 Definition of the alternative handset position for measuring loudness ratings and frequency responses using the P.57 type 3.4 artificial ear on HATS	22
	Annex E – Definition of handset positions for measuring loudness ratings and frequency responses using the P.57 types 3.2 and 3.3 artificial ear on HATS.....	24
	E.1 Definition of standard handset position for measuring loudness ratings and frequency responses using the P.57 types 3.2 and 3.3 artificial ear on HATS	24

	Page
E.2 Definition of the alternative handset position for measuring loudness ratings and frequency responses using the P.57 type 3.3 artificial ear on HATS	25
Annex F – Correspondence between measurements using the LRGP and the HATS position	27
Bibliography	28

Recommendation ITU-T P.64

Determination of sensitivity/frequency characteristics of local telephone systems

1 Scope

The sending, receiving or sidetone sensitivity/frequency characteristic of a local telephone system (LTS) is usually measured directly.

NOTE 1 – The sending, receiving or sidetone sensitivity/frequency characteristic can also be calculated provided that the relevant information of the telephone line and feeding bridge is known. Some of the information required for sidetone is outside the scope of existing Recommendations.

NOTE 2 – The same principles also apply to the measurement of microphones and earphones.

Since electro-acoustical measurements of the type being considered may be required for different purposes, it is important to distinguish the following:

- a) supplying the designer of a transducer with information concerning the success he has achieved in aiming at a given sensitivity/frequency response;
- b) checking that the manufactured product meets the specified requirements;
- c) supplying sensitivity/frequency characteristics suitable for use in calculating loudness ratings or estimating other subjectivity-determined quantities.

This Recommendation is mainly concerned with c), but the principle is also applicable to a) and b). For these purposes, especially for c), measurements under real conditions must form the basis. Artificial mouths and artificial ears must be used with due regard to obtaining good agreement between these measurements and those from real mouth and ear determinations. Measurements under real conditions are complicated, time-consuming and not reproducible with great precision. This Recommendation describes measurement methods using recommended forms of artificial mouths and artificial ears (see [ITU-T P.51] and [ITU-T P.57]).

This Recommendation applies mainly to LTSs with handset telephones. However, the principles also apply to other types of telephones. Specific considerations for headsets are described in [ITU-T P.380] and, for loudspeaker telephones, [ITU-T P.340].

See [ITU-T P.76] for general principles concerning the determination of loudness ratings.

2 References

The following ITU-T Recommendations and other references contain provisions which, through reference in this text, constitute provisions of this Recommendation. At the time of publication, the editions indicated were valid. All Recommendations and other references are subject to revision; users of this Recommendation are therefore encouraged to investigate the possibility of applying the most recent edition of the Recommendations and other references listed below. A list of the currently valid ITU-T Recommendations is regularly published. The reference to a document within this Recommendation does not give it, as a stand-alone document, the status of a Recommendation.

[ITU-T G.111] Recommendation ITU-T G.111 (1993), *Loudness ratings (LRs) in an international connection*.

[ITU-T P.10] Recommendation ITU-T P.10/G.100 (2006), *Vocabulary for performance and quality of service*.

[ITU-T P.50] Recommendation ITU-T P.50 (1999), *Artificial voices*.

[ITU-T P.51] Recommendation ITU-T P.51 (1996), *Artificial mouth*.

[ITU-T P.57]	Recommendation ITU-T P.57 (2005), <i>Artificial ears</i> .
[ITU-T P.58]	Recommendation ITU-T P.58 (1996), <i>Head and torso simulator for telephonometry</i> .
[ITU-T P.76]	Recommendation ITU-T P.76 (1988), <i>Determination of loudness ratings; fundamental principles</i> .
[ITU-T P.78]	Recommendation ITU-T P.78 (1996), <i>Subjective testing method for determination of loudness ratings in accordance with Recommendation P.76</i> .
[ITU-T P.79]	Recommendation ITU-T P.79 (2007), <i>Calculation of loudness ratings for telephone sets</i> .
[ITU-T P.340]	Recommendation ITU-T P.340 (2000), <i>Transmission characteristics and speech quality parameters of hands-free terminals</i> .
[ITU-T P.380]	Recommendation ITU-T P.380 (2003), <i>Electro-acoustic measurements on headsets</i> .
[ITU-T Q.552]	Recommendation ITU-T Q.552 (2001), <i>Transmission characteristics at 2-wire analogue interfaces of digital exchanges</i> .

3 Abbreviations

This Recommendation uses the following abbreviations:

DRP	Drum Reference Point
ECRP	EarCap Reference Point
EEP	Ear canal Entrance Point
ERP	Ear Reference Point
FFT	Fast Fourier Transform
HATS	Head and Torso Simulator
LRGP	Loudness Rating Guard-ring Position
LSTR	Listener SideTone Rating
LTS	Local Telephone System
MRP	Mouth Reference Point
RLR	Receive Loudness Rating
SLR	Send Loudness Rating
STMR	SideTone Masking Rating

4 Sending sensitivities of the LTS

For the present purposes, the sending sensitivity of a local telephone system is specified in terms of the free-field sound pressure at a reference point in front of the mouth¹, and the electrical output from the local telephone system or the microphone as the case may be. The input sound pressure cannot be measured simultaneously with the electrical output and therefore the measurement must be made in an indirect manner. The sound pressure at the reference point is measured in the absence of the handset and, with the artificial mouth source unchanged, the handset is placed in the defined

¹ The mouth reference point used in this Recommendation is defined in Annex A.

position in front of the mouth and the output measured. When a human mouth and voice are used, the source cannot be relied upon to maintain its output constant between the measurement of free-field sound pressure and that of the electrical output from the microphone. Artificial mouths suffer from imperfect representation of the source impedance and field distribution that applies to real mouths.

In addition to providing the proper source conditions, it is necessary to ensure that the mouthpiece is located for every design of telephone handset at the position that would be used in the real situation. This can be achieved by locating the mouthpiece properly with respect to an ear reference point; this ensures that longer handsets are measured with a greater mouth-to-microphone distance than is the case for shorter handsets. The success of using a given handset measuring position for measurement of sensitivity/frequency characteristics can be judged only by making comparisons for handsets of different lengths, between real conversation test results using the artificial mouth and real mouths under suitably controlled measuring conditions. For this Recommendation, the telephone handset shall be located as defined in Annex C. The handset positions to be used with HATS according to [ITU-T P.58] and type 3.3 and 3.4 pinna simulators are defined in Annexes D and E.

Special problems are encountered when making measurements with real mouths and real voices, even under controlled talking conditions. Under such circumstances, the sound pressure cannot be measured directly at the required mouth reference point and therefore it has to be measured at some other point and referred indirectly to the mouth reference point. Some previous determinations have made use of a measuring microphone 1 metre from the mouth but this requires anechoic surroundings and is affected by obstruction from the handset under test. Other methods have been also tried and none seem satisfactory so far.

5 Receiving sensitivities of the LTS

The type 1 artificial ear (see [ITU-T P.57] to be specified in [b-IEC 60318-1]) provides means for precise measurements of the receiving sensitivities of the LTS. However, the sound pressures measured with it do not always agree well with those existing at the ear reference point in real ears under the test conditions used when subjective determinations of loudness ratings are being made. This can be attributed partly to the presence of appreciable acoustical leakage (L_E) between the earphone and the real ear (such leakage is not represented in available recommended forms of the artificial ear) and partly to an increase in enclosed volume between the forms of earphones and the forms of real ears. Therefore, to use the results of measurements made according to this Recommendation, if a type 1 [b-IEC 60318-1] artificial ear is used, it is necessary to make a correction (see clause 9 below).

[ITU-T P.57] describes the different existing ear simulators and their relevant domain of applicability.

In the case of the type 1 artificial ear, proper values of L_E should be used since this device does not include acoustic leak.

In the case of other devices, built-in or naturally-induced leaks exist. Consequently, for receiving loudness rating calculation according to [ITU-T P.79], the leakage term L_E shall be set to zero.

For these devices as well, the sound pressure is measured at the drum reference point (DRP). The correction functions given in [ITU-T P.57] for the different ears shall be used for converting data to the ear reference point (ERP).

6 Artificial mouth and voice

The following properties are required:

- a) The distribution in sound pressure around the orifice must be a good approximation to that around a human mouth.
- b) The acoustical impedance looking into the mouth must simulate that for human mouths, so that the pressure increase caused by the obstruction effect of telephone microphones will be representative.
- c) It must be possible to establish definite sound pressures at the mouth reference point as a function of frequency. A convenient feature to embody in a practical artificial mouth is the linearity, over a suitable range of sound pressures, of the ratio of sound pressure at the mouth reference point to the voltage input to the artificial mouth. The ratio must be independent of frequency at least over the range 200 to 4000 Hz but preferably 100 to 8000 Hz.

For the present purposes, the mouth reference point (MRP) is defined by the point on the axis of the artificial mouth located 25 mm in front of the equivalent lip position (see Annex A).

[ITU-T P.51] and [ITU-T P.58] define the requirements for artificial mouths.

7 Artificial ear

The following properties are required:

- a) The acoustical impedance presented to telephone earphones must simulate that presented by real ears under practical conditions of use of telephone handsets.
- b) The sensitivity of the artificial ear is defined as the pressure sensitivity of the ratio between the output of the artificial ear and the corresponding sound pressure level at the ERP measured under open ear conditions, see [ITU-T P.57].

For a human ear, the ear reference point (ERP) is defined in Annex A. The corresponding point when the earcap is fitted to an artificial ear will usually differ from the place at which the sound pressure is measured and for this and other reasons, certain corrections are necessary when the results are used for calculating loudness ratings (see clause 5 above).

8 Definition of sending sensitivity of an LTS

The sending sensitivity of an LTS depends upon the location of the handset relative to the equivalent lip position of the artificial mouth. For the present purposes, the speaking position defined in Annex C shall be used.

Annex D defines the handset positions to be used with HATS according to [ITU-T P.58] and [ITU-T P.57] type 3.4 pinna simulator. Pressure forces to be used in conjunction with type 3.4 artificial ear are typically in the range of 2 N to 13 N. 2 N corresponds to a loosely held handset. 13 N corresponds to a situation when the handset is pressed tight against the ear.

Similarly Annex E defines the handset positions to be used with HATS according to [ITU-T P.58] and [ITU-T P.57] ear simulators type 3.2 and 3.3. With the type 3.2 ear simulator, having a well-defined contact rim, the handset is applied towards the nominal ERP position.

With the type 3.3 anatomically shaped pinna simulator, the default position is the nominal ERP position. This position corresponds to a loosely held handset (high leak). Application forces in the range of 10 to 20 N may be applied to decrease the acoustic leak.

NOTE – The results measured with Annex D and E set-ups should always clearly indicate the test conditions.

Usually, the sending sensitivity is a function of frequency.

The sending sensitivity of a local telephone system at a specified frequency or in a narrow frequency band is expressed as follows:

$$S_{mJ} = 20 \log_{10} \frac{V_J}{P_m} \text{ dB rel 1V/Pa}$$

where V_J is the voltage across a 600 ohm termination and p_m is the sound pressure at the mouth reference point. Note that p_m must be measured in the absence of the "unknown" handset of the test item.

Administrations who wish to use complex impedance termination for the measurement are referred to the method given in Annex B. The use of complex impedance terminations may change the SLR and RLR values slightly, in comparison to the values using 600 ohm termination. Furthermore, the break points for sending and receiving local telephone systems could change. The effect will be under study.

9 Definition of receiving sensitivity of an LTS

Usually, the receiving sensitivity is a function of frequency. The receiving sensitivity of a local telephone system at a specified frequency or in a narrow frequency band, as measured directly with an artificial ear complying with [ITU-T P.57], is expressed as follows:

$$S_{Je} = 20 \log_{10} \frac{P_e}{\frac{1}{2} E_J} \text{ dB rel 1Pa/V}$$

where p_e is the sound pressure at the ERP and $\frac{1}{2} E_J$ is half the emf in the 600 ohm source. See also clause 8 for complex impedance termination.

NOTE – The receiving sensitivity suitable for use in calculation of loudness is given by:

$$S_{Je} = S_{Je} - L_E$$

where L_E is a correction explained above in clause 5, and S_{JE} is the receiving sensitivity determined using a large number of real ears. Note that if type 3.2, 3.3 or 3.4 artificial ears are used for receiving loudness rating calculations according to [ITU-T P.79], the real ear loss correction L_E should be set to zero.

Further information on this topic is given in [ITU-T P.57] and [ITU-T P.79].

10 Definitions of talker and listener sidetone sensitivities of an LTS

The talker sidetone sensitivity of an LTS is a function of the sending and receiving sensitivities of the telephone set, but also depends on a number of factors including the local subscriber's line conditions, the effective terminating impedance at the local exchange and the sidetone balance circuit within the telephone set.

The sidetone sensitivity, as measured from an artificial mouth to the telephone earphone, is expressed as:

$$S_{meST} = 20 \log_{10} \left(\frac{P_e}{P_m} \right) \text{ dB}$$

where p_m is defined in clause 8, and p_e is the sound pressure developed at the ERP with the handset in the loudness rating guard-ring position (LRGP).

The listener sidetone sensitivity as measured in a diffuse room noise field is expressed as:

$$S_{RNST} = 20 \log_{10} \left(\frac{P_e}{P_{RN}} \right) \text{ dB}$$

where p_e is the sound pressure developed at the ERP with the handset held at LRGP in front of an unenergized artificial mouth, for a diffuse room noise sound pressure p_{RN} measured at the MRP, but in the absence of all obstacles (e.g., test head, handset, etc.).

11 Methods for determining S_{mJ} , S_{Je} , S_{meST} , S_{RNST} and Δ_{SM}

When the sending, receiving and sidetone sensitivities of an actual local telephone system are required, the measurements according to the definitions given in clauses 8, 9 and 10 above can be made as illustrated in Figures 1, 2, 3, 4 and 5. These methods have been used by many laboratories successfully.

When using fast fourier transform (FFT) techniques for measuring the characteristics of non-linear LTS, the measurement principle used, i.e., ratio of r.m.s. variables, or cross-spectrum (coherent) method, should be specified.

More detail may be found in Section 3 of the [b-ITU-T Handbook].

Figure 1 shows the method of setting up the artificial mouth so that the sound pressure p_m at the mouth reference point is known at each test frequency or frequency band. It is recommended to provide equalization in the artificial mouth drive circuit to maintain the free-field sound pressure constant at the MRP to within ± 1 dB over the frequency range 100 to 8000 Hz. In no case should the deviation exceed ± 2 dB over the frequency range 200 to 4000 Hz and $+2/-5$ dB over the frequency range 100 to 8000 Hz. It is recommended that any deviations from the desired sound pressure level be taken into account when determining the sending or sidetone sensitivity of a local telephone system. This is particularly true if the deviation exceeds ± 1 dB.

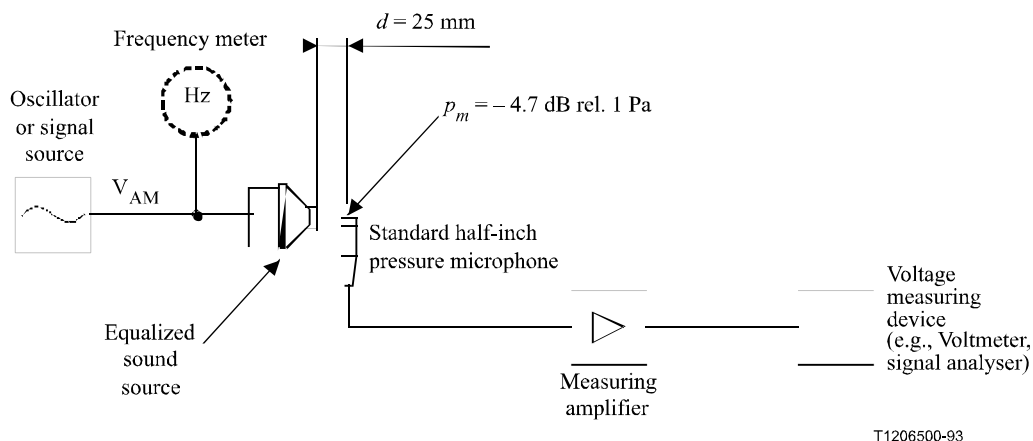

Figure 1 – Measurement of acoustic pressure p_m at the mouth reference point 25 mm from the artificial lip plane of the sound source

For any test signal, p_m of -4.7 dBPa is recommended (see clause 3.6.3 of [b-ITU-T Handbook]).

When sine waves are used as the test signal, the test frequency points should be those of ISO 1/3 octave frequencies from 200 Hz to 4000 Hz for the purpose of calculating sending and receiving loudness ratings. However, for the purpose of frequency response measurement, the interval of 1/3 octave only gives a rough estimation of the system under test. In this case, more

frequency points are recommended. It is considered that the interval should be 1/12 octave or smaller. Also when various noise signals, or artificial voice such as [ITU-T P.50], are used as test signal, the 1/3 octave filters will be used for both test signal and the output from the system under test for the purpose of calculating loudness rating. If a more accurate frequency response curve is desired, the use of narrower bandwidth filters is recommended.

Figure 2 shows the measurement of output V_J from the local telephone system when the handset is placed at the appropriate position in front of the artificial mouth and the artificial mouth is energized in the same manner as when the sound pressure p_m was set up in the absence of the handset under test (see Figure 1).

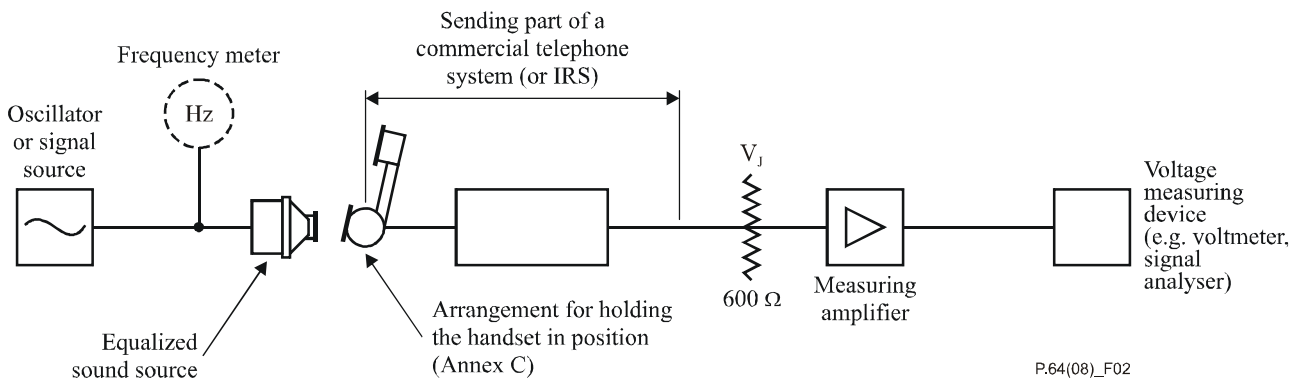

Figure 2 – Voltage V_J measured across the terminals of a 600 ohm pure resistance connected to the output of a sending system under test

Figure 3 shows the measurement of the sound pressure p_e in the artificial ear when the local telephone system is connected to a 600-ohm source of internal emf E_J . Note that the definition of S_{J_e} is in terms of $1/2 E_J$ and not the potential difference across the input terminals of the local telephone system; this potential difference will, of course, differ from $1/2 E_J$ if the input impedance of the local telephone system is not 600 ohms. Care must be taken to ensure that there is no coupling loss (acoustic leakage) between the earpiece of the receiving system under test and the artificial ear. Usually $E_J = -12$ dBV is recommended.

NOTE 1 – Some receiving systems incorporate electronic circuits to provide special features, for example, compression to limit the level of the received sound signal. Particular care must be exercised during the measurement of such systems to ensure that the resulting sensitivity is correct and relevant. In some cases, it may be necessary to determine the receiving sensitivity over a range of input levels.

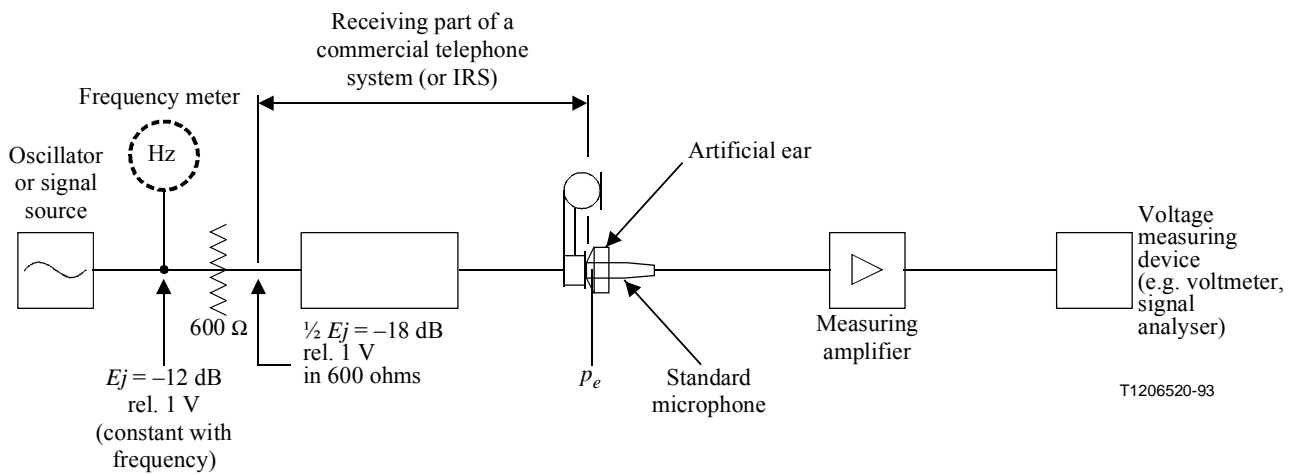

Figure 3 – Measurement of acoustic pressure p_e at the ERP developed by the receiving system under test

Figure 4 shows the measurement of sidetone sensitivity. The resulting value of S_{meST} is highly dependent on the impedance connected to the telephone set terminals and therefore, under short line conditions, on the exchange termination. As this impedance often deviates considerably from 600 ohms, particularly when there is a complete connection present, 600 ohms is given only as an example.

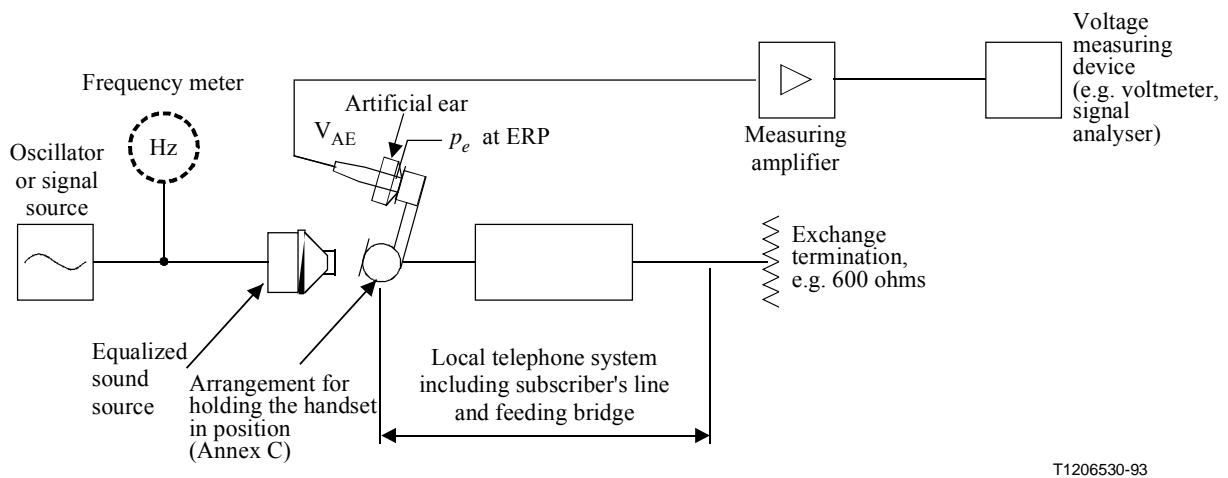
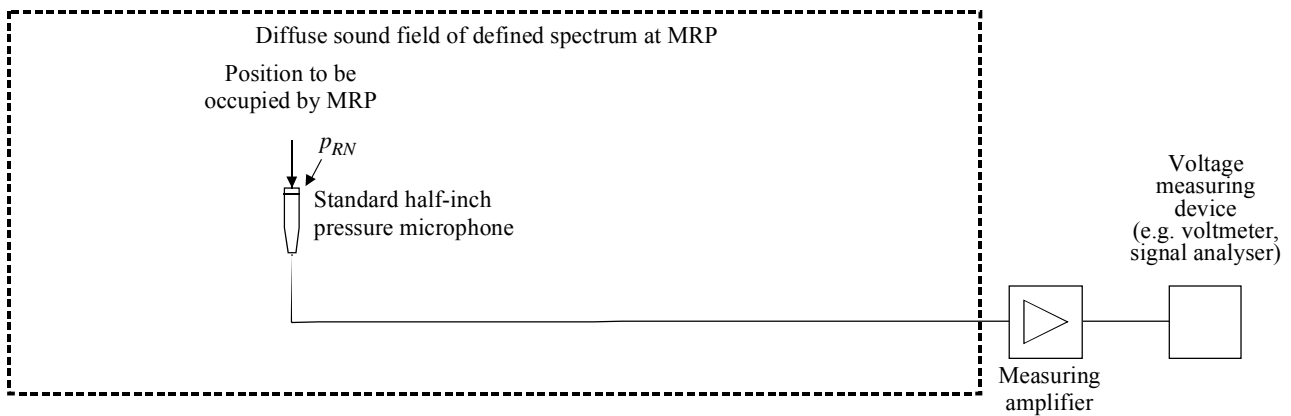
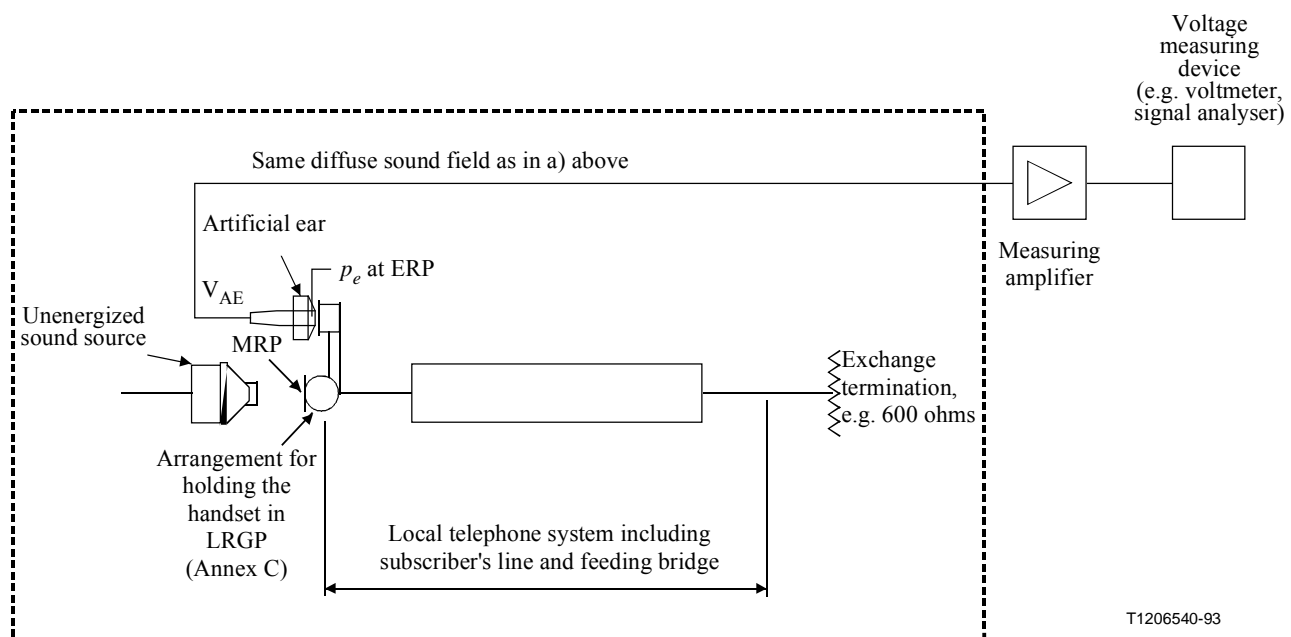

Figure 4 – Measurement of the sidetone sensitivity of a commercial telephone system by determination of the sound pressure p_e developed at the ERP for a given sound signal at the MRP

The determination of the room noise sidetone sensitivity S_{RNST} is illustrated in Figure 5. For this measurement, sine wave signals are unsuitable and it is necessary to make use of continuous spectrum sound having, for example, a Hoth or pink noise spectrum. First, the magnitude of the diffuse field p_{RN} is determined, as shown in Figure 5 a), at the absence of the test head and all other obstacles. The calibration of the diffuse sound pressure p_{RN} may be carried out using the half-inch pressure microphone at each test frequency band to determine p_{RN} as a function of frequency. The sound pressure at the artificial ear is then measured as shown in Figure 5 b), with the artificial mouth in due position but unenergized.



a) Measurement of diffuse sound field at MRP



b) Measurement of p_e at the artificial ear due to diffuse sound field, p_{RN} heard via the telephone sidetone path

Figure 5 – Determination of room noise sidetone sensitivity

The room noise sidetone sensitivity S_{RNST} can be a function of room noise level, particularly for sets having carbon microphones. It will normally be appropriate to use a diffuse sound pressure p_{RN} that is much lower than the value of -4.7 dBPa used for p_m in determining STMR and SLR. Typical values for p_{RN} would lie in the range 40-65 dB SPL (-54 to -29 dBPa, A weighted). The actual level and type of noise should always be stated in quoting test results.

Using the above method, the sound pressure developed at the artificial ear usually is very low in certain frequency bands which can cause accuracy problems in most measurements. An alternative way to determine S_{RNST} is to measure the sending sensitivity S_{mJ} using an artificial mouth and one of the methods in clause 3.6.3 of [b-ITU-T Handbook], using a continuous spectrum signal and then to measure the room noise sending sensitivity $S_{mJ/RN}$ using a diffuse field method such as described for room noise sidetone sensitivity above (a detailed description of the method is given in [b-ITU-T Handbook]).

The definition of Δ_{SM} is:

$$\Delta_{SM} = S_{mJ/RN} - S_{mJ}$$

where S_{mJ} is the real voice sensitivity.

However, for all practical purposes, when using the artificial mouth, we may consider that Δ_{SM} is equal to Δ_{Sm} :

$$\Delta_{Sm} = S_{mJ/RN} - S_{mJ}$$

so that S_{RNST} can be determined by the approximation:

$$S_{RNST} \cong S_{meST} + \Delta_{Sm}$$

NOTE 2 – For an explanation of how Δ_{SM} may be used in the determination of listener sidetone rating (LSTR) from sidetone masking rating (STM), see [ITU-T P.76], [ITU-T P.79] and [ITU-T G.111].

NOTE 3 – The room noise sending sensitivity $S_{mJ/RN}$, and hence Δ_{Sm} also is often dependent on the room noise level of p_{RN} . It is recommended that the level of p_{RN} should also be mentioned together with Δ_{Sm} . Typical value of p_{RN} should also lie within 40-65 dB SPL (see clause 3.3.17 of [b-ITU-T Handbook]).

NOTE 4 – Both S_{mJ} and $S_{mJ/RN}$ should use the same techniques, e.g., wideband signals measured in 1/3 octave bands.

NOTE 5 – The approximate formulae for S_{RNST} can be deemed to be equal for linear systems.

NOTE 6 – When a type 3.2 artificial ear is used for the measurement of LSTR, room noise will reach the measuring microphone through the leak slot of the artificial ear. The effect is under study. In this case, for the time being, the use of Δ_{Sm} for determining S_{RNST} is recommended.

Annex A

Definitions of mouth reference point and ear reference point

(This annex forms an integral part of this Recommendation)

The definitions of mouth reference point (MRP) and ear reference point (ERP) are illustrated in Figure A.1.

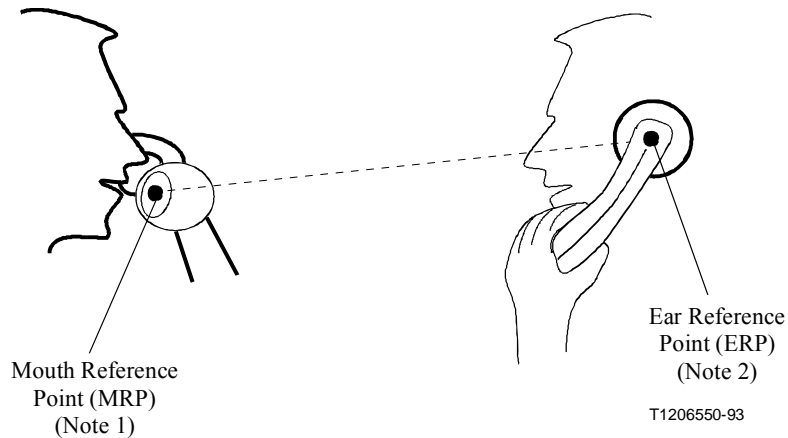

NOTE 1 – The mouth reference point is located at a distance of 25 mm in front of the lips on the horizontal axis through the center of the opening of the mouth. It is defined in the absence of any obstruction.

NOTE 2 – For a supra-aural earcap, the ERP would approximate to the position taken up by the centre of the earcap reference plane.

NOTE 3 – The ERP should not be confused with the EarCap Reference Point (ECRP) which is a point in the earphone reference plane used as a handset reference parameter (see Recommendation P.10).

Figure A.1 – Definitions of mouth and ear reference points

Annex B

The application of complex terminating impedances when measuring SLR and RLR

(This annex forms an integral part of this Recommendation)

B.1 Complex impedance terminations

Administrations have found that the use of a complex impedance $Z(f)$ as the nominal (2-wire) terminating impedance instead of 600 ohms improves echo and sidetone performance in the network.

The nominal impedance is implemented in such a way that it gives a reasonable approximation of the characteristic impedances of the unloaded subscriber cables most commonly used by the administration. In this way, the impedance variations with cable lengths are very much diminished. In particular, it is a great advantage if an equipment connected to the 2-wire interface of a digital exchange (directly or via a cable) is designed to have an input impedance closely resembling this nominal impedance Z .

In general, Z is defined as a resistance R_s in series with a parallel combination of a resistance R_p and a capacitance C_p . Because the subscriber networks may differ between administrations, the values of R_s , R_p and C_p also differ somewhat between administrations (see, for instance, [ITU-T Q.552] for examples).

When a particular complex nominal impedance Z is specified by an administration, all 2-wire equipment measurements are usually made with that impedance, and not with 600 ohms. This rule also applies for telephone sets.

In transmission planning, the SLR and RLR of a telephone set are considered in conjunction with the relative levels at the point where the set is connected. For a certain relative level, the voltage of the (sinusoidal) 1020 Hz reference signal depends on the nominal impedance. Thus, to relate the send and receive sensitivities to the relative level, a correction factor K must be applied when the nominal impedance no longer is 600 ohms.

$$K = 10 \log_{10} \left| \frac{Z(1020 \text{ Hz})}{600} \right| \text{ dB} \quad |Z| \text{ in ohms}$$

K is added to the send sensitivity and subtracted from the receive sensitivity.

The correction factor K can be included in the measuring set-up by use of an impedance converter which is specified in clause B.2 (in this case, the factor K need not be included in the calculations. Another advantage is that normal 600 ohm interfaces can be used in the rest of the measuring set-up).

B.2 Impedance converter

This device converts the defined 600 Ω -points on the device under test to the appropriate nominal impedance Z_N and takes account of the corresponding correction factor. A further advantage is that all measurements are done with the specified level taking into account all influences even in non-linear systems. Thus, the value of the loudness rating is indicated correctly.

For measuring sending (SLR) and receiving (RLR), this converter must be switched in the direction of the amplification and correction factor. For measuring sidetone, no converter is needed because network-specific terminations are used anyway.

Figures B.1 and B.2 show how the device is inserted in Figures 2 and 3, respectively.

Specification of the impedance converters, the block diagram of which are shown in Figure B.3:

- open-loop gain at the sending end: $(6 - K)$ dB \pm 0.1 dB;
- open-loop gain at the receiving end: $(6 + K)$ dB \pm 0.1 dB;

where:

$$K = 10 \log_{10} \left| \frac{Z_N(1020 \text{ Hz})}{600} \right|$$

- return loss against the nominal value (600Ω or Z_N): $a_R \geq 40$ dB;
- dynamic range: At input levels from -70 dB (775 mV) up to $+15$ dB (775 mV), deviation of linearity is less than 0.1 dB;
- unweighted signal-to-noise ratio > 75 dB at 600Ω ; frequency range: 20 Hz-20 kHz;
- common mode rejection: > 50 dB.

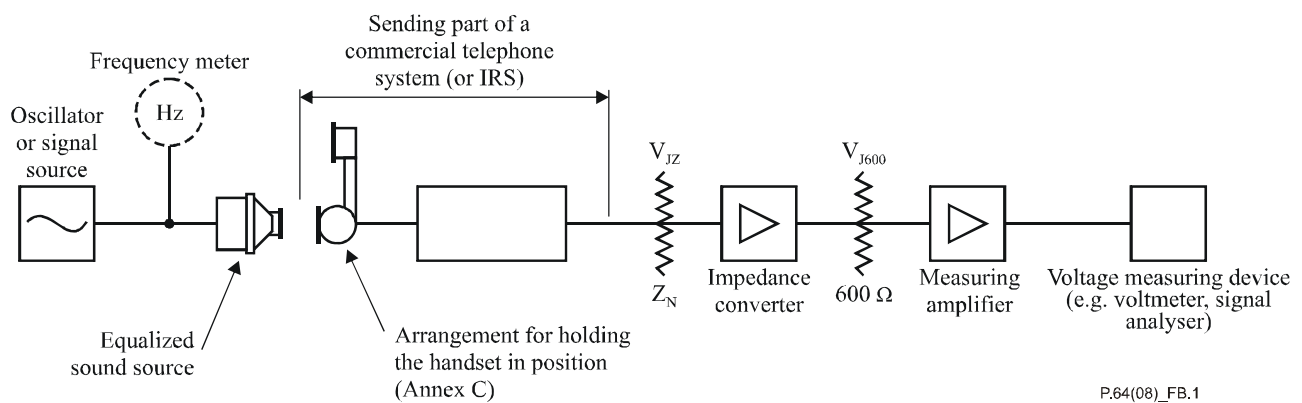
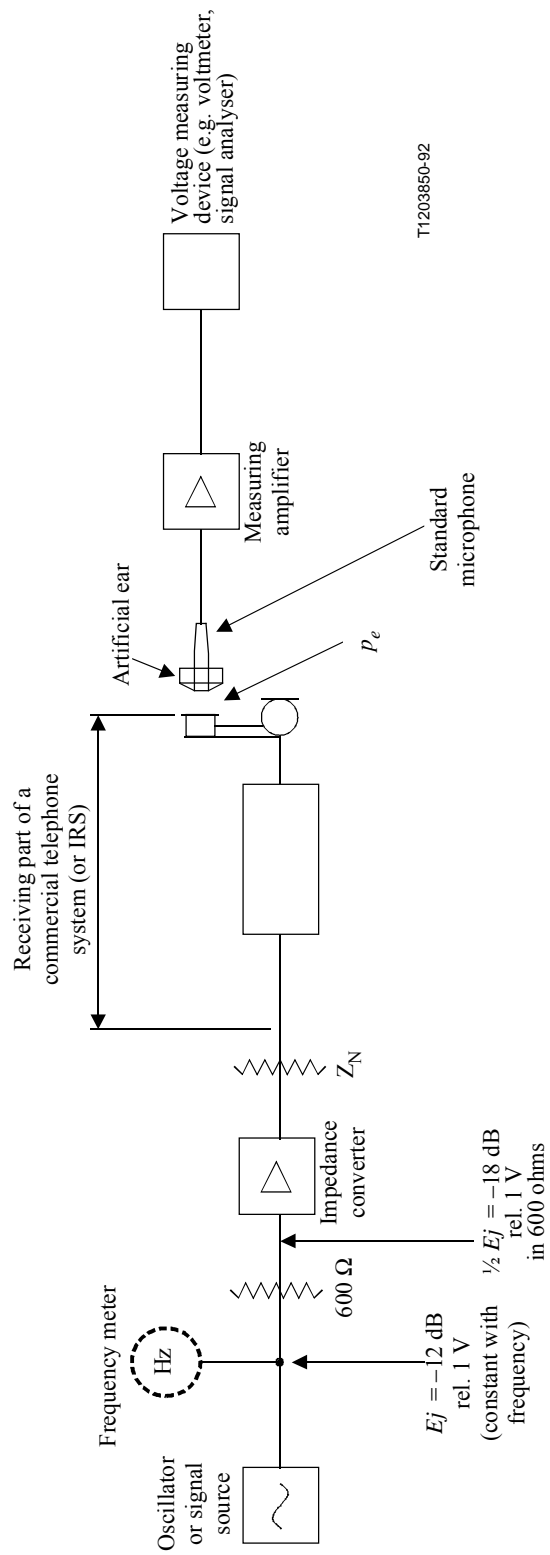

Figure B.1 – Voltage V_{JZ} measured across the terminals of an impedance converter connected to the output of a sending system under test
(Addition to Figure 2)



T1203850-92

Figure B.2/P.64 – Measurement of acoustic pressure P_e in the artificial ear developed by the receiving system under test connected to an impedance converter
(Addition to Figure 3)

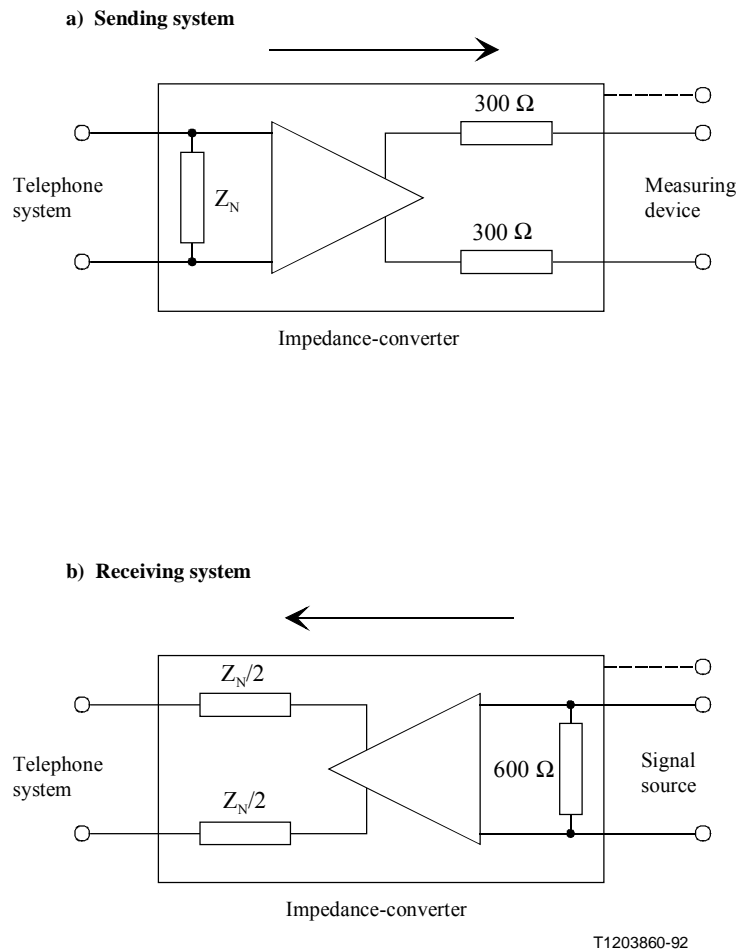

Figure B.3 – Impedance converter

B.3 Differences when measuring a telephone set with a complex impedance using 600 ohm terminations

Figure B.4 shows the equivalent electric circuits when the send and receive sensitivities of a telephone set with the impedance Z are measured with 600 ohm terminations. Figure B.5 depicts a typical configuration of Z , a nominal complex impedance (for the sake of simplification, it is assumed that the set impedance is exactly equal to this nominal impedance).

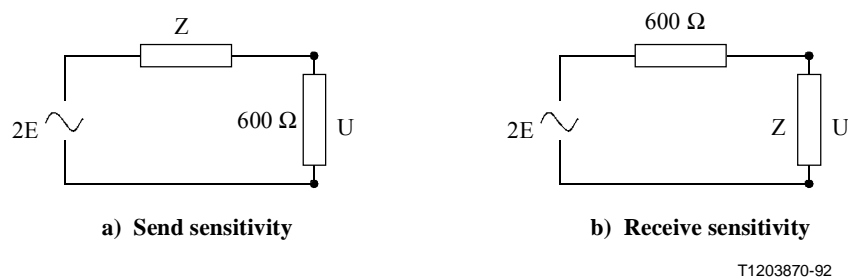

Figure B.4 – Equivalent electric circuits when measuring with 600 ohm terminations

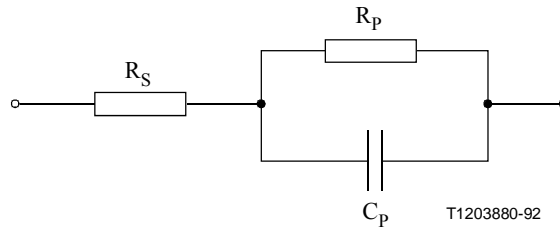

Figure B.5 – Configuration of complex nominal impedance Z

As an example, the following compromise nominal complex impedance Z has been adopted by ETSI:

$$R_S = 270 \text{ ohms}, \quad R_P = 750 \text{ ohms}, \quad C_P = 150 \text{ nF}$$

Figure B.6 shows the equivalent circuit when the correct termination Z is used.

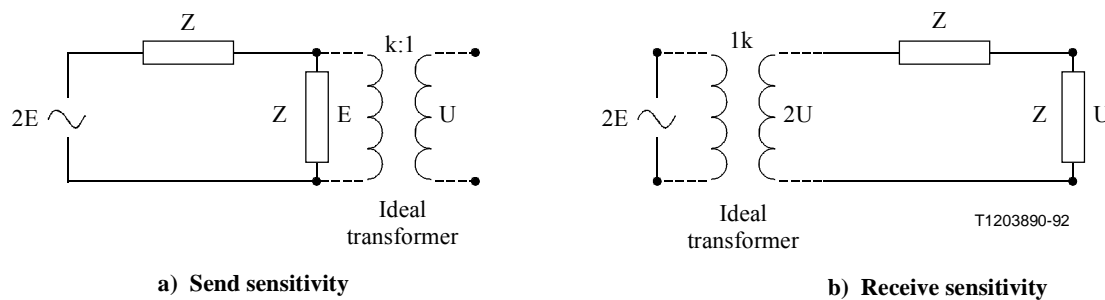

Figure B.6 – Equivalent electric circuits when measuring with Z terminations

The (notional) ideal transformers in Figure B.6 are used to bring the (absolute) impedance value at the reference frequency 1020 Hz to 600 ohms at the measuring interface. The winding ratio is k:1, where:

$$k = \sqrt{\left| \frac{Z(1020 \text{ Hz})}{600} \right|} \quad |Z(1020 \text{ Hz})| \text{ in ohms}$$

This corresponds to a dB correction of:

$$K = 20 \log_{10} k \text{ dB}$$

The voltage gain in Figure B.6 a) is:

$$20 \log_{10} \frac{U}{E} = -20 \log_{10} k = -K \text{ dB}$$

and in Figure B.6 b):

$$20 \log_{10} \frac{U}{E} = 20 \log_{10} k = K \text{ dB}$$

If 600 ohm terminations are used as in Figure B.4 instead of Z as in Figure B.6, certain differences will occur in the measured sensitivities.

For sending, the difference between the measured and the real sensitivity will be:

$$D_{send} = 20 \log_{10} \left| \frac{600 + Z(f)}{2600} \right| - K [\text{dB}]$$

and, correspondingly, for receiving:

$$D_{rec} = 20 \log_{10} \left| \frac{600 + Z(f)}{2 Z(f)} \right| + K[\text{dB}]$$

Annex C

Definition of the speaking position for measuring loudness ratings of handset telephones

(This annex forms an integral part of this Recommendation)

This annex describes the speaking position which should be used to measure the sensitivities of commercial telephone sets (by the method described in this Recommendation) for the determination of loudness ratings.

C.1 Geometry defining a speaking position

The definition of a speaking position falls into two parts: description of the relative positions of mouth opening and ear-canal opening on an *average* human head; and description of the angles that define the attitude in space of telephone handsets held to such a head. For any given telephone handset, these descriptions together describe the relative special disposition of the microphone opening and the talker's lips, and hence the direction in which speech sound waves arrive at the mouthpiece and the distance they have travelled from a virtual point source. The relative positions of the centre of the lips and that of the ear canal can be described in terms of a distance δ and an angle α as shown in Figure C.1. Point R in Figure C.1 represents the centre of a guard-ring located at the reference equivalent speaking position in accordance with historical measurement approaches. Position A is that used in historical approaches to determine ratings.

A second angle is required to define the direction in which speech is emitted from the mouth into the mouthpiece of the microphone. In traditional approaches, reference is made to an angle β , but this does not lie in the plane of symmetry of the handset, so it is more convenient to use an angle γ , which describes the vertical projection of the direction of speech on this plane.

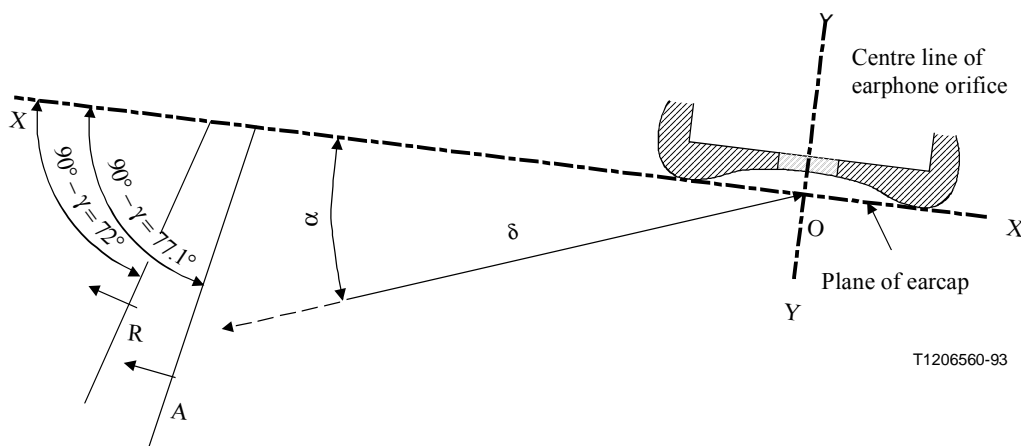

NOTE 1 – Points R and A are located as follows:

A) $\delta = 136 \text{ mm}$, $\alpha = 22^\circ$, $\gamma = 12.9^\circ$,

R) $\delta = 140 \text{ mm}$, $\alpha = 15.5^\circ$, $\gamma = 18^\circ$.

NOTE 2 – Solid lines through A and R show plane of lips.

Figure C.1 – Location of lip position relative to opening of ear canal

C.2 Geometry defining a change in speaking position

The position of the centre of the lips as defined by A in Figure C.1 is used also to define the new speaking position, but two additional angles must also be defined, namely: the earphone rotational angle Φ and the handset rotational angle Θ . Earphone rotation is considered about an axis through the centre of the earcap (YY in Figure C.1); handset rotation is taken about a longitudinal axis of the handset (XX in Figure C.1); both angles are zero when the plane of symmetry of the handset is horizontal. Naturally, the earphone rotational angle is positive when the handle is pointed downwards away from the earphone and the handset rotational angle is positive in the sense that the upper part of the earphone is moved farther from the medial plane of the head.

The new speaking position is described by the following values for the distance and angles defined above:

$$\alpha = 22^\circ, \gamma = 12.9^\circ, \delta = 136 \text{ mm}, \Phi = 39^\circ \text{ and } \Theta = 13^\circ.$$

The angle γ cannot be determined very precisely and is not convenient for use when setting up a handset for test in front of an artificial mouth. The semi-interaural distance ϵ may be used in its place, and for the new speaking position $\epsilon = 77.8 \text{ mm}$.

For any test jig, the manufacture tolerance should be within $\pm 0.5^\circ$ for the angles defined above.

C.3 Simplification through the use of the position of the ear reference point

The foregoing description of the speaking position has shown the complexities of expressing the relative location of the ear reference point and the guard-ring centre, and the relative orientation of the earphone axis and the guard-ring axis. It is often more convenient, particularly in terms of constructing and setting-up handset jigs, to express the position of the ear reference point² and the direction of the earphone axis with respect to the lip-ring. This is easier since the axis of the guard-ring is horizontal as would be the axis of an associated artificial mouth.

C.4 Vector representation of the reference points

Use has been made of a vector analysis method to determine the orthogonal coordinates of the handset earcap relative to the lip position when the handset is mounted in the LR guard-ring position. It is necessary to define a set of Cartesian axes with origin at the centre of the lips (or equivalent lip position of an artificial voice) as follows:

- x-axis: horizontal axis of the mouth, with positive direction into the mouth;
- y-axis: horizontal, perpendicular to the x-axis, with positive direction towards the side of the mouth on which the handset is held;
- z-axis: vertical, with positive direction upwards.

The ear reference point is defined by the vector:

$$(86.53, 77.75, 70.45) \text{ mm}$$

The handset is mounted so that the ear reference point lies at the intersection of the axis of the earcap with a plane in space on which the earcap can be considered to be resting. With some shapes of handset, this definition is not adequate; in such cases, the position of the ear reference point relative to the handset should be clearly stated.

The orientation of the handset is defined by vectors normal to the plane of the earcap and the plane of symmetry of the handset:

Unit vector normal to plane of the earcap:

² See Annex A for definition of ear reference point.

$$\pm (0.1441, -0.9740, 0.1748)$$

Unit vector normal to plane of symmetry of the handset:

$$\pm (0.6520, -0.0394, -0.7572)$$

When using an artificial voice, the equivalent lip position must be used as the datum; this is not normally the same as the plane of the orifice of the artificial mouth.

Alternatively, it can be convenient to define the speaking position in terms of axes with the origin at the ear reference point. These are defined as follows:

- x-axis: axis of earcap with positive direction away from earphone;
- y-axis: line of intersection of the plane of symmetry of the handset with the earcap plane, with positive direction towards the microphone;
- z-axis: normal to the plane of symmetry of the handset with positive direction obliquely upwards.

The lip-ring centre is defined by the vector:

$$(50.95, 126.10, 0.00) \text{ mm.}$$

The orientation of the lip-ring is defined by a unit vector along its axis:

$$\pm (0.1441, -0.7444, -0.6520)$$

and the orientation of the handset is defined by specifying the vertical by the unit vector:

$$\pm (0.1748, -0.6293, +0.7572).$$

NOTE 1 – The speaking position defined above differs from the special guard-ring position in the values of $\Phi (= 37^\circ)$ and $\Theta (= 19^\circ)$. It has been found that altering the handset position from the special guard-ring position to the loudness rating guard-ring position described above affects sensitivity measurements to a negligible extent.

NOTE 2 – The term "loudness rating guard-ring position" (LRGP) is to be used only when the definition described in this annex is strictly followed. It should be stressed that not only the relative position between the handset and the mouth should be followed, but also the mouth should be horizontal.

Annex D

Definition of handset positions for measuring loudness ratings and frequency responses using the P.57 type 3.4 artificial ear on HATS

(This annex forms an integral part of this Recommendation)

D.1 General

This annex describes three handset positions which should be used to measure the sensitivities of commercial telephone sets in sending and receiving directions. The first position described in this annex is the standard position compatible to the LRGP position in terms of sending sensitivity. The second one is an alternative position which can be applied for very flat (e.g., mobile) handsets which may touch the head outside the pinna area in case the standard position is used. The third position is an alternative position allowing more flexibility.

The handset positions are defined according to the procedure described in Annex C. The orientation of the handset is defined by a vector normal to the plane of the ear cap (\vec{n}_{EC}) and a vector normal to the plane of symmetry of the handset (\vec{n}_{HS}), as shown in Figure D.1.

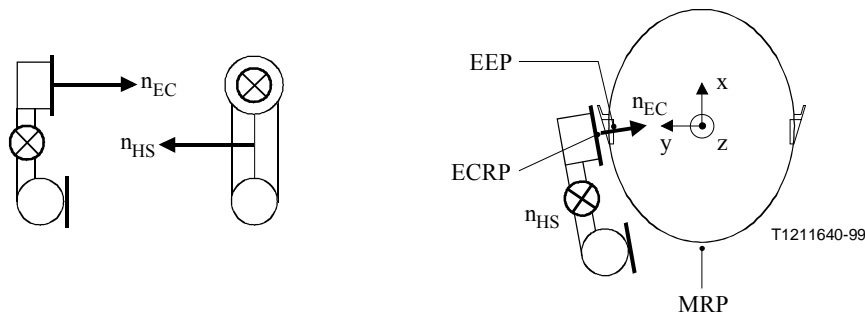

Figure D.1 – Definition of unit vectors \vec{n}_{EC} and \vec{n}_{HS} relative to handset (left) and in connection to HATS (right)

In Figure D.1, in addition to the ear canal entrance point (EEP), the centre of the earcap (ECRP) and the mouth reference point (MRP) are indicated.

D.2 Definition of the standard handset position

The standard position is defined by the following vectors:

- 1) Unit vector normal to the plane of the ear cap:

$$\vec{n}_{EC} = \pm (+0.1771, -0.9842, +0.0086)$$

- 2) Unit vector normal to plane of the symmetry of the handset:

$$\vec{n}_{HS} = \pm (+0.4083, +0.0655, -0.9105)$$

The relative position between EEP and plain of lips is defined in [ITU-T P.58]. The ECRP is shifted from the EEP by +8.0 mm in x-direction and +10.0 mm in z-direction. When coupling normal-shaped, flat earcaps to the artificial ear, the ERP would approximate to the position taken up by the ECRP.

NOTE – The handset is moved in y-direction in order to apply different pressure force to the ear.

D.3 Definition of the flat handset position

For some recent handsets, especially for mobile phones, this position may be impossible, since α may be too large. For that case, a flat handset position can be used, with α decreased by 5° . The vectors for that second position are:

- 1) Unit vector normal to the plane of the ear cap:

$$\bar{n}_{EC} = \pm (+0.09066, -0.99587, +0.00869)$$

- 2) Unit vector normal to plane of the symmetry of the handset:

$$\bar{n}_{HS} = \pm (+0.41214, +0.02957, -0.91067)$$

The relative position between EEP and plain of lips is defined in [ITU-T P.58]. The centre of the earcap is shifted from the EEP by +8.0 mm in x-direction and +10.0 mm in z-direction; thus, the alternative position shows the same displacement as the standard position described in clause D.2.

NOTE – The handset is moved in y-direction in order to apply different pressure force to the ear.

D.4 Definition of the alternative handset position for measuring loudness ratings and frequency responses using the P.57 type 3.4 artificial ear on HATS

This clause describes an alternative handset position to be used when measuring sensitivity/frequency characteristics of local telephone systems using HATS. In the case that the standard handset position as defined in clause D.2, or the flat handset position as defined in clause D.3, is found to poorly represent human usage of a handset, the following alternative position may be defined.

The unit vectors defining the coordinate system of the handset and handset positioner are defined in clause E.1 as x_e , y_e and z_e . Additionally, rotation degrees of freedom, as illustrated in Figure E.1 are defined as follows:

- Rotational degree of freedom A is defined as a clockwise rotation about the x_e unit vector.
- Rotational degree of freedom B is defined as a clockwise rotation about the z_e unit vector.
- Rotational degree of freedom C is defined as a clockwise rotation about the y_e unit vector.

The manufacturer-defined earcap reference point (MECRP) allows for a new point to be defined on the surface of the phone. The MECRP is defined with respect to the ECRP and allows the displacement along the z_e and y_e unit vectors only. The pressure force employed to hold the handset to the HATS will define the position of the handset along the y_m axis.

The acceptable range of offset of the MECRP shall not exceed:

- +8/–10 mm along unit vector y_e .
- ± 10 mm along unit vector z_e .

NOTE 1 – Care should be taken in order not to choose a position where the sound outlet of the phone is located outside the concha cavity of the 3.4 artificial ear.

The acceptable range of handset rotations about the MECRP shall not exceed:

- $\pm 6^\circ$ in rotational degree of freedom A.
- $\pm 6^\circ$ in rotational degree of freedom B.
- $\pm 5^\circ$ in rotational degree of freedom C.

NOTE 2 – In exceptional cases for handsets showing a design where even these ranges for offset and rotation do not allow a close to human-use positioning these ranges may be exceeded. Sufficient justification for such deviation shall be given.

The procedure for defining an alternative position is defined as a two-step process. Firstly, the handset MECRP is to be defined, allowing an offset along the z_e and y_e unit vectors only. In many

cases, this will suffice to provide a placement of the handset on the HATS which is similar to human usage. The MECRP may be coincident with the ECRP.

However, with certain handset form-factors, additional angular rotations may be required to achieve correct placement. Secondly, the angular rotations shall occur about the MECRP. Thirdly, the application force is applied by moving the handset in y_m -direction.

In order to ensure that the alternative position is unambiguously defined for a given handset type and to ensure that the alternative position can be repeated in any laboratory, the reporting format described in Table D.1 shall be used.

In the standard position, angles A, B and C are defined as the deviation to the unit vectors y_e and z_e from the HATS reference plane and the HATS plane of symmetry. The planes are shown in Figure 1 of [ITU-T P.58]. The values for angles A, B and C for handsets in the standard position are 24.4, -10.5 and 0.5 degrees, respectively, as defined in clause D.2. For the flat handset position, angle B is modified to be -5.5 degrees, as defined in clause D.3. The adjustment tolerances refer to deviations from the standard position angles.

Table D.1 – Template structure for reporting the alternative handset position when using the P.57 type 3.4 artificial ear on HATS

MECRP (delta from actual ECRP)

Axis	Delta [mm]
y_e	
z_e	

Angle settings

Angle	Delta from standard angle [°]
A	
B	
C	

Application force [N]	
-----------------------	--

If the handset manufacturer selects to use either the standard position (as defined in clause D.2), the flat handset position (as defined in clause D.3) or the alternative position (as defined in this clause), this uniquely-defined position shall be used for all measurements associated with this handset type.

Annex E

Definition of handset positions for measuring loudness ratings and frequency responses using the P.57 types 3.2 and 3.3 artificial ear on HATS

(This annex forms an integral part of this Recommendation)

E.1 Definition of standard handset position for measuring loudness ratings and frequency responses using the P.57 types 3.2 and 3.3 artificial ear on HATS

This clause describes the handset position to be used when measuring sensitivity/frequency characteristics of local telephone systems using HATS. The HATS position has been shown to be essentially identical to the LRGP position, except for the mouth speaking direction, which has been corrected with a 19 degrees downwards rotation.

A Cartesian coordinate system with origin in the centre of lips (CL) is introduced. The x_m axis coincides with the mouth reference axis, and has positive direction into the mouth. The y_m axis is horizontal, perpendicular to the x_m axis, with positive direction towards the right side of the mouth/test head. The z_m axis is perpendicular to the x_m and y_m axes and with positive direction upwards (refer to Figure E.1). This head-fixed, mouth coordinate system is used. It is parallel to the Frankfurter plane and the HATS reference plane.

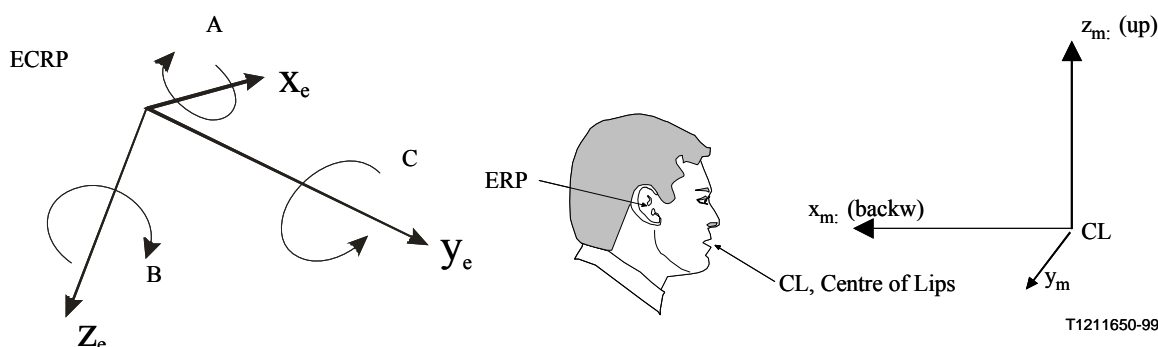

Figure E.1 – Cartesian coordinate systems

NOTE – For the standard HATS position, ERP and ECRP are coincident.

Figure E.1 also shows the ECRP-based Cartesian coordinate system with the axes:

- x_e axis: axis of earcap with positive away from the earphone (into the ear).
- y_e axis: line of intersection of the handset symmetry plane with the earcap plane. Positive direction towards the microphone.
- z_e axis: normal to the two other axes. On the right ERP pointing obliquely downwards.

The standard HATS position is defined by the following vectors:

$$\text{CL-ERP (nominal, right side)} = \begin{bmatrix} x_m \\ y_m \\ z_m \end{bmatrix} = \begin{bmatrix} 110.0 \\ 77.9 \\ 40.3 \end{bmatrix}$$

$$\text{EEP-ERP vector (nominal, right side)} = \begin{bmatrix} x_m \\ y_m \\ z_m \end{bmatrix} = \begin{bmatrix} 6.0 \\ 11.9 \\ -1.7 \end{bmatrix}$$

$$x_e \text{ unit vector} = \begin{bmatrix} x_m \\ y_m \\ z_m \end{bmatrix} = \begin{bmatrix} 0.1932 \\ -0.9740 \\ 0.1184 \end{bmatrix}$$

$$y_e \text{ unit vector} = \begin{bmatrix} x_m \\ y_m \\ z_m \end{bmatrix} = \begin{bmatrix} -0.9088 \\ -0.2231 \\ -0.3527 \end{bmatrix}$$

$$z_e \text{ unit vector} = \begin{bmatrix} x_m \\ y_m \\ z_m \end{bmatrix} = \begin{bmatrix} 0.3699 \\ -0.0394 \\ -0.9282 \end{bmatrix}$$

For the HATS position, the nominal CL-ERP distance is 140.7 mm.

E.2 Definition of the alternative handset position for measuring loudness ratings and frequency responses using the P.57 type 3.3 artificial ear on HATS

This clause describes an alternative handset position to be used when measuring sensitivity/frequency characteristics of local telephone systems using HATS. In the case that the standard handset position as defined in clause E.1 is found to poorly represent human usage of a handset, the following alternative position may be defined.

The unit vectors defining the coordinate system of the handset and handset positioner are defined in clause E.1 as x_e , y_e and z_e . Additionally, rotation degrees of freedom, as illustrated in Figure E.1 are defined as follows:

- Rotational degree of freedom A is defined as a clockwise rotation about the x_e unit vector.
- Rotational degree of freedom B is defined as a clockwise rotation about the z_e unit vector.
- Rotational degree of freedom C is defined as a clockwise rotation about the y_e unit vector.

The manufacturer-defined earcap reference point (MECRP) allows for a new point to be defined on the surface of the phone. The MECRP is defined with respect to the ECRP and allows displacement along the z_e and y_e unit vectors only. The pressure force employed to hold the handset to the HATS will define the position of the handset along the y_m axis.

The acceptable range of offset of the MECRP shall not exceed:

- +15/−10 mm along unit vector y_e .
- ±10 mm along unit vector z_e .

The acceptable range of handset rotations about the MECRP shall not exceed:

- ±6° in rotational degree of freedom A.
- ±6° in rotational degree of freedom B.
- ±5° in rotational degree of freedom C.

NOTE – In exceptional cases for handsets showing a design where even these ranges for offset and rotation do not allow a close to human-use positioning, these ranges may be exceeded. Sufficient justification for such deviation shall be given by the manufacturer and/or the test laboratory. The procedure for defining an alternative position is defined as a two-step process. Firstly, the handset MECRP is to be defined, allowing an offset along the z_e and y_e unit vectors only. In many cases this will suffice to provide a placement of the handset on the HATS which is similar to human usage. The MECRP may be coincident with the ECRP. However, with certain handset form-factors, additional angular rotations may be required to achieve correct placement. Secondly, the angular rotations shall occur about the MECRP. Thirdly the application force is applied by moving the handset in y_m -direction.

In order to ensure that the alternative position is unambiguously defined for a given handset type and to ensure that the alternative position can be repeated in any laboratory, the reporting format described in Table E.1 shall be used.

In the standard position, angles A, B and C are defined as the deviation to the unit vectors y_e and z_e from the HATS reference plane and the HATS plane of symmetry. The planes are shown in Figure 1 of [ITU-T P.58]. The values for these angles in the standard position are 21.2, -12.9 and 2.3 degrees for angles A, B and C, respectively, and with the right ear. The adjustment tolerances refer to deviations from the standard position angles.

Table E.1 – Template structure for reporting the alternative handset position when using the P.57 3.3 artificial ear on HATS

MECRP (delta from actual ECRP)

Axis	Delta [mm]
y_e	
z_e	

Angle settings

Angle	Delta from standard angle [°]
A	
B	
C	

Application force [N]	
-----------------------	--

If the handset manufacturer selects to use either the standard position (as defined in clause E.1) or the alternative position (as defined in this clause), this uniquely-defined position shall be used for all measurements associated with this handset type.

Annex F

Correspondence between measurements using the LRGP and the HATS position

(This annex forms an integral part of this Recommendation)

$S_{je}(f)$ and $S_{mj}(f)$ measurements on typical telephones using ordinary pressure microphones (300-3400 Hz) are expected to give practically identical results whether obtained with LRGP or the HATS position. Small sensitivity increases on HATS are expected to reflect larger (3%) head size.

Systematic differences of about 1-2 dB in $S_{mj}(f)$ measurements on pressure gradient microphones have to be expected from the upwards-tilted speaking direction of about 19° using the LRGP position.

If the closest possible correspondence between test head and HATS measurements are to be obtained, the HATS position should be used on both devices.

Bibliography

- [b-IEC 60318-1] IEC 60318-1 (1998), *Electroacoustics – Simulators of human head and ear – Part 1: Ear simulator for the calibration of supra-aural earphones*.
<[http://webstore.iec.ch/webstore/webstore.rsf/artrum/023106](http://webstore.iec.ch/webstore/webstore.rsrf/artrum/023106)>
- [b-ITU-T Handbook] ITU-T Handbook (1992), *Handbook on Telephony*.

SERIES OF ITU-T RECOMMENDATIONS

Series A	Organization of the work of ITU-T
Series D	General tariff principles
Series E	Overall network operation, telephone service, service operation and human factors
Series F	Non-telephone telecommunication services
Series G	Transmission systems and media, digital systems and networks
Series H	Audiovisual and multimedia systems
Series I	Integrated services digital network
Series J	Cable networks and transmission of television, sound programme and other multimedia signals
Series K	Protection against interference
Series L	Construction, installation and protection of cables and other elements of outside plant
Series M	Telecommunication management, including TMN and network maintenance
Series N	Maintenance: international sound programme and television transmission circuits
Series O	Specifications of measuring equipment
Series P	Telephone transmission quality, telephone installations, local line networks
Series Q	Switching and signalling
Series R	Telegraph transmission
Series S	Telegraph services terminal equipment
Series T	Terminals for telematic services
Series U	Telegraph switching
Series V	Data communication over the telephone network
Series X	Data networks, open system communications and security
Series Y	Global information infrastructure, Internet protocol aspects and next-generation networks
Series Z	Languages and general software aspects for telecommunication systems