



INTERNATIONAL TELECOMMUNICATION UNION

ITU-T

TELECOMMUNICATION
STANDARDIZATION SECTOR
OF ITU

Q.1111

(03/93)

**INTERWORKING WITH SATELLITE
MOBILE SYSTEMS**

**INTERFACES BETWEEN THE INMARSAT
STANDARD B SYSTEM AND THE
INTERNATIONAL PUBLIC SWITCHED
TELEPHONE NETWORK/ISDN**

ITU-T Recommendation Q.1111

(Previously "CCITT Recommendation")

FOREWORD

The ITU Telecommunication Standardization Sector (ITU-T) is a permanent organ of the International Telecommunication Union. The ITU-T is responsible for studying technical, operating and tariff questions and issuing Recommendations on them with a view to standardizing telecommunications on a worldwide basis.

The World Telecommunication Standardization Conference (WTSC), which meets every four years, established the topics for study by the ITU-T Study Groups which, in their turn, produce Recommendations on these topics.

ITU-T Recommendation Q.1111 was revised by the ITU-T Study Group XI (1988-1993) and was approved by the WTSC (Helsinki, March 1-12, 1993).

NOTES

1 As a consequence of a reform process within the International Telecommunication Union (ITU), the CCITT ceased to exist as of 28 February 1993. In its place, the ITU Telecommunication Standardization Sector (ITU-T) was created as of 1 March 1993. Similarly, in this reform process, the CCIR and the IFRB have been replaced by the Radiocommunication Sector.

In order not to delay publication of this Recommendation, no change has been made in the text to references containing the acronyms "CCITT, CCIR or IFRB" or their associated entities such as Plenary Assembly, Secretariat, etc. Future editions of this Recommendation will contain the proper terminology related to the new ITU structure.

2 In this Recommendation, the expression "Administration" is used for conciseness to indicate both a telecommunication administration and a recognized operating agency.

© ITU 1994

All rights reserved. No part of this publication may be reproduced or utilized in any form or by any means, electronic or mechanical, including photocopying and microfilm, without permission in writing from the ITU.

CONTENTS

	<i>Page</i>
1 General	1
2 Service capabilities.....	1
2.1 Channel capabilities.....	1
2.2 INMARSAT Standard-B bearer capabilities	1
2.3 Teleservices	2
3 Interworking scenarios	2
4 Connection interface requirements.....	4
4.1 General.....	4
4.2 MSSC-network interface	4
4.3 SES-MSSC interface	4
4.4 Terminal to ship earth station interface	4
4.5 Calling procedures	5
5 Routing requirements	7
6 Maritime and supplementary services	7
6.1 Maritime services available via INMARSAT.....	7
6.2 Supplementary services	7
Appendix I – INMARSAT Standard-B mobile-satellite system description.....	8
I.1 Introduction	8
I.2 Channel configurations.....	8
I.3 Access control and signalling sub-system	12
I.4 Communications sub-system	13
I.5 Link layer formats and protocols	14
I.6 Telephone services.....	15

INTERFACES BETWEEN THE INMARSAT STANDARD B SYSTEM AND THE INTERNATIONAL PUBLIC SWITCHED TELEPHONE NETWORK/ISDN

(Melbourne, 1988; modified at Helsinki, 1993)

1 General

1.1 This Recommendation includes information on the services offered in the ISDN relevant to the Standard-B INMARSAT system and describes the requirements for connection and internetworking with the public networks. Special terminology for this Recommendation is defined in Recommendation Q.1100.

Detailed interworking procedures are set out in Recommendation Q.1112.

NOTE – Recommendations Q.1101, Q.1102 and Q.1103 define the interworking procedures for the Standard-A INMARSAT system.

1.2 In addition to providing the capability to interwork using common channel signalling techniques between the terrestrial ISDN and the Standard-B INMARSAT system, due regard should be paid to the open systems interconnection reference model (X.200-Series Recommendations) and ISDN services and signalling methods (I-Series Recommendations) with a view to achieving uniformity in user procedures and formats, and to achieving generally applicable facilities.

1.3 Within the constraint of the need to operate as economically as possible, the preferred interworking cases are with the ISDN and with those parts of the international telephone network employing common channel signalling. If these cases do not exist at the ISC to which an MSSC is connected then another signalling system from the Q-Series Recommendations should be used.

1.4 The use of the ISDN for call connect purposes from the MSSC to the fixed user is expected to offer both improvements in quality and more flexibility in service.

2 Service capabilities

A general description of the INMARSAT Standard-B system is contained in Appendix I.

2.1 Channel capabilities

The system supports a range of channel capabilities as follows:

- single channel per carrier (SCPC) communication channels;
- time division multiplex/time division multiple access (TDM/TDMA) communication channels and random access (RA) channels with information bit rates of up to 16 kbit/s.

Further capabilities may be supported in the future, e.g. channels with information bit rates of up to 64 kbit/s. The services supported by each channel type are indicated in the following subclauses.

2.2 INMARSAT Standard-B bearer capabilities

2.2.1 SCPC channels

The following bearer services on SCPC channels with an information transfer rate attribute of 16 kbit/s and 9.6 kbit/s and with the following information transfer attributes corresponding to those defined in Recommendation I.211 should be supported:

- a) Speech at 16 kbit/s and optionally at 9.6 kbit/s.
- b) Circuit mode 3.1 kHz audio services at 16 kbit/s (Transcoding to the circuit mode 64 kbit/s, 8 kHz structured bearer service, usable for 3.1 kHz audio information, of Recommendation I.211, should take place in the MSSC).

- c) Virtual call bearer service at an information bit rate of 16 kbit/s.
- d) Digital data, circuit mode service at an information bit rate up to 9.6 kbit/s for facsimile service.

2.2.2 TDM/TDMA channels

The following bearer services on TDM/TDMA channels should be supported with information transfer rates of 0.05, 0.3 for telex and low speed data respectively:

- a) Telex – Interworking with the ISDN should take place as defined in Recommendation U.202;
- b) Virtual call bearer service – Interworking with the ISDN should take place as defined for interworking between PSPDNs and the ISDN;
- c) Digital data, circuit mode – Interworking with the PSTN should take place as defined in the appropriate PSTN signalling system;

NOTE – Adaptors designed to CCITT Recommendations may not support call set-up for ship earth station terminating calls. This requires further study by INMARSAT.

- d) Digital data, asynchronous circuit mode symmetric – For further study by INMARSAT.
- e) Digital data, asynchronous circuit mode, asymmetric – For further study by INMARSAT.

2.2.3 RA channels

The following bearer services on random access channels may be supported:

- a) Connectionless data service – For further study by INMARSAT.

2.3 Teleservices

Teleservices should be supported as defined in Recommendation I.212. It is to be observed that not all teleservices of ISDN may be supported with bearer services that can be provided on SCPC or TDM/TDMA channels operating at net bit rates of 16 kbit/s or less.

3 Interworking scenarios

Three interworking scenarios can be envisaged for the interface between the MSSC and the fixed networks.

3.1 The first of these is shown in Figure 1. No interworking is envisaged between the MSSC and the ISDN, with the MSSC interfaced directly to the telex, public switched telephone and public data networks. In this scenario interworking with the PSTN supports speech and 3.1 kHz audio services.

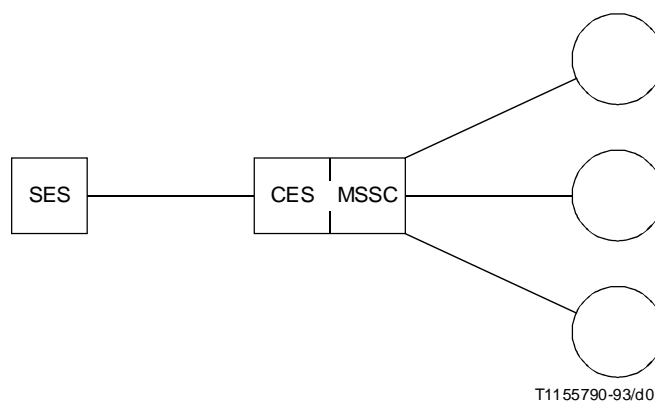

FIGURE 1/Q.1111
Interworking scenario with no ISDN interfaces

3.2 Figure 2 shows the situation where an ISDN exists and the MSSC has an interface to it. Interworking with the PSTN is achieved via the ISDN. Interworking with PDNs may be by direct interface with the PDN or via the ISDN, as in the cases of the PSTN. A direct interface will be required for interworking with the telex network.

In this scenario interworking with the ISDN supports speech, 3.1 kHz audio and data services as indicated in 2.2.1. Other data services as indicated in 2.2.2 and 2.2.3 may require interworking with PDNs.

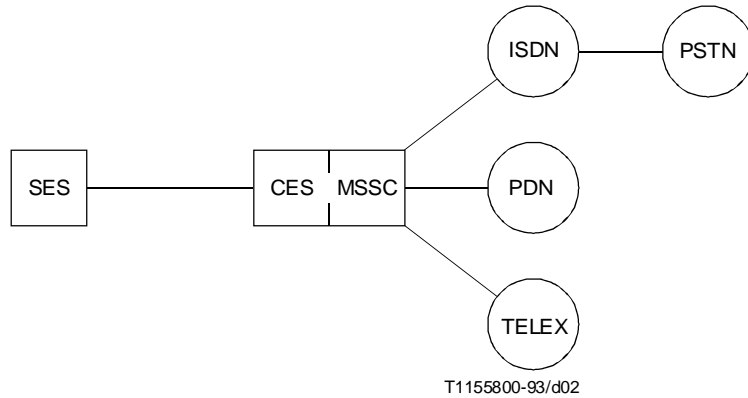

FIGURE 2/Q.1111
Interim interworking scenario with interfaces to ISDN and other fixed networks

3.3 In the fully integrated interworking scenario the MSSC interfaces only to the ISDN. This is the preferred scenario and is illustrated in Figure 3. Interworking with the PSTN and the PDNs is achieved via the ISDN interface. However, interworking with the telex network may require a direct interface between the MSSC and the telex network.

In this scenario also, data services as indicated in 2.2.2 and 2.2.3 are converted to formats which correspond to bearer services in the ISDN. The MSSC may then contain adaptors with functions equivalent to those defined for the ISDN.

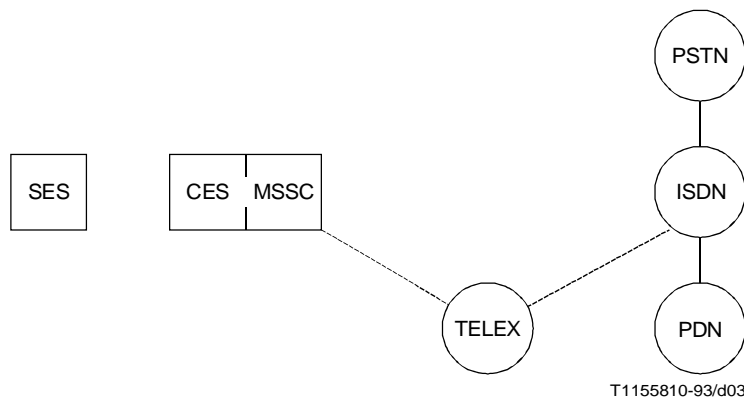

FIGURE 3/Q.1111
Interworking scenario with interface to ISDN only

4 Connection interface requirements

4.1 General

This subclause identifies the information that must be available at the interfaces between the ship earth station (SES) and the MSSC and between the MSSC and the fixed network, principally for the connection of services identified in 4.3.

4.2 MSSC-network interface

For ISDN connections ISUP should be used for message transfer. For non-ISDN or where ISUP is not available, TUP would be preferred.

If information transport between MSSCs over the fixed network is required, it is suggested that the procedures of the SCCP are used. Detailed interworking procedures are defined in Recommendation Q.1112.

4.3 SES-MSSC interface

Prior to and during call initiation the signalling channel functions may be provided by one or more common control channels.

A signalling capability should always be available during conversation in case it is needed for call clearing, call control, or for call management purposes. During a call the signalling channel may be multiplexed with the traffic channel at a lower bit rate so as to conserve radio channel capacity.

The multiplexed signalling channel on TDM/TDMA/RA channels may be used for bearer services such as connectionless data services, or connection oriented data services not requiring the establishment of a traffic channel.

The traffic channel should be used for bearer services such as:

- speech;
- circuit mode data services (including facsimile);
- packet mode data service;
- voice band data services.

4.4 Terminal to ship earth station interface

4.4.1 Non-ISDN interface

A configuration for non-ISDN terminals is shown in Figure 4. Digits may be entered either from telephone hand sets, or data terminals, which use Q.23 tone signalling formats. The signalling interface between the ship earth station and the terminals must also provide a means for detecting the hook-on/off condition. The line connection to the terminal from the ship earth station may use either analogue or digital techniques.

The ship earth station must convert both the signalling (digits and on/off-hook) information and the line connection format (analogue or digital) into the protocols used on the radio path.

4.4.2 ISDN interface

A typical example of the type of interface required could be as shown in Figure 5. In this case the ship earth station needs to provide a function equivalent to NT2 of the ISDN for termination of the ISDN basic access (see Recommendation I.420).

When CCITT No. 7 (ISUP) is used for interconnection at the MSSC, the coding of call failure causes used on the satellite channels will be in accordance with Recommendation Q.931.

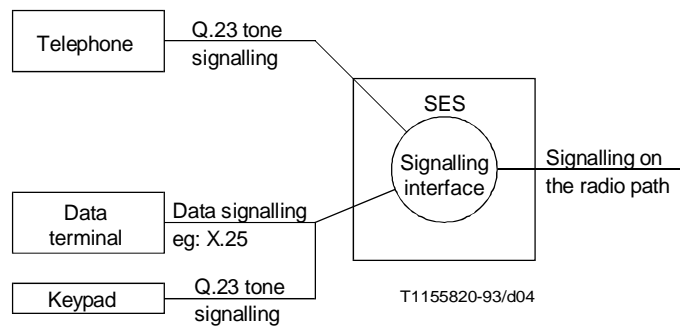

FIGURE 4/Q.1111
SES signalling interface for non-ISDN terminals

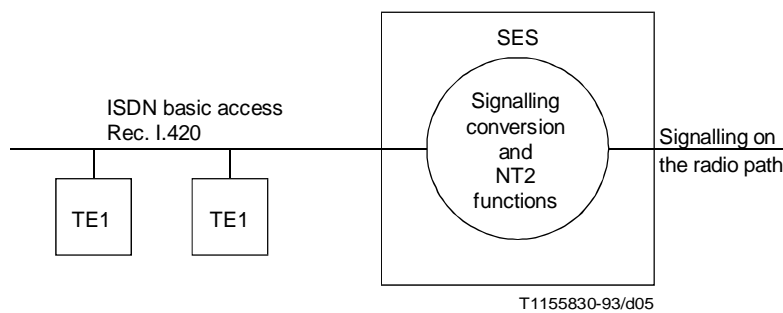

FIGURE 5/Q.1111
SES signalling interface for ISDN terminals

4.5 Calling procedures

4.5.1 Ship-to-shore call

a) *Information elements on the radio path*

The ship earth station should include the following information in the “access request” message:

- the CES address to which the request is being sent;
- connection request;
- bearer capabilities;
- special category indication such as priority, etc.;
- special user facilities.

This will be followed by the “service address” message, containing the called party address. In order to expedite the call set-up, all digits (and other information) will be entered into the ship earth station terminal prior to the request to the MSSC to set up the call.

b) *Information elements on the fixed network*

The MSSC in addition to the information provided, should also add the following where the signalling system supports it:

- continuity indicator;
- echo suppressor indicator;
- satellite indicator.

The call should then be progressed by the MSSC in the normal manner, with the following indications being returned to the ship earth station upon receipt from the network:

- called party answer;
- failure cause indicator (information indicating the cause for the failure of an unsuccessful call attempt);
- clearing signal.

The answer signal, clearing signal or channel release signal, and called party address may be used by the ship earth station to generate charging information. On receipt of a message with a cause indicator, the ship earth station should generate the appropriate audible tones (see Recommendation Q.35), and/or visible message information if an ISDN terminal is used.

c) *Clearing of call*

If the ship earth station wishes to clear a call, the ship earth station terminal should generate a “channel release” message to the MSSC. The MSSC should forward this to the network to release connections in the ISDN. The MSSC should receive a “release complete” message from the fixed network.

The MSSC should also deal with a “call release” message from the network. A “channel release” message should be forwarded to the ship earth station to clear the connection and a “release complete” message should be generated to return to the network.

Special facilities for “malicious call” detection needs further study.

For ship originated calls normal clearback procedures should apply (see Recommendation Q.118) when interworking with the PSTN with the supervision applied at the MSSC. Handling of suspend/resume messages to and from the ISDN requires further study by INMARSAT.

4.5.2 Shore subscriber initiated call

a) *Deletion of country code*

In most cases the MSSC will not need the information contained in the S-digit of the country code 87S. In this situation the sequence of forward-address information sent to the MSSC should be as for a terminal international call. However, if the MSSC requires the S-digit to distinguish between ocean areas, the forward-address information should include the country code 87S, as for an international transit call.

b) *General interworking procedure*

The MSSC upon receipt of a “request connection” message should use the information contained to determine the called ship's number. A call should then be generated to the SES on the signalling channel. The ship earth station should reply with a “response message”. A “connect signal” message is sent when the “answer” message is received from the called terminal.

The MSSC should on receipt of these signals generate a “called party answer” message, or insert the relevant “cause indicator”.

Call clearing by either party will be as indicated previously.

4.5.3 MSSC control functions

- a) The MSSC should always perform a continuity check on the satellite circuit before connecting a circuit into the ISDN.

b) *Control of echo control devices*

Since all calls to and from a ship earth station will include a satellite link, appropriate actions must be taken, when necessary, to insert an incoming or outgoing echo control device in the circuit. This may be carried out either at the MSSC, or within an international exchange in the fixed network. The ship earth station will normally connect to the satellite link on a 4-wire basis (see Recommendation Q.115), but where necessary (e.g. for 2-wire extensions), will incorporate the equivalent of an echo control device. In order to reduce the analysis and control requirements at the MSSC it may prove convenient to carry out control of all echo control devices at the international exchanges rather than at the MSSC.

c) *Barring of group call numbers*

Barring of calls having group call numbers, from unauthorized users, shall be provided at the MSSC. However, in order to avoid the setting up of the international chain for unauthorized group calls from ordinary subscribers, barring of such calls should, as a general rule, be done at the ISC of origin.

d) *Barring of calls to/from individual ship earth stations*

The MSSC should have the capability of barring calls to or from individual ship earth stations. Such barring shall not apply to distress priority calls.

5 Routing requirements

5.1 Avoiding two or more satellite links in tandem.

5.1.1 Shore originated calls

The country code 87S should be analysed at all transit centres where the call may either be routed on a circuit containing a satellite link or on a circuit not containing a satellite link. The latter circuit should always be chosen (see Recommendation Q.14).

5.1.2 Ship originated calls

If the signalling system provided between the MSSC and the terrestrial network contains signals which may be used to indicate that one satellite link is included, such signals should be used.

If the signalling system does not contain such signals, the outgoing ISC should avoid forwarding the call on an outgoing circuit which includes a satellite link. If, however, the signalling system employed between the outgoing ISC and the next ISC in the connection contains such signals, the outgoing ISC should insert the required information. The outgoing ISC could base its procedure upon incoming route identification.

6 Maritime and supplementary services

6.1 Maritime services available via INMARSAT

See Annexes A and B/E.216.

6.2 Supplementary services

For supplementary services offered by Standard B, the subscriber access and control procedures should be as for equivalent services of the ISDN.

Appendix I

INMARSAT Standard-B mobile-satellite system description

(This appendix does not form an integral part of this Recommendation)

I.1 Introduction

I.1.1 The INMARSAT Standard-B system provides a wide range of public correspondence and distress services between maritime and shore-based users. Links to and from ships are established via the INMARSAT space segment, which provides quasi-global coverage, and the associated ground segment which is provided at the discretion of INMARSAT Signatories with connections to the terrestrial networks including possibly the Integrated Services Digital Network (ISDN). The applications of the Standard-B system include telephony, facsimile, telex and data services which are carried by means of digital satellite channels.

I.1.2 The major elements of the baseline Standard-B system as shown in Figure I.1 are as follows:

- a) *INMARSAT space segment*, in particular the satellite communications transponders and associated frequency bands assigned by the International Telecommunication Union (ITU) and used by INMARSAT for the Standard-B system;
- b) *Standard-B ship earth stations (SES)*, which are designed, manufactured, type-approved, commissioned and operated in accordance with the relevant INMARSAT technical requirement procedures, and which interface with the space segment at L-band (1.5/1.6 GHz) for communications with coast earth stations;
- c) *INMARSAT coast earth stations (CES)*, which operate in accordance with INMARSAT technical requirements, and which interface with the space segment at C-band (4/6 GHz) and L-band, and with the terrestrial networks for communications with SESs;
- d) *INMARSAT network coordination stations (NCS)*, located at designated earth stations, which interface with the space segment at C-band and L-band for the purpose of signalling with SESs and CESs, and for overall network control and monitoring functions, in accordance with INMARSAT technical requirements.

I.1.3 The functions of these four system elements are combined to form the following major Standard-B sub-systems:

- a) *Communications sub-system*, providing the demand-assigned digital satellite communications links between SESs and CESs, with extensions into the terrestrial networks;
- b) *Access control and signalling sub-system*, providing the automatic satellite signalling links between SESs, CESs and NCSs.

I.1.4 The Standard-B system is made up of independent communication networks for each Satellite Ocean Region, each network comprising an operational satellite and associated ground control facilities, ship earth stations (SES) and coast earth stations (CES) operating within that region, and a network coordination station (NCS) which provides overall network management functions.

I.2 Channel configurations

I.2.1 Functional channel configuration

The satellite channels used for communication services and signalling in the Standard-B system are as follows and summarized in Table I.1:

- a) *Voice channel* – Single-channel-per-carrier (SCPC) digital voice channel supporting a voice coding rate of 16 kbit/s with Adaptive Predictive Coding (APC), used in both the forward (shore-to-ship) and return (ship-to-shore) directions. The channels in the forward and return directions are denoted by CESV and SESV, respectively. The use of the channel is controlled by assignment and release signalling at the start and end of each call. Voice activation and power control is implemented on forward carriers. These channels also support voice-band data (including facsimile) up to 2400 bit/s information rate and sub-band signalling (VSUB).

- b) *SCPC data channel* – SCPC digital data channel supporting an information rate of 9.6 kbit/s, used in both forward and return directions. The channels in the forward and return directions are denoted by CESD and SESD respectively. The use of the channel is controlled by assignment and release signalling at the start and end of each call. These channels also support Group-3 facsimile and sub-band signalling (DSUB).
- c) *CES assignment (CESA) channel* – Time-division multiplex (TDM) channel, used in the forward direction to carry CES signalling messages to SESs, including channel assignments for calls which use TDM/TDMA communication channels (telex and low speed data) and appropriate call failure indication messages. The transmission is continuous from each CES in the satellite network.
- d) *CES telex (CEST) channel* – Time-division multiplex (TDM) channel, used in the forward direction to carry telex messages (ITA2 alphabet) from shore-to-ships. The transmission is continuous from each CES in the satellite network.
- e) *CES low speed data (CESDL) channel* – Time-division multiplex (TDM) channel, used in the forward direction to carry low speed data (IA5 alphabet) in an asynchronous mode at information rates up to 300 bit/s. The transmission is continuous from each CES in the satellite network.
- f) *CES interstation (CESI) channel* – Time-division multiplex (TDM) channel used in the C-to-L (forward) direction from each CES to carry signalling information from the CES to the NCS in the satellite network. The transmission is continuous from each CES in the satellite network.
- g) *NCS common (NCSC) channel* – Time-division multiplex (TDM) channel, used in the forward direction to carry NCS signalling messages including call announcements, network status information (Bulletin Board), downloading group IDs and selective clearing. This channel transmits Bulletin Board messages in all slots in which no other signalling message is required to be transmitted. The transmission is continuous from the NCS serving each satellite network.
- h) *NCS assignments (NCSA) channel* – Time-division multiplex (TDM) channel, used in the forward direction to carry channel assignment messages to SESs for calls which use SCPC communications channels (voice, Group-3 facsimile and data). The transmission is continuous from the NCS serving each satellite network.
- i) *NCS spot-beam (NCSS) channel* – Time-division multiplex (TDM) channel, transmitted in the forward direction (one frequency per spot beam) to enable SESs to identify their spot-beam locations. The transmission is continuous from the NCS serving each satellite network.
- j) *NCS interstation (NCSI) channel* – Time-division multiplex (TDM) channel, used in the C-to-L (forward) direction to carry signalling information from the NCS to each CES in the satellite network. The transmission is continuous from each NCS in the satellite network.
- k) *SES telex (SEST) channel* – Time-division multiple access (TDMA) channel, used in the return direction to carry telex (ITA2). The transmission from each SES is in burst mode.
- l) *SES low speed data (SESDL) channel* – Time-division multiple access (TDMA) channel, used in the return direction to carry data (IA5) in an asynchronous mode at information rates up to 300 bit/s. The transmission from each SES is in burst mode.
- m) *SES request (SESRO) channel* – Random access (ALOHA) channel used in the return direction to carry SES signalling information, specifically the request messages which initiate a ship-originated call and the acknowledgement messages for shore-originated simplex calls. This channel is also received by the NCS for distress back-up purposes.
- n) *SES response (SESRP) channel* – TDMA channel used in the return direction to carry SES signalling information to CESs, specifically the response information required for a shore-originated call and for the acknowledgement of SES group ID downloading messages.

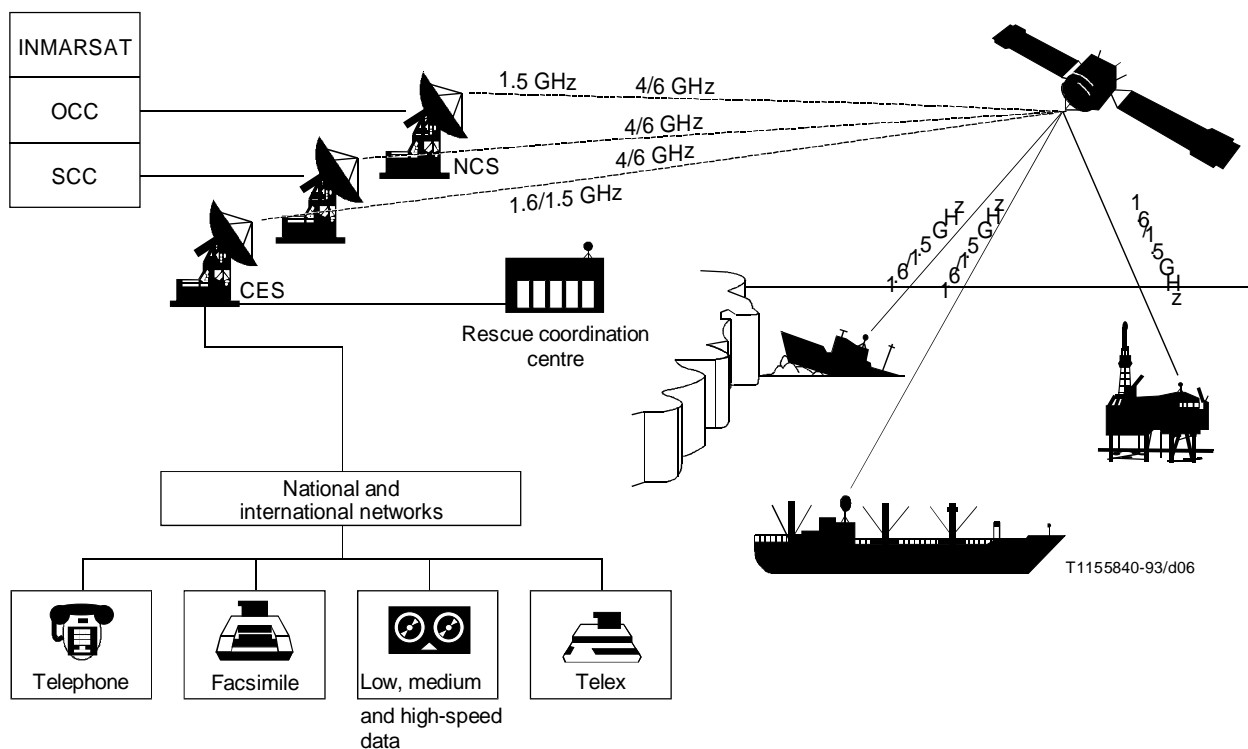

FIGURE I.1/Q.1111
Standard-B network configuration

I.2.2 Physical channel configuration

Initially, whilst traffic demand permits, functional channels having the same format are combined and transmitted as a single physical channel. Later, as the system develops, separate physical channels may be required.

The resultant physical channels, as shown in Figure I.2, in the initial implementation are:

- a) Voice channels.
- b) SCPC data channels.
- c) CES TDM channel (combination of CESA, CEST, CESDL, CESI).
- d) NCS TDM channel (combination of NCSC, NCSI, NCSA).
- e) SES TDMA channel (combination of SEST, SESDL).
- f) SESRQ channel.
- g) SESRP channel.

The NCSS channels will be required when a spot beam satellite is introduced.

I.2.3 Forward error correction coding

All Standard-B channel types use Forward Error Correction (FEC) coding consisting of a convolution encoder of constraint length $k = 7$ and an 8-level soft decision Viterbi decoder. The FEC coding rate is either $3/4$ or $1/2$. The rate $3/4$ code is derived by puncturing the $1/2$, $k = 7$ convolution code.

I.2.4 Information scrambling

A PN scrambler with a 15-stage generator register is used for scrambling before FEC encoding. The concept of a PN scrambler is explained in CCIR Report 384, Annex III, Section 3, Method 1. The scrambler and descrambler configurations are exactly as shown in the CCIR report.

TABLE I.1/Q.1111

**Standard-B communications of signalling channels
(Description of functional channels)**

Functional channel type	Origin (Note 1)	Destination (Note 1)	Characteristics	L-band satellite beam (Note 2)
1 Voice channel a) SESV b) CESV c) VSUB	SES(M) CES(M)	CES(M) SES(M)	Voice, SCPC Voice, SCPC (both 16 kbit/s information rate) Sub-band signalling in voice channel (VSUB)	G and S G and S G and S
2 SCPC data channel a) SESD b) CESD c) DSUB	SES(O) CES(O)	CES(O) SES(O)	SCPC data SCPC data (both 9.6 kbit/s information rate) Sub-band signalling in SCPC data channel (DSUB)	G and S D and S G and S
3 CES TDM channel a) CESA b) CEST c) CESDL d) CESI	CES(M) CES(M) CES(O) CES(M)	SES(M) SES(O) SES(O) NCS(M)	Signalling Telex Low speed data up to 300 bit/s Interstation signalling	G G and S G and S G
4 SES TDMA channel a) SEST b) SESDL	SES(O) SES(O)	CES(M) CES(M)	Telex Low speed data up to 300 bit/s	G and S G and S
5 SES request channel SESRQ	SES(M)	CES(M)	SES requests, ALOHA	G
6 SES response channel SESRP	SES(M)	NCS(M)	SES response TDMA	G
7 NCS TDM channel a) NCSC b) NCSA c) NCSI	NCS(M) NCS(M) NCS(M)	SES(M) SES(M) SES(M)	Common channel Assignment channel Interstation signalling channel	G G G
8 Spot/beam identification channel NCSS	NCS(M)	SES(M)	Spot-beam identification	S
<p>NOTES</p> <p>1 M and O denote mandatory and optional capabilities respectively.</p> <p>2 G and S denote global and spot beams respectively.</p> <p>3 INMARSAT-B SESs have capability for operation with spot-beam signalling channels though nominally INMARSAT-B signalling channels will be in global beam.</p>				

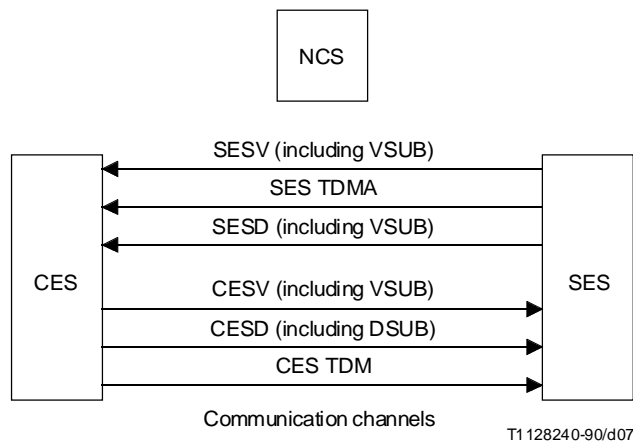
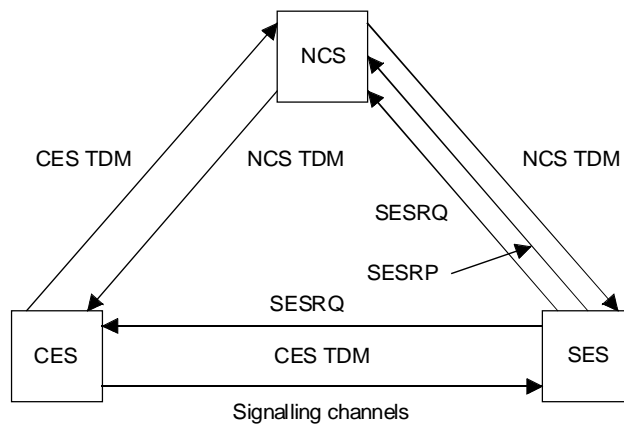

T1 128240-90/d07

FIGURE 1.2/Q.1111

Standard-B initial physical channel configuration

I.2.5 Power control

All SCPC forward channels employ power control to conserve satellite L-band power. The power control scheme is open loop, and depends on knowledge, at the CES, of the SES antenna elevation angle to the satellite. This information is used to adjust the output power setting of the CES, according to a predetermined algorithm.

I.3 Access control and signalling sub-system

I.3.1 The Standard-B system provides efficient channel access operation based on demand assignment, and enables power control to be employed on forward SCPC carriers for efficient satellite power utilization. Ship earth station operational compatibility with current and planned space segment configurations is also provided for, including the ability to operate with future spot-beam satellites.

I.3.2 The NCS provides a wide range of system monitoring functions, so as to facilitate a change in carrier frequency assignments in the event of interference on signalling channels. It also manages SCPC frequency pools for SCPC channel assignments and transmits the associated signalling messages to the SES and CES to enable them to proceed with the call set-up.

I.3.3 The channel assignment methods in the Standard-B system are based on centralized control at the NCS for services using SCPC communication channels (telephony and SCPC data) and decentralized (distributed) control at CESs for services using TDM/TDMA communication channels (telegraphy and low speed data). The transmission of assignment information to an SES is always on a signalling channel originating from the same earth station (NCS or CES) as that which performs the channel assignment function.

I.3.4 For signalling purposes and for TDM/TDMA traffic, each CES is allotted a minimum of one forward CES TDM channel frequency and one return SES TDMA channel frequency, both for normal operation and for use in the event of NCS failure. Additionally, and in order to provide SCPC services in the event of NCS failure, CESs may optionally be equipped with facilities for SCPC channel assignment and for transmission of the associated signalling functions (CES Stand-Alone Mode). Each CES with such stand-alone capabilities will be allotted a set of SCPC carrier frequencies by INMARSAT; when the NCS returns to operational service, these carrier frequencies are reallocated to the NCS pool.

I.3.5 For ship-originated SCPC calls, the SES request message is received by the addressed CES. The CES sends a request to the NCS for channel assignment, and the NCS assigns a channel in the appropriate satellite spot beam, if available, or a global-beam channel is assigned if an appropriate spot-beam frequency is not available. The NCS then transmits the channel assignment information to both the CES and the SES.

I.3.6 For ship-originated TDM/TDMA calls, the SES request message is received by the addressed CES which then performs the assignment function and transmits the assignment message to the SES (and NCS).

I.3.7 For shore-originated SCPC calls, the CES requests the NCS to transmit a call announcement message to the required SES which then responds to the NCS. The NCS assigns a channel in the appropriate spot beam, if available, or a global-beam channel is assigned if an appropriate spot-beam frequency is not available. The NCS then transmits the channel assignment information to both the CES and the SES.

I.3.8 For shore-originated TDM/TDMA calls, the CES requests the NCS to transmit a call announcement to the SES which then responds to the NCS. The NCS relays the SES response to the CES, which then performs the assignment function and transmits the assignment message to the SES (and NCS).

I.3.9 A two-level precedence system of channel assignment is implemented depending on the priority level of the call, as indicated by the calling shore-side or ship-borne user. The priorities signalled within the Standard-B system are: 3 (Distress), 2 (Urgency), 1 (Safety) and 0 (Routine). Call requests are sorted at the CES into categories corresponding to priority. For both shore-originated and ship-originated calls, only those with Priority 3 (Distress) are processed on a preferential basis by the CES. Priorities other than 3 (i.e. non-Distress calls) are processed on a "first come, first served" basis. Each call is assigned a channel if a CES channel unit and (depending on the service required) either an SCPC frequency (from the NCS pool) or a TDM/TDMA time-slot (from the CES) are available.

I.3.10 When operating to spot-beam satellites the SES performs spot-beam identification by measuring the channel bit error rate and/or relative signal strength of forward signalling NCSS carriers transmitted through each spot-beam transponder. The carrier frequencies and spot-beam identities are advised to SESs via the NCSC channel Bulletin Board to allow identification of the appropriate spot beam when establishing calls.

I.3.11 The signalling system is based on the use of out-of-band, sub-band and in-band signalling depending on the particular access control and communication channel requirements. Out-of-band and sub-band signalling use fixed length signal units which have a specified function according to the required message type. The definitions of these signal units contain sufficient spare capacity so as to enable future services and facilities to be readily implemented as required at SESs and CESs.

I.4 Communications sub-system

I.4.1 Modulation and coding

Standard-B satellite channels use digital modulation to efficiently utilize satellite power and bandwidth, with forward error correction (FEC).

The basic modulation techniques are filtered offset-quadrature phase-shift keying (O-QPSK) and filtered differentially encoded binary phase-shift keying (BPSK). Convolutional coding at either rate 1/2 or rate 3/4 (using punctured coding) is used with the former, and convolutional coding at rate 1/2 with the latter.

Adaptive predictive coding (APC) at 16 kbit/s is the voice coding technique adopted, at 24 kbit/s channel rate, with O-QPSK modulation and rate 3/4 FEC. As a SES and CES option, 9.6 kbit/s APC with 15 kbit/s channel rate, with rate-3/4 FEC, may be provided in addition.

The APC algorithm is capable of supporting voice-band data and facsimile at rates of up to 2400 bit/s with 16 kbit/s APC, and up to 600 bit/s with 9.6 kbit/s APC.

Telex and optional 300 bit/s data (e.g. for connection to data base and electronic mail systems) are provided in the forward link (CEST and CESDL channels) at 6 kbit/s channel rate, with BPSK modulation and rate 1/2 FEC. In the return direction these services are provided at 24 kbit/s channel rate, with O-QPSK modulation and rate 1/2 FEC.

Other optional data services include data (up to 16 kbit/s and 9.6 kbit/s information rate) and facsimile (up to 9.6 kbit/s information rate) which are provided by means of digital data satellite channels at 24 kbit/s channel rate with O-QPSK and rate 1/2 FEC, which can at the option of the CES Operator be interfaced with the fixed networks including the public switched telephone network (PSTN), public switched data networks (e.g. PSPDN for packet data) or private wires as appropriate.

I.4.2 Channel access methods

The Standard-B system makes use of channel access methods appropriate to the communications services offered, in order to maximize efficiency and to minimize call connection delays. Access methods are as follows:

- a) telephony: single-channel-per-carrier (SCPC) in frequency-division multiple access (FDMA);
- b) telex and 300 bit/s Data: time-division multiplex (TDM/FDMA) in the forward direction, and time-division multiple access (TDMA/FDMA) in the return direction. Each CES is pre-assigned one or more forward TDM carrier frequencies; and
- c) 16 kbit/s and 9.6 kbit/s Data, and Facsimile: SCPC/FDMA.

I.5 Link layer formats and protocols

I.5.1 General

All signalling messages are formatted into uniform signal units of 96 bits (12 octets). This signal unit (SU) size allows for the most common transaction to be carried out with only one signal unit with a minimum of spare unused capacity. The use of these signal units applies to signalling transactions on the sub-band signalling channel of the SCPC voice and data channels as well as out-of-band signalling on all other channels.

I.5.2 Basic signal unit concepts

A signalling message that can be accommodated in a single signal unit is formatted into a "Lone Signal Unit" (LSU). Longer messages are formatted into more than one Signal Unit (SU), of which the first is an "Initial Signal Unit" (ISU) followed by one or more "Subsequent Signal Units" (SSU).

Each signalling SU includes 16 check bits (the last two octets) for error detection, these being calculated from the first 10 octets of the SU using the following generator polynomial (see 2.2.7/X.25): $x^{16} + x^{12} + x^5 + 1$.

The undetected error rate for these signal units, under nominal worst case conditions is typically less than one in 10^{10} SUs.

On reception the check bits for each SU are calculated, and if there is a mismatch with the received check bits the SU is discarded. Protocol recovery from lost and corrupted SUs is handled by the relevant signalling logic procedures.

For the NCS and CES signalling channels (except NCSC channel) and all sub-band channels, if no other SU or information is to be sent when the channel becomes available, a fill-in SU is sent. In such cases, for the NCSC channel Bulletin Board SUs are sent. For the SES signalling channels each SU is formatted into its own burst; SES sub-band channels always contain signalling messages. If no other signalling message need be sent, the “SES Connect” message is sent in this sub-band channel.

I.6 Telephone services

I.6.1 General

Telephone services are provided using a pair of voice (V) channels, assigned from a common pool held by the NCS. The primary function of the NCS is to make V-channel assignments in response to requests from CES on a call by call basis.

I.6.2 Ship-originated duplex call set-up

I.6.2.1 The sequence for ship-originated duplex telephone call set-up is shown in Figure I.3.

I.6.2.2 The following paragraphs describe the various steps in the ship-originated call set-up sequence for non-distress calls (see I.6.6 for distress call set-up procedures).

I.6.2.3 With the exception of priority 3 (distress) calls, the CES sets up the call only if the following conditions are satisfied:

- the requested service capability exists at the CES;
- a channel unit compatible with the requested service parameters is available at the CES; and
- SES is authorized for the requested service.

I.6.2.4 The SES receives from the local terminal the complete number to be called prior to starting the request process.

I.6.2.5 The information regarding the type/rate of voice coding (i.e. 16 kbit/s and, optionally, 9.6 kbit/s) with which each Standard-B CES is equipped will be signalled to the SESs in the “CES capability advice” message (1BH) as part of the Bulletin Board. For ship-originated calls, the SES uses this “CES voice coding” information (stored in its Network Storage Register) to enable the ship-board user/SES to choose the relevant voice coding type. However it is to be noted that provision of 16 kbit/s voice is mandatory at both CES and SES for Standard-B system and that distress (priority 3) telephony calls have to use only this voice coding rate. Appropriate values (corresponding to the chosen voice coding type) for “service nature”, “service type” and “channel parameter” fields will be used in the “access request” message (03H) by the SES to indicate to the CES the voice coding rate being requested for any particular call.

I.6.2.6 The SES sends an “access request” message (normally 03H, but 04H for distress) to the CES using the SESRQ channel, including SES antenna elevation angle zone, azimuth angle zone and spot-beam ID information. If the SES is not in its local (CES) busy list and if the conditions in I.6.2.3 are satisfied, the CES sends a “request for channel assignment” message (7FH) over the CESI channel to the NCS after adding the SES to its local busy list. On the other hand if the SES is already in its local busy list, the CES removes it and establishes a new call. If any of the conditions in I.6.2.3 are not satisfied, the procedure described in I.6.2.9 is followed.

I.6.2.7 Upon receipt of the “request for channel assignment” message (7FH) from the CES, if a frequency (in the appropriate spot beam or global beam) is available, the NCS sends a “channel assignment” message (7EH) to the CES over the NCSI channel and a “channel assignment” message (06H) to the SES over the NCSA channel and enters the SES (and the assigned frequencies) in its Status Table (busy list). If a channel frequency in the requested spot beam is available, then the NCS assigns it; otherwise a global-beam frequency is assigned. If neither spot-beam nor global-beam frequency is available, the NCS sends the “call failure indication” message (79H) to the CES over the NCSI channel and the “call failure indication” message (05H) to the SES over the NCSA channel with appropriate “cause indication” information.

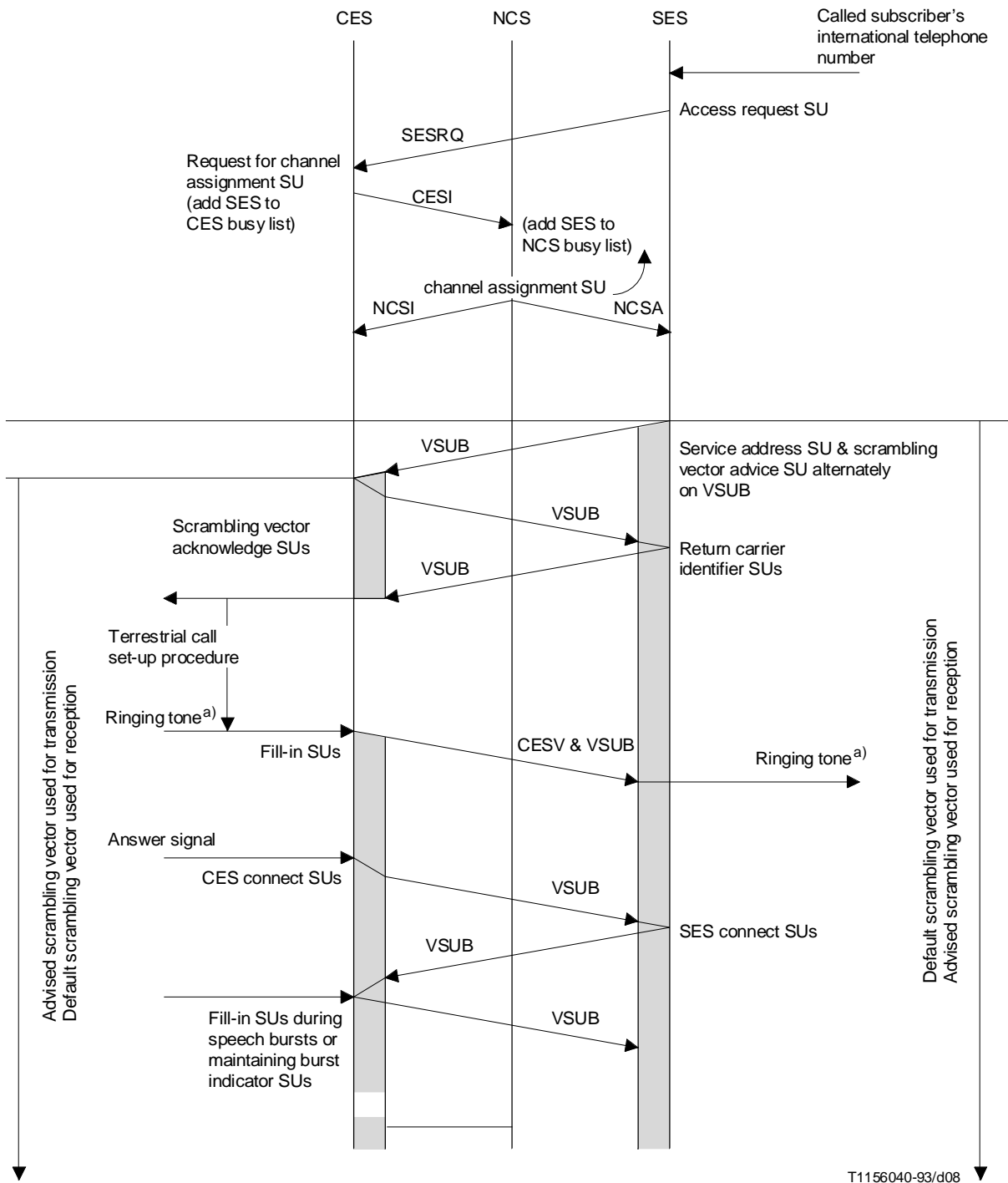

T1156040-93/d08

Denotes presence of carrier

^{a)} If busy tone or network congestion tone is received instead of ringing tone, clearing sequence by the calling party will follow.

FIGURE I.3/Q.1111
Standard-B ship to shore telephone call set-up sequence

I.6.2.8 After tuning to the assigned communication channels, the SES sends the called party address via the sub-band channel using the “service address” messages (08H and 09H) together with the “scrambling vector” message (0DH). To provide secure transfer of the address and scrambling vector without the protocol complication of a repeat request arrangement, the SES sends the signalling messages 08H, 09H, 0DH, 08H, 09H, 0DH in sequential order continuously until a “scrambling vector acknowledge” message (15H) is received from the CES via the sub-band channel, or a time-out occurs (whichever is earlier).

I.6.2.9 If any of the requirements in I.6.2.3 are not fulfilled, the call cannot proceed and the CES sends a “call failure indication” message (79H) over the CESI to the NCS and the NCS, upon receipt of this message, sends a “call failure indication” message (05H) to the SES over the NCSA channel. These two “call failure indication” messages (79H and 05H) contain identical appropriate “cause indication” information.

I.6.3 Clearing for ship-originated calls

I.6.3.1 The sequences for both ship-initiated and shore-initiated clearing of ship-originated calls are given in Figure I.4.

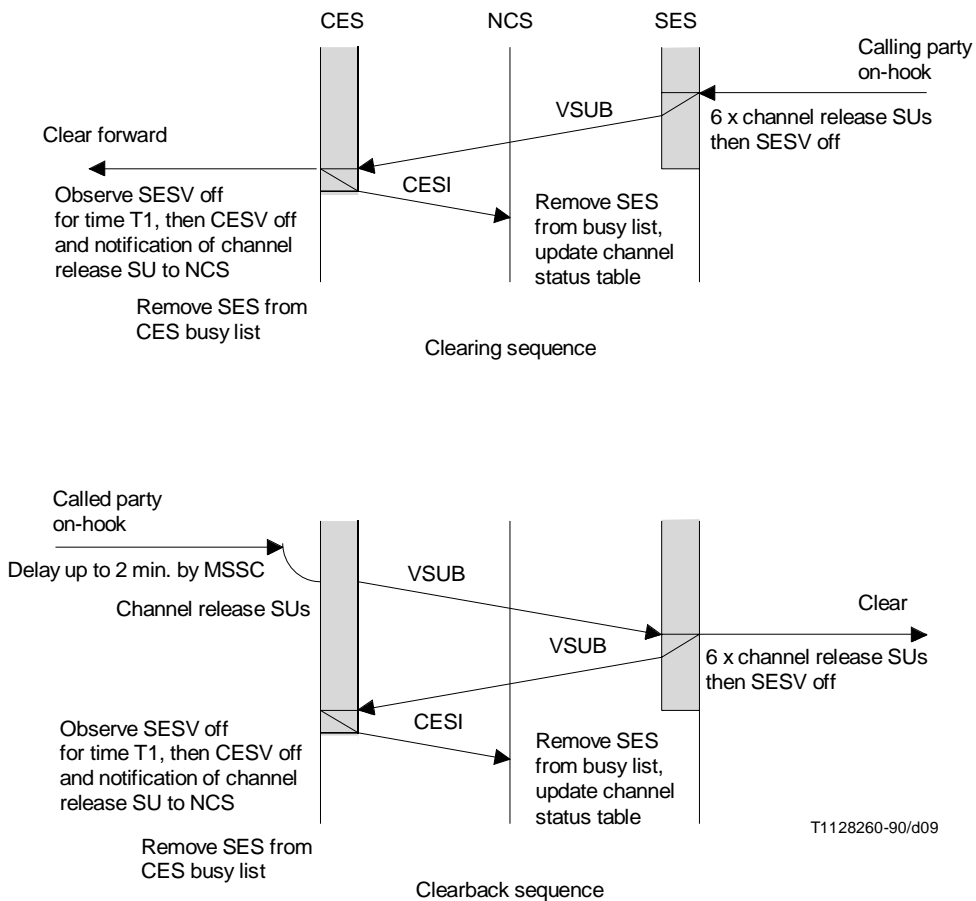

FIGURE I.4/Q.1111
Standard-B clearing sequence for ship originated telephone calls

I.6.3.2 Upon receipt of an on-hook signal (or any other clearing signal) the SES sends six “channel release” messages (0AH) in the sub-band channel with the appropriate “cause indication” value and then turns off its SESV channel. If, after receiving one of these messages, the CES observes the SESV to be absent for time T1, the CES turns off its own CESV channel; sends the “notification of channel release” message (7CH) to the NCS (with appropriate “cause indication” value and with the “release/blockage” field set to “0”); removes the SES and the frequencies from its busy list and frees the channel unit. On receipt of this 7CH message, the NCS releases the associated frequencies to its common pool and removes the SES from its status table (busy list).

I.6.3.3 In the abnormal event of the SESV channel not being sensed to be off (for a minimum time T1) within a time period T2 starting from the receipt of the “channel release” message (0AH), the CES follows the CES-initiated clearing procedure by continuously sending “channel release” messages (0AH) in the sub-band channel (with the appropriate “cause indication” value) until either:

- i) it receives at least one “channel release” message (0AH) from the SES in the sub-band followed by sending of SESV channel off (for a minimum time T1); or
- ii) the expiry of timer T3 without sensing the SESV channel off.

I.6.3.4 In case i), the CES stops the timer T3; turns off its CESV channel and then follows the rest of the procedure as described in I.6.3.2. The NCS also follows the procedure described in the same subclause.

I.6.3.5 In case ii), the CES turns off its CESV channel and waits for time T4 (for the “long-term interruption” timer in the SES to expire) to determine whether the SES carrier has stopped. If the SES carrier stops within this time, the CES turns off its CESV channel and then (CES and NCS) follows the rest of the procedure as described in I.6.3.2. However, if the SES carrier has not stopped even after the expiry of timer T4, the CES puts off its forward carrier and sends the “notification of channel release” message (7CH) to the NCS (with the appropriate “cause indication” value and with the “release/blockage” field set to “1”) so as to inform the NCS of the abnormal functioning of the SES and the “blockage” of the return channel frequency. The CES then removes the SES and the channel frequencies from its busy list and also frees the associated channel unit as per the procedure in I.6.3.2. The NCS, on receipt of the 7CH message with “blockage” indication, marks the return channel frequency as “blocked” but removes the SES from its status table (busy list).

I.6.3.6 It is to be noted that a malfunctioning (failed to clear) SES is not marked as “blocked” (at both CES and NCS) so as to allow subsequent call attempts to be made from/to that SES. Only the return channel frequency which has failed to clear is marked as “blocked” at the NCS so as to prevent its assignment for subsequent calls. However both the CES and the NCS will keep a record of malfunctioning SESs and “blocked” frequencies for abnormal clearing (e.g. by manual action) and channel status information transfer.

I.6.3.7 Apart from the abnormality which is considered in I.6.3.3, another type (of abnormality) could occur if the CES senses the SESV channel to be off for more than time T5 without receiving a “channel release” message (0AH) from the SES. In this case the CES starts to send the “channel release” messages (0AH) in the sub-band of the CESV channel and follows the rest of the CES-initiated clearing procedure described in I.6.3.3 to I.6.3.6.

I.6.3.8 For shore-originated clearing (clear-back sequence), upon receipt of an on-hook signal from the terrestrial network, the Maritime Satellite Switching Centre in the terrestrial network may wait for up to 2 minutes before sending the clearing signal to the CES. The CES then follows the CES-initiated clearing procedure by starting to send the “channel release” messages (0AH) continuously in the sub-band of the CESV channel. This CES-initiated procedure is given in I.6.3.3 to I.6.3.7 (which deal with abnormal events in the clearing procedure).

I.6.3.9 If the answer signal is not received by CES within 90 seconds after initiating the terrestrial call set-up procedure, the CES initiates the clearing process by sending the “channel release” message in the sub-band channel (with the indication that the user has not responded) and following the CES-initiated clearing procedures described above.

I.6.4 Shore-originated duplex telephone call set-up

I.6.4.1 The sequence for shore-originated duplex telephone call set-up is shown in Figure I.5.

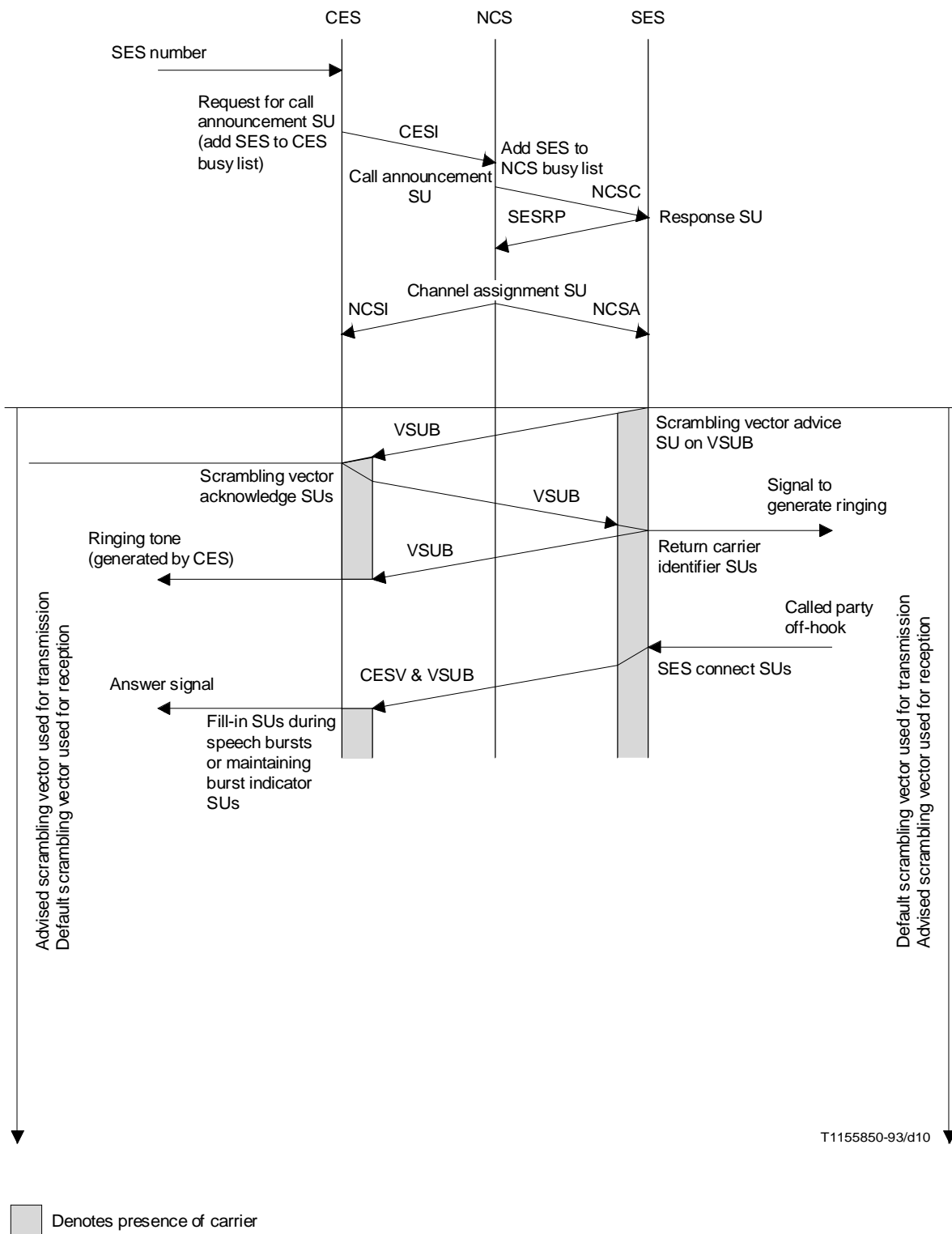

FIGURE I.5/Q.1111
Standard-B shore originated telephone call set-up sequence

I.6.4.2 The following paragraphs describe the various steps in the shore- originated call set-up sequence for non-distress calls (see I.6.6 for distress call set-up procedures).

I.6.4.3 With the exception of the priority 3 (distress) calls, the CES sets up the call only if the following conditions are satisfied:

- the requested service capability exists at the CES;
- a channel unit compatible with the requested service parameters is available at the CES;
- SES is authorized for the requested service; and
- SES is not in the CES local busy list.

I.6.4.4 The Maritime Satellite Switching Centre connected to the CES receives and analyses the INMARSAT mobile international number dialled by the shore- subscriber, where the “T”-digit is used to route the call to the appropriate CES equipment serving the Standard-B system. The CES analyses the digits which follow the “T”-digit to check the SES authorization status before proceeding with the call set-up sequence.

I.6.4.5 If the conditions mentioned in I.6.4.3 are fulfilled, the CES enters the SES in the local busy list and sends a “request for call announcement” message (73H) to the NCS via the CESI channel; otherwise, an appropriate call failure signal is sent to the shore-side subscriber. Provided that the SES is not marked as “busy” in the SES status table at the NCS, the NCS sends the “call announcement” message (01H) to the SES via the NCSC channel. If the SES is marked as busy, a “call failure indication” message (79H), with the appropriate “cause indication value”, is sent to the CES over the NCSI channel, upon receipt of which the CES informs the shore-side party of the failure of the call.

I.6.4.6 The SES transmits a “response” message (02H) on the appropriate SESRP channel to the NCS, including SES antenna elevation angle and azimuth angle zones and spot-beam ID information. There is not SES “response” message if the SES is not operational, or if it is not in the NCS's ocean region at the time. If the SES is present but unable to accept the call, the SES transmits a “call failure indication” message (05H), with the appropriate “cause indication” value, to the NCS on the appropriate SESRP channel.

I.6.4.7 Upon receipt of a “response” message from the SES accepting the call, the NCS assigns a channel, if available, from its pool and transmits the “channel assignment” message (06H) to the SES over the NCSA channel and the “channel assignment” message (7EH) to the CES over the NCSI channel. The SES is then added to the status table at the NCS. If an appropriate spot-beam frequency is not available, the NCS assigns a global-beam channel. If no frequencies are available (either in the spot beam or global beam), or if the NCS receives either no response or a “call failure indication” message (05H) from the SES, the NCS sends a “call failure indication” message (79H), with the appropriate “cause indication” value, over the NCSI channel to the CES, which then informs the calling shore-side party of the failure of the call.

I.6.4.8 At the SES, the decision as to whether the call can go ahead is based on the current availability of terminal equipment appropriate to the service type specified in the NCSC “call announcement” message (01H).

I.6.4.9 For priority 3 calls, the provisions of I.6.6 apply.

I.6.5 Clearing for shore-originated calls

I.6.5.1 The sequences for both ship-initiated clearing and shore-initiated clearing of shore-originated calls are given in Figure I.6.

I.6.5.2 For shore-originated clearing, upon receipt of the clearing signal from the Maritime Satellite Switching Centre, the CES sends a sequence of “channel release” messages (0AH), with the appropriate “cause indication” value, to the SES on the forward sub-band (VSUB) channel. On receipt of one of these “channel release” messages (0AH), the SES sends six “channel release” messages (0AH) on the return sub-band (VSUB) channel (with appropriate “cause indication” value) and removes its SESV channel. When the CES detects that the SESV channel has been removed, the CES turns off its CESV channel; sends the “notification of channel release” message (7CH) to the NCS over the CESI channel (with the appropriate “cause indication” value and with the “release/blockage” field set to “0”); removes the SES and the associated frequencies from the local busy list and frees the channel unit. On receipt of this 7CH message, the NCS releases the frequencies to its common pool and removes the SES from its status table.

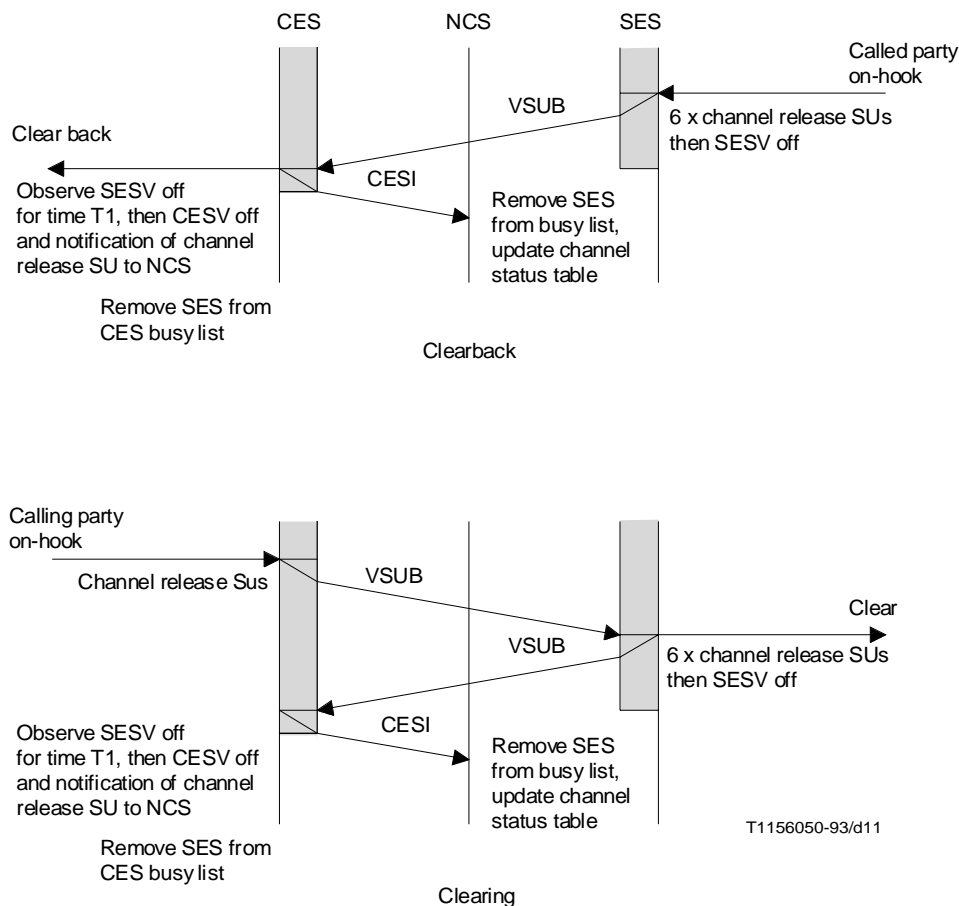

FIGURE I.6/Q.1111

Standard-B clearing sequence for shore-originated telephone calls

I.6.5.3 For SES-initiated clearing of shore-originated calls (clear-back sequence), similar procedures as for the clearing of ship-originated calls (which are described in I.6.3.2) are followed.

I.6.5.4 In the case of abnormal events in the clearing sequence, the procedures described in I.6.3.3 to I.6.3.7 are followed.

I.6.5.5 If the off-hook signal from the called ship board party is not received by the SES within 90 seconds after sending the signal for ringing, the SES initiates the clearing process by sending the “channel release” message (with the indication that the user has not responded) six times in the sub-band channel and following the clearing procedures described above.

I.6.6 Priority 3 (Distress) telephony calls (duplex)

I.6.6.1 The duplex call set-up and clearing procedures for Priority 3 (Distress) calls are the same as those for other priorities (0, 1 and 2) as described in I.6.2 through I.6.5, with the following exceptions:

- the SES access request message (type 04H) contains SES antenna elevation and azimuth angle information;
- the CES does not check the SES authorization status;
- the CES does not check for service availability (as the service is always for 16 kbit/s duplex telephony);

- the CES pre-empts a channel unit (which itself is not serving another distress call) if none is available to serve the distress call;
- the call is processed even if the service address is missing or is incomplete;
- the NCS maintains in reserve a pair of global-beam frequencies in order to service distress calls; and
- for ship originated distress calls, if the “called” CES does not respond the NCS establishes the communications via the back-up CES. Inherently there is no such NCS distress back-up function for shore-originated distress calls.

I.6.6.2 The SES maintains in its memory the ID of a particular CES for distress (priority 3) calls, selected previously by the SES operator and modified as necessary depending on current Ocean Region and CES status as contained in the SES Network Status Record derived from the Bulletin Board.

I.6.7 Supervisory signalling

I.6.7.1 After channel set-up for telephone calls, all subsequent supervisory functions are normally performed by means of sub-band signalling (VSUB).

I.6.7.2 Sub-band signalling within the telephone channel frame is used for connect/clearing signals, identification of SES transmissions (as an aid to locating a malfunctioning SES in the event of interference), and to provide additional signalling capacity for potential future use in connecting the channel with terrestrial ISDN networks.

I.6.7.3 Terrestrial network audible tones (ringing, busy, unobtainable, etc.) are passed to the SES in-band over the voice channel for ship-originated calls. In the case of shore-originated calls, the MSSC generates the appropriate audible tone back into the terrestrial network to the shore subscriber.

I.6.8 Voice coding

Adaptive predictive coding (APC) at 16 kbit/s and optionally at 9.6 kbit/s, is the voice coding method for the Standard-B system.

I.6.9 Indication of call duration

For ship-originated telephone calls, the SES can derive a close estimate of the chargeable call duration information using the appropriate sub-band signals. The call duration may be obtained by the SES by measuring the elapsed time between the receipt of connect signal and call-clear signal. Both these messages are transmitted by the CES in the sub-band channel for shore-originated clearing. Using the call duration, the SES can derive an estimate of the charge for the call, display it to the user and/or record this information at the ship.