

International Telecommunication Union

ITU-T

TELECOMMUNICATION
STANDARDIZATION SECTOR
OF ITU

Q.1742.6

(08/2007)

SERIES Q: SWITCHING AND SIGNALLING

Signalling requirements and protocols for IMT-2000

**IMT-2000 references (approved as of
31 December 2006) to ANSI-41 evolved core
network with cdma2000 access network**

ITU-T Recommendation Q.1742.6



ITU-T Q-SERIES RECOMMENDATIONS
SWITCHING AND SIGNALLING

SIGNALLING IN THE INTERNATIONAL MANUAL SERVICE	Q.1–Q.3
INTERNATIONAL AUTOMATIC AND SEMI-AUTOMATIC WORKING	Q.4–Q.59
FUNCTIONS AND INFORMATION FLOWS FOR SERVICES IN THE ISDN	Q.60–Q.99
CLAUSES APPLICABLE TO ITU-T STANDARD SYSTEMS	Q.100–Q.119
SPECIFICATIONS OF SIGNALLING SYSTEMS No. 4, 5, 6, R1 AND R2	Q.120–Q.499
DIGITAL EXCHANGES	Q.500–Q.599
INTERWORKING OF SIGNALLING SYSTEMS	Q.600–Q.699
SPECIFICATIONS OF SIGNALLING SYSTEM No. 7	Q.700–Q.799
Q3 INTERFACE	Q.800–Q.849
DIGITAL SUBSCRIBER SIGNALLING SYSTEM No. 1	Q.850–Q.999
PUBLIC LAND MOBILE NETWORK	Q.1000–Q.1099
INTERWORKING WITH SATELLITE MOBILE SYSTEMS	Q.1100–Q.1199
INTELLIGENT NETWORK	Q.1200–Q.1699
SIGNALLING REQUIREMENTS AND PROTOCOLS FOR IMT-2000	Q.1700–Q.1799
SPECIFICATIONS OF SIGNALLING RELATED TO BEARER INDEPENDENT CALL CONTROL (BICC)	Q.1900–Q.1999
BROADBAND ISDN	Q.2000–Q.2999
SIGNALLING REQUIREMENTS AND PROTOCOLS FOR THE NGN	Q.3000–Q.3999

For further details, please refer to the list of ITU-T Recommendations.

ITU-T Recommendation Q.1742.6

IMT-2000 references (approved as of 31 December 2006) to ANSI-41 evolved core network with cdma2000 access network

Summary

ITU-T Recommendation Q.1742.6 associates the published core network standards from the regional standards development organizations (SDOs) with those 3GPP2 specifications that were approved as of 31 December 2006 for the IMT-2000 family member "ANSI-41 evolved core network with cdma2000 access network".

3GPP2 specifications that were approved as of 17 July 2001 were associated with the published core network standards from the regional standards development organizations in ITU-T Recommendation Q.1742.1. 3GPP2 specifications that were approved as of 11 July 2002 were associated with the published core network standards from the regional standards development organizations in ITU-T Recommendation Q.1742.2. 3GPP2 specifications that were approved as of 30 June 2003 were associated with the published core network standards from the regional standards development organizations in ITU-T Recommendation Q.1742.3. 3GPP2 specifications that were approved as of 30 June 2004 were associated with the published core network standards from the regional standards development organizations in ITU-T Recommendation Q.1742.4. 3GPP2 specifications that were approved as of 31 December 2005 were associated with the published core network standards from the regional standards development organizations in ITU-T Recommendation Q.1742.5.

3GPP2 specifications that are approved as of 31 December 2007 will be associated with published core network standards in future ITU-T Recommendation Q.1742.7. The radio interface and radio access network and standards from the SDOs for this IMT-2000 family member are associated in ITU-R Recommendation M.1457-6. The associations for other IMT-2000 family members are identified in ITU-T Q.174x-series Recommendation.

This Recommendation combines and associates the regional standards for the core network of this IMT-2000 family member into a global Recommendation.

Source

ITU-T Recommendation Q.1742.6 was approved on 13 August 2007 by ITU-T Study Group 19 (2005-2008) under the ITU-T Recommendation A.8 procedure.

Keywords

ANSI-41, cdma2000, core network, IMT-2000, third generation system.

FOREWORD

The International Telecommunication Union (ITU) is the United Nations specialized agency in the field of telecommunications. The ITU Telecommunication Standardization Sector (ITU-T) is a permanent organ of ITU. ITU-T is responsible for studying technical, operating and tariff questions and issuing Recommendations on them with a view to standardizing telecommunications on a worldwide basis.

The World Telecommunication Standardization Assembly (WTSA), which meets every four years, establishes the topics for study by the ITU-T study groups which, in turn, produce Recommendations on these topics.

The approval of ITU-T Recommendations is covered by the procedure laid down in WTSA Resolution 1.

In some areas of information technology which fall within ITU-T's purview, the necessary standards are prepared on a collaborative basis with ISO and IEC.

NOTE

In this Recommendation, the expression "Administration" is used for conciseness to indicate both a telecommunication administration and a recognized operating agency.

Compliance with this Recommendation is voluntary. However, the Recommendation may contain certain mandatory provisions (to ensure e.g. interoperability or applicability) and compliance with the Recommendation is achieved when all of these mandatory provisions are met. The words "shall" or some other obligatory language such as "must" and the negative equivalents are used to express requirements. The use of such words does not suggest that compliance with the Recommendation is required of any party.

INTELLECTUAL PROPERTY RIGHTS

ITU draws attention to the possibility that the practice or implementation of this Recommendation may involve the use of a claimed Intellectual Property Right. ITU takes no position concerning the evidence, validity or applicability of claimed Intellectual Property Rights, whether asserted by ITU members or others outside of the Recommendation development process.

As of the date of approval of this Recommendation, ITU had not received notice of intellectual property, protected by patents, which may be required to implement this Recommendation. However, implementers are cautioned that this may not represent the latest information and are therefore strongly urged to consult the TSB patent database at <http://www.itu.int/ITU-T/ipr/>.

© ITU 2008

All rights reserved. No part of this publication may be reproduced, by any means whatsoever, without the prior written permission of ITU.

CONTENTS

	Page
1 Scope	1
2 References.....	1
3 Definitions	2
4 Abbreviations and acronyms	5
5 Introduction	9
6 Basic architecture for the ANSI-41 evolved core network with cdma2000 access network family member.....	9
7 Network entities.....	16
7.1 Authentication, authorization and accounting (AAA).....	16
7.2 Authentication centre (AC)	16
7.3 Call data collection point (CDCP).....	16
7.4 Call data generation point (CDGP)	16
7.5 Call data information source (CDIS).....	16
7.6 Call data rating point (CDRP)	17
7.7 Collection function (CF) – [Intercept].....	17
7.8 Coordinate routing database (CRDB)	17
7.9 Customer service centre (CSC)	17
7.10 Delivery function (DF) – [Intercept]	17
7.11 Equipment identity register (EIR)	17
7.12 Home agent (HA)	18
7.13 Home location register (HLR).....	18
7.14 Intelligent peripheral (IP)	18
7.15 Intercept access point (IAP)	18
7.16 Interworking function (IWF).....	18
7.17 Local position determining entity (LPDE)	18
7.18 Managed wireless network entity (MWNE).....	18
7.19 Message centre (MC)	18
7.20 Mobile position centre (MPC).....	18
7.21 Mobile switching centre (MSC)	19
7.22 Number portability database (NPDB)	19
7.23 Over-the-air service provisioning function (OTAF)	19
7.24 Packet data network (PDN).....	19
7.25 Packet data serving node (PDSN)	19
7.26 Position-determining entity (PDE).....	19
7.27 Service control point (SCP).....	19
7.28 Service node (SN).....	19
7.29 Short message entity (SME).....	19
7.30 Visitor location register (VLR)	19

	Page	
7.31	Voice message centre (VMS).....	19
7.32	Wireless network entity (WNE).....	20
7.33	Access gateway (AGW).....	20
7.34	Application server (AS).....	20
7.35	Authentication, authorization and accounting (AAA).....	20
7.36	Border router (BR).....	20
7.37	Breakout gateway control function (BGCF).....	20
7.38	Call session control function (CSCF).....	20
7.39	Databases (DB).....	21
7.40	IP multimedia client.....	21
7.41	IP network.....	21
7.42	Media gateway (MGW).....	21
7.43	Media gateway control function (MGCF).....	21
7.44	Media resource function controller (MRFC).....	21
7.45	Media resource function processor (MRFP).....	21
7.46	Mobile IP home agent (HA).....	21
7.47	Mobile station (MS).....	22
7.48	OSA service capability server (OSA-SCS).....	22
7.49	Policy decision function (PDF).....	22
7.50	Position determining entity (PDE).....	22
7.51	Position server.....	22
7.52	Public switched telephone network (PSTN).....	22
8	Reference points.....	22
8.1	Reference point B.....	22
8.2	Reference point C.....	22
8.3	Reference point D.....	22
8.4	Reference point d.....	22
8.5	Reference point D ₁	23
8.6	Reference point D _i	23
8.7	Reference point E.....	23
8.8	Reference point E ₃	23
8.9	Reference point E ₅	23
8.10	Reference point E ₉	23
8.11	Reference point E ₁₁	23
8.12	Reference point E ₁₂	23
8.13	Reference point e.....	23
8.14	Reference point F.....	23
8.15	Reference point G.....	23
8.16	Reference point H.....	23
8.17	Reference point I.....	23

	Page
8.18 Reference point J	23
8.19 Reference point K.....	24
8.20 Reference point L	24
8.21 Reference point M ₁	24
8.22 Reference point M ₂	24
8.23 Reference point M ₃	24
8.24 Reference point N.....	24
8.25 Reference point N ₁	24
8.26 Reference point O ₁	24
8.27 Reference point O ₂	24
8.28 Reference point P ₁	24
8.29 Reference point Q.....	24
8.30 Reference point Q ₁	24
8.31 Reference point T ₁	24
8.32 Reference point T ₂	24
8.33 Reference point T ₃	25
8.34 Reference point T ₄	25
8.35 Reference point T ₅	25
8.36 Reference point T ₆	25
8.37 Reference point T ₇	25
8.38 Reference point T ₈	25
8.39 Reference point T ₉	25
8.40 Reference point V.....	25
8.41 Reference point X.....	25
8.42 Reference point Y.....	25
8.43 Reference point Z	25
8.44 Reference point Z ₁	25
8.45 Reference point Z ₂	25
8.46 Reference point Z ₃	25
8.47 Reference point 1.....	26
8.48 Reference point 2.....	26
8.49 Reference point 3.....	26
8.50 Reference point 4.....	26
8.51 Reference point 5/Mk.....	26
8.52 Reference point 6.....	26
8.53 Reference point 7.....	26
8.54 Reference point 8/OSA.....	26
8.55 Reference point 9/Mi.....	26
8.56 Reference point 10.....	26
8.57 Reference point 11/Sh	26

	Page
8.58 Reference point 12/ISC	27
8.59 Reference point 13.....	27
8.60 Reference point 14.....	27
8.61 Reference point 15.....	27
8.62 Reference point 16/Cx.....	27
8.63 Reference point 17/Mg.....	27
8.64 Reference point 18.....	27
8.65 Reference point 19.....	27
8.66 Reference point 20.....	27
8.67 Reference point 21.....	27
8.68 Reference point 22.....	27
8.69 Reference point 23.....	27
8.70 Reference point 24/Mr.....	28
8.71 Reference point 25/Mp.....	28
8.72 Reference point 26/PSTN.....	28
8.73 Reference point 27.....	28
8.74 Reference point 28/Go.....	28
8.75 Reference point 29.....	28
8.76 Reference point 30/Mc.....	28
8.77 Reference point 31.....	28
8.78 Reference point 32/Mb.....	28
8.79 Reference point 33/Mb.....	28
8.80 Reference point 34/Mb.....	28
8.81 Reference point 35.....	28
8.82 Reference point 36/Mb.....	29
8.83 Reference point 37/Mb.....	29
8.84 Reference point 38/Mb.....	29
8.85 Reference point 39.....	29
8.86 Reference point 40/Mb.....	29
8.87 Reference point 41.....	29
8.88 Reference point 42/Mb.....	29
8.89 Reference point 43/Mb.....	29
8.90 Reference point 44/Mb.....	29
8.91 Reference point 45/Mb.....	29
8.92 Reference point 46/Mb.....	29
8.93 Reference point 47.....	29
8.94 Reference point 48.....	30
8.95 Reference point 49/Mj.....	30
8.96 Reference point 50.....	30

	Page
9	Technical specifications structure..... 30
10	Technical specifications..... 31
10.1	A series RAN specifications..... 31
10.2	Intersystem specifications 31
10.3	Packet data specifications..... 41
10.4	Services and system aspects specifications 42
10.5	Core network specifications 84

ITU-T Recommendation Q.1742.6

IMT-2000 references (approved as of 31 December 2006) to ANSI-41 evolved core network with cdma2000 access network

1 Scope

This Recommendation identifies the IMT-2000 family member: "ANSI-41 evolved core network with cdma2000 access network". This set of referenced specifications includes those 3GPP2 specifications that were approved as of 31 December 2006.

The core network interfaces identified in this Recommendation and the radio interfaces and radio access network interfaces identified in [ITU-R M.1457-6] constitute a complete system specification for the third generation mobile system for terrestrial usage of this IMT-2000 family member.

It is the intent of ITU-T that the references in this Recommendation are only to specifications that specify the network aspects of this IMT-2000 family member. In the event that a referenced specification also includes material that specifies any of the radio aspects of this IMT-2000 family member, [ITU-R M.1457-6] shall take precedence.

2 References

The following ITU-T Recommendations and other references contain provisions which, through reference in this text, constitute provisions of this Recommendation. At the time of publication, the editions indicated were valid. All Recommendations and other references are subject to revision; users of this Recommendation are therefore encouraged to investigate the possibility of applying the most recent edition of the Recommendations and other references listed below. A list of the currently valid ITU-T Recommendations is regularly published. The reference to a document within this Recommendation does not give it, as a stand-alone document, the status of a Recommendation.

- | | |
|----------------------|---|
| [ITU-R M.1457-6] | ITU-R Recommendation M.1457-6 (2006), <i>Detailed specifications of the radio interfaces of international mobile telecommunications-2000 (IMT-2000)</i> . |
| [ANSI/TIA/EIA 41-D] | ANSI/TIA/EIA 41-D (1997), <i>Cellular Radio Telecommunications Intersystem Operations (ANSI/TIA/EIA-41-D-97)</i> . |
| [ANSI/TIA/EIA 95-B] | ANSI/TIA/EIA 95-B (1999), <i>Mobile Station-Base Station Compatibility Standard for Wideband Spread Spectrum Cellular Systems (ANSI/TIA/EIA-95-B-99)</i> . |
| [ANSI/TIA/EIA 124-D] | ANSI/TIA/EIA 124-D (2001), <i>Wireless Radio Telecommunications Intersystem Non-Signaling Data Communication DMH (Data Message Handler) (ANSI/124-D-2001)</i> . |
| [ANSI/TIA/EIA 136] | ANSI/TIA/EIA 136 (2001), <i>TDMA Cellular PCS (ANSI/TIA/EIA-136, Rev C-2001)</i> . |
| [ANSI/TIA/EIA 553-A] | ANSI/TIA/EIA 553-A (1999), <i>Mobile Station – Base Station Compatibility Standard (ANSI/TIA/EIA-553-A-99)</i> . |
| [ANSI/TIA/EIA 664-A] | ANSI/TIA/EIA 664-A (2000), <i>Wireless Features Description (ANSI/TIA/EIA-664-A-2000)</i> . |

[CWTS-MC-N.S0037]	CWTS-MC-N.S0037 (2002), <i>IP Network Architecture Model for cdma2000 Spread Spectrum Systems</i> .
[CWTS-MC-S.R0005-B]	CWTS-MC-S.R0005-B (2002), <i>Network Reference Model for cdma2000 Spread Spectrum Systems</i> .
[TIA/EIA/IS-91-A]	TIA/EIA/IS-91-A (1999), <i>Base Station – Mobile Station Compatibility Specification for 800 MHz Cellular, Auxiliary, and Residential Services (TIA/EIA/IS-91-A)</i> .
[TIA/EIA/IS-826-A]	TIA/EIA/IS-826-A (2003), <i>TIA/EIA-41-D Based Pre-Paid Charging Enhancements for Circuit-Switched Data and Short Message services</i> .
[TIA/EIA/IS-2000-A]	TIA/EIA/IS-2000-A (2000), <i>CDMA 2000 Series (TIA/EIA/IS-2000 Series Revision A)</i> .
[TIA/EIA/IS-2001-A]	TIA/EIA/IS-2001-A (2001), <i>Interoperability Specifications (IOS) for CDMA2000 Access Network Interfaces (TIA/EIA/IS-2001-A)</i> .
[TIA/EIA TSB-29-E]	TIA/EIA/TSB-29-E (2002), <i>International Implementation of Wireless Telecommunication Systems Compliant with TIA/EIA-41</i> .
[TIA TSB-100-A]	TIA TSB-100-A (2001), <i>Wireless Network Reference Model</i> .
[TTC TS-3GB-S.R0005-Bv1.0]	TTC TS-3GB-S.R0005-Bv1.0 (2001), <i>Network Reference Model for cdma2000 Spread Spectrum Systems</i> .
[TTC TS-3GB-S.R0037-0v3.0]	TTC TS-3GB-S.R0037-0v3.0 (2003), <i>IP Network Architecture Model for cdma2000 Spread Spectrum Systems</i> .
[TTA TTAE.3G-S.R0005-B]	TTA TTAE.3G-S.R0005-B (2001), <i>3GPP2 Network Reference Model for cdma2000 Spread Spectrum Systems</i> .
[TTA TTAT.3G-S.R0037-0v3.0]	TTA TTAT.3G-S.R0037-0v3.0 (2003), <i>IP Network Architecture Model for cdma2000 Spread Spectrum Systems</i> .

3 Definitions

This Recommendation defines the following terms:

3.1 access denial call treatment: A tone, announcement, or call redirection applied as appropriate.

3.2 access network: Network that connects access technologies (such as a radio access network) to the core network.

3.3 active: The MS is available for call delivery. This state is maintained by the MSC, the VLR and the HLR (see also available, inactive and unavailable).

3.4 adjunct MSC: A mobile switching centre (MSC) that is providing adjunct services such as voice response, voice recognition, DTMF tone detection, voice message storage, etc.

3.5 anchor MSC: The mobile switching centre (MSC), that is the first to assign a traffic channel to a call on origination or termination is called the anchor MSC. For the duration of this call, this MSC shall be the anchor (fixed) point in the event that the mobile station (MS) should be handed off to other MSCs.

3.6 authentication: The act of verifying the identity of an entity (e.g., a user, device).

- 3.7 available:** The MS can accept a call delivery (i.e., the MS is in a known location and it is in a state able to accept call deliveries). The availability of an MS to accept a call delivery is maintained only by the MSC (see also active, inactive and unavailable).
- 3.8 base transceiver station:** A piece of radio access network equipment that contains the radios and serves a geographic area.
- 3.9 call delivery:** The process by which calls directed to the cellular subscriber are delivered to the subscriber while roaming in a visited system.
- 3.10 call delivery method:** Method by which a call is delivered to a subscriber in MSC-V.
- 3.11 call disconnect:** The process of requesting the release of a connection between two or more network addresses.
- 3.12 call release:** The process of relinquishing the facilities and circuits used for a call.
- 3.13 call termination:** The process of connecting a subscriber to an incoming call.
- 3.14 candidate MSC:** This term is used during the handoff measurement request by the current serving MSC to reference the MSC that is being requested to provide its best CELL ID and SIGNAL QUALITY values.
- 3.15 cell site:** The physical location of a cell's radio equipment and supporting systems. This term is also used to refer to the equipment located at the cell site.
- 3.16 clearinghouse:** A service used for the exchange and management of information.
- 3.17 data communications:** The digital transmission of information (other than voice).
- 3.18 dialogue:** A user interaction sequence composed of tones and announcements that may gather information.
- 3.19 gateway MSC:** See MSC-G.
- 3.20 home system:** The system which is transmitting the system identifier (SID) (refer to [ANSI/TIA/EIA 553-A] which is recognized by the MS as the "home" SID).
- 3.21 inactive:** The MS is not available for call delivery. The MS may not be registered. The MS may be registered, but is out of radio contact (e.g., missing autonomous registrations) or is intentionally inaccessible for periods of time (e.g., slotted mode, paging frame class, or sleep mode). An inactive MS may accept SMS message deliveries. This state is maintained by the MSC, the VLR and the HLR (see also active, available and unavailable).
- 3.22 market identification (MarketID):** A unique market identifier that is specified by the service provider (e.g., FCC assigned SID, CIBERNET assigned BID – see [TIA/EIA TSB-29]).
- 3.23 mobile assisted handoff (MAHO):** A process where handoff measurements are done by the MS under the control of the MSC and base station. The MSC and base station retain the control over when the handoff actually occurs.
- 3.24 mobility:** The ability to access services from any point in the network. The degree of service availability may depend on the access network capabilities, as well as any service level agreements between the user's home network and the visited network. Types of mobility include personal mobility, service mobility, and terminal mobility.
- 3.25 mobility management:** The set of functions used to manage a mobile user accessing a network other than that user's home network. These functions include communication with the home network for purposes of authentication, authorization, location updating and download of user information.
- 3.26 MSC-G:** An MSC that is capable of the intersystem procedures, defined in this Recommendation, between entities in the network reference model so as to provide service.

- 3.27 MSC-H:** The "home" MSC of an MS which is broadcasting the SID that is recorded in the MS's security and identification memory, and to which the MS's directory number is assigned.
- 3.28 MSC-V:** A "visited" MSC in whose service area a roamer is operating.
- 3.29 network reference model:** The functional entities and the associated interface reference points that may logically comprise a cellular network (see clause 6).
- 3.30 number portability:** A mechanism that allows a user to retain the same directory number, regardless of the subscribed-to service provider. Number portability may be limited to specific geographical areas. In the context of the all-IP network, the term "number portability" refers specifically to E.164 numbers used for telephony.
- 3.31 originating MSC:** The MSC-H or MSC-G that initiates the call delivery procedures defined in this Recommendation.
- 3.32 originating SMS supplementary service:** Services or features that affect SMS message originations and are requested on a per message basis as supported by a particular teleservice, for example, delayed delivery, or message distribution to a list of destinations.
- 3.33 personal mobility:** The ability of users to change their association with one or more terminals at any point and time. The user should continue to receive subscribed and otherwise authorized services as supported by the current MS and access network.
- 3.34 personalized services:** Services that need access to the subscriber profile and/or are dependent on the overall call/session state (of the user) for reasons of service interaction. An example: a call termination service such as "call forward on busy" in [ANSI/TIA/EIA 41-D].
- 3.35 protocol extension:** A mechanism provided to allow systems with a common bilateral agreement to extend the TIA/EIA-41 protocol. There is a range of reserved error codes, operation codes, parameter identifiers (in addition to PRIVATE parameter identifiers), and ranges of values in enumerated parameter types and data fields. The only mechanism to resolve conflicting uses of protocol extension is to standardize their usage. The protocol extension mechanism is used at the risk of the implementation. Protocol extensions should not be used unless the message recipient is known to support them.
- 3.36 radio access network:** The network that connects radio base stations to the core network. The RAN provides and maintains radio-specific functions, which may be unique to a given radio access technology, that allow users to access the core network.
- 3.37 registered:** The HLR has a pointer to a system serving an MS. A registered MS may be active or inactive.
- 3.38 registration:** The procedure by which an MS becomes listed as being present in the service area of an MSC.
- 3.39 remote feature control port (RFC port):** A terminating directory number supporting service profile modification.
- 3.40 roamer port:** A terminating directory number supporting call delivery to mobile stations.
- 3.41 roamer service profile:** The specific set of features, capabilities and/or operating restrictions, other than financial accountability, associated with the subscriber.
- 3.42 roamer validation:** That aspect of roamer service qualification dealing with financial accountability. Also, the general procedure by which a roamer's financial accountability is established.
- 3.43 roaming:** Action whereby users access services while outside of their subscribed home network.

- 3.44 service qualification:** The service capabilities, features and privileges to which an MS is entitled. Also, the general procedure by which such service capabilities, features and privileges become established in an MSC.
- 3.45 serving MSC:** The MSC which currently has the MS obtaining service at one of its cell sites within its coverage area.
- 3.46 signalling:** The information exchanged between the mobile station and the network, or within the network, for the purposes of service provision (e.g., connection establishment).
- 3.47 switch number (SWNO):** A number uniquely identifying a particular switch (i.e., a group of cell sites and the associated switch resources) within a group of switches associated with a common MarketID.
- 3.48 target MSC:** The MSC which was selected from the candidate list as having the cell site with the best signal quality value for the MS during the location request function.
- 3.49 temporary local directory number (TLDN):** A network address temporarily assigned for call setup.
- 3.50 terminating SMS supplementary service:** Services or features that affect SMS message terminations, for example, screening, forwarding, delivery to an MS, delayed delivery while roaming, or distribution to a group based upon a destination address.
- 3.51 termination address:** One or more digits, as determined by the home system, which identify the terminating party. This could include speed call codes (when supported by the home service provider), other mobile telephone numbers or any valid world telephone number.
- 3.52 traffic:** The information generated by the subscriber that is transported on the network (i.e., user voice or data).
- 3.53 unavailable:** The MS cannot accept a normal call delivery (i.e., the MS is in an unknown location or it is in a state unable to accept call deliveries). The availability of an MS to accept a call delivery is maintained only by the MSC (see also active, available and inactive).
- 3.54 unregistered:** A state where the MS is unavailable for any type of termination event and the HLR pointer is not directed to any visited system.
- 3.55 visited network:** The visited network is a carrier's network where a subscriber is currently roaming. The term visited network is more business significant than geographically significant.
- 3.56 visited system:** From the MS's perspective, a system which is transmitting a SID which is not recognized by the MS as the "home" SID. From a network perspective, the system in which an MS is currently registered.

4 Abbreviations and acronyms

This Recommendation uses the following abbreviations and acronyms:

3G	Third Generation
3GPP2	Third Generation Partnership Project (2)
AC	Authentication Centre
ADDS	Application Data Delivery Service
ADPCM	Adaptive Differential Pulse Code Modulation
ADS	Asynchronous Data Service
AH	Answer Hold
AMPS	Advanced Mobile Phone System

AoC	Advice of Charge
API	Application Programming Interface
ARIB	Association of Radio Industries and Businesses
AS	Application Server
BCMCS	Broadcast-Multicast Services
BCSM	Basic Call State Model
BS	Base Station
BSC	Base Station Controller
BTS	Basic Transceiver System
CCF	Call Control Function
CDCP	Call Data Collection Point
CDGP	Call Data Generation Point
CDIS	Call Data Information Source
CDMA	Code Division Multiple Access
CDRP	Call Data Rating Point
CN	Core Network
CNAP	Calling Name Presentation
CNAR	Calling Name Restriction
CNIP	Calling Number Identification Presentation
CSC	Customer Service Centre
CSCF	Call Session Control Function
CWTS	China Wireless Telecommunication Standard
DCCH	Dedicated Control Channel
DFP	Distributed Functional Plane
DMH	Data Message Handler
DP	Detection Point
DP	Data Privacy
DSA	Data Subscriber Authentication
DTMF	Dual Tone Multi-Frequency
E2E	End-to-End
EIR	Equipment Identity Register
EMS	Enhanced Message Service
ESN	Electronic Serial Number
ESP	Encapsulating Security Payload
FCC	Federal Communications Commission
FFMA	File Format for Multimedia Services
FPH	FreePhone

FPLMTS	Future Public Land Mobile Telecommunications Systems – now IMT-2000
GECO	Global Emergency Call Origination
GSM	Global System for Mobile Communications
HA	Home Agent
HLR	Home Location Register
HSS	Home Subscriber Server
IM	IP Multimedia
IMS	IP Multimedia Subsystem
IMSI	International Mobile Subscriber Identity
IMT-2000	International Mobile Telecommunications – 2000
IOTA	IP Over-the-Air
IOTA HCM	Internet Over-the-Air Handset Configuration Management
IP	Internet Protocol
IP	Intelligent Peripheral
IPE	In Path Equipment
IS	Interim Standard
ISDN	Integrated Services Digital Network
ISIM	IP Multimedia Services Identity Module
ISLP	InterSystem Link Protocol
IWF	InterWorking Function
LBSS	Location-Based Services System
LMSD	Legacy Mobile Station Domain
MAP	Mobile Application Part
MC	Multi-Carrier
MC	Message Centre
MDN	Mobile Directory Number
MEID	Mobile Equipment Identifier
MGW	Media Gateway
MM	Multimedia Message
MMS	Multimedia Messaging Service
MS	Mobile Station
MSC	Mobile Switching Centre
MSID	Mobile Station Identifier
NAM	Number Assignment Module
NAMPS	Narrow-band Advanced Mobile Phone Service
NDSS	Network Directed System Selection
NRM	Network Reference Model

OAM&P	Operations, Administration, Maintenance and Provisioning
OSA	Open Service Access
OTAF	Over the-Air Function
OTAPA	Over-the-Air Parameter Administration
OTASP	Over-the-Air Service Provisioning
P-CSCF	Proxy Call Session Control Function
PCF	Packet Control Function
PCS	Personal Communications System
PDE	Positioning-Determining Entity
PDS	Packet Data Subsystem
PDSN	Packet Data Serving Node
PL	Preferred Language
PN	Project Number
PPC	Pre-Paid Charging
PPP	Point-to-Point Protocol
PRC	Premium Rate Charging
RAN	Radio Access Network
RUAC	Rejection of Undesired Annoying Calls
R-UIM	Removable User Identity Module
SC	Subscriber Confidentially
SCF	Selective Call Forwarding
SCF	Session Control Function
SCP	Service Control Point
SCS	Service Capability Server
SDO	Standards Development Organization
SDP	Session Description Protocol
SID	System Identifier
SIP	Session Initiation Protocol
SME	Short Message Entity
SMS	Service Management System
SMS	Short Message Service
SMTP	Simple Mail Transfer Protocol
SN	Service Node
SRG	System Release Guide
SS7	Signalling System 7
SSF	Service Switching Function
SSG	Special Study Group

TFO	Tandem Free Operation
TrFO	Transcoder Free Operation
TMSI	Temporary Mobile Station Identification
TR	Transmit-Receive (as in TR45)
TRAU	Transcoder and Rate Adaptor Unit
TSB	Telecommunications Systems Bulletin
TTA	Telecommunications Technology Association (Korea)
TTC	Telecommunication Technology Committee (Japan)
UICC	Universal Integrated Circuit Card
UIM	User Identity Module
USCF	User Selective Call Forwarding
VASP	Value-Added Service Provider
VLR	Visitor Location Register
WIN	Wireless Intelligent Network
WLL	Wireless Local Loop
WNP	Wireless Number Portability

5 Introduction

The core network for cdma2000 is based on an evolved ANSI-41 second generation mobile system. The core network technical specifications have been developed in a third generation partnership project (approved in 3GPP2 as of 31 December 2006) and transposed to the involved regional standards development organizations (SDOs). The system will support different applications ranging from narrow-band to wideband communications capability with integrated personal and terminal mobility to meet the user and service requirements.

The core network interfaces identified in this Recommendation and the radio interfaces and radio access network interfaces identified in [ITU-R M.1457-6] constitute a complete system specification for the third generation mobile system for terrestrial usage of this IMT-2000 family member.

The descriptions in clauses 6, 7 and 8, and the descriptions of the technical specifications listed in clause 10 are for informative purposes only. Normative information is in the tables for the respective specification.

6 Basic architecture for the ANSI-41 evolved core network with cdma2000 access network family member

The basic architecture for the ANSI-41 evolved core network with cdma2000 access network family member includes a circuit-based and packet-based core network and an all-IP multimedia domain.

The following text is based on clause 2.1 of [CWTS-MC-S.R0005-B], [TIA TSB-100-A], [TTA TTAE.3G-S.R0005-B], [TTC TS-3GB-S.R0005-Bv1.0].

Figure 6-1 presents the network entities and associated reference points that comprise the ANSI-41 evolved core network with cdma2000 access network. The network entities are represented by squares, triangles and rounded corner rectangles; circles represent the reference points. The network

reference model in this Recommendation is the compilation of several reference models currently in use.

- The network reference model is a functional block diagram.
- A network entity represents a group of functions, not a physical device. For example, a mobile switching centre (MSC) is a physical device; it comprises frames, shelves, circuit packs, etc. The physical device may comprise a single network entity such as the MSC, or it may comprise some combination such as the MSC, the visitor location register (VLR), the home location register (HLR), and the authentication centre (AC). The physical realization is an implementation issue; a manufacturer may choose any physical implementation of network entities, either individually or in combination, as long as the implementation meets the functional requirements. Sometimes, for practical reasons, the functional network entity is a physical device. The mobile station (MS) is an excellent example.
- A reference point is a conceptual point that divides two groups of functions. It is not necessarily a physical interface. A reference point only becomes a physical interface when the network entities on either side of it are contained in different physical devices.
- A "collective entity" contains encompassed network entities that are an instance of the collective.
- A "composite entity" contains encompassed network entities that are part of the composite.
- The portion of the figure within the solid line is the core network.

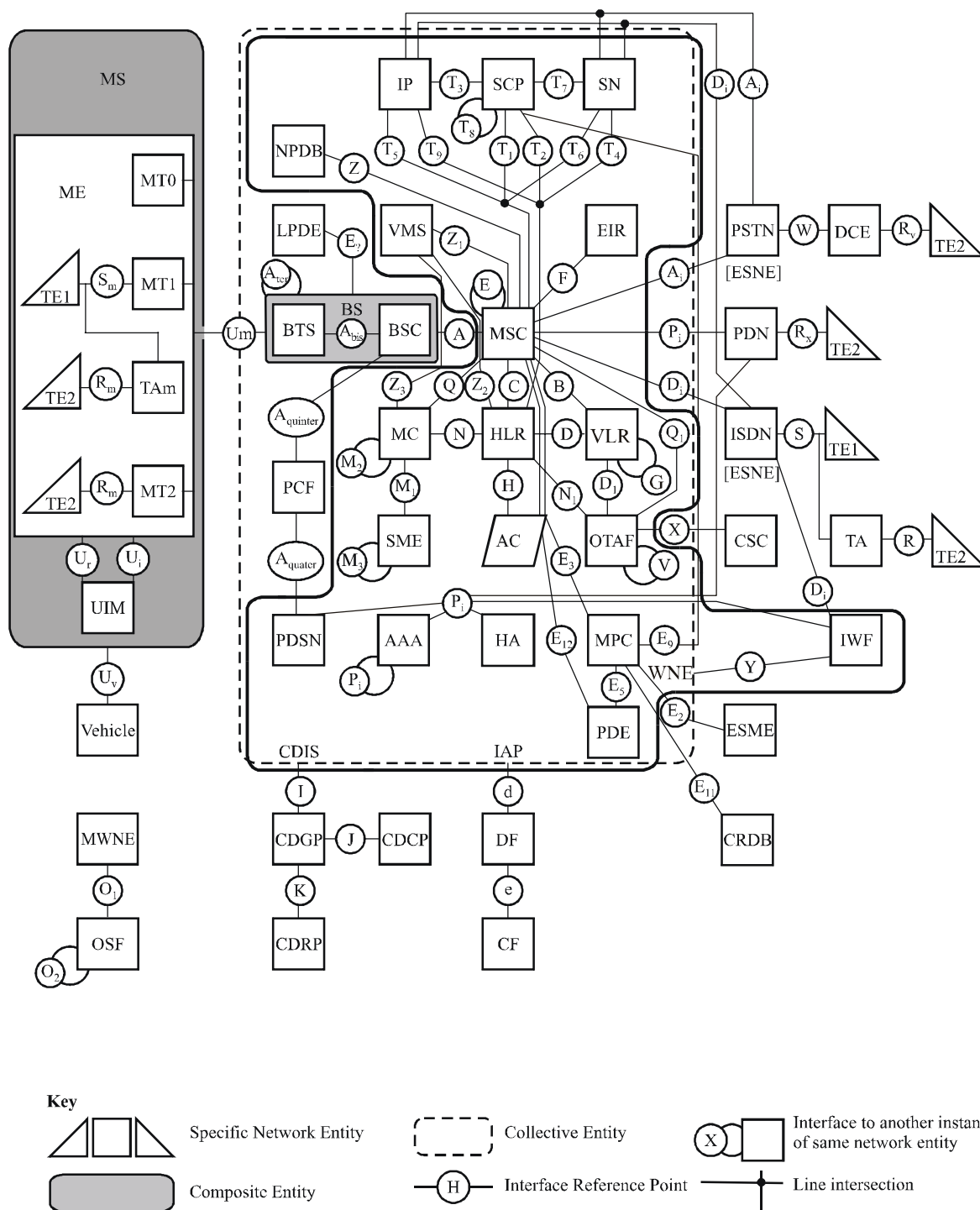

Q.1742.6(07)_F01

Figure 6-1 – ANSI-41 evolved core network with cdma2000 access network reference model

The basic architecture for the ANSI-41 evolved core network with cdma2000 access network family member also includes an all-IP multimedia domain. The following text is based on clause 2.1 of [CWTS-MC-N.S0037], [TTA TTAT.3G-S.R0037-0v3.0], [TTC TS-3GB-S.R0037-0v3.0].

All-IP MMD core network architecture:

Figure 6-2 presents the core network entities and associated reference points that comprise the multimedia domain (MMD) of the wireless all-IP network architecture model. The network entities are represented by squares and rectangles; the interfaces between network entities are reference points identified by numbers. Figure 6-2 includes several reference points that have dual labels. Either of these labels may be used in the specifications relating to these reference points.

NOTE 1 – In Figure 6-2, the network elements and reference points shaded in blue identify the "IP MMD core network".

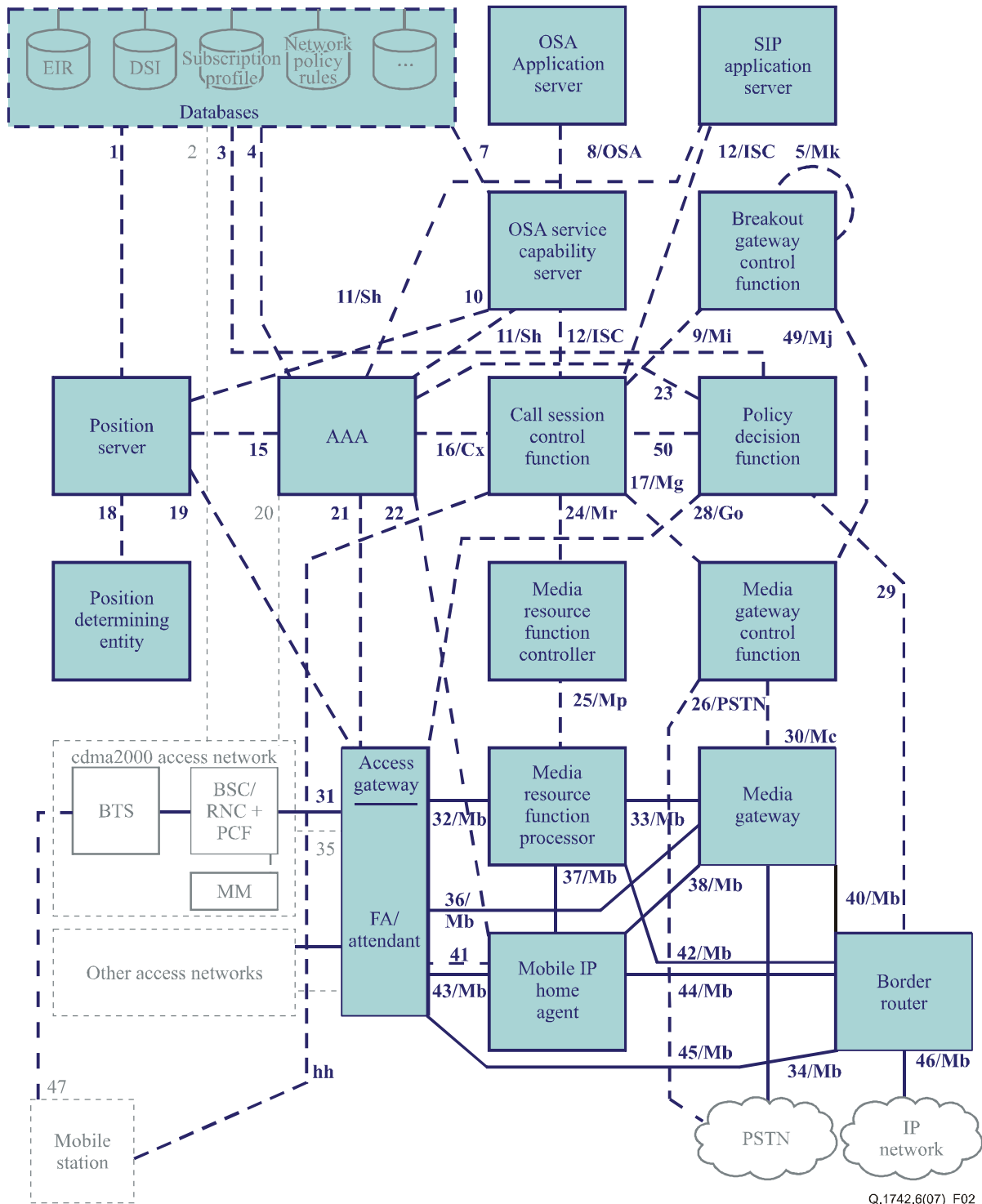

Figure 6-2 – ANSI-41 evolved core network with cdma2000 access network IP MMD core network architecture model

The MMD of the all-IP network offers both general packet data support and multimedia session capabilities. The multimedia session capabilities are built on top of the general packet data support capabilities. The general packet data capabilities may be deployed without the multimedia session capabilities. Some network entities are common to providing both capabilities.

Figure 6-3 shows the entities that comprise the general packet data support portion of the MMD core network. These are known collectively as the packet data subsystem (PDS). Figure 6-3 includes several reference points that have dual labels. Either of these labels may be used in the specifications relating to these reference points.

NOTE 2 – In Figure 6-3, the network elements and reference points highlighted in blue identify the "packet data subsystem".

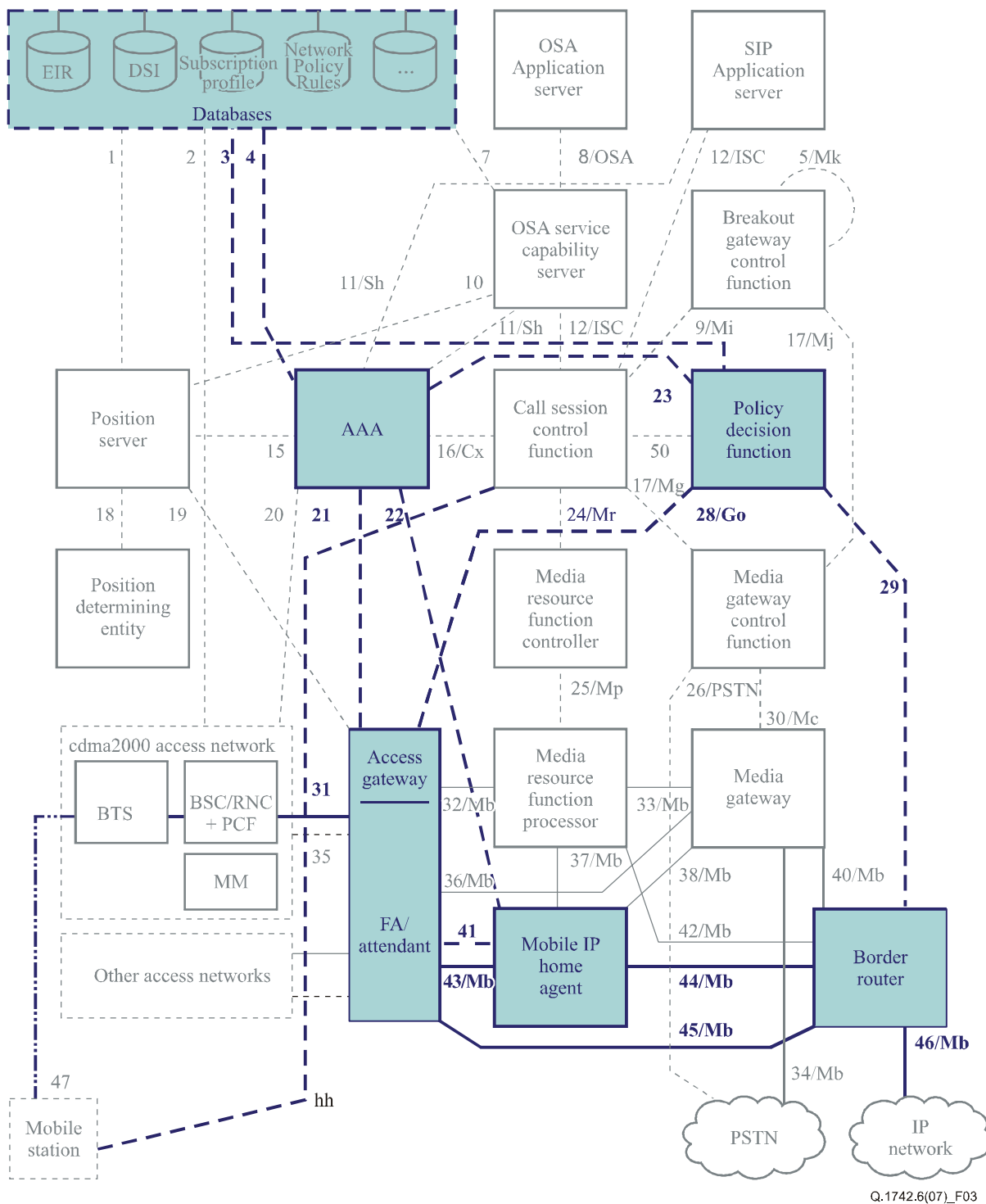

Figure 6-3 – ANSI-41 evolved core network with cdma2000 access network packet data subsystem core network architecture model

Figure 6-4 shows the entities that comprise the multimedia session capabilities of an all-IP network. These entities are known collectively as the IP multimedia session subsystem (IMS). Figure 6-4 includes several reference points that have dual labels. Either of these labels may be used in the specifications relating to these reference points.

NOTE 3 – In Figure 6-4 the "IP multimedia session subsystem" is identified by the network elements and reference points highlighted in blue.

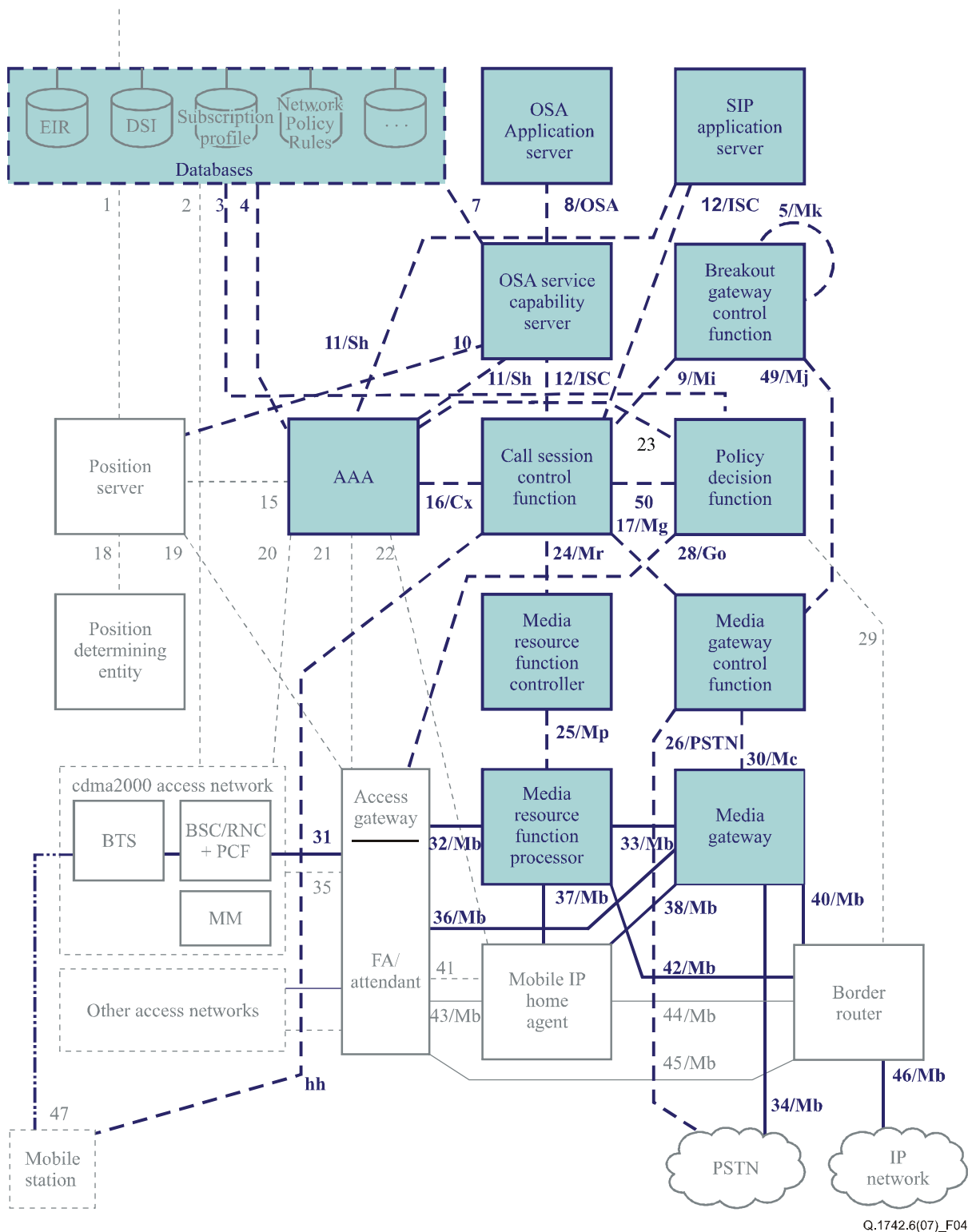

Figure 6-4 – ANSI-41 evolved core network with cdma2000 access network IP multimedia session subsystem core network architecture model

The session control functions within the IMS are logically interconnected in various ways in the session scenarios. Figure 6-5 identifies the reference points within the IMS between these session control entities. In many cases there are dual labels for these reference points, either of which may be used in the applicable specifications.

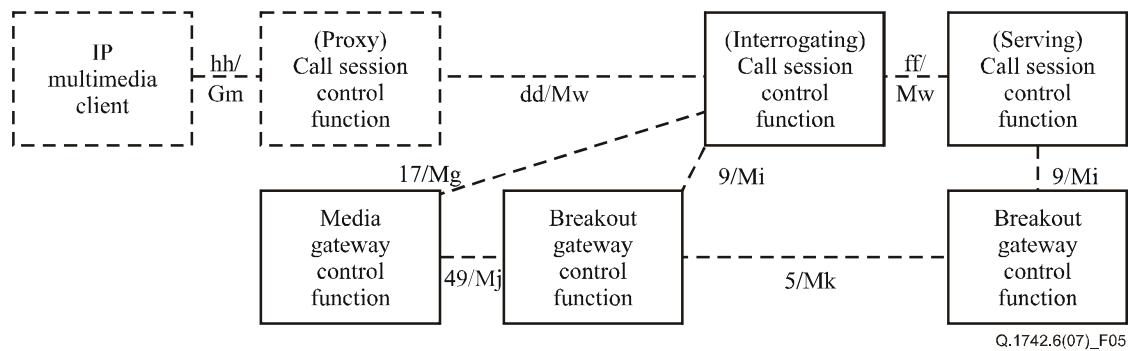

Figure 6-5 – Session control reference model

7 Network entities

Clauses 7.1 to 7.32 are based on reference clause 2.1.1 of [CWTS-MC-S.R0005-B], [TIA TSB-100-A], [TTA TTAE.3G-S.R0005-B], [TTC TS-3GB-S.R0005-Bv1.0] and clauses 7.33 to 7.52 are based on clause 2.1 of [CWTS-MC-N.S0037], [TTA TTAT.3G-S.R0037-0v3.0], [TTC TS-3GB-S.R0037-0v3.0].

7.1 Authentication, authorization and accounting (AAA)

The AAA is an entity that provides IP-based authentication, authorization and accounting. The AAA maintains security associations with peer AAA entities to support intra- and/or inter-administrative domain AAA functions.

- The authentication function provides authentication of users.
- The authorization function of AAA provides authorization of service requests based on subscriber profiles and network policy. It also generates keys required for establishing security associations between PDSNs in access provider networks and HAs in home IP networks.
- The accounting function gathers accounting data concerning the services used by individual subscribers.

7.2 Authentication centre (AC)

The AC is an entity that manages the authentication information related to the MS. The AC may or may not be located within, and be indistinguishable from, an HLR. An AC may serve more than one HLR.

7.3 Call data collection point (CDCP)

The CDCP is the entity that collects the call detail information.

7.4 Call data generation point (CDGP)

The CDGP is an entity which provides call detail information to the CDCP (in ANSI-124 format). This may be the entity that converts call detail information from a proprietary format into a standard format. All information from the CDGP to the CDCP must be in this standard format.

7.5 Call data information source (CDIS)

The CDIS is an entity that can be the source of call detail information. This information may be in proprietary format. It is not required to be in the standard format.

7.6 Call data rating point (CDRP)

The CDRP is the entity that takes the unrated call detail information and applies the applicable charge- and tax-related information. The charge and tax information is added using the standard format.

7.7 Collection function (CF) – [Intercept]

The CF is an entity that is responsible for collecting intercepted communications for a lawfully authorized law enforcement agency.

The CFs typically include:

- The ability to receive and process call content information for each intercept subject.
- The ability to receive and process information regarding each intercept subject (e.g., call associated or non-call associated) from the delivery function.

7.8 Coordinate routing database (CRDB)

The CRDB is an entity that stores information to translate a given position, expressed as a latitude and longitude, to a string of digits.

7.9 Customer service centre (CSC)

The CSC is an entity where service provider representatives receive telephone calls from customers wishing to subscribe to initial wireless service or request a change in the customer's existing service. The CSC interfaces proprietarily with the OTAF to perform network- and MS-related changes necessary to complete the service provisioning request.

7.10 Delivery function (DF) – [Intercept]

The DF is an entity that is responsible for delivering intercepted communications to one or more collection functions.

The DFs typically include:

- The ability to accept call contents for each intercept subject over one or more channels from each access function.
- The ability to deliver call contents for each intercept subject over one or more channels to a collection function as authorized for each law enforcement agency.
- The ability to accept information over one or more data channels and combine that information into a single data flow for each intercept subject.
- The ability to filter or select information on an intercept subject before delivery to a collection function as authorized for a particular law enforcement agency.
- The optional ability to detect audio in-band DTMF digits for translation and delivery to a collection function as authorized for a particular law enforcement agency.
- The ability to duplicate and deliver information on the intercept subject to one or more collection functions as authorized for each law enforcement agency.
- The ability to provide security to restrict access.

7.11 Equipment identity register (EIR)

The EIR is an entity that is the register to which user equipment identity may be assigned for record purposes. The nature, purpose and utilization of this information is an area for further study.

7.12 Home agent (HA)

The HA is an entity that:

- authenticates mobile IP registrations from the MS;
- redirects packets to the foreign agent component of the PDSN, and optionally receives and routes reverse packets from the foreign agent component of the PDSN;
- may establish, maintain and terminate secure communications to the PDSN;
- receives provisioning information from the AAA function for users;
- may assign a dynamic home IP address.

7.13 Home location register (HLR)

The HLR is the location register to which a user identity is assigned for record purposes such as subscriber information (e.g., electronic serial number (ESN), mobile directory number (MDN), profile information, current location, authorization period).

7.14 Intelligent peripheral (IP)

The IP is an entity that performs specialized resource functions such as playing announcements, collecting digits, performing speech-to-text or text-to-speech conversion, recording and storing voice messages, facsimile services, data services, etc.

7.15 Intercept access point (IAP)

The IAP is an entity that provides access to the communications to or from the equipment, facilities or services of an intercept subject.

7.16 Interworking function (IWF)

The IWF is an entity that provides information conversion for one or more WNEs. An IWF may have an interface to a single WNE providing conversion services. An IWF may augment an identified interface between two WNEs, providing conversion services to both WNEs.

7.17 Local position determining entity (LPDE)

The LPDE facilitates the determination of the position or geographical location of a wireless terminal. Each LPDE supports one or more position-determining technologies. Multiple LPDEs using the same technology may serve the coverage area of a mobile position centre (MPC) and the multiple LPDEs each using a different technology may serve the same coverage area of an MPC. Local PDEs (LPDEs) reside at the base station (BS).

7.18 Managed wireless network entity (MWNE)

A MWNE (within the collective entity) or any specific network entity having operation system wireless management needs, including another operations system.

7.19 Message centre (MC)

The MC is an entity that stores and forwards short messages. The MC may also provide supplementary services for short message service (SMS).

7.20 Mobile position centre (MPC)

The MPC selects a PDE to determine the position of a mobile station. The MPC may restrict access to position information (e.g., require that the MS be engaged in an emergency call or only release position information to authorized network entities).

7.21 Mobile switching centre (MSC)

The MSC switches circuit mode MS-originated or MS-terminated traffic. An MSC is usually connected to at least one BS. It may connect to the other public networks (PSTN, ISDN, etc.), other MSCs in the same network, or MSCs in different networks. The MSC may store information to support these capabilities.

7.22 Number portability database (NPDB)

The NPDB is an entity which provides portability information for portable directory numbers.

7.23 Over-the-air service provisioning function (OTAF)

The OTAF is an entity that interfaces proprietarily to CSCs to support service provisioning activities. The OTAF interfaces with the MSC to send MS orders necessary to complete service provisioning requests.

7.24 Packet data network (PDN)

A PDN, such as the Internet, provides a packet data transport mechanism between processing network entities capable of using such services.

7.25 Packet data serving node (PDSN)

The PDSN routes MS-originated or MS-terminated packet data traffic. The PDSN establishes, maintains and terminates link layer sessions to MSs. The PDSN may interface to one or more MS(s) and may interface to one or more PDN(s).

7.26 Position-determining entity (PDE)

A PDE facilitates determination of the position or geographical location of a wireless terminal. Each PDE supports one or more position-determining technologies. Multiple PDEs using the same technology may serve the coverage area of a mobile position centre (MPC) and multiple PDEs, each using a different technology, may serve the same coverage area of an MPC.

7.27 Service control point (SCP)

The SCP is an entity that acts as a real-time database and transaction processing system that provides service control and service data functionality.

7.28 Service node (SN)

The SN is an entity that provides service control, service data, specialized resources and call control functions to support bearer-related services.

7.29 Short message entity (SME)

The SME is an entity that composes and decomposes short messages. A SME may or may not be located within, and be indistinguishable from, an HLR, MC, VLR, MS or MSC.

7.30 Visitor location register (VLR)

The VLR is the location register other than the HLR used by an MSC to retrieve information for handling of calls to or from a visiting subscriber. The VLR may or may not be located within, and be indistinguishable from, an MSC. The VLR may serve more than one MSC.

7.31 Voice message centre (VMS)

A VMS stores received voice messages, data messages (e.g., email) or both message types, and supports a method to retrieve previously stored messages. A VMS may also support (on a directory

number basis) notification of the presence of stored messages and notification of a change in the number of voice messages, data messages or both message types that are waiting retrieval.

7.32 Wireless network entity (WNE)

A network entity in the wireless collective entity.

7.33 Access gateway (AGW)

The cdma2000 AGW consists of the PDSN and other logical functions required to interface the core network to the cdma2000 RAN.

- The PDSN routes MS-originated or MS-terminated packet data traffic. The PDSN establishes, maintains and terminates link layer sessions to MSs. The PDSN may interface to one or more MSs and may interface to one or more PDNs.

7.34 Application server (AS)

Application servers provide value-added network-based services for wireless subscribers. These services may be accessed via the OSA service capability server (OSA-SCS) or accessed directly from the user's mobile station via other network entities, by-passing the OSA-SCS.

7.35 Authentication, authorization and accounting (AAA)

The AAA is an entity that provides IP-based authentication, authorization and accounting. The AAA maintains security associations with peer AAA entities to support intra- and/or inter-administrative domain AAA functions.

- The authentication function is an entity that provides authentication of terminal devices and subscribers.
- The authorization function of AAA provides authorization of requests for services and/or bandwidth, etc., and has access to the policy repository, directory services, subscriber profiles and the device register.
- The accounting function gathers data concerning the services, QoS and multimedia resources requested and used by individual subscribers.

7.36 Border router (BR)

The BR connects the core network with peer networks (e.g., other service providers, corporate networks, Internet). The BR performs IP packet routing, exterior gateway routing protocols, and policing of incoming and outgoing traffic, ensuring traffic complies with defined service level agreements established with peer networks. The BR may intercept any QoS allocation request and issue a request to the policy decision function (PDF), which shall verify that the requested inbound and/or outbound QoS is available. A successful response from the PDF may cause the BR to forward the bandwidth allocation request to its final destination.

7.37 Breakout gateway control function (BGCF)

The BGCF selects the network in which PSTN breakout is to occur and, within the network where the breakout is to occur, selects the MGCF.

7.38 Call session control function (CSCF)

The CSCF establishes, monitors, supports and releases multimedia sessions, and manages the user's service interactions.

7.39 Databases (DB)

The information in the core network DBs may include but is not limited to EIR, dynamic subscriber information, network policy rules and subscriber profile data.

7.40 IP multimedia client

The IP multimedia client communicates with application servers, P-CSCFs and other IP multimedia clients. The IP multimedia client is an application that resides in the MS.

7.41 IP network

The IP network corresponds to IP-based packet data networks that provide a transport mechanism between the core network and external IP networks. IP network represents packet networks connected to the core network including the public Internet, private IP backbone networks and private IP networks such as corporate intranets.

7.42 Media gateway (MGW)

The MGW provides an interface between the packet environment of the core network and the circuit switched environment of the PSTN for bearer traffic, when equipped with circuit capabilities. The MGW may provide vocoding and/or transcoding functions to the bearer traffic. The MGW may also provide modem functions to convert digital byte streams to and from audio modem tones placed on circuits, and may provide the capability to terminate point-to-point protocol (PPP) connections. It also provides policy enforcement relative to its activities and resources.

7.43 Media gateway control function (MGCF)

The MGCF provides the ability to control a media gateway through standardized interfaces. Such control includes allocation and deallocation of resources of the media gateway, as well as modification of the usage of those resources.

7.44 Media resource function controller (MRFC)

The MRFC, in conjunction with the MRFP, provides a set of resources within the core network that are useful in supporting services to subscribers. The MRFC, in conjunction with the MRFP, provides multi-way conference bridges, announcement playback services, tone playback services, etc.

7.45 Media resource function processor (MRFP)

The MRFP, in conjunction with the controlling entity, provides multi-way conference bridges, announcement playback services, tone playback services, etc.

7.46 Mobile IP home agent (HA)

The HA provides two major functions: registering the current point of attachment of the user, and forwarding of IP packets to and from the current point of attachment (IPv4 care of address [CoA] and/or IPv6 co-located CoA) of the user. The HA accepts registration requests using the mobile IP protocol and uses the information in those requests to update internal information about the current point of attachment of the user, i.e., the current IP address to be used to transmit and receive IP packets to and from that user. The HA interacts with the AAA to receive mobile IP registration requests that have been authenticated, and to return mobile IP registration responses. The HA also interacts with the access gateway to receive subsequent mobile IP registration requests. The HA may interact with several network entities in performing its work of forwarding IP packets to the current point of attachment of the user.

7.47 Mobile station (MS)

The MS is a wireless terminal used by subscribers to access the legacy MS domain or the IP multimedia domain services over a radio interface. MSs include portable units (e.g., hand-held units), units installed in vehicles, and somewhat paradoxically, fixed location MSs. The MS is the interface equipment used to terminate the radio path at the subscriber. An MS is an ME with a programmed UIM.

7.48 OSA service capability server (OSA-SCS)

The OSA-SCS provides access to network resources needed during service application execution. The interface towards the application server uses application programming interfaces such as open service architecture (OSA). The interfaces towards other network entities use the relevant protocols.

7.49 Policy decision function (PDF)

The PDF provides management of core network QoS resources within its own core network necessary to support services to network users. It communicates with the access gateway to provide authorization of resource allocations. The PDF makes policy decisions with regard to use of core network QoS resources within its own network, including consideration of service level agreements (SLAs). QoS policy information for network resource utilization may be forwarded to and cached by the PDF.

NOTE – The maintenance of SLAs is for further study.

7.50 Position determining entity (PDE)

The PDE communicates with the position server to determine the precise geographic position of the MS based on input data provided by the position server.

7.51 Position server

The position server provides geographic position information to requesting entities.

7.52 Public switched telephone network (PSTN)

The PSTN is defined in accordance with the appropriate applicable national and regional standards.

8 Reference points

Clauses 8.1 to 8.46 are based on clause 2.1.2 of [CWTS-MC-S.R0005-B], [TIA TSB-100-A], [TTA TTAE.3G-S.R0005-B], [TTC TS-3GB-S.R0005-Bv1.0], and clauses 8.47 to 8.96 are based on clause 2.1 of [CWTS-MC-N.S0037], [TTA TTAT.3G-S.R0037-0v3.0], [TTC TS-3GB-S.R0037-0v3.0].

8.1 Reference point B

Reference point B is the interface between the MSC and the VLR.

8.2 Reference point C

Reference point C is the interface between the MSC and the HLR.

8.3 Reference point D

Reference point D is the interface between the VLR and HLR.

8.4 Reference point d

Reference point d is the interface between an IAP and the DF.

8.5 Reference point D₁

Reference point D₁ is the interface between the OTAF and the VLR.

8.6 Reference point D_i

Reference point D_i is the interface between:

- the IP and the ISDN;
- the IWF and the ISDN;
- the MSC and the ISDN (ESBE);
- the SN and the ISDN.

8.7 Reference point E

Reference point E is the interface between the MSC and MSC.

8.8 Reference point E₃

Reference point E₃ is the interface between the MPC and the MSC.

8.9 Reference point E₅

Reference point E₅ is the interface between the MPC and the PDE.

8.10 Reference point E₉

Reference point E₉ is the interface between the MPC and the SCP.

8.11 Reference point E₁₁

Reference point E₁₁ is the interface between the CRDB and the MPC.

8.12 Reference point E₁₂

Reference point E₁₂ is the interface between the MSC and the PDE.

8.13 Reference point e

Reference point e is the interface between the CF and the DF.

8.14 Reference point F

Reference point F is the interface between the MSC and the EIR.

8.15 Reference point G

Reference point G is the interface between the VLR and the VLR.

8.16 Reference point H

Reference point H is the interface between the HLR and the AC.

8.17 Reference point I

Reference point I is the interface between the CDIS and the CDGP.

8.18 Reference point J

Reference point J is the interface between the CDGP and the CDCP.

8.19 Reference point K

Reference point K is the interface between the CDGP and the CDRP.

8.20 Reference point L

Reserved.

8.21 Reference point M₁

Reference point M₁ is the interface between the SME and the MC.

8.22 Reference point M₂

Reference point M₂ is the MC to MC interface.

8.23 Reference point M₃

Reference point M₃ is the SME to SME interface.

8.24 Reference point N

Reference point N is the interface between the HLR and the MC.

8.25 Reference point N₁

Reference point N₁ is the interface between the HLR and the OTAF.

8.26 Reference point O₁

Reference point O₁ is the interface between an MWNE and the OSF.

8.27 Reference point O₂

Reference point O₂ is the interface between an OSF and the OSF.

8.28 Reference point P_i

Reference point P_i is the interface between:

- the AAA and the AAA;
- the AAA and the PDN;
- the IWF and the PDN;
- the MSC and the PDN; plus
- the PDSN and the PDN.

8.29 Reference point Q

Reference point Q is the interface between the MC and the MSC.

8.30 Reference point Q₁

Reference point Q₁ is the interface between the MSC and the OTAF.

8.31 Reference point T₁

Reference point T₁ is the interface between the MSC and the SCP.

8.32 Reference point T₂

Reference point T₂ is the interface between the HLR and the SCP.

8.33 Reference point T₃

Reference point T₃ is the interface between the IP and the SCP.

8.34 Reference point T₄

Reference point T₄ is the interface between the HLR and the SN.

8.35 Reference point T₅

Reference point T₅ is the interface between the IP and the MSC.

8.36 Reference point T₆

Reference point T₆ is the interface between the MSC and the SN.

8.37 Reference point T₇

Reference point T₇ is the interface between the SCP and the SN.

8.38 Reference point T₈

Reference point T₈ is the interface between the SCP and the SCP.

8.39 Reference point T₉

Reference point T₉ is the interface between the HLR and the IP.

8.40 Reference point V

Reference point V is the interface between the OTAF and the OTAF.

8.41 Reference point X

Reference point X is the interface between the CSC and the OTAF.

8.42 Reference point Y

Reference point Y is the interface between a wireless network entity (WNE) and the IWF.

8.43 Reference point Z

Reference point Z is the interface between the MSC and the NPDB.

8.44 Reference point Z₁

Reference point Z₁ is the interface between the MSC and the VMS.

8.45 Reference point Z₂

Reference point Z₂ is the interface between the HLR and the VMS.

8.46 Reference point Z₃

Reference point Z₃ is the interface between the MC and the VMS.

An interface exists when two network entities are interconnected through exactly one signalling or bearer stream reference point. The reference points and their associated network entities are as follows.

8.47 Reference point 1

Reference point 1 is the signalling interface between the databases and the position server (multimedia domain only).

8.48 Reference point 2

Reference point 2 is the signalling interface between the databases and the cdma2000 access network.

8.49 Reference point 3

Reference point 3 is the signalling interface between the databases and the policy decision function (multimedia domain only).

8.50 Reference point 4

Reference point 4 is the signalling interface between the databases and the AAA.

8.51 Reference point 5/Mk

Reference point 5/Mk is the signalling interface between breakout gateway control functions (multimedia domain only).

8.52 Reference point 6

Reference point 6 is the signalling interface between the databases and the legacy MS domain support (legacy MS domain only).

8.53 Reference point 7

Reference point 7 is the signalling interface between the OSA service capability server and the databases.

8.54 Reference point 8/OSA

Reference point 8/OSA is the signalling interface between the OSA application server and the OSA service capability server. Reference point 8/OSA may employ interfacing techniques that support a wide spectrum of capabilities, ranging from secure (e.g., application programming interfaces such as Parlay, used for un-trusted parties) to non-secure (e.g., used for trusted parties).

8.55 Reference point 9/Mi

Reference point 9/Mi is the signalling interface between the visited network's BGCF and the home service network's serving-CSCF.

8.56 Reference point 10

Reference point 10 is the signalling interface between the position server and the OSA service capability server (multimedia domain only).

8.57 Reference point 11/Sh

Reference point 11/Sh is the signalling interface between the SIP application server and the AAA and between the OSA service capability server and the AAA for user's service authentication and/or authorization, and for retrieving information from the MMD database (multimedia domain only).

8.58 Reference point 12/ISC

Reference point 12/ISC is the signalling interface between the SIP application server and call session control function and between the OSA service capability server and the call session control function for service control (multimedia domain only).

8.59 Reference point 13

Reference point 13 is the signalling interface between the legacy MS domain support and the PSTN (legacy MS domain only).

8.60 Reference point 14

Reference point 14 is the signalling interface between the legacy MS domain support and the MAP [ANSI/TIA/EIA-4-D] and GSM (legacy MS domain only).

8.61 Reference point 15

Reference point 15 is the signalling interface between the position server and AAA.

8.62 Reference point 16/Cx

Reference point 16/Cx is the signalling interface between the AAA and the call session control function (multimedia domain only).

8.63 Reference point 17/Mg

Reference point 17/Mg is the signalling interface between the call session control function and the media gateway control function (multimedia domain only).

8.64 Reference point 18

Reference point 18 is the signalling interface between the position server and the position determining entity.

8.65 Reference point 19

Reference point 19 is the signalling interface between the position server and the access gateway (multimedia domain only).

8.66 Reference point 20

Reference point 20 is the signalling interface between the AAA and the cdma2000 access network (multimedia domain only).

8.67 Reference point 21

Reference point 21 is the signalling interface between the AAA and access gateway.

8.68 Reference point 22

Reference point 22 is the signalling interface between the AAA and the mobile IP home agent.

8.69 Reference point 23

Reference point 23 is the signalling interface between the AAA and the policy decision function (multimedia domain only).

8.70 Reference point 24/Mr

Reference point 24/Mr is the signalling interface between the call session control function and the media resource function controller (multimedia domain only).

8.71 Reference point 25/Mp

Reference point 25/Mp is the signalling interface between the media resource function controller and the media resource function processor.

8.72 Reference point 26/PSTN

Reference point 26/PSTN is the signalling interface between the media gateway control function and the PSTN (multimedia domain only).

8.73 Reference point 27

Reference point 27 is the bearer stream interface between the cdma2000 access network and the media gateway (legacy MS domain only).

8.74 Reference point 28/Go

Reference point 28/Go is the signalling interface between the policy decision function and access gateway.

8.75 Reference point 29

Reference point 29 is the signalling interface between policy decision function and the border router.

8.76 Reference point 30/Mc

Reference point 30/Mc is the signalling interface between the media gateway control function and the media gateway (multimedia domain only).

8.77 Reference point 31

Reference point 31 is the bearer stream interface between cdma2000 access network and the access gateway.

8.78 Reference point 32/Mb

Reference point 32/Mb is the bearer stream interface between the access gateway and the media resource function processor (multimedia domain only).

8.79 Reference point 33/Mb

Reference point 33/Mb is the bearer stream interface between the media resource function processor and the media gateway.

8.80 Reference point 34/Mb

Reference point 34/Mb is the bearer stream interface between the media gateway and the PSTN.

8.81 Reference point 35

Reference point 35 is the signalling interface between the cdma2000 access network and the access gateway.

8.82 Reference point 36/Mb

Reference point 36/Mb is the bearer stream interface between the access gateway and the media gateway (multimedia domain only).

8.83 Reference point 37/Mb

Reference point 37/Mb is the bearer stream interface between the media resource function processor and the mobile IP home agent (multimedia domain only).

8.84 Reference point 38/Mb

Reference point 38/Mb is the bearer stream interface between the media gateway and the mobile IP home agent (multimedia domain only).

8.85 Reference point 39

Reference point 39 is the signalling interface between the media gateway and the legacy MS domain support (legacy MS domain only).

8.86 Reference point 40/Mb

Reference point 40/Mb is the bearer stream interface between the media gateway and the border router.

8.87 Reference point 41

Reference point 41 is the signalling interface between the access gateway and the mobile IP home agent.

8.88 Reference point 42/Mb

Reference point 42/Mb is the bearer stream interface between the media resource function processor and the border router.

8.89 Reference point 43/Mb

Reference point 43/Mb is the bearer stream interface between the access gateway and the mobile IP home agent.

8.90 Reference point 44/Mb

Reference point 44/Mb is the bearer stream interface between the mobile IP home agent and the border router.

8.91 Reference point 45/Mb

Reference point 45/Mb is the bearer stream interface between the access gateway and the border router.

8.92 Reference point 46/Mb

Reference point 46/Mb is the bearer stream interface between the border router and the IP network.

8.93 Reference point 47

Reference point 47 is the radio link (air interface) between the mobile station and the cdma2000 access network.

8.94 Reference point 48

Reference point 48 is the signalling interface between the cdma2000 access network and the legacy MS domain support (legacy MS domain only).

8.95 Reference point 49/Mj

Reference point 49/Mj is the signalling interface between the breakout gateway control function and the media gateway control function (multimedia domain only).

8.96 Reference point 50

Reference point 50 is the signalling interface between the policy decision function and the P-CSCF (multimedia domain only).

9 Technical specifications structure

This clause provides an overview of the specifications for this IMT-2000 family member based on ANSI-41 evolved core network with cdma2000 access network. Details for these specifications may be found in clause 10.

The following text describes the numbering scheme for the specifications and reports for the 3GPP2 third generation mobile system.

The 3GPP2 document numbering scheme is indicated as follows:

A.Bcccc-w-x version y.z

where:

- 1) A denotes the TSG (A, C, N, P, S) which developed the specification where:
 - TSG-A develops RAN (i.e., A-interface) specifications;
 - TSG-C develops air interface specifications;
 - TSG-N develops intersystem interface specifications;
 - TSG-P develops packet data specifications;
 - TSG-S develops service and system aspects specifications including stage 1 requirements descriptions and OAM&P specifications.
- 2) B denotes project, report, specification (P, R, S).
- 3) cccc denotes a four (4) digit number which identifies the specific specification.
- 4) w denotes revision:
 - 0 is the first release (0th revision);
 - A is the first revision;
 - and so on.
- 5) x denotes whether this is the prime revision or an addendum:
 - 0 is the prime revision, and is used when the document is first created;
 - 1 is the first addendum;
 - 2 is the second addendum;
 - and so on.
- 6) y is the "point release" indicator – 0 is used when the document is first created; the number is incremented whenever approved for publishing by the plenary of a TSG (e.g., 1 is the first approval by the plenary for publishing).

- 7) z is an internal edit level. The internal edit level z is always reset to 0 when the document is approved by the applicable plenary. It is incremented by the entity (e.g., working group) that is developing the document for each new edit release.

NOTE 1 – If the designator w and the designator x are both equal to 0, then neither designator needs to be included.

NOTE 2 – The document reference section does not need to include "version y.z" unless specifically needed to resolve a technical incompatibility that would exist.

10 Technical specifications

All dates in the tables of clause 10 are formatted day-month-year. If no day is shown for the document, then the format is -month-year¹.

10.1 A series RAN specifications

The 3GPP2 A series RAN specifications are outside of the scope of this Recommendation. The radio access network to core network interface specifications for the cdma2000 (ANSI-41 evolved core network with cdma2000 access network) system family will be referenced in a new issue of [ITU-R M.1457-6].

10.2 Intersystem specifications

10.2.1 N.S0003-0 v.1.0 User Identity Module (April 2001)

This standard defines the enhancements required for the support of mobile stations equipped with user identification modules (UIM). The UIM provides functionality to certain types of mobile stations to enable them to operate in the wireless network.

This document defines requirements for the wireless network to support operation of UIM-equipped mobile stations. A UIM provides compatible mobile stations with the parameters required of mobile stations operating in the TIA/EIA-41 environment and specific additional functionality unique to UIM-equipped mobile stations.

The UIM can be in one of two forms, as either integrated within the mobile or removable that can be inserted or removed from the mobile equipment. This document addresses removable UIM (R-UIM) only.

	Document No.	Version	Status	Issued date	Location
CCSA	CWTS-MC-N.S0003-0	6.0	Published	-02-2002	http://www.ccsa.org.cn/english/tc/files.php?docpath=ITU-R/M.1457/M.1457-4/MC
TIA	TIA/EIA/IS-808		Published	-- 12-2000	http://www.tiaonline.org/standards/catalog/search.cfm
TTA	TTAE.3G-N.S0003	1	Approved	13-07-2000	http://www.tta.or.kr/standardDB/stnfile/TTAE_3G-N_S0003.zip
TTC	TS-3GB-N.S0003v1.0	1.0	TTC Published	29-05-2001	http://www.ttc.or.jp/imt2000/ts/tsns0003-v10.pdf

¹ Note on nomenclature of TIA documents: before TIA was accredited, documents were created under EIA. After TIA was accredited as a standards development organization, documents were named beginning with TIA/EIA. TIA documents can now stand by themselves so, since 2000, documents are now titled TIA only. The IS was an interim standard valid for 3 years and that naming system is no longer used for new documents.

10.2.2 N.S0004-0 v 1.0 WIN Phase 2 (April 2001)

- Triggers for preferred language.
- Advice of charge.
- Rejection of undesired annoying calls.
- Premium rate charging.
- Freephone.

Premium rate charging (PRC), freephone (FPH) and advice of charge (AoC) are charging-related services that provide a set of advanced wireless charging capabilities. Rejection of undesired annoying calls (RUAC) is a screening service that blocks undesired annoying calls to the subscriber. Enhanced preferred language (EPL) uses wireless intelligent network (WIN) capabilities to provide announcements to the subscriber in the subscriber's preferred language. This specification presents a recommended plan for the implementation of WIN capabilities that support these features. The WIN capabilities are for use in the wireless radiotelephone service.

	Document No.	Version	Status	Issued date	Location
CCSA	CWTS-MC-N.S0004-0	1.0	Published	-02-2002	http://www.ccsa.org.cn/english/tc/files.php?docpath=/ITU-R/M.1457/M.1457-4/MC
TIA	TIA/EIA/IS-848		Published	-- 12-2000	http://www.tiaonline.org/standards/catalog/search.cfm
TTA	TTAE.3G-N.S0004	1	Approved	13-07-2000	http://www.tta.or.kr/standardDB/stnfile/TTAE_3G-N_S0004.zip
TTC	TS-3GB-N.S0004-0v1.0	1.0	TTC Published	29-05-2001	http://www.ttc.or.jp/imt2000/ts/tsns0004-0v10.pdf

10.2.3 N.S0005-0 Version 1.0 Cellular Radiotelecommunications Intersystem Operations (no date)

(O) The purpose of this document is to identify those cellular services which require intersystem cooperation, to present the general background against which those services are to be provided, and to summarize the principle considerations which have governed and directed the particular approaches taken in the procedural recommendations.

	Document No.	Version	Status	Issued date	Location
CCSA	YDT 1031-1999	1.0	Published	-12-1999	http://www.ccsa.org.cn/english/tc/files.php?docpath=/ITU-R/M.1457/M.1457-4/MC
TIA	TIA/EIA-41-D		Published	-- 12-1997	http://www.tiaonline.org/standards/catalog/search.cfm
TTA	TTAE.3G-N.S0005	1	Approved	13-07-2000	http://www.tta.or.kr/standardDB/stnfile/TTAE_3G-N_S0005.zip

10.2.4 N.S0006 Version 1.0.0 PCS Multi-band Based on IS-41-C Revision: 0 (28 January 2000)

The 3GPP2 document was withdrawn.

10.2.5 N.S0008 Version 1.0 Circuit Mode Services (no date)

This standard presents a recommended plan for the implementation of uniform features for use in the cellular radiotelephone service. Its intent is to describe services and features so that the manner in which a subscriber may place calls using such features and services may remain reasonably consistent from system to system. It is not intended to require that specific service offerings be required of all service providers.

Services:

- Asynchronous data service (ADS).
- Data privacy (DP).
- Group 3 facsimile service (G3 Fax).
- Service negotiation (SN).
- Mobile termination functions.

	Document No.	Version	Status	Issued date	Location
CCSA	CWTS-MC-N.S0008	1.0	Published	-02-2002	http://www.ccsa.org.cn/english/tc/files.php?docpath=/ITU-R/M.1457/M.1457-4/MC
TIA	TIA-737		Published	-- 01-2002	http://www.tiaonline.org/standards/catalog/search.cfm
TTA	TTAE.3G-N.S0008 V1.0	1	Approved	13-07-2000	http://www.tta.or.kr/standardDB/stnfile/TTAE_3G-N.S0008v1.0.pdf
TTC	JP-3GB-N.S0008	1	TTC Published	31-03-2000	http://www.ttc.or.jp/imt2000/std/jpns0008.pdf

10.2.6 N.S0009-0 Version 1.0 IMSI (no date)

	Document No.	Version	Status	Issued date	Location
CCSA	CWTS-MC-N.S0009-0	1.0	Published	-02-2002	http://www.ccsa.org.cn/english/tc/files.php?docpath=/ITU-R/M.1457/M.1457-4/MC
TIA	TIA-751		Published	-- 01-2002	http://www.tiaonline.org/standards/catalog/search.cfm
TTA	TTAE.3G-N.S0009	1	Approved	13-07-2000	http://www.tta.or.kr/standardDB/stnfile/TTAE_3G-N_S0009.zip
TTC	JP-3GB-N.S0009	1	TTC Published	31-03-2000	http://www.ttc.or.jp/imt2000/std/jpns0009.pdf

10.2.7 N.S0010-0 Version 1.0 Advanced features in Wideband Spread Spectrum Systems (no date)

For this revision of this standard, the advanced CDMA features include: network directed system selection (NDSS) and subscriber confidentiality (SC) supported by TMSI.

	Document No.	Version	Status	Issued date	Location
CCSA	CWTS-MC-N.S0010-0	1.0	Published	-02-2002	http://www.ccsa.org.cn/english/tc/files.php?docpath=/ITU-R/M.1457/M.1457-4/MC
TIA	TIA-735		Published	-- 01-2002	http://www.tiaonline.org/standards/catalog/search.cfm
TTA	TTAE.3G-N.S0010 v1.0	1.0	Approved	28-10-2002	http://www.tta.or.kr/standardDB/stnfile/TTAE_3G-N.S0010-0v1.0.pdf
TTC	JP-3GB-N.S0010-0	1	TTC Published	31-03-2000	http://www.ttc.or.jp/imt2000/std/jpns0010.pdf

10.2.8 N.S0011-0 Version 1.0 OTASP and OTAPA (no date)

This document presents recommendations for supporting the over-the-air "service provisioning" (OTASP) and "parameter administration" (OTAPA) capability.

Specifically, this document includes stage 1 recommendations for OTASP subscriber feature and OTAPA network feature descriptions. It also provides intersystem operation recommendations for supporting the OTASP and OTAPA capability for the CDMA and TDMA air interfaces, with

stage 2 operations and scenarios, stage 3 operations and parameter definitions plus stage 3 procedures.

	Document No.	Version	Status	Issued date	Location
CCSA	CWTS-MC-N.S0011-0	1.0	Published	-02-2002	http://www.ccsa.org.cn/english/tc/files.php?docpath=/ITU-R/M.1457/M.1457-4/MC
TIA	TIA/EIA/IS-725-A		Published	-- 07-1999	http://www.tiaonline.org/standards/catalog/search.cfm
TTA	TTAE.3G-N.S0011	1	Approved	13-07-2000	http://www.tta.or.kr/standardDB/stnfile/TTAE_3G-N_S0011.zip
TTC	JP-3GB-N.S0011	1	TTC Published	31-03-2000	http://www.ttc.or.jp/imt2000/std/jpns0011.pdf

10.2.9 N.S0012-0 CNAP/CNAR Revision: 0 (28 January 2000)

This document presents a recommended plan for the implementation of calling name presentation (CNAP) and calling name restriction (CNAR) for use in the wireless radiotelephone service.

	Document No.	Version	Status	Issued date	Location
CCSA	CWTS-MC-N.S0012-0	1.0	Published	-02-2002	http://www.ccsa.org.cn/english/tc/files.php?docpath=/ITU-R/M.1457/M.1457-4/MC
TIA	TIA-764		Published	-- 01-2002	http://www.tiaonline.org/standards/catalog/search.cfm
TTA	TTAE.3G-N.S0012	1	Approved	13-07-2000	http://www.tta.or.kr/standardDB/stnfile/TTAE_3G-N_S0012.zip
TTC	JP-3GB-N.S0012	1	TTC Published	31-03-2000	http://www.ttc.or.jp/imt2000/std/jpns0012.pdf

10.2.10 N.S0013-0 Version 1.0 WIN Phase 1 (no date)

The wireless intelligent network (WIN) is a network which supports the use of intelligent network capabilities to provide seamless terminal services, personal mobility services and advanced network services in mobile environment.

This document presents a recommended plan for the implementation of the wireless intelligent network (WIN) for use in the wireless radiotelephone service.

	Document No.	Version	Status	Issued date	Location
CCSA	CWTS-MC-N.S0013-0	1.0	Published	-02-2002	http://www.ccsa.org.cn/english/tc/files.php?docpath=/ITU-R/M.1457/M.1457-4/MC
TIA	TIA/EIA/IS-771		Published	-- 07-1999	http://www.tiaonline.org/standards/catalog/search.cfm
	TIA/EIA/IS-771-1		Published	-- 08-2001	
TTA	TTAE.3G-N.S0013	1	Approved	13-07-2000	http://www.tta.or.kr/standardDB/stnfile/TTAE_3G-N_S0013.zip
TTC	JP-3GB-N.S0013	1	TTC Published	31-03-2000	http://www.ttc.or.jp/imt2000/std/jpns0013.pdf

10.2.11 N.S0014-0 Version 1.0 Authentication Enhancements (no date)

This standard presents a recommended plan for the implementation of authentication enhancements for use in the wireless radiotelephone service. Its intent is to describe the authentication enhancements so that the manner in which a system implements them may remain reasonably consistent from system to system.

The authentication enhancements include:

- Count update after handoff.
- Obtaining subscriber profile before authentication on initial system access.
- Handling of suspicious call originations.
- Identifying the serving MSC when reporting the outcome of a requested authentication operation.
- Handling of authentication capable mobile stations when the home system is not authentication capable.
- Clarification and editorial correction of authentication procedures.
- Miscellaneous authentication enhancements.

	Document No.	Version	Status	Issued date	Location
CCSA	CWTS-MC-N.S0014-0	1.0	Published	-02-2002	http://www.ccsa.org.cn/english/tc/files.php?docpath=/ITU-R/M.1457/M.1457-4/MC
TIA	TIA/EIA/IS-778		Published	-- 03-1999	http://www.tiaonline.org/standards/catalog/search.cfm
TTA	TTAE.3G-N.S0014	1	Approved	13-07-2000	http://www.tta.or.kr/standardDB/stnfile/TTAE_3G-N_S0014.zip
TTC	JP-3GB-N.S0014	1	TTC Published	31-03-2000	http://www.ttc.or.jp/imt2000/std/jpns0014.pdf

10.2.12 N.S0015 Version 1.0.0 ANSI-41-D Miscellaneous Enhancements (28 January 2000)

This document is intended to justify TIA/EIA-41-D technical enhancement or technical correction contributions that have been supported for incorporation into PN-3590 (TIA/EIA-41-E) but are not expected to be published in a TIA/EIA-41-D enhancement interim standard (IS).

This document is for tracking purposes only, there is no intention of publishing the contents of this document independently of ANSI/TIA/EIA-41-E.

	Document No.	Version	Status	Issued date	Location
CCSA	CWTS-MC-N.S0015	1.0.0	Published	-02-2002	http://www.ccsa.org.cn/english/tc/files.php?docpath=/ITU-R/M.1457/M.1457-4/MC
TTA	TTAE.3G-N.S0015 v1.0.0	1.0.0	Approved	28-10-2002	http://www.tta.or.kr/standardDB/stnfile/TTAE.3G-N.S0015v1.0.0.pdf

10.2.13 N.S0016-0 Version 1.0 TIA/EIA-41-D Internationalization (no date)

This document specifies the ANSI/TIA/EIA-41-D chapter 1, 3, 5 and 6 enhancements that are necessary to support international intersystem operations.

	Document No.	Version	Status	Issued date	Location
CCSA	CWTS-MC-N.S0016-0	1.0	Published	-02-2002	http://www.ccsa.org.cn/english/tc/files.php?docpath=/ITU-R/M.1457/M.1457-4/MC
TIA	TIA/EIA/IS-807 TIA/EIA/IS-807-1		Published Published	-- 08-1999 -- 03-2000	http://www.tiaonline.org/standards/catalog/search.cfm
TTA	TTAE.3G-N.S0016	1	Approved	13-07-2000	http://www.tta.or.kr/standardDB/stnfile/TTAE_3G-N_S0016.zip
TTC	JP-3GB-N.S0016	1	TTC Published	31-03-2000	http://www.ttc.or.jp/imt2000/std/jpns0016.pdf

10.2.14 N.S0017-B Version 1.0.0 International Implementation of Wireless Telecommunication Systems Compliant with TIA/EIA-41 Revision: B (December 2002)

When the first edition of Mobile Station – Land Station Compatibility Specification (IS-3, now TIA/EIA 553-A) was issued, it was envisioned that it would be adopted for use within northern America. Provisions were included for international implementation; however, detailed guidelines to assist with such implementations were not included. Subcommittee TR-45.2 recognized the need to provide such guidance, and chartered a working group (Working Group VI) with this responsibility. The result of this working group's deliberations has been the production of TSB-29 as well as ongoing internationalization of other TIA standards, such as TIA/EIA-41-D (N.S0005), TIA-751 (N.S0009), TIA/EIA/IS-807 (N.S0016), TIA/EIA/IS-875 (N.S0027), TIA/EIA-124 (N.S0026), TIA/EIA-136, IS-95, IS-91 and TIA/EIA-2000 (C.S0001). TSG-N has taken TSB-29 and produced the specification N.S0017.

The principle aspects of international implementation addressed by this document are:

- the administration and assignment of system identification numbers (SIDs);
- the administration and assignment of mobile identification numbers (MINs);
- format of international mobile subscriber identifiers (IMSI).

The goal of this publication is to provide the international wireless telecommunications industry with the framework permitting the coordinated implementation of wireless radio telecommunication systems in compliance with the provisions of the AMPS family of air interface standards (e.g., TIA/EIA-553, IS-54, IS-91, IS-95, TIA/EIA-2000 and TIA/EIA-136).

	Document No.	Version	Status	Issued date	Location
CCSA	CCSA-TSD-MC-N.S0017-0	1.0.0	Approved	09-2003	http://www.ccsa.org.cn/english/tc/files.php?docpath=/ITU-T/Q.1742/R3-2003-11
TIA	TSB-29E		Published	-- 12-2002	http://www.tiaonline.org/standards/catalog/search.cfm
TTA	TTAT.3G-N.S0017-B_v1.0	1.0	Approved	30-10-2003	http://www.tta.or.kr/standardDB/stnfile/TTAT.3G-N.S0017-B_v1.0.zip
TTC	TS-3GB-N.S0017-Bv1.0	1.0	TTC Published	30-05-2003	http://www.ttc.or.jp/imt2000/ts/tsns0017-Bv1.0.pdf

10.2.15 N.S0018 Version 1.0.0 TIA/EIA-41-D Prepaid Charging (14 July 2000)

Pre-Paid Charging (PPC) allows the subscriber to pay for voice telecommunication services prior to usage. This document presents a recommended plan for the implementation of Wireless Intelligent Network (WIN) capabilities that support PPC. The WIN capabilities that support PPC are for use in the Wireless Radiotelephone Service.

	Document No.	Version	Status	Issued date	Location
CCSA	CWTS-MC-N.S0018	1.0.0	Published	-02-2002	http://www.ccsa.org.cn/english/tc/files.php?docpath=/ITU-R/M.1457/M.1457-4/MC
TIA	TIA/EIA/IS-826		Published	-- 09-2000	http://www.tiaonline.org/standards/catalog/search.cfm
TTA	TTAE.3G-N.S0018	1	Approved	13-07-2000	http://www.tta.or.kr/standardDB/stnfile/TTAE.3G-N.S0018.zip
TTC	JP-3GB-N.S0018	2	TTC Published	14-05-2001	http://www.ttc.or.jp/imt2000/std/jpns0018.pdf

10.2.16 N.S0019 Version 1.0.0 Intersystem Link Protocol Revision: 0 (28 January 2000)

This document specifies an intersystem link protocol (ISLP) for circuit-mode data services. These data services include asynchronous data service (ADS) and Group-3 Fax as specified in IS-99 and IS-135. The ISLP adapts between air-interface data rates and higher-speed intersystem rates. The ISLP may be used between a serving system and an anchor system, possibly through one or more tandem systems.

	Document No.	Version	Status	Issued date	Location
CCSA	CWTS-MC-N.S0019	1.0.0	Published	-02-2002	http://www.ccsa.org.cn/english/tc/files.php?docpath=/ITU-R/M.1457/M.1457-4/MC
TIA	TIA-728		Published	-- 01-2002	http://www.tiaonline.org/standards/catalog/search.cfm
TTA	TTAE.3G-N.S0019	1	Approved	13-07-2000	http://www.tta.or.kr/standardDB/stnfile/TTAE_3G-N_S0019.zip
TTC	JP-3GB-N.S0019	1	TTC Published	31-03-2000	http://www.ttc.or.jp/imt2000/std/jpns0019.pdf

10.2.17 N.S0020 TIA/EIA-41-D Message Segmentation (August 1999)

The 3GPP2 document was withdrawn.

10.2.18 N.S0021 Version 1.0.0 User Selective Call Forwarding Revision: 1 (14 July 2000)

This document specifies the wireless intersystem network operation enhancements required for supporting roaming subscribers with the user selective call forwarding (USCF) feature.

	Document No.	Version	Status	Issued date	Location
CCSA	CWTS-MC-N.S0021	1.0.0	Published	-02-2002	http://www.ccsa.org.cn/english/tc/files.php?docpath=/ITU-R/M.1457/M.1457-4/MC
TIA	TIA/EIA/IS-838		Published	-- 07-2000	http://www.tiaonline.org/standards/catalog/search.cfm
TTA	TTAE.3G-N.S0021 v1.0.0	1.0.0	Approved	28-10-2002	http://www.tta.or.kr/standardDB/stnfile/TTAE.3G-N.S0021v1.0.0.pdf
TTC	JP-3GB-N.S0021	1	TTC Published	14-05-2001	http://www.ttc.or.jp/imt2000/std/jpns0021.pdf

10.2.19 N.S0022 Version 1.0.0 Answer Hold (14 July 2000)

This document specifies the wireless intersystem network operation enhancements required for supporting roaming subscribers with the answer hold (AH) feature.

	Document No.	Version	Status	Issued date	Location
CCSA	CWTS-MC-N.S0022	1.0.0	Published	-02-2002	http://www.ccsa.org.cn/english/tc/files.php?docpath=/ITU-R/M.1457/M.1457-4/MC
TIA	TIA/EIA/IS-837		Published	-- 09-2000	http://www.tiaonline.org/standards/catalog/search.cfm
TTA	TTAE.3G-N.S0022 v1.0.0	1.0.0	Approved	28-10-2002	http://www.tta.or.kr/standardDB/stnfile/TTAE.3G-N.S0022v1.0.0.pdf
TTC	JP-3GB-N.S0022	1	TTC Published	14-05-2001	http://www.ttc.or.jp/imt2000/std/jpns0022.pdf

10.2.20 N.S0023-0 Version 1.0 Automatic Code Gapping (no date)

This document presents a recommended plan for the implementation of automatic code gapping (ACG) for use in the wireless radiotelephone service. ACG is used to reduce the rate at which a network entity, typically an MSC, sends service request messages to a session control function (SCF) network entity. ACG controls can be applied automatically by the SCF when it is in overload. ACG controls can also be applied by an SCF for purposes of SCF service management.

	Document No.	Version	Status	Issued date	Location
CCSA	CWTS-MC-N.S0023-0	1.0	Published	-02-2002	http://www.ccsa.org.cn/english/tc/files.php?docpath=/ITU-R/M.1457/M.1457-4/MC
TIA	TIA/EIA/IS-786		Published	-- 11-2000	http://www.tiaonline.org/standards/catalog/search.cfm
TTA	TTAE.3G-N.S0023-0 v1.0	1.0	Approved	28-10-2002	http://www.tta.or.kr/standardDB/stnfile/TTAE.3G-N.S0023-0v1.0.pdf
TTC	JP-3GB-N.S0023	1	TTC Published	14-05-2001	http://www.ttc.or.jp/imt2000/std/jpns0023.pdf

10.2.21 N.S0024-0 Version 1.0 Network support for MDN-Based Message Centres (November 2000)

This document is intended to identify TIA/EIA-41-D wireless number portability Phase III (WNP-PH3) technical enhancements required to support short message service (SMS) delivery to mobile directory number (MDN) based message centres (MCs). These enhancements have been supported for incorporation into PN-3590 (TIA/EIA-41-E) and are being published as a TIA/EIA-41-D enhancement interim standard (IS).

	Document No.	Version	Status	Issued date	Location
CCSA	CWTS-MC-N.S0024-0	1.0	Published	-02-2002	http://www.ccsa.org.cn/english/tc/files.php?docpath=/ITU-R/M.1457/M.1457-4/MC
TIA	TIA/EIA/IS-841		Published	-- 09-2000	http://www.tiaonline.org/standards/catalog/search.cfm
TTA	TTAE.3G-N.S0024-0 v1.0	1.0	Approved	28-10-2002	http://www.tta.or.kr/standardDB/stnfile/TTAE.3G-N.S0024-0v1.0.pdf
TTC	TS-3GB-N.S0024v1.0	1.0	TTC Published	29-08-2001	http://www.ttc.or.jp/imt2000/ts/tsns0024-v10.pdf

10.2.22 N.S0025 Version 1.0.0 Roamer Database Verification (January 2001)

This document presents a recommended plan for the implementation of roamer database verification (RDV) for use in the wireless radiotelephone service. RDV enables a home system to verify that a roaming partner's VLF database is correctly loaded for the MSID number ranges that "belong" to the home service provider. At the request of the HLR, the VLR examines its roamer database to verify that subscribers within the requested MSID range are allowed to roam in the visited system.

RDV provides a tool to assist in resolving problems experienced by home system subscribers when roaming in the visited system.

	Document No.	Version	Status	Issued date	Location
CCSA	CWTS-MC-N.S0025	1.0.0	Published	-02-2002	http://www.ccsa.org.cn/english/tc/files.php?docpath=/ITU-R/M.1457/M.1457-4/MC
TTA	TTAE.3G-N.S0025 v1.0.0	1.0.0	Approved	28-10-2002	http://www.tta.or.kr/standardDB/stnfile/TTAE.3G-N.S0025v1.0.0.pdf
TTC	TS-3GB-N.S0025v1.0	1.0	TTC Published	29-05-2001	http://www.ttc.or.jp/imt2000/ts/tsns0025-v10.pdf

10.2.22.1 N.S0025-A Version 1.0.0 Roamer Database Verification Revision: A (June 2002)

This document presents a recommended plan for the implementation of roamer database verification (RDV) for use in the wireless radiotelephone service.

Several types of network entities (NE) can initiate RDV service queries to verify the contents of databases relating to roaming in other network entities.

RDV enables a home system to verify that a roaming partner's VLF database is correctly loaded for the MSID number ranges that "belong" to the home service provider. At the request of the HLR, the VLR examines its roamer database to verify that subscribers within the requested MSID range are allowed to roam in the visited system.

RDV provides a tool to assist in resolving problems experienced by home system subscribers when roaming in the visited system.

RDV may also be used to verify other message routing databases that may be used to support newer capabilities introduced in IS-41-C or in subsequent intersystem standards, including three message routing databases that may be maintained at an MSC and two message routing databases that may be maintained at an MC.

	Document No.	Version	Status	Issued date	Location
CCSA	CWTS-MC-N.S0025-A	1.0.0	Published	-09-2002	http://www.ccsa.org.cn/english/tc/files.php?docpath=/ITU-T/Q.1742/200306/MC
TIA	TIA/EIA/IS-847-A		Published	-- 07-2002	http://www.tiaonline.org/standards/catalog/search.cfm
TTA	TTAT.3G-N.S0025-A v1.0.0	1.0.0	Approved	21-03-2003	http://www.tta.or.kr/imt2000/TTAT.3G-N.S0025-A v1.0.0.zip

10.2.22.2 N.S0025-B Version 1.0.0 Roamer Database Verification Revision: B (October 2002)

This document presents a recommended plan for the implementation of roamer database verification (RDV) for use in the wireless radiotelephone service.

Several types of network entities (NE) can initiate RDV service queries to verify the contents of databases relating to roaming in other network entities.

RDV enables a home system to verify that a roaming partner's VLF database is correctly loaded for the MSID number ranges that "belong" to the home service provider. At the request of the HLR, the VLR examines its roamer database to verify that subscribers within the requested MSID range are allowed to roam in the visited system.

RDV may also be used to verify other message routing databases that may be used to support newer capabilities introduced in IS-41-C or in subsequent intersystem standards, including three message routing databases that may be maintained at an MSC and two message routing databases that may be maintained at an MC.

RDV provides a tool to assist in resolving problems experienced by home system subscribers when roaming in the visited system as well as other message routing database related problems.

This document describes the RDV network capability and the intersystem operations to enable a wireless system to use RDV.

	Document No.	Version	Status	Issued date	Location
CCSA	CCSA-TSD-MC-N.S0025-B	1.0.0	Approved	09-2003	http://www.ccsa.org.cn/english/tc/files.php?docpath=/ITU-T/Q.1742/R3-2003-11
TTA	TTAT.3G-N.S0025-B_v1.0	1.0	Approved	30-10-2003	http://www.tta.or.kr/standardDB/stnfile/TTAT.3G-N.S0025-B_v1.0.zip

10.2.23 N.S0026 Version 1.0.0 Wireless Radio Telecommunication Intersystem Non-Signaling Data Communication DMH (August 2000)

This standard is complementary to the ANSI-41, cellular radiotelecommunications intersystem operations, series of standards and identifies wireless services specifically involving non-signalling data communications which require intersystem cooperation, presents the general background against which those services are to be provided, and summarizes the principle considerations which have governed and directed the particular approaches taken in the procedural recommendations.

This standard describes the messages and procedures required to perform call detail record data transmission between systems.

	Document No.	Version	Status	Issued date	Location
CCSA	CWTS-MC-N.S0026	1.0.0	Published	-02-2002	http://www.ccsa.org.cn/english/tc/files.php?docpath=/ITU-R/M.1457/M.1457-4/MC
TIA	TIA/EIA-124-C		Published	-- 09-2000	http://www.tiaonline.org/standards/catalog/search.cfm
TTA	TTAE.3G-N.S0026 v1.0.0	1.0.0	Approved	28-10-2002	http://www.tta.or.kr/standardDB/stnfile/TTAE.3G-N.S0026v1.0.0.pdf

10.2.23.1 N.S0026-A Version 1.0.0 Wireless Radio Telecommunication Intersystem Non-Signaling Data Communication DMH Revision A (December 2001)

This standard is complementary to the ANSI-41, cellular radiotelecommunications intersystem operations, series of standards and identifies wireless services specifically involving non-signalling data communications which require intersystem cooperation, presents the general background against which those services are to be provided, and summarizes the principle considerations which have governed and directed the particular approaches taken in the procedural recommendations.

This standard describes the messages and procedures required to perform call detail record data transmission between systems.

	Document No.	Version	Status	Issued date	Location
CCSA	CCSA-TSD-MC-N.S0026-A	1.0.0	Approved	09-2003	http://www.ccsa.org.cn/english/tc/files.php?docpath=/ITU-T/Q.1742/R3-2003-11
TIA	TIA/EIA-124-D		Published	-- 12-2001	http://www.tiaonline.org/standards/catalog/search.cfm
TTA	TTAT.3G-N.S0026-A_v1.0	1.0	Approved	30-10-2003	http://www.tta.or.kr/standardDB/stnfile/TTAT.3G-N.S0026-A_v1.0.zip

10.2.24 N.S0027 Version 1.0.0 Enhanced International Dialing, Calling Number Identification & Callback, Calling Party Category Identification (April 2001)

This document presents a recommended plan for the implementation of enhanced international dialling, calling number identification and callback, and calling party category identification for use in the wireless radiotelephone service.

	Document No.	Version	Status	Issued date	Location
CCSA	CWTS-MC-N.S0027	1.0.0	Published	-02-2002	http://www.ccsa.org.cn/english/tc/files.php?docpath=/ITU-R/M.1457/M.1457-4/MC
TIA	TIA/EIA/IS-875		Published	-- 05-2001	http://www.tiaonline.org/standards/catalog/search.cfm
TTA	TTAE.3G-N.S0027 v1.0.0	1.0.0	Approved	28-10-2002	http://www.tta.or.kr/standardDB/stnfile/TTAE.3G-N.S0027v1.0.0.pdf
TTC	TS-3GB-N.S0027v1.0	1.0	TTC Published	29-05-2001	http://www.ttc.or.jp/imt2000/ts/tsns0027-v10.pdf

10.2.25 N.S0028 Version 1.0.0 Network Interworking Between GSM MAP and ANSI-41 MAP Rev. B Revision: 0 (April 2002)

The 3GPP2 document was superseded by X.S0023-B v1.0.

10.2.26 N.S0029 Version 1.0.0 TIA/EIA-41-D Based Network Enhancements for CDMA Packet Data Service (C-PDS), Phase 1 Revision: 0 (June 2002)

This document specifies the wireless intersystem network operation enhancements required for supporting roaming subscribers with packet data service.

	Document No.	Version	Status	Issued date	Location
CCSA	CWTS-MC-N.S0029	1.0.0	Published	-12-2002	http://www.ccsa.org.cn/english/tc/files.php?docpath=/ITU-T/Q.1742/200306/MC
TIA	TIA/EIA-IS-880		Published	-- 07-2002	http://www.tiaonline.org/standards/catalog/search.cfm
TTA	TTAT.3G-N.S0029-0 v1.0	1.0	Approved	21-03-2003	http://www.tta.or.kr/imt2000/TTAT.3G-N.S0029-0 v1.0.zip
TTC	TS-3GB-N.S0029-0v1.0	1.0	TTC Published	27-08-2002	http://www.ttc.or.jp/imt2000/ts/tsns0029-0v10.pdf

10.2.27 N.S0030 Version 1.0.0 Enhanced Wireless 9-1-1 Phase 2 Revision: 0 (April 2002)

The 3GPP2 document was withdrawn.

10.3 Packet data specifications

10.3.1 P.S0001-A Version 3.0.0 Wireless IP Network Standard (16 July 2001)

This standard defines requirements for support of wireless packet data networking capability on a third generation wireless system based on cdma2000. This specification is based on P.R0001; cdma2000 wireless IP network architecture based on IETF protocols.

This standard defines the two methods for accessing public networks (Internet) and private networks (intranets): simple IP and mobile IP, and the required quality of service and accounting support. IETF protocols are widely employed whenever possible to minimize the number of new protocols required and to maximize the utilization of well accepted standards and hence the speed to market. Reference to the required IETF protocols is provided in section 3 of this standard.

	Document No.	Version	Status	Issued date	Location
CCSA	CWTS-MC-P.S0001-A	3.0.0	Published	-02-2002	http://www.ccsa.org.cn/english/tc/files.php?docpath=/ITU-R/M.1457/M.1457-4/MC
TIA	TIA/EIA/IS-835-A		Published	-- 05-2001	http://www.tiaonline.org/standards/catalog/search.cfm
TTA	TTAE.3G-P.S0001-A v3.0.0	3.0.0	Approved	28-10-2002	http://www.tta.or.kr/standardDB/stnfile/TTAE.3G-P.S0001-Av3.0.0.pdf
TTC	TS-3GB-P.S0001-Av3.0	3.0	TTC Published	29-08-2001	http://www.ttc.or.jp/imt2000/ts/tsps0001-A-v30.pdf

10.3.2 P.S0001-B Version 1.0.0 Wireless IP Network Standard (25 October 2002)

The 3GPP2 document was superseded by X.S0011-C.

10.3.3 P.S0001-B Version 2.0 cdma2000 Wireless IP Network Standard (September 2004)

The 3GPP2 document was superseded by X.S0011-C.

10.4 Services and system aspects specifications

10.4.1 S.R0003 Version 1.0.0 3GPP2 System Capability Guide Release A (20 January 2000)

The 3GPP2 document is re-numbered as SC.R2001-001 v1.0

10.4.1.1 S.R0003-A Version 1.0 3GPP2 System Capability Guide Release B (14 June 2001)

This document is re-numbered as SC.R2002-001 v1.0

10.4.2 S.R0004 Version 1.0.0 Service Implementation Guide Revision: 0 (20 January 2000)

This service implementation document describes and defines features adopted by 3GPP2 TSG-S. The features descriptions may include both stage 1 and stage 2 functional levels.

	Document No.	Version	Status	Issued date	Location
CCSA	CWTS-MC-S.R0004	1.0.0	Published	-02-2002	http://www.ccsa.org.cn/english/tc/files.php?docpath=/ITU-R/M.1457/M.1457-4/MC
TTA	TTAE.3G-S.R0004v1.0.0	1.0.0	Approved	28-10-2002	http://www.tta.or.kr/standardDB/stnfile/TTAE.3G-S.R0004v1.0.0.pdf

10.4.3 S.R0005-B Version 1.0 Network Reference Model for cdma2000 Spread Spectrum Systems Revision: B (16 April 2001)

This document recommends the basic 3GPP2 wireless network reference model.

	Document No.	Version	Status	Issued date	Location
CCSA	CWTS-MC-S.R0005-B	1.0	Published	-02-2002	http://www.ccsa.org.cn/english/tc/files.php?docpath=/ITU-R/M.1457/M.1457-4/MC
TIA	TSB-100-A		Published	-- 03-2001	http://www.tiaonline.org/standards/catalog/search.cfm
TTA	TTAE.3G-S.R0005-B	1	Approved	19-12-2001	http://www.tta.or.kr/standardDB/stnfile/TTAE_3G-S_R0005-B.zip
TTC	TS-3GB-S.R0005-Bv1.0	1.0	TTC Published	29-05-2001	http://www.ttc.or.jp/imt2000/ts/tssr0005-B-v10.pdf

10.4.4 S.R0006 Version 1.0.0 Wireless Features Description Revision: 0 (13 December 1999)

This standard presents a recommended plan for the implementation of uniform features for use in the wireless radiotelephone service. Its intent is to describe services and features so that the manner in which a subscriber may place calls using such features and services may remain reasonably consistent from system to system. It is not intended that specific service offerings be required of all service providers.

	Document No.	Version	Status	Issued date	Location
CCSA	CWTS-MC-S.R0006	1.0.0	Published	-02-2002	http://www.ccsa.org.cn/english/tc/files.php?docpath=/ITU-R/M.1457/M.1457-4/MC
TIA	TIA/EIA-664-A		Published	-- 12-2000	http://www.tiaonline.org/standards/catalog/search.cfm
TTA	TTAE.3G-S.R0006 v1.0.0	1.0.0	Approved	28-10-2002	http://www.tta.or.kr/standardDB/stnfile/TTAE.3G-S.R0006v1.0.0.pdf
TTC	JP-3GB-S.R0006	1	TTC Published	31-03-2000	http://www.ttc.or.jp/imt2000/std/jpsr0006.pdf

10.4.5 S.R0007 Version 1.0.0 User Selective Call Forwarding (Stage 1) Revision: 0 (13 December 1999)

This interim standard (IS) presents stage 1 (new chapter TIA/EIA-664-B), stage 2 (TIA/EIA-41.3-D enhancements), and stage 3 (TIA/EIA-41.5-D and TIA/EIA-41.6-D enhancements) recommendations for supporting the user selective call forwarding (USCF) feature use in the wireless radiotelephone service.

This document specifies the wireless intersystem network operation enhancements required for supporting roaming subscribers with the user selective call forwarding (USCF) feature.

	Document No.	Version	Status	Issued date	Location
CCSA	CWTS-MC-S.R0007	1.0.0	Published	-02-2002	http://www.ccsa.org.cn/english/tc/files.php?docpath=/ITU-R/M.1457/M.1457-4/MC
TTA	TTAE.3G-S.R0007 v.1.0	1.0	Approved	19-12-2001	http://www.tta.or.kr/standardDB/stnfile/TTAE_3G-S_R0007 v1.0.zip

10.4.5.1 S.R0007 Version 2.1 User Selective Call Forwarding (Stage 1) (31 January 2001)

This interim standard (IS) presents stage 1 (new chapter TIA/EIA-664-B), stage 2 (TIA/EIA-41.3-D enhancements), and stage 3 (TIA/EIA-41.5-D and TIA/EIA-41.6-D enhancements) recommendations for supporting the user selective call forwarding (USCF) feature use in the wireless radiotelephone service.

This document specifies the wireless intersystem network operation enhancements required for supporting roaming subscribers with the user selective call forwarding (USCF) feature.

	Document No.	Version	Status	Issued date	Location
CCSA	CWTS-MC-S.R0007 v2.1	2.1	Published	-02-2002	http://www.ccsa.org.cn/english/tc/files.php?docpath=/ITU-R/M.1457/M.1457-4/MC
TTA	TTAE.3G-S.R0007 v.2.1	2.1	Approved	19-12-2001	http://www.tta.or.kr/standardDB/stnfile/TTAE_3G-S_R0007 v2.1.zip
TTC	TS-3GB-S.R0007v2.1	2.1	TTC Published	29-05-2001	http://www.ttc.or.jp/imt2000/ts/tssr0007-v21.pdf

10.4.6 S.R0008 Version 1.0.0 Answer Hold (Stage 1) Revision: 0 (13 December 1999)

This interim standard (IS) presents stage 1 (new chapter TIA/EIA-664-B), stage 2 (TIA/EIA-41.3-D enhancements), and stage 3 (TIA/EIA-41.5-D and TIA/EIA-41.6-D enhancements) recommendations for supporting the answer hold (AH) feature use in the wireless radiotelephone service.

This document specifies the wireless intersystem network operation enhancements required for supporting roaming subscribers with the answer hold (AH) feature.

	Document No.	Version	Status	Issued date	Location
CCSA	CWTS-MC-S.R0008	1.0	Published	-02-2002	http://www.ccsa.org.cn/english/tc/files.php?docpath=/ITU-R/M.1457/M.1457-4/MC
TTA	TTAE.3G-S.R0008 V.1.0	1.0	Approved	19-12-2001	http://www.tta.or.kr/standardDB/stnfile/TTAE_3G-S_R0008_v1.0.zip

10.4.6.1 S.R0008 Version 2.0 Answer Hold (Stage 1) Revision: 0 (8 December 2000)

This interim standard (IS) presents stage 1 (new chapter TIA/EIA-664-B), stage 2 (TIA/EIA-41.3-D-enhancements), and stage 3 (TIA/EIA-41.5-D and TIA/EIA-41.6-D enhancements) recommendations for supporting the answer hold (AH) feature use in the wireless radiotelephone service.

This document specifies the wireless intersystem network operation enhancements required for supporting roaming subscribers with the answer hold (AH) feature.

	Document No.	Version	Status	Issued date	Location
CCSA	CWTS-MC-S.R0008 v2.1	v2.0	Published	-02-2002	http://www.ccsa.org.cn/english/tc/files.php?docpath=/ITU-R/M.1457/M.1457-4/MC
TTA	TTAE.3G-S.R0008 V.2.0	2.0	Approved	19-12-2001	http://www.tta.or.kr/standardDB/stnfile/TTAE_3G-S_R0008_v2.0.zip
TTC	JP-3GB-S.R0008	2	TTC Published	14-05-2001	http://www.ttc.or.jp/imt2000/std/jpsr0008.pdf

10.4.7 S.R0009-0 v1.0 User Identity Module (Stage 1) Revision: 0 (13 December 1999)

This standard defines the enhancements required for the support of mobile stations equipped with user identification modules (UIMs). The UIM provides functionality to certain types of mobile stations to enable them to operate in the wireless network.

This document defines requirements for the wireless network to support operation of UIM-equipped mobile stations. A UIM provides compatible mobile stations with the parameters required of mobile stations operating in the TIA/EIA-41 environment and specific additional functionality unique to UIM-equipped mobile stations.

The UIM can be in one of two forms: as either integrated within the mobile, or removable that can be inserted or removed from the mobile equipment. This document addresses removable UIM (R-UIM) only.

	Document No.	Version	Status	Issued date	Location
CCSA	CWTS-MC-S.R0009-0	1.0	Published	-02-2002	http://www.ccsa.org.cn/english/tc/files.php?docpath=/ITU-R/M.1457/M.1457-4/MC
TTA	TTAE.3G-S.R0009	1	Approved	13-07-2000	http://www.tta.or.kr/standardDB/stnfile/TTAE_3G-S_R0009.zip
TTC	TS-3GB-S.R0009	1	TTC Published	29-05-2001	http://www.ttc.or.jp/imt2000/ts/tssr0009-v10.pdf

10.4.8 S.R0010 Version 1.0.0 Preferred Language (Stage 1) Revision: 0 (13 December 1999)

Preferred language (PL) provides the subscriber the ability to specify the language for network services.

Network services which could be offered in the subscriber's preferred language include:

- recorded announcements;
- directory assistance;
- operator services;
- emergency services;
- "Help" lines;
- message waiting notification;
- CNIP number not available; and
- CNIP number restricted.

If the subscriber's preferred language is not available, service shall be provided in the default language, which shall be determined by the wireless network operator.

PL does not impact a subscriber's ability to originate calls or to receive calls.

	Document No.	Version	Status	Issued date	Location
CCSA	CWTS-MC-S.R0010	1.0.0	Published	-02-2002	http://www.ccsa.org.cn/english/tc/files.php?docpath=/ITU-R/M.1457/M.1457-4/MC
TTA	TTAE.3G-S.R0010	1	Approved	13-07-2000	http://www.tta.or.kr/standardDB/stnfile/TTAE_3G-S_R0010.zip
TTC	JP-3GB-S.R0010	1	TTC Published	31-03-2000	http://www.ttc.or.jp/imt2000/std/jpsr0010.pdf

10.4.9 S.R0011 Version 1.0.0 Advice of Charge (Stage 1) Revision: 0 (13 December 1999)

This specification presents stage 1 for supporting the advice of charge feature for use in the wireless radiotelephone service.

This document specifies the wireless intersystem network operation enhancements required for supporting roaming subscribers with the advice of charge (AoC) feature.

	Document No.	Version	Status	Issued date	Location
CCSA	CWTS-MC-S.R0011	1.0.0	Published	-02-2002	http://www.ccsa.org.cn/english/tc/files.php?docpath=/ITU-R/M.1457/M.1457-4/MC
TTA	TTAE.3G-S.R0011	1	Approved	13-07-2000	http://www.tta.or.kr/standardDB/stnfile/TTAE_3G-S_R0011.zip
TTC	JP-3GB-S.R0011	1	TTC Published	31-03-2000	http://www.ttc.or.jp/imt2000/std/jpsr0011.pdf

10.4.10 S.R0012 Version 1.0.0 Rejection of Undesired Annoying Calls (Stage 1) Revision: 0 (13 December 1999)

This specification presents stage 1 for supporting rejection of undesired annoying calls feature for use in the wireless radiotelephone service.

This document specifies the wireless intersystem network operation enhancements required for supporting roaming subscribers with the rejection of undesired annoying calls (RUAC) feature.

	Document No.	Version	Status	Issued date	Location
CCSA	CWTS-MC-S.R0012	1.0.0	Published	-02-2002	http://www.ccsa.org.cn/english/tc/files.php?docpath=/ITU-R/M.1457/M.1457-4/MC
TTA	TTAE.3G-S.R0012	1	Approved	13-07-2000	http://www.tta.or.kr/standardDB/stnfile/TTAE_3G-S_R0012.zip
TTC	JP-3GB-S.R0012	1	TTC Published	31-03-2000	http://www.ttc.or.jp/imt2000/std/jpsr0012.pdf

10.4.11 S.R0013 Version 1.0.0 Global Emergency Call Origination (GECO) Revision: 0 (13 December 1999)

This document presents a stage 1 description for a global emergency call origination (GECO) which will increase the probability that any user can originate a call to a public service access point (PSAP) even in those service areas where the emergency service access number (ESAN) is not known to the user.

The intent of GECO is described as follows:

- The MS may provide a means for the user to initiate an emergency call.
- A special form of the call origination message (defined as a global emergency call origination message (GECO_MSG)) may be issued by the MS in lieu of the normal call origination message to indicate that the call origination being requested is an emergency call origination. GECO_MSGs may be accepted and the GECO call connected by the network from both subscribed and unsubscribed mobiles. The system may support "implicit registration" for GECO calls such that the use of registration request/acceptance protocol is not required prior to the issuance of a GECO_MSG.
- If the MS is currently registered on and accessing an operating network when the GECO call is initiated by the user, the MS may use that system to initiate the GECO call. If the MS is not currently accessing a system, the MS may attempt to access its preferred service as indicated by its internal system selection and system access restriction programming to maximize the probability that the GECO call will be accepted by the system. If no preferred system is available, the MS may override its internal system selection and system access restriction programming in an attempt to access any available system.
- Initiation of a GECO call by the MS shall in no way degrade the user's access to any other feature/service which would normally be available to him from the accessed service provider's network.

	Document No.	Version	Status	Issued date	Location
CCSA	CWTS-MC-S.R0013	1.0.0	Published	-02-2002	http://www.ccsa.org.cn/english/tc/files.php?docpath=/ITU-R/M.1457/M.1457-4/MC
TTA	TTAE.3G-S.R0013	1	Approved	13-07-2000	http://www.tta.or.kr/standardDB/stnfile/TTAE_3G-S_R0013.zip
TTC	JP-3GB-S.R0013	1	TTC Published	31-03-2000	http://www.ttc.or.jp/imt2000/std/jpsr0013.pdf

10.4.12 S.R0014 Version 1.0.0 Tandem Free Operation (Stage 1) Revision: 0 (13 December 1999)

It is expected that the need for tandem free operations will be driven by the increasing market penetration of digital technologies which will result in an increase in percentage of mobile-to-mobile calls. In addition, given that the effects of tandem vocoding are greater for lower bit rate vocoders, the need for this feature becomes greater as the use of low bit rate vocoders increases. The tandem free operation (TFO) feature, also known as vocoder bypass, improves the end-to-end voice quality observed in mobile-to-mobile voice calls in wireless networks.

	Document No.	Version	Status	Issued date	Location
CCSA	CWTS-MC-S.R0014	1.0.0	Published	-02-2002	http://www.ccsa.org.cn/english/tc/files.php?docpath=/ITU-R/M.1457/M.1457-4/MC
TTA	TTAE.3G-S.R0014	1	Approved	13-07-2000	http://www.tta.or.kr/standardDB/stnfile/TTAE_3G-S_R0014.zip
TTC	JP-3GB-S.R0014	1	TTC Published	31-03-2000	http://www.ttc.or.jp/imt2000/std/jpsr0014.pdf

10.4.13 S.R0015 Version 1.0.0 ISDN Interworking (Stage 1) Release A (13 December 1999)

This document presents stage 1 (new chapter TIA/EIA-664-B) recommendations for supporting the ISDN interworking feature use in wireless radiotelephone service.

This document specifies the wireless intersystem network operation enhancements required for supporting subscribers with the ISDN interworking feature. This document defines the functional characteristics for interconnecting to ISDN in circuit-switched mode. The interworking function in ISDN packet mode, i.e., B-channel packet is out of scope at present.

	Document No.	Version	Status	Issued date	Location
CCSA	CWTS-MC-S.R0015	1.0.0	Published	-02-2002	http://www.ccsa.org.cn/english/tc/files.php?docpath=/ITU-R/M.1457/M.1457-4/MC
TTA	TTAE.3G-S.R0015	1	Approved	13-07-2000	http://www.tta.or.kr/standardDB/stnfile/TTAE_3G-S_R0015.zip
TTC	JP-3GB-S.R0015	1	TTC Published	31-03-2000	http://www.ttc.or.jp/imt2000/std/jpsr0015.pdf

10.4.14 S.R0016 Version 1.0.0 Automatic Code Gapping (Stage 1) Revision: 0 (13 December 1999)

Automatic code gapping (ACG) is intended to provide a network entity, such as a service control point (SCP) or session control function (SCF), the ability to turn off selected types of traffic that may be passing through its domain of operation. The purpose for ACG may be load-related or in response to a traffic engineering command as from a service management system (SMS). This report provides a general description of ACG as it applies to 3G network operations. Specific applications will be defined in other documents or later versions of this document.

	Document No.	Version	Status	Issued date	Location
CCSA	CWTS-MC-S.R0016	1.0.0	Published	-02-2002	http://www.ccsa.org.cn/english/tc/files.php?docpath=/ITU-R/M.1457/M.1457-4/MC
TTA	TTAE.3G-S.R0016 V.1.0	1.0	Approved	19-12-2001	http://www.tta.or.kr/standardDB/stnfile/TTAE_3G-S_R0016.zip

10.4.14.1 S.R0016 Version 2.0 Automatic Code Gapping (Stage 1) Revision: 0 (8 December 2000)

Automatic code gapping (ACG) is intended to provide a network entity, such as a service control point (SCP) or session control function (SCF), the ability to turn off selected types of traffic that may be passing through its domain of operation. The purpose for ACG may be load-related or in response to a traffic engineering command as from a service management system (SMS). This report provides a general description of ACG as it applies to 3G network operations. Specific applications will be defined in other documents or later versions of this document.

	Document No.	Version	Status	Issued date	Location
CCSA	CWTS-MC-S.R0016 v2.0	2.0	Published	-02-2002	http://www.ccsa.org.cn/english/tc/files.php?docpath=/ITU-R/M.1457/M.1457-4/MC
TTA	TTAE.3G-S.R0016 V.2.0	2.0	Approved	19-12-2001	http://www.tta.or.kr/standardDB/stnfile/TTAE_3G-S_R0016_v2.0.zip
TTC	JP-3GB-S.R0016	2	TTC Published	14-05-2001	http://www.ttc.or.jp/imt2000/std/jpsr0016.pdf

10.4.15 S.R0017 3G Wireless Network Management System High Level Requirements Revision: 0 (13 December 1999)

This report specifies the 3G wireless network management system high level requirements including: OAM&P TMN applications required network and systems management processes and network reference model (NRM)

	Document No.	Version	Status	Issued date	Location
CCSA	CWTS-MC-S.R0017		Published	-02-2002	http://www.ccsa.org.cn/english/tc/files.php?docpath=/ITU-R/M.1457/M.1457-4/MC
TTA	TTAE.3G-S.R0017	1	Approved	13-07-2000	http://www.tta.or.kr/standardDB/stnfile/TTAE_3G-S_R0017.zip
TTC	TR-3GB-S.R0017-0v1.0	1.0	TTC Published	26-02-2002	http://www.ttc.or.jp/imt2000/tr/trsr0017-0v10.pdf

10.4.16 S.R0018 Version 1.0.0 Pre-Paid Charging (Stage 1) Revision: 0 (13 December 1999)

PPC allows the subscriber to pay for voice telecommunication services prior to usage.

A PPC subscriber establishes an account with the service provider to access voice telecommunication services in home and roaming networks. Charges for voice telecommunication services are applied to the PPC account by decrementing the account in real time. The PPC subscriber may be notified about the account information at the beginning, during, or at the end of the voice telecommunications service. When the account balance is low the subscriber may be notified so that the subscriber may refill the account. When the account balance is below a pre-defined threshold, the subscriber's use of voice telecommunications services may be de-authorized.

	Document No.	Version	Status	Issued date	Location
CCSA	CWTS-MC-S.R0018	1.0.0	Published	-02-2002	http://www.ccsa.org.cn/english/tc/files.php?docpath=/ITU-R/M.1457/M.1457-4/MC
TTA	TTAE.3G-S.R0018	1	Approved	13-07-2000	http://www.tta.or.kr/standardDB/stnfile/TTAE_3G-S_R0018.zip
TTC	JP-3GB-S.R0018	1	TTC Published	31-03-2000	http://www.ttc.or.jp/imt2000/std/jpsr0018.pdf

10.4.17 S.R0019 Version 1.0.0 Location-Based Services System (LBSS) Stage 1 Description (22 September 2000)

This document defines LBSS for implementation in 3GPP2 systems. The location services functionality has been adopted from existing TR-45 standards as defined and also as described within the document.

The scope of this document includes 3GPP2 system support required to facilitate location-based services.

	Document No.	Version	Status	Issued date	Location
CCSA	CWTS-MC-S.R0019	1.0.0	Published	-02-2002	http://www.ccsa.org.cn/english/tc/files.php?docpath=/ITU-R/M.1457/M.1457-4/MC
TTA	TTAE.3G-S.R0019 v1.0.0	1.0.0	Approved	28-10-2002	http://www.tta.or.kr/standardDB/stnfile/TTAE.3G-S.R0019v1.0.0.pdf
TTC	JP-3GB-S.R0019	1	TTC Published	14-05-2001	http://www.ttc.or.jp/imt2000/std/jpsr0019.pdf

10.4.18 S.R0021 Version 1.0 Video Streaming Service – Stage 1 (10 July 2000)

The objective is to define and to standardize the functionality of video services that can be incorporated into the operations of wireless telecommunication networks. Audio-only streaming is a special case of video streaming. This document defines the functional characteristics and requirements of the video streaming services. The areas that must be defined are service features and system requirements, necessary for video streaming services to be provided in wireless telecommunication networks.

	Document No.	Version	Status	Issued date	Location
CCSA	CWTS-MC-S.R0021	1.0	Published	-02-2002	http://www.ccsa.org.cn/english/tc/files.php?docpath=/ITU-R/M.1457/M.1457-4/MC
TTA	TTAE.3G-S.R0021 v1.0	1.0	Approved	28-10-2002	http://www.tta.or.kr/standardDB/stnfile/TTAE.3G-S.R0021v1.0.pdf
TTC	JP-3GB-S.R0021	1	TTC Published	14-05-2001	http://www.ttc.or.jp/imt2000/std/jpsr0021.pdf

10.4.18.1 S.R0021 Version 2.0 Multimedia Streaming Service – Stage 1 (18 April 2002)

The objective is to define and to standardize the functionality of multimedia services that can be incorporated into the operations of wireless telecommunication networks. Audio-only or video-only streaming are a special case of multimedia streaming. This document defines the functional characteristics and requirements of the multimedia streaming services. The areas that must be defined are service features and system requirements, necessary for multimedia streaming services to be provided in wireless telecommunication networks.

	Document No.	Version	Status	Issued date	Location
CCSA	CCSA-TSD-MC-S.R0021	2.0	Approved	09-2003	http://www.ccsa.org.cn/english/tc/files.php?docpath=/ITU-T/Q.1742/R3-2003-11
TTA	TTAT.3G-S.R0021-0_v2.0	2.0	Approved	30-10-2003	http://www.tta.or.kr/standardDB/stnfile/TTAT.3G-S.R0021-0_v2.0.zip
TTC	TS-3GB-S.R0021-0v2.0	2.0	TTC Published	27-08-2002	http://www.ttc.or.jp/imt2000/ts/tssr0021-0v20.pdf

10.4.19 S.R0022 Version 1.0 Video Conferencing Service – Stage 1 (10 July 2000)

The objective is to define and to standardize the functionality of video services that can be incorporated into the operations of wireless telecommunication networks. This report defines the functional characteristics and the requirements of the video conferencing services. The areas that must be defined are service features and system requirements in order for voice conferencing services to be provided in wireless telecommunication networks.

	Document No.	Version	Status	Issued date	Location
CCSA	CWTS-MC-S.R0022	1.0	Published	-02-2002	http://www.ccsa.org.cn/english/tc/files.php?docpath=/ITU-R/M.1457/M.1457-4/MC
TTA	TTAE.3G-S.R0022 v1.0	1.0	Approved	28-10-2002	http://www.tta.or.kr/standardDB/stnfile/TTAE.3G-.R0022v1.0.pdf
TTC	JP-3GB-S.R0022	1	TTC Published	14-05-2001	http://www.ttc.or.jp/imt2000/std/jpsr0022.pdf

10.4.20 S.R0023 Version 1.0 High-Speed Data Enhancements for cdma2000 1x – Data Only (9 June 2000)

This document outlines the key operator requirements for the evolution of the cdma2000 1x (current versions of C.S0001 through C.S0005) standard. This document will refer to this evolution as 1x evolved high-speed data only (1xEVDO). These requirements are defined to drive improvements to the fundamental packet data capabilities and efficiencies of cdma2000 1x systems to better meet the rapidly evolving needs of subscribers. This report is intended as a guide for wireless operators in the implementation of high-speed data-only systems beyond cdma2000 1x, to provide increased spectral efficiency and the capability to satisfy customer demand for wireless packet data applications.

	Document No.	Version	Status	Issued date	Location
CCSA	CWTS-MC-S.R0023	1.0	Published	-02-2002	http://www.ccsa.org.cn/english/tc/files.php?docpath=/ITU-R/M.1457/M.1457-4/MC
TTA	TTAE.3G-S.R0023 v1.0	1.0	Approved	28-10-2002	http://www.tta.or.kr/standardDB/stnfile/TTAE.3G-.R0023v1.0.pdf

10.4.20.1 S.R0023 Version 2.0 High-Speed Data Enhancements for cdma2000 1x – Data Only Stage 1 Requirements (5 December 2000)

This document outlines the key operator requirements for the evolution of the cdma2000 1x (current versions of C.S0001 through C.S0005) standard. This document will refer to this evolution as 1x evolved high-speed data only (1xEVDO). These requirements are defined to drive improvements to the fundamental packet data capabilities and efficiencies of cdma2000 1x systems to better meet the rapidly evolving needs of subscribers. This report is intended as a guide for wireless operators in the implementation of high-speed data-only systems beyond cdma2000 1x, to provide increased spectral efficiency and the capability to satisfy customer demand for wireless packet data applications.

	Document No.	Version	Status	Issued date	Location
ARIB	TR-T13-S.R0023 v2.0	2.0	ARIB Published	29-07-2003	http://www.arib.or.jp/IMT-2000/ARIB-STD/ITU-T/ARIB_ITU-T_Q.1742/ARIB_TR-T13-S.R0023_V2.PDF
CCSA	CWTS-MC-S.R0023 v2.0	2.0	Published	-02-2002	http://www.ccsa.org.cn/english/tc/files.php?docpath=/ITU-R/M.1457/M.1457-4/MC
TTA	TTAE.3G-S.R0023 v.2.0	2.0	Approved	19-12-2001	http://www.tta.or.kr/standardDB/stnfile/TTAE_3G-S_R0023_v2.0.zip

10.4.21 S.R0024 Version 1.0 Wireless Local Loop – Stage 1 Description (22 September 2000)

Wireless local loop (WLL) is a feature implementation using a serving system that utilizes a wireless connection to a wireless device, such as a mobile station or a network interface unit, to provide local loop service to an end user. WLL permits local loop service for subscriber call origination and for receipt of calls. WLL applies to voice and data services. WLL provides signalling mechanisms between the serving system and the mobile station or the network interface unit. This signalling mechanism permits the exchange of call control information.

The essential signalling elements of WLL are:

- Mobile station or network interface unit device type specification and request for WLL of the serving system or optional serving system device type specification.
- Mobile station or network interface unit dial tone or optional dial tone of the serving system.
- Mobile station or network interface unit hook status enabling WLL call control of the serving system.
- Serving system autonomous message interval specification and request of the mobile station or the network interface unit or optional network interface unit autonomous message interval specification.
- Serving system call waiting indicator notification to the mobile station or the network interface unit.

	Document No.	Version	Status	Issued date	Location
CCSA	CWTS-MC-S.R0024	1.0	Published	-02-2002	http://www.ccsa.org.cn/english/tc/files.php?docpath=/ITU-R/M.1457/M.1457-4/MC
TTA	TTAE.3G-S.R0024 v1.0	1.0	Approved	28-10-2002	http://www.tta.or.kr/standardDB/stnfile/TTAE.3G-S.R0024v1.0.pdf

10.4.22 S.R0025 Version 1.0 Wireless Pay Phone – Stage 1 Description (22 September 2000)

Wireless pay phone is a public telecommunication service feature that allows mobile station support of pay phone applications. The wireless pay phone feature is useful to subscribers that originate or receive calls at a pay phone.

The feature may be comprised of two signalling capabilities. The first signalling capability is that which allows a serving system to convey answer supervision. The second signalling capability is that which allows a serving system to meter calls.

NOTE – A serving system may convey answer supervision using alert-signalled or flash-signalled line control. A serving system may meter using alert-signalled or flash-signaled meter pulses.

Answer element of supervision is used by the mobile station to convey line polarity, which is useful as an answer supervision indication. Line control specification and notification of the mobile station enables specification of polarity included, toggle mode, reverse polarity and power denial time. These are specified in IS-95B section 7.7.5.15.

	Document No.	Version	Status	Issued date	Location
CCSA	CWTS-MC-S.R0025	1.0	Published	-02-2002	http://www.ccsa.org.cn/english/tc/files.php?docpath=/ITU-R/M.1457/M.1457-4/MC
TTA	TTAE.3G-S.R0025 v1.0	1.0	Approved	28-10-2002	http://www.tta.or.kr/standardDB/stnfile/TTAE.3G-S.R0025v1.0.pdf

10.4.23 S.R0026 Version 1.0 High Speed Data Enhancements for cdma 2000 1x – Integrated Data and Voice Stage 1 Requirements (17 October 2000)

This document outlines the key operator requirements for the evolution of the cdma2000 1x (current versions of C.S0001 through C.S0005) standard. This document will refer to this evolution as 1x-evolved high-speed integrated data and voice (1xEV-DV). These requirements are defined to drive improvements to the fundamental packet data capabilities and efficiencies of cdma2000 1x systems to better meet the rapidly evolving needs of subscribers. This document is intended as a guide for 3GPP2 TSGs in the development of specifications for high-speed integrated data and voice systems beyond cdma2000 1x services (voice, fax, circuit switched data), to provide increased

spectral efficiency and the capability to satisfy customer demand for wireless voice and packet data applications.

	Document No.	Version	Status	Issued date	Location
CCSA	CWTS-MC-S.R0026	1.0	Published	-02-2002	http://www.ccsa.org.cn/english/tc/files.php?docpath=/ITU-R/M.1457/M.1457-4/MC
TTA	TTAE.3G-S.R0026	1	Approved	19-12-2001	http://www.tta.or.kr/standardDB/stnfile/TTAE_3G-S_R0026.zip

10.4.24 S.R0027 Version 1 Personal Mobility Stage 1 Requirements (8 December 2000)

The objective is to define and standardize the functionality of personal mobility that can be incorporated into the operations of both 2G/3G TIA/EIA-41 and 2G/3G GSM-derived wireless telecommunications networks. This document defines the requirements of personal mobility features and services.

	Document No.	Version	Status	Issued date	Location
CCSA	CWTS-MC-S.R0027	1	Published	-02-2002	http://www.ccsa.org.cn/english/tc/files.php?docpath=/ITU-R/M.1457/M.1457-4/MC
TTA	TTAE.3G-S.R0027	1	Approved	19-12-2001	http://www.tta.or.kr/standardDB/stnfile/TTAE_3G-S_R0027.zip
TTC	JP-3GB-S.R0027	1	TTC Published	14-05-2001	http://www.ttc.or.jp/imt2000/std/jpsr0027.pdf

10.4.25 S.S0028 Version 1.0 OAM&P for cdma2000 (3GPP Delta Specification) (18 April 2001)

This document contains the OAM&P requirements and interface definitions for cdma2000-based systems. It is an extension of operations and maintenance requirements, per latest 3GPP 32-series specifications capabilities to enable operation in a cdma2000 systems environment as part of the TIA/EIA/IS-2000 family of standards. They are in alignment with OAM&P Stage 1 IS-2000 requirements.

	Document No.	Version	Status	Issued date	Location
CCSA	CWTS-MC-S.S0028	1.0	Published	-02-2002	http://www.ccsa.org.cn/english/tc/files.php?docpath=/ITU-R/M.1457/M.1457-4/MC
TTA	TTAE.3G-S.S0028 V.1.0	1.0	Approved	19-12-2001	http://www.tta.or.kr/standardDB/stnfile/TTAE_3G-S_S0028_v1.0.zip
TTC	JP-3GB-S.S0028v1.0	1.0	TTC Published	29-05-2001	http://www.ttc.or.jp/imt2000/ts/tsss0028-v10.pdf

10.4.25.1 S.S0028 Version 2.0 OAM&P for cdma2000 (3GPP Delta Specification) (23 July 2001)

This document is intended to define the OAM&P stage 2 and stage 3 requirements and interface definitions for cdma2000-based systems.

	Document No.	Version	Status	Issued date	Location
CCSA	CWTS-MC-S.S0028	2.0	Published	-02-2002	http://www.ccsa.org.cn/english/tc/files.php?docpath=/ITU-T/Q.1742/200306/MC
TTA	TTAE.3G-S.S0028 V.2.0	2.0	Approved	19-12-2001	http://www.tta.or.kr/imt2000/TTAE_3G-S_S0028 v2.0.zip
TTC	TS-3GB-S.S0028-0v2.0	2.0	TTC Published	28-11-2001	http://www.ttc.or.jp/imt2000/ts/tsss0028-0v20.pdf

10.4.25.2 S.S0028 Version 3.0 OAM&P for cdma2000 (3GPP Delta Specification) (11 March 2002)

This document is intended to define the OAM&P stage 2 and stage 3 requirements and interface definitions for cdma2000-based systems.

	Document No.	Version	Status	Issued date	Location
CCSA	CWTS-MC-S.S0028	3.0	Published	-06-2002	http://www.ccsa.org.cn/english/tc/files.php?docpath=/ITU-T/Q.1742/200306/MC
TTA	TTAT.3G-S.S0028-0 v3.0	3.0	Approved	21-03-2003	http://www.tta.or.kr/imt2000/TTAT.3G-S.S0028-0 v3.0.zip
TTC	TS-3GB-S.S0028-0v3.0	3.0	TTC Published	28-05-2002	http://www.ttc.or.jp/imt2000/ts/tsss0028-0v30.pdf

10.4.25.3 S.S0028-A Version 1.0 OAM&P for cdma2000 (3GPP R4 Delta Specification) Revision: A (12 December 2002)

This document is intended to define the OAM&P stage 2 and stage 3 requirements and interface definitions for cdma2000-based systems.

	Document No.	Version	Status	Issued date	Location
CCSA	CCSA-TSD-MC-S.S0028-A	1.0	Approved	09-2003	http://www.ccsa.org.cn/english/tc/files.php?docpath=/ITU-T/Q.1742/R3-2003-11
TTA	TTAT.3G-S.S0028-A_v1.0	1.0	Approved	30-10-2003	http://www.tta.or.kr/standardDB/stnfile/TTAT.3G-S.S0028-A_v1.0.zip

10.4.25.4 S.S0028-A Version 2.0 OAM&P for cdma2000 (3GPP R4 Delta Specification) Revision: A (20 February 2003)

This document is intended to define the OAM&P stage 2 and stage 3 requirements and interface definitions for cdma2000-based systems.

	Document No.	Version	Status	Issued date	Location
CCSA	CCSA-TSD-MC-S.S0028-A	2.0	Approved	09-2003	http://www.ccsa.org.cn/english/tc/files.php?docpath=/ITU-T/Q.1742/R3-2003-11
TTA	TTAT.3G-S.S0028-A_v2.0	2.0	Approved	30-10-2003	http://www.tta.or.kr/standardDB/stnfile/TTAT.3G-S.S0028-A_v2.0.zip
TTC	TS-3GB-S.S0028-Av2.0	2.0	TTC Published	30-05-2003	http://www.ttc.or.jp/imt2000/ts/tsss0028-Av20.pdf

10.4.25.5 S.S0028-A Version 3.0 OAM&P for cdma2000 (3GPP R4Delta Specification) Revision: A (20 February 2003)

This document is intended to define the OAM&P stage 2 and stage 3 requirements and interface definitions for cdma2000-based systems.

	Document No.	Version	Status	Issued date	Location
CCSA	CCSA-TSD-MC-S.S0028-A	3.0	Approved	-01-2006	http://www.ccsa.org.cn/english/tc/files.php?docpath=/ITU-T/Q.1742/Q.1742.5
TTA	TTAT.3G-S.S0028-A v3.0	3.0	Approved	19-04-2006	http://www.tta.or.kr/standardDB/stnfile/TTAT.3G-S.S0028-A v3.0.zip
TTC	S.S0028-A v3.0	3.0	TTC Published	25-11-2005	http://www.ttc.or.jp/imt2000/ts/tsss0028-av30.pdf

10.4.25.6 S.S0028-000-B Version 1.0 OAM&P for cdma2000 (Overview) (17 February 2005)

This document is the overview component of a multipart specification intended to define the OAM&P stage 2 and stage 3 requirements and interface definitions for CDMA- and cdma2000^{®2}-based systems. This multipart specification consists of:

- **S.S0028-000-B: "OAM&P for cdma2000 (Overview)".**
- S.S0028-001-B: "OAM&P for cdma2000 (3GPP R5 Delta Specification)".
- S.S0028-002-B: "OAM&P for cdma2000 (3GPP2 Generic NRM IRP)".
- S.S0028-003-B: "OAM&P for cdma2000 (3GPP2 Core NRM IRP)".
- S.S0028-004-B: "OAM&P for cdma2000 (3GPP2 Radio Access NRM IRP)".

	Document No.	Version	Status	Issued date	Location
CCSA	CCSA-TSD-MC-S.S0028-000-B	1.0	Approved	-09-2005	http://www.ccsa.org.cn/english/tc/files.php?docpath=/ITU-T/Q.1742/Q.1742.5
TTA	TTAT.3G-S.S0028-000-B v1.0	1.0	Approved	09-12-2005	http://www.tta.or.kr/standardDB/stnfile/TTAT.3G-S.S0028-000-B v1.0.zip
TTC	TS-3GB-S.S0028-000-Bv1.0	1.0	TTC published	02-06-2005	http://www.ttc.or.jp/imt2000/ts/tsss0028-000-bv10.pdf

10.4.25.7 S.S0028-000-C Version 1.0 OAM&P for cdma2000 (Overview) Revision: C (18 January 2006)

This document is the overview component of a multipart specification intended to define the OAM&P stage 2 and stage 3 requirements and interface definitions for CDMA- and cdma2000[®]-based systems. This multipart specification consists of:

- **S.S0028-000-C: "OAM&P for cdma2000 (Overview)".**
- S.S0028-001-C: "OAM&P for cdma2000 (3GPP R6 Delta Specification)".
- S.S0028-002-C: "OAM&P for cdma2000 (3GPP2 Generic NRM IRP)".
- S.S0028-003-C: "OAM&P for cdma2000 (3GPP2 Core NRM IRP)".
- S.S0028-004-C: "OAM&P for cdma2000 (3GPP2 Radio Access NRM IRP)".

² cdma2000[®] is the trademark for the technical nomenclature for certain specifications and standards of the organizational partners (OPs) of 3GPP2. Geographically (and at the date of publication) cdma2000[®] is a registered trademark of the Telecommunication Industry Association (TIA-USA) in the United States.

	Document No.	Version	Status	Issued date	Location
CCSA	CCSA-S.S0028-000-C v1.0	1.0	Approved	31-01-2007	http://www.ccsa.org.cn/english/tc/files.php?docpath=/ITU-T/Q.1742
TTA	TTAT.3G-S.S0028-000-C v1.0	1.0	Approved	15-02-2007	http://www.tta.or.kr/standardDB/stnfile/TTAT.3G-S.S0028-000-C v1.0.zip
TTC	TS-3GB-S.S0028-000-Cv1.0	1.0	TTC Published	02-06-2006	http://www.ttc.or.jp/imt2000/ts/tsss0028-000-cv10.pdf

10.4.25.8 S.S0028-001-B Version 1.0 OAM&P for cdma2000 (3GPP R5 Delta Specification) (17 February 2005)

This document is the 3GPP R5 delta specification component of a multipart specification intended to define the OAM&P stage 2 and stage 3 requirements and interface definitions for CDMA- and cdma2000[®]-based systems. This multipart specification consists of:

- S.S0028-000-B: "OAM&P for cdma2000 (Overview)".
- **S.S0028-001-B: "OAM&P for cdma2000 (3GPP R5 Delta Specification)".**
- S.S0028-002-B: "OAM&P for cdma2000 (3GPP2 Generic NRM IRP)".
- S.S0028-003-B: "OAM&P for cdma2000 (3GPP2 Core NRM IRP)".
- S.S0028-004-B: "OAM&P for cdma2000 (3GPP2 Radio Access NRM IRP)".

	Document No.	Version	Status	Issued date	Location
CCSA	CCSA-TSD-MC-S.S0028-001-B	1.0	Approved	-09-2005	http://www.ccsa.org.cn/english/tc/files.php?docpath=/ITU-T/Q.1742/Q.1742.5
TTA	TTAT.3G-S.S0028-001-B v1.0	1.0	Approved	09-12-2005	http://www.tta.or.kr/standardDB/stnfile/TTAT.3G-S.S0028-001-B v1.0.zip
TTC	TS-3GB-S.S0028-001-Bv1.0	1.0	TTC published	02-06-2005	http://www.ttc.or.jp/imt2000/ts/tsss0028-001-bv10.pdf

10.4.25.9 S.S0028-001-B Version 2.0 OAM&P for cdma2000 (3GPP R5 Delta Specification) Revision: B (18 July 2005)

This document is the 3GPP R5 delta specification component of a multipart specification intended to define the OAM&P stage 2 and stage 3 requirements and interface definitions for CDMA- and cdma2000[®]-based systems. This multipart specification consists of:

- S.S0028-000-B: "OAM&P for cdma2000 (Overview)".
- **S.S0028-001-B: "OAM&P for cdma2000 (3GPP R5 Delta Specification)".**
- S.S0028-002-B: "OAM&P for cdma2000 (3GPP2 Generic NRM IRP)".
- S.S0028-003-B: "OAM&P for cdma2000 (3GPP2 Core NRM IRP)".
- S.S0028-004-B: "OAM&P for cdma2000 (3GPP2 Radio Access NRM IRP)".

	Document No.	Version	Status	Issued date	Location
CCSA	CCSA-TSD-MC-S.S0028-001-B	2.0	Approved	-01-2006	http://www.ccsa.org.cn/english/tc/files.php?docpath=/ITU-T/Q.1742/Q.1742.5
TTA	TTAT.3G-S.S0028-001-B v2.0	2.0	Approved	19-04-2006	http://www.tta.or.kr/standardDB/stnfile/TTAT.3G-S.S0028-001-B v2.0.zip
TTC	S.S0028-001-B v2.0	2.0	TTC Published	25-11-2005	http://www.ttc.or.jp/imt2000/ts/tsss0028-001-bv20.pdf

**10.4.25.10 S.S0028-001-C Version 1.0 OAM&P for cdma2000 (3GPP R6 Delta Specification)
Revision: C (18 January 2006)**

This document is the 3GPP R6 delta specification component of a multipart specification intended to define the OAM&P stage 2 and stage 3 requirements and interface definitions for CDMA- and cdma2000[®]-based systems. This multipart specification consists of:

- S.S0028-000-C: "OAM&P for cdma2000 (Overview)".
- **S.S0028-001-C: "OAM&P for cdma2000 (3GPP R6 Delta Specification)".**
- S.S0028-002-C: "OAM&P for cdma2000 (3GPP2 Generic NRM IRP)".
- S.S0028-003-C: "OAM&P for cdma2000 (3GPP2 Core NRM IRP)".
- S.S0028-004-C: "OAM&P for cdma2000 (3GPP2 Radio Access NRM IRP)".

	Document No.	Version	Status	Issued date	Location
CCSA	CCSA-S.S0028-001-C v1.0	1.0	Approved	31-01-2007	http://www.ccsa.org.cn/english/tc/files.php?docpath=/ITU-T/Q.1742
TTA	TTAT.3G-S.S0028-001-C v1.0	1.0	Approved	15-02-2007	http://www.tta.or.kr/standardDB/stnfile/TTAT.3G-S.S0028-001-C v1.0.zip
TTC	S.S0028-001-C v1.0	1.0	TTC Published	02-06-2006	http://www.ttc.or.jp/imt2000/ts/tsss0028-001-cv10.pdf

**10.4.25.11 S.S0028-002-B Version 1.0 OAM&P for cdma2000 (3GPP2 Generic NRM IRP)
(17 February 2005)**

This document is the 3GPP2 generic NRM IRP component of a multipart specification intended to define the OAM&P stage 2 and stage 3 requirements and interface definitions for CDMA- and cdma2000[®]-based systems. This multipart specification consists of:

- S.S0028-000-B: "OAM&P for cdma2000 (Overview)".
- S.S0028-001-B: "OAM&P for cdma2000 (3GPP R5 Delta Specification)".
- **S.S0028-002-B: "OAM&P for cdma2000 (3GPP2 Generic NRM IRP)".**
- S.S0028-003-B: "OAM&P for cdma2000 (3GPP2 Core NRM IRP)".
- S.S0028-004-B: "OAM&P for cdma2000 (3GPP2 Radio Access NRM IRP)".

	Document No.	Version	Status	Issued date	Location
CCSA	CCSA-TSD-MC-S.S0028-002-B	1.0	Approved	-09-2005	http://www.ccsa.org.cn/english/tc/files.php?docpath=/ITU-T/Q.1742/Q.1742.5
TTA	TTAT.3G-S.S0028-002-B v1.0	1.0	Approved	09-12-2005	http://www.tta.or.kr/standardDB/stnfile/TTAT.3G-S.S0028-002-B v1.0.zip
TTC	TS-3GB-S.S0028-002-Bv1.0	1.0	TTC published	02-06-2005	http://www.ttc.or.jp/imt2000/ts/tsss0028-002-bv10.pdf

**10.4.25.12 S.S0028-002-C Version 1.0 OAM&P for cdma2000 (3GPP2 Generic NRM IRP)
Revision: C (18 January 2006)**

This document is the 3GPP2 generic NRM IRP component of a multipart specification intended to define the OAM&P stage 2 and stage 3 requirements and interface definitions for CDMA- and cdma2000[®]-based systems. This multipart specification consists of:

- S.S0028-000-C: "OAM&P for cdma2000 (Overview)".
- S.S0028-001-C: "OAM&P for cdma2000 (3GPP R6 Delta Specification)".
- **S.S0028-002-C: "OAM&P for cdma2000 (3GPP2 Generic NRM IRP)".**

- S.S0028-003-C: "OAM&P for cdma2000 (3GPP2 Core NRM IRP)".
- S.S0028-004-C: "OAM&P for cdma2000 (3GPP2 Radio Access NRM IRP)".

	Document No.	Version	Status	Issued date	Location
CCSA	CCSA-S.S0028-002-C v1.0	1.0	Approved	31-01-2007	http://www.ccsa.org.cn/english/tc/files.php?docpath=/ITU-T/Q.1742
TTA	TTAT.3G-S.S0028-002-C v1.0	1.0	Approved	15-02-2007	http://www.tta.or.kr/standardDB/stnfile/TTAT.3G-S.S0028-002-C v1.0.zip
TTC	TS-3GB-S.S0028-002-Cv1.0	1.0	TTC Published	02-06-2006	http://www.ttc.or.jp/imt2000/ts/tsss0028-002-cv10.pdf

10.4.25.13 S.S0028-003-B Version 1.0 OAM&P for cdma2000 (3GPP2 Core NRM IRP) (17 February 2005)

This document is the 3GPP2 Core NRM IRP component of a multipart specification intended to define the OAM&P stage 2 and stage 3 requirements and interface definitions for CDMA- and cdma2000[®]-based systems. This multipart specification consists of:

- S.S0028-000-B: "OAM&P for cdma2000 (Overview)".
- S.S0028-001-B: "OAM&P for cdma2000 (3GPP R5 Delta Specification)".
- S.S0028-002-B: "OAM&P for cdma2000 (3GPP2 Generic NRM IRP)".
- **S.S0028-003-B: "OAM&P for cdma2000 (3GPP2 Core NRM IRP)".**
- S.S0028-004-B: "OAM&P for cdma2000 (3GPP2 Radio Access NRM IRP)".

	Document No.	Version	Status	Issued date	Location
CCSA	CCSA-TSD-MC-S.S0028-003-B	1.0	Approved	-09-2005	http://www.ccsa.org.cn/english/tc/files.php?docpath=/ITU-T/Q.1742/Q.1742.5
TTA	TTAT.3G-S.S0028-003-B v1.0	1.0	Approved	09-12-2005	http://www.tta.or.kr/standardDB/stnfile/TTAT.3G-S.S0028-003-B v1.0.zip
TTC	TS-3GB-S.S0028-003-Bv1.0	1.0	TTC published	02-06-2005	http://www.ttc.or.jp/imt2000/ts/tsss0028-003-bv10.pdf

10.4.25.14 S.S0028-003-B Version 2.0 OAM&P for cdma2000 (3GPP2 Core NRM IRP) Revision: B (18 July 2005)

This document is the 3GPP2 core NRM IRP component of a multipart specification intended to define the OAM&P stage 2 and stage 3 requirements and interface definitions for CDMA- and cdma2000[®]-based systems. This multipart specification consists of:

- S.S0028-000-B: "OAM&P for cdma2000 (Overview)".
- S.S0028-001-B: "OAM&P for cdma2000 (3GPP R5 Delta Specification)".
- S.S0028-002-B: "OAM&P for cdma2000 (3GPP2 Generic NRM IRP)".
- **S.S0028-003-B: "OAM&P for cdma2000 (3GPP2 Core NRM IRP)".**
- S.S0028-004-B: "OAM&P for cdma2000 (3GPP2 Radio Access NRM IRP)".

	Document No.	Version	Status	Issued date	Location
CCSA	CCSA-TSD-MC-S.S0028-003-B	2.0	Approved	-01-2006	http://www.ccsa.org.cn/english/tc/files.php?docpath=/ITU-T/Q.1742/Q.1742.5
TTA	TTAT.3G-S.S0028-003-B v2.0	2.0	Approved	19-04-2006	http://www.tta.or.kr/standardDB/stnfile/TTAT.3G-S.S0028-003-B v2.0.zip
TTC	S.S0028-003-B v2.0	2.0	TTC Published	25-11-2005	http://www.ttc.or.jp/imt2000/ts/tsss0028-003-bv20.pdf

10.4.25.15 S.S0028-003-C Version 1.0 OAM&P for cdma2000 (3GPP2 Core NRM IRP) Revision: C (18 January 2006)

This document is the 3GPP2 Core NRM IRP component of a multipart specification intended to define the OAM&P stage 2 and stage 3 requirements and interface definitions for CDMA- and cdma2000[®]-based systems. This multipart specification consists of:

- S.S0028-000-C: "OAM&P for cdma2000 (Overview)".
- S.S0028-001-C: "OAM&P for cdma2000 (3GPP R6 Delta Specification)".
- S.S0028-002-C: "OAM&P for cdma2000 (3GPP2 Generic NRM IRP)".
- **S.S0028-003-C: "OAM&P for cdma2000 (3GPP2 Core NRM IRP)".**
- S.S0028-004-C: "OAM&P for cdma2000 (3GPP2 Radio Access NRM IRP)".

	Document No.	Version	Status	Issued date	Location
CCSA	CCSA-S.S0028-003-C v1.0	1.0	Approved	31-01-2007	http://www.ccsa.org.cn/english/tc/files.php?docpath=/ITU-T/Q.1742
TTA	TTAT.3G-S.S0028-003-C v1.0	1.0	Approved	15-02-2007	http://www.tta.or.kr/standardDB/stnfile/TTAT.3G-S.S0028-003-C v1.0.zip
TTC	TS-3GB-S.S0028-003-Cv1.0	1.0	TTC Published	02-06-2006	http://www.ttc.or.jp/imt2000/ts/tsss0028-003-cv10.pdf

10.4.25.16 S.S0028-004-B Version 1.0 OAM&P for cdma2000 (3GPP2 Radio Access NRM IRP) (17 February 2005)

This document is the 3GPP2 radio access NRM IRP component of a multipart specification intended to define the OAM&P stage 2 and stage 3 requirements and interface definitions for CDMA- and cdma2000[®]-based systems. This multipart specification consists of:

- S.S0028-000-B: "OAM&P for cdma2000 (Overview)".
- S.S0028-001-B: "OAM&P for cdma2000 (3GPP R5 Delta Specification)".
- S.S0028-002-B: "OAM&P for cdma2000 (3GPP2 Generic NRM IRP)".
- S.S0028-003-B: "OAM&P for cdma2000 (3GPP2 Core NRM IRP)".
- **S.S0028-004-B: "OAM&P for cdma2000 (3GPP2 Radio Access NRM IRP)".**

	Document No.	Version	Status	Issued date	Location
CCSA	CCSA-TSD-MC-S.S0028-004-B	1.0	Approved	-09-2005	http://www.ccsa.org.cn/english/tc/files.php?docpath=/ITU-T/Q.1742/Q.1742.5
TTA	TTAT.3G-S.S0028-004-B v1.0	1.0	Approved	09-12-2005	http://www.tta.or.kr/standardDB/stnfile/TTAT.3G-S.S0028-004-B v1.0.zip
TTC	TS-3GB-S.S0028-004-Bv1.0	1.0	TTC published	02-06-2005	http://www.ttc.or.jp/imt2000/ts/tsss0028-004-bv10.pdf

10.4.25.17 S.S0028-004-B Version 2.0 OAM&P for cdma2000 (3GPP2 Radio Access NRM IRP) (17 February 2005)

This document is the 3GPP2 radio access NRM IRP component of a multipart specification intended to define the OAM&P stage 2 and stage 3 requirements and interface definitions for CDMA- and cdma2000[®]-based systems. This multipart specification consists of:

- S.S0028-000-B: "OAM&P for cdma2000 (Overview)".
- S.S0028-001-B: "OAM&P for cdma2000 (3GPP R5 Delta Specification)".
- S.S0028-002-B: "OAM&P for cdma2000 (3GPP2 Generic NRM IRP)".
- S.S0028-003-B: "OAM&P for cdma2000 (3GPP2 Core NRM IRP)".
- **S.S0028-004-B: "OAM&P for cdma2000 (3GPP2 Radio Access NRM IRP)".**

	Document No.	Version	Status	Issued date	Location
CCSA	CCSA-TSD-MC-S.S0028-004-B	2.0	Approved	-01-2006	http://www.ccsa.org.cn/english/tc/files.php?docpath=/ITU-T/Q.1742/Q.1742.5
TTA	TTAT.3G-S.S0028-004-B v2.0	2.0	Approved	19-04-2006	http://www.tta.or.kr/standardDB/stnfile/TTAT.3G-S.S0028-004-B v2.0.zip
TTC	S.S0028-004-B v2.0	2.0	TTC Published	25-11-2005	http://www.ttc.or.jp/imt2000/ts/tsss0028-004-bv20.pdf

10.4.25.18 S.S0028-004-C Version 1.0 OAM&P for cdma2000 (3GPP2 Radio Access NRM IRP) Revision: C (18 January 2006)

This document is the 3GPP2 radio access NRM IRP component of a multipart specification intended to define the OAM&P stage 2 and stage 3 requirements and interface definitions for CDMA- and cdma2000[®]-based systems. This multipart specification consists of:

- S.S0028-000-C: "OAM&P for cdma2000 (Overview)".
- S.S0028-001-C: "OAM&P for cdma2000 (3GPP R6 Delta Specification)".
- S.S0028-002-C: "OAM&P for cdma2000 (3GPP2 Generic NRM IRP)".
- S.S0028-003-C: "OAM&P for cdma2000 (3GPP2 Core NRM IRP)".
- **S.S0028-004-C: "OAM&P for cdma2000 (3GPP2 Radio Access NRM IRP)".**

	Document No.	Version	Status	Issued date	Location
CCSA	CCSA-S.S0028-004-C v1.0	1.0	Approved	31-01-2007	http://www.ccsa.org.cn/english/tc/files.php?docpath=/ITU-T/Q.1742
TTA	TTAT.3G-S.S0028-004-C v1.0	1.0	Approved	15-02-2007	http://www.tta.or.kr/standardDB/stnfile/TTAT.3G-S.S0028-004-C v1.0.zip
TTC	TS-3GB-S.S0028-004-Cv1.0	1.0	TTC Published	02-06-2006	http://www.ttc.or.jp/imt2000/ts/tsss0028-004-cv10.pdf

10.4.26 S.R0029 Version 1.0.0 Access Control Based on Call Type – Stage 1 Description (22 September 2000)

This document defines requirements for the cdma2000 air interface to support access control based on call type (ACCT). ACCT provides the control of access attempt from mobile stations by service option or a set of service options.

Control for terminating calls to mobile stations is outside the scope of this feature description.

	Document No.	Version	Status	Issued date	Location
CCSA	CWTS-MC-S.R0029	1.0.0	Published	-02-2002	http://www.ccsa.org.cn/english/tc/files.php?docpath=/ITU-R/M.1457/M.1457-4/MC
TTA	TTAE.3G-S.R0029 v1.0.0	1.0.0	Approved	28-10-2002	http://www.tta.or.kr/standardDB/stnfile/TTAE.3G-S.R0029v1.0.0.pdf
TTC	TS-3GB-S.R0029v1.0	1.0	TTC Published	29-05-2001	http://www.ttc.or.jp/imt2000/ts/tssr0029-v10.pdf

10.4.27 S.R0030 Version 1.0 Broadcast/Multicast Services – Stage 1 (22 August 2001)

The objective of this document is to define and to standardize the functionality of broadcast/multicast services that can be incorporated into the operations of cdma2000-based wireless telecommunication networks. This document defines the functional characteristics and requirements of broadcast/multicast services.

	Document No.	Version	Status	Issued date	Location
CCSA	CWTS-MC-S.R0030	1.0.0	Published	-02-2002	http://www.ccsa.org.cn/english/tc/files.php?docpath=/ITU-T/Q.1742/200306/MC
TTA	TTAE.3G-S.R0030-0 v1.0	1.0	Approved	19-12-2001	http://www.tta.or.kr/imt2000/TTAE.3G-S.R0030-0 v1.0.zip
TTC	TS-3GB-S.R0030-0v1.0	1.0	TTC Published	28-11-2001	http://www.ttc.or.jp/imt2000/ts/tssr0030-0v10.pdf

10.4.27.1 S.R0030-A Version 1.0 Broadcast/Multicast Services – Stage 1 Revision A (15 January 2004)

The objective of this document is to define and to standardize the functionality of broadcast/multicast services that can be incorporated into the operations of cdma2000-based wireless telecommunication networks. This document defines the functional characteristics and requirements of broadcast/multicast services.

	Document No.	Version	Status	Issued date	Location
CCSA	CCSA-TSD-MC-S.R0030-A v1.0	1	Approved	15-01-2004	http://www.ccsa.org.cn/english/tc/files.php?docpath=/ITU-T/Q.1742
TTA	TTAT.3G-S.R0030-A v1.0	1.0	Approved	15-11-2004	http://www.tta.or.kr/standardDB/stnfile/TTAT.3G-S.R0030-A v1.0.zip
TTC	TS-3GB-S.R0030-Av1.0	1.0	TTC published	28-05-2004	http://www.ttc.or.jp/imt2000/ts/tssr0030-av10.pdf

10.4.28 S.R0032 Version 1.0 Enhanced Subscriber Authentication (ESA) and Enhanced Subscriber Privacy (ESP) (6 December 2000)

This document defines requirements for the cdma2000 air interface to support enhanced subscriber authentication (ESA) and enhanced subscriber privacy (ESP). ESA provides enhanced security in authentication and ESP provides enhanced privacy of user data. Selection of cryptographic algorithms is outside the scope of this feature description.

	Document No.	Version	Status	Issued date	Location
CCSA	CWTS-MC-S.R0032	1.0	Published	-02-2002	http://www.ccsa.org.cn/english/tc/files.php?docpath=/ITU-R/M.1457/M.1457-4/MC
TTA	TTAE.3G-S.R0032	1	Approved	19-12-2001	http://www.tta.or.kr/standardDB/stnfile/TTAE_3G-S_R0032.zip
TTC	JP-3GB-S.R0032	1	TTC Published	14-05-2001	http://www.ttc.or.jp/imt2000/std/jpsr0032.pdf

10.4.29 S.R0033 Version 1.0 Realm Configured Packet Data Session Dormancy Timer (06 December 2001)

This document specifies the requirements for the operations of the realm configured packet data session dormancy timer (RC-PDSDT) feature from the perspective of the user(s) and/or the system operator. The RC-PDSDT is a timer which is used to measure the duration of dormancy of a packet data session. The purpose of this timer is similar to the packet data inactivity timer specified in the C.S0017 standard.

The objective is to define and to standardize the functionality of this feature/service that can be incorporated into the operations of cdma2000-based wireless telecommunication networks.

	Document No.	Version	Status	Issued date	Location
CCSA	CWTS-MC-S.R0033	1.0	Published	-02-2002	http://www.ccsa.org.cn/english/tc/files.php?docpath=/ITU-T/Q.1742/200306/MC
TTA	TTAT.3G-S.R0033-0 v1.0	1.0	Approved	21-03-2003	http://www.tta.or.kr/imt2000/TTAT.3G-S.R0033-0 v1.0.zip

10.4.30 S.R0034 Version 1.0 User Identification Module ID Manufacturer's Code Assignment Guidelines and Procedures (18 April 2001)

These guidelines are based on the content of the ANSI TIA/EIA-41 family of standards (e.g., AMPS (EIA/TIA-553), CDMA (TIA/EIA-95 and TIA/EIA/IS-2000), and TDMA (IS-54, IS-136)). It is recommended that systems which are based on the ANSI TIA/EIA-41 family of standards and which are deployed outside of the United States follow these guidelines.

	Document No.	Version	Status	Issued date	Location
CCSA	CWTS-MC-S.R0034	1.0	Published	-02-2002	http://www.ccsa.org.cn/english/tc/files.php?docpath=/ITU-R/M.1457/M.1457-4/MC
TTA	TTAE.3G-S.R0034	1.0	Approved	19-12-2001	http://www.tta.or.kr/standardDB/stnfile/TTAE_3G-S_R0034.zip
TTC	TS-3GB-S.R0034v1.0	1.0	TTC Published	29-05-2001	http://www.ttc.or.jp/imt2000/ts/tssr0034-v10.pdf

10.4.30.1 S.R0034 Version 2.0 User Identification Module ID Manufacturer's Code Assignment Guidelines and Procedures (29 August 2002)

These guidelines are based on the content of the ANSI TIA/EIA-41 family of standards (e.g., AMPS (EIA/TIA-553), CDMA (TIA/EIA-95 and TIA/EIA/IS-2000), and TDMA (IS-54, IS-136)). It is recommended that systems which are based on the ANSI TIA/EIA-41 family of standards and which are deployed outside of the United States follow these guidelines. This is to facilitate international roaming and to minimize fraud.

	Document No.	Version	Status	Issued date	Location
CCSA	CCSA-TSD-MC-S.R0034	2.0	Approved	09-2003	http://www.ccsa.org.cn/english/tc/files.php?docpath=/ITU-T/Q.1742/R3-2003-11
TTA	TTAT.3G-S.R0034-0_v2.0	2.0	Approved	30-10-2003	http://www.tta.or.kr/standardDB/stnfile/TTAT.3G-S.R0034-0_v2.0.zip
TTC	TS-3GB-S.R0034-0v2.0	2.0	TTC Published	26-11-2002	http://www.ttc.or.jp/imt2000/ts/tssr0034-0v20.pdf

10.4.31 S.R0037-0 Version 2.0 IP Network Architecture Model for cdma2000 Spread Spectrum Systems (14 May 2002)

The 3GPP2 document is superseded by S.R0037-0 version 3.

10.4.31.1 S.R0037-0 Version 3.0 IP Network Architecture Model for cdma2000 Spread Spectrum Systems (21 August 2003)

This document recommends the basic 3GPP2 wireless IP network architecture model.

	Document No.	Version	Status	Issued date	Location
CCSA	CCSA-TSD-MC-S.R0037-0 v3.0	3.0	Published	21-08-2003	http://www.ccsa.org.cn/english/tc/files.php?docpath=/ITU-T/Q.1742
TTA	TSB-151		Published	-- 12-2003	http://www.tiaonline.org/standards/catalog/search.cfm
TTA	TTAT.3G-S.R0037-0 V3.0	3.0	Approved	15-11-2004	http://www.tta.or.kr/standardDB/stnfile/TTAT.3G-S.R0037-0_v3.0.zip
TTC	TS-3GB-S.R0037-0V3.0	3.0	TTC published	28-11-2003	http://www.ttc.or.jp/imt2000/ts/tssr0037-0v30.pdf

10.4.32 S.R0048 Version 1.0 3G Mobile Equipment Identifier (MEID) (10 May 2001)

The objective of this document is to define and standardize the structure of the 3G mobile equipment identifier.

	Document No.	Version	Status	Issued date	Location
CCSA	CWTS-MC-S.R0048	1.0	Published	-02-2002	http://www.ccsa.org.cn/english/tc/files.php?docpath=/ITU-R/M.1457/M.1457-4/MC
TTA	TTAE.3G-S.R0048-0 V.1.0	1.0	Approved	19-12-2001	http://www.tta.or.kr/standardDB/stnfile/TTAE_3G-S_R0048_v1.0.zip
TTC	TS-3GB-S.R0048v1.0	1.0	TTC Published	29-08-2001	http://www.ttc.or.jp/imt2000/ts/tssr0048-v10.pdf

10.4.32.1 S.R0048-A Version 1.0 3G Mobile Equipment Identifier (MEID) (22 August 2003)

The objective of this document is to define and standardize the structure of the 3G mobile equipment identifier. To facilitate mobile equipment identification and reduce the need to rely on ESNs to track mobiles, the need for a new identifier is required. The mobile equipment identifier (MEID) is proposed as a means to achieve these goals. Additionally, as global roaming and harmonization between 3G technologies become a reality, the need for a universal mobile equipment identifier is needed. The MEID is meant to address these issues.

	Document No.	Version	Status	Issued date	Location
CCSA	CCSA-TSD-MC-S.R0048-A v1.0	1.0	Approved	22-08-2003	http://www.ccsa.org.cn/english/tc/files.php?docpath=/ITU-T/Q.1742
TTA	TTAT.3G-S.R0048-A V1.0	1.0	Approved	15-11-2004	http://www.tta.or.kr/standardDB/stnfile/TTAT.3G-S.R0048-A v1.0.zip
TTC	TS-3GB-S.R0048-AV1.0	1.0	TTC Published	28-11-2003	http://www.ttc.or.jp/imt2000/ts/tssr0048-av10.pdf

10.4.32.2 S.R0048-A Version 2.0 3G Mobile Equipment Identifier (MEID) Stage 1 (22 April 2004)

The objective of this document is to define and standardize the structure of the 3G mobile equipment identifier. To facilitate mobile equipment identification and reduce the need to rely on ESNs to track mobiles, the need for a new identifier is required. The mobile equipment identifier (MEID) is proposed as a means to achieve these goals. Additionally, as global roaming and harmonization between 3G technologies become a reality, the need for a universal mobile equipment identifier is needed. The MEID is meant to address these issues.

	Document No.	Version	Status	Issued date	Location
CCSA	CCSA-TSD-MC-S.R0048-A v2.0	1.0	Approved	22-04-2004	http://www.ccsa.org.cn/english/tc/files.php?docpath=/ITU-T/Q.1742
TIA	TIA-928-1		Approved	-- 04-2004	http://www.tiaonline.org/standards/catalog/search.cfm
TTA	TTAT.3G-S.R0048-A V2.0	2.0	Approved	15-11-2004	http://www.tta.or.kr/standardDB/stnfile/TTAT.3G-S.R0048-A v2.0.zip
TTC	TS-3GB-S.R0048-AV2.0	2.0	TTC Published	03-09-2004	http://www.ttc.or.jp/imt2000/ts/tssr0048-av20.pdf

10.4.32.3 S.R0048-A Version 3.0 3G Mobile Equipment Identifier (MEID) Stage 1 (23 September 2004)

The objective of this document is to define and standardize the structure of the 3G Mobile Equipment Identifier. To facilitate mobile equipment identification and reduce the need to rely on ESNs to track mobiles, the need for a new identifier is required. The Mobile Equipment Identifier (MEID) is proposed as a means to achieve these goals. Additionally, as global roaming and harmonization between 3G technologies becomes a reality, the need for a universal mobile equipment identifier is needed. The MEID is meant to address these issues.

	Document No.	Version	Status	Issued date	Location
CCSA	CCSA-TSD-MC-S.R0048-A	3.0	Approved	09-2005	http://www.ccsa.org.cn/english/tc/files.php?docpath=/ITU-T/Q.1742/Q.1742.5
TTA	TTAT.3G-S.R0048-A V3.0	3.0	Approved	09-12-2005	http://www.tta.or.kr/standardDB/stnfile/TTAT.3G-S.R0048-A v3.0.zip
TTC	TS-3GB-S.R0048-AV3.0	3.0	TTC Published	30-11-2004	http://www.ttc.or.jp/imt2000/ts/tssr0048-av30.pdf

10.4.32.4 S.R0048-A Version 4.0 3G Mobile Equipment Identifier (MEID) Stage 1 (23 June 2005)

The objective of this document is to define and standardize the structure of the 3G mobile equipment identifier.

	Document No.	Version	Status	Issued date	Location
CCSA	CCSA-TSD-MC-S.R0048-A	4.0	Approved	-01-2006	http://www.ccsa.org.cn/english/tc/files.php?docpath=/ITU-T/Q.1742/Q.1742.5
TTA	TTAT.3G-S.R0048-A V4.0	4.0	Approved	19-04-2006	http://www.tta.or.kr/standardDB/stnfile/TTAT.3G-S.R0048-A_v4.0.zip
TTC	TS-3GB-S.R0048-AV4.0	4.0	TTC Published	03-03-2006	http://www.ttc.or.jp/imt2000/ts/tssr0048-av40.pdf

10.4.33 S.R0051 Version 1.0 Enhanced Message Service (EMS) Stage 1 Description (25 July 2001)

This document specifies the system requirements for enhanced message service (EMS).

The objective is to define and to standardize the functionality of this capability that can be incorporated into the operation of cdma2000-based wireless telecommunication networks.

	Document No.	Version	Status	Issued date	Location
CCSA	CWTS-MC-S.R0051	1.0	Published	-02-2002	http://www.ccsa.org.cn/english/tc/files.php?docpath=/ITU-T/Q.1742/200306/MC
TTA	TTAE.3G-S.R0051-0 V.1.0	1.0	Approved	19-12-2001	http://www.tta.or.kr/imt2000/TTAE_3G-S_R0051_v1.0.zip
TTC	TS-3GB-S.R0051-0v1.0	1.0	TTC Published	28-11-2001	http://www.ttc.or.jp/imt2000/ts/tssr0051-0v1.0.pdf

10.4.34 S.R0052-0 Version 1.0 System Release Guide for the Release (ALPHA) of the cdma2000 System Specifications (15 January 2004)

This document is re-numbered as SC.R2003-002 v1.0.

10.4.35 S.S0053 Version 1.0 Common Cryptographic Algorithms (21 January 2002)

This document describes detailed cryptographic procedures for wireless system applications. These procedures are used to perform the security services of mobile station authentication, subscriber message encryption, and encryption key and subscriber voice privacy key generation within wireless equipment.

	Document No.	Version	Status	Issued date	Location
ARIB	STD-T64-S.S0053-0 v1.0	1.0	ARIB Published	29-07-2003	http://www.arib.or.jp/IMT-2000/ARIB-STD/ITU-T/ARIB_ITU-T_Q.1742/ARIB_STD-T64-S.S0053-0_V1.0.PDF
TIA	(none)				
TTA	TTAE.3G-S.S0053 v1.0	1.0	Approved	28-10-2002	http://www.tta.or.kr/imt2000/TTAE.3G-S.S0053-0v1.0.pdf

10.4.36 S.S0054 Version 1.0 Interface Specification for Common Cryptographic Algorithms (21 January 2002)

This document describes the interfaces to cryptographic procedures for wireless system applications. These procedures are used to perform the security services of mobile station authentication, subscriber message encryption, and encryption key and subscriber voice privacy key generation within wireless equipment. The procedures are described in detail in common cryptographic algorithms.

The purpose of this specification is to describe the cryptographic functions without revealing the technical details that are subject to export controls under regional laws. It is intended that developers of 3GPP2 specifications for systems using these cryptographic functions use the information in this document in standards that are not subject to export restrictions.

	Document No.	Version	Status	Issued date	Location
ARIB	STD-T64-S.S0054-0 v1.0	1.0	ARIB Published	29-07-2003	http://www.arib.or.jp/IMT-2000/ARIB-STD/ITU-T/ARIB_ITU-T_Q.1742/ARIB_STD-T64-S.S0054-0_V1.0.PDF
TIA	(none)				
TTA	TTAE.3G-S.S0054 v1.0	1.0	Approved	28-10-2002	http://www.tta.or.kr/imt2000/TTAE.3G-S.S0054-0v1.0.pdf

10.4.37 S.S0055 Version 1.0 Enhanced Cryptographic Algorithms (21 January 2002)

This document describes detailed cryptographic procedures for wireless system applications. These procedures are used to perform the security services of mutual authentication between mobile stations and base stations, subscriber message encryption, and key agreement within wireless equipment.

	Document No.	Version	Status	Issued date	Location
ARIB	STD-T64-S.S0055-0 v1.0	1.0	ARIB Published	29-07-2003	http://www.arib.or.jp/IMT-2000/ARIB-STD/ITU-T/ARIB_ITU-T_Q.1742/ARIB_STD-T64-S.S0055-0_V1.0.PDF
TIA	TIA-946		Published	-- 06-2003	http://www.tiaonline.org/standards/catalog/search.cfm
TTA	TTAE.3G-S.S0055 v1.0	1.0	Approved	28-10-2002	http://www.tta.or.kr/imt2000/TTAE.3G-S.S0055-0v1.0.pdf

10.4.37.1 S.S0055-A Version 1.0 Enhanced Cryptographic Algorithms (-- November 2003)

This document describes detailed cryptographic procedures for wireless system applications. These procedures are used to perform the security services of mutual authentication between mobile stations and base stations, subscriber message encryption, and key agreement within wireless equipment.

	Document No.	Version	Status	Issued date	Location
CCSA	CCSA-TSD-MC-S.S0055-A v1.0	1	Approved	-- 11-2003	http://www.ccsa.org.cn/english/tc/files.php?docpath=/ITU-T/Q.1742
TIA	TIA-946		Published	-- 06-2003	http://www.tiaonline.org/standards/catalog/search.cfm
TTA	TTAT.3G-S.S0055-A V1.0	1.0	Approved	15-11-2004	http://www.tta.or.kr/standardDB/stnfile/TTAT.3G-S.S0055-A v1.0.zip

10.4.37.2 S.S0055-A Version 2.0 Enhanced Cryptographic Algorithms (17 January 2005)

This document describes detailed cryptographic procedures for wireless system applications. These procedures are used to perform the security services of mutual authentication between mobile stations and base stations, subscriber message encryption, and key agreement within wireless equipment.

	Document No.	Version	Status	Issued date	Location
ARIB	STD-T64-S.S0055-A v2.0	2.0	ARIB Published	29-09-2005	http://www.arib.or.jp/IMT-2000/ARIB-STD/ITU-T/T64forQ.1742_5/ARIB_STD-T64-S.S0055-A v2.0.pdf
CCSA	CCSA-TSD-MC-S.S0055-A	2.0	Approved	-09-2005	http://www.ccsa.org.cn/english/tc/files.php?docpath=/ITU-T/Q.1742/Q.1742.5
TTA	TTAT.3G-S.S0055-A V2.0	2.0	Approved	09-12-2005	http://www.tta.or.kr/standardDB/stnfile/TTAT.3G-S.S0055-A v2.0.zip

10.4.37.3 S.S0055-A Version 3.0 Enhanced Cryptographic Algorithms (26 September 2005)

This document describes detailed cryptographic procedures for wireless system applications. These procedures are used to perform the security services of mutual authentication between mobile stations and base stations, subscriber message encryption, and key agreement within wireless equipment.

	Document No.	Version	Status	Issued date	Location
CCSA	CCSA-TSD-MC-S.S0055-A	3.0	Approved	-01-2006	http://www.ccsa.org.cn/english/tc/files.php?docpath=/ITU-T/Q.1742/Q.1742.5
TTA	TTAT.3G-S.S0055-A V3.0	3.0	Approved	19-04-2006	http://www.tta.or.kr/standardDB/stnfile/TTAT.3G-S.S0055-A v3.0.zip

10.4.38 S.R0057 Version 1.0 IP-based Service Architecture System Requirements (09 July 2002)

This document specifies the system requirements for the "IP-based service architecture" from the perspective of the user(s) and/or the network operator for the support of IP multimedia applications.

IP multimedia applications are supported by IP multimedia sessions that use IP connectivity bearers of the all-IP network. This document identifies stage 1 architectural requirements for the all-IP network to support the applications.

The objective is to define and to standardize the "IP-based service architecture" that can be incorporated into the operations of cdma2000-based wireless telecommunication networks.

	Document No.	Version	Status	Issued date	Location
CCSA	CWTS-MC-S.R0057	1.0	Published	-12-2002	http://www.ccsa.org.cn/english/tc/files.php?docpath=/ITU-T/Q.1742/200306/MC
TTA	TTAT.3G-S.R0057-0 v1.0	1.0	Approved	21-03-2003	http://www.tta.or.kr/imt2000/TTAT.3G-S.R0057-0 v1.0.zip
TTC	TS-3GB-S.R0057-0v1.0	1.0	TTC Published	26-11-2002	http://www.ttc.or.jp/imt2000/ts/tssr0057-0v10.pdf

10.4.39 S.R0058 Version 1.0 IP Multimedia Domain System Requirements (17 April 2003)

This document specifies the system requirements for and operations of the IP multimedia domain (IP-MM domain) system. The IP multimedia domain system encompasses the mobile station, the access network and the core network. The various major functions and capabilities of the IP-MM domain system are discussed with a focus on the broad requirements that shall be met in providing those functions and capabilities.

The requirements contained in this document apply to the complete IP multimedia domain system. Actual development of stage 2 and stage 3 work is expected to be done in a phased manner, with

releases of the specifications containing successively more complete implementations of these requirements.

	Document No.	Version	Status	Issued date	Location
CCSA	CCSA-TSD-MC-S.R0058	1.0	Approved	09-2003	http://www.ccsa.org.cn/english/tc/files.php?docpath=/ITU-T/Q.1742/R3-2003-11
TTA	TTAT.3G-S.R0058_v1.0	1.0	Approved	30-10-2003	http://www.tta.or.kr/standardDB/stnfile/TTAT.3G-S.R0058_v1.0.zip

10.4.40 S.R0059 Version 1.0 Legacy MS Domain – Step 1 System Requirements (16 May 2002)

This document specifies the system requirements for and operations of the initial release (step 1) of the legacy MS domain (LMSD) of the all-IP network. Each of the functional entities of the LMSD is described with respect to functionality, interfaces and the roles it plays in the functioning of the network.

The requirements contained in this document apply only to the initial step of the LMSD.

	Document No.	Version	Status	Issued date	Location
CCSA	CWTS-MC-S.R0059	1.0	Published	-12-2002	http://www.ccsa.org.cn/english/tc/files.php?docpath=/ITU-T/Q.1742/200306/MC
TTA	TTAT.3G-S.R0059-0 v1.0	1.0	Approved	21-03-2003	http://www.tta.or.kr/imt2000/TTAT.3G-S.R0059-0 v1.0.zip

10.4.41 S.R0060 Version 1.0 Removable User Identity Module (R-UIM)/Mobile Equipment (ME) Interface Testing Stage 1 Description (14 March 2002)

This document specifies the product conformance objectives to be met by the removable user identity module (R-UIM)/mobile equipment (ME) interface test specification. The overall objective of this activity is the development of an industry standard compliance test specification, which can be employed to ensure that R-UIM-equipped handsets properly interface with various vendor-provided R-UIM cards.

	Document No.	Version	Status	Issued date	Location
ARIB	TR-T13-S.R0060-0 v1.0	1.0	ARIB Published	29-07-2003	http://www.arib.or.jp/IMT-2000/ARIB-STD/ITU-T/ARIB_ITU-T_Q.1742/ARIB_TR-T13-S.R0060-0_V1.0.PDF
CCSA	CWTS-MC-S.R0060	1.0	Published	-12-2002	http://www.ccsa.org.cn/english/tc/files.php?docpath=/ITU-T/Q.1742/200306/MC
TTA	TTAT.3G-S.R0060-0 v1.0	1.0	Approved	21-03-2003	http://www.tta.or.kr/imt2000/TTAT.3G-S.R0060-0 v1.0.zip

10.4.42 S.R0061 Version 1.0 Wireless Immediate Messaging Stage 1 Requirements (25 October 2002)

This document specifies the requirements for and operations of the immediate messaging feature from the perspective of the user(s) and/or the system operator. Immediate messaging (IM) is one of the most popular services on the Internet because of its near real-time, interactive nature. IM, using presence information, allows users to determine when their friends are online and communicate with them in near real-time.

The objective is to define and to standardize the functionality of this feature/service that can be incorporated into the operations of 3GPP2-based wireless telecommunication networks. This

document makes extensive use of the Internet terminology to ensure alignment with immediate messaging service description and behaviour in Internet recommendations.

	Document No.	Version	Status	Issued date	Location
CCSA	CCSA-TSD-MC-S.R0061	1.0	Approved	09-2003	http://www.ccsa.org.cn/english/tc/files.php?docpath=/ITU-T/Q.1742/R3-2003-11
TTA	TTAT.3G-S.R0061-0_v1.0	1.0	Approved	30-10-2003	http://www.tta.or.kr/standardDB/stnfile/TTAT.3G-S.R0061-0_v1.0.zip

10.4.43 S.R0062 Version 1.0 Presence for Wireless Systems Stage 1 Requirements (30 October 2002)

This document defines stage 1 level requirements of the presence service from the perspective of the user and the system operator, so that it may be incorporated into cdma2000-based wireless networks. This document limits itself to presence service and does not delve into other applications that make use of presence, such as instant messaging.

Presence is an attribute related to, but quite different from, mobility information and is a service that can be exploited to create additional services. The presence service enables presence information to be made available to other users or services. This stage 1 makes extensive use of Internet terminology to ensure alignment with the presence service description and behaviour in Internet recommendations.

	Document No.	Version	Status	Issued date	Location
CCSA	CCSA-TSD-MC-S.R0062	1.0	Approved	09-2003	http://www.ccsa.org.cn/english/tc/files.php?docpath=/ITU-T/Q.1742/R3-2003-11
TTA	TTAT.3G-S.R0062-0_v1.0	1.0	Approved	30-10-2003	http://www.tta.or.kr/standardDB/stnfile/TTAT.3G-S.R0062-0_v1.0.zip

10.4.44 S.R0064-0 Version 1.0 Multimedia Messaging Services (MMS) Stage 1 Requirements (30 October 2002)

This document defines the stage 1 description of the non-real-time multimedia messaging service (MMS). MMS will allow users to send and receive messages exploiting the whole array of media types available today, e.g., text, images, audio and video, while also making it possible to support new content types as they become popular. A multimedia message (MM), as observed by the user, is a combination of one or more different media elements in a multimedia presentation that can be transferred without the need to be transferred in real-time. The multimedia messaging service shall be capable of supporting current and future multimedia types, and exploit the advances being made in the multimedia technology, with additional mobile requirements. Stage 1 is the set of requirements seen primarily from the subscriber's and service providers' points of view. It includes information of relevance to network operators, media content suppliers, service providers, and terminal and network manufacturers.

It contains core requirements for the multimedia messaging service, sufficient to provide a complete service.

	Document No.	Version	Status	Issued date	Location
CCSA	CCSA-TSD-MC-S.R0064-0	1.0	Approved	09-2003	http://www.ccsa.org.cn/english/tc/files.php?docpath=/ITU-T/Q.1742/R3-2003-11
TTA	TTAT.3G-S.R0064-0_v1.0	1.0	Approved	30-10-2003	http://www.tta.or.kr/standardDB/stnfile/TTAT.3G-S.R0064-0_v1.0.zip
TTC	TS-3GB-S.R0064-0v1.0	1.0	TTC Published	14-02-2003	http://www.ttc.or.jp/imt2000/ts/tssr0064-0v10.pdf

10.4.45 S.R0065 Version 1.0 Fast Call Set-up System Requirements (15 April 2002)

This document specifies the system requirements for fast call set-up. This feature allows accelerated process in call setup (bearer resource assignment), which is particularly beneficial when a connection is returned from dormancy as a result of a packet arrival to the wireless network. The feature can be considered as falling into the category of standing requirements for network performance improvement.

The objective is to define and to standardize the functionality of this capability that can be incorporated into the operations of cdma2000-based wireless telecommunication networks.

The fast call set-up feature is a set of enhancements/mechanisms that reduce the latency involved in MS-terminated and MS-originated call set-up.

Call-setup involves a set of signalling message exchanges between the mobile station, base station and the network in order to allocate resources and allow user communication to proceed. Each step of this process introduces delay that contributes to the end-to-end call set-up latency. Enhancements that reduce the delay in each step of this process and enhancements that streamline this process result in reduced call set-up latency which is beneficial to cdma2000 services.

	Document No.	Version	Status	Issued date	Location
CCSA	CWTS-MC-S.R0065	1.0	Published	-12-2002	http://www.ccsa.org.cn/english/tc/files.php?docpath=/ITU-T/Q.1742/200306/MC
TTA	TTAT.3G-S.R0065-0 v1.0	1.0	Approved	21-03-2003	http://www.tta.or.kr/imt2000/TTAT.3G-S.R0065-0_v1.0.zip
TTC	TS-3GB-S.R0065-0v1.0	1.0	TTC Published	27-08-2002	http://www.ttc.or.jp/imt2000/ts/tssr0065-0v10.pdf

10.4.46 S.R0066-0 Version 1.0 IP Based Location Services Stage 1 Requirements (17 April 2003)

This version of the Stage 1 supports location through IP in current packet data connections offered in cdma2000. SIP-based services in the all-IP domain (MMD), such as VoIP, are not assumed to be supported. Thus deployment of IP-Based Location Services will be possible prior to a full standardization and deployment of MMD. By the same token, there is no concept of an "emergency call" in the current packet data domain.

	Document No.	Version	Status	Issued date	Location
CCSA	CCSA-TSD-MC-S.R0066-0	1.0	Approved	09-2003	http://www.ccsa.org.cn/english/tc/files.php?docpath=/ITU-T/Q.1742/R3-2003-11
TIA	TIA-1020	1.0	Approved	-- 04-2003	http://www.tiaonline.org/standards/catalog/search.cfm
TTA	TTAT.3G-S.R0066-0_v1.0	1.0	Approved	30-10-2003	http://www.tta.or.kr/standardDB/stnfile/TTAT.3G-S.R0066-0_v1.0.zip

10.4.47 S.R0068 Version 1.0 Link Layer Assisted Robust Header Compression Stage 1 Requirements (11 June 2002)

This document specifies the requirements for and operations of the link layer assisted header compression (LLA HC) from the perspective of the user and the system operator.

The objective is to define and to standardize the functionality of this feature that can be incorporated into the operations of cdma2000-based wireless telecommunication networks.

The scope of this feature is in support of QoS-enabled packet data service. This feature may also be used to support the all-IP multimedia domain, although all-IP is not the only application.

	Document No.	Version	Status	Issued date	Location
CCSA	CWTS-MC-S.R0068	1.0	Published	-12-2002	http://www.ccsa.org.cn/english/tc/files.php?docpath=/ITU-T/Q.1742/200306/MC
TTA	TTAT.3G-S.R0068-0 v1.0	1.0	Approved	21-03-2003	http://www.tta.or.kr/imt2000/TTAT.3G-S.R0068-0 v1.0.zip
TTC	TS-3GB-S.R0068-0v1.0	1.0	TTC Published	26-11-2002	http://www.ttc.or.jp/imt2000/ts/tssr0068-0v10.pdf

10.4.48 S.R0069 Version 1.0 Header Stripping and Generation Stage 1 Requirements (15 March 2002)

This document specifies the requirements for and operations of the header stripping and generation feature from the perspective of the user and the system operator.

The objective is to define and to standardize the functionality of this feature that can be incorporated into the operations of cdma2000-based wireless telecommunication networks.

The scope of this feature is in support of QoS-enabled packet data service. This feature may also be used to support the all-IP multimedia domain, although all-IP is not the only application.

	Document No.	Version	Status	Issued date	Location
CCSA	CWTS-MC-S.R0069	1.0	Published	-12-2002	http://www.ccsa.org.cn/english/tc/files.php?docpath=/ITU-T/Q.1742/200306/MC
TTA	TTAT.3G-S.R0069-0 v1.0	1.0	Approved	21-03-2003	http://www.tta.or.kr/imt2000/TTAT.3G-S.R0069-0 v1.0.zip

10.4.49 S.R0070 Version 1.0 Work Item, Stage 1 and System Requirements Process Guidelines (16 May 2002)

The 3GPP2 document is superseded by SC.R1003-0 v1.0

10.4.50 S.R0071 Version 1.0 Legacy System Packet Data Surveillance Requirements Stage 1 Requirements (18 April 2002)

The 3GPP2 steering committee found that the packet data surveillance feature (also known as packet data intercept, legal surveillance, lawful surveillance, or electronic surveillance) was regional in nature and should be left to the appropriate SDOs to develop, with 3GPP2 consulting as requested.

This document serves as a pointer to the appropriate standards development organization (SDO) documents for packet data surveillance (PDS) for 3GPP2 all-IP systems.

	Document No.	Version	Status	Issued date	Location
CCSA	CWTS-MC-S.R0071	1.0	Published	-12-2002	http://www.ccsa.org.cn/english/tc/files.php?docpath=/ITU-T/Q.1742/200306/MC
TTA	TTAT.3G-S.R0071-0 v1.0	1.0	Approved	21-03-2003	http://www.tta.or.kr/imt2000/TTAT.3G-S.R0071-0 v1.0.zip

10.4.51 S.R0072 Version 1.0 All IP Packet Data Surveillance Requirements Stage 1 Requirements (18 April 2002)

The 3GPP2 steering committee found that the packet data surveillance feature (also known as packet data intercept, legal surveillance, lawful surveillance, or electronic surveillance) was

regional in nature and should be left to the appropriate SDOs to develop, with 3GPP2 consulting as requested.

This document serves as a pointer to the appropriate standards development organization (SDO) documents for packet data surveillance (PDS) for 3GPP2 all-IP systems.

	Document No.	Version	Status	Issued date	Location
CCSA	CWTS-MC-S.R0072	1.0	Published	-12-2002	http://www.ccsa.org.cn/english/tc/files.php?docpath=/ITU-T/Q.1742/200306/MC
TTA	TTAT.3G-S.R0072-0 v1.0	1.0	Approved	21-03-2003	http://www.tta.or.kr/imt2000/TTAT.3G-S.R0072-0 v1.0.zip

10.4.52 S.R0073 Version 1.0 Internet Over-the-Air Handset Configuration Management (IOTA) Stage 1 (11 July 2002)

This document specifies the requirements for and operation of Internet-based over-the-air handset configuration management (IOTA HCM) from the perspective of the users and system operators.

The objective of this document is to define the requirements of this feature for incorporation into the operations of cdma2000-based wireless telecommunication systems.

	Document No.	Version	Status	Issued date	Location
CCSA	CWTS-MC-S.R0073	1.0	Published	-12-2002	http://www.ccsa.org.cn/english/tc/files.php?docpath=/ITU-T/Q.1742/200306/MC
TTA	TTAT.3G-S.R0073-0 v1.0	1.0	Approved	21-03-2003	http://www.tta.or.kr/imt2000/TTAT.3G-S.R0073-0 v1.0.zip
TTC	TS-3GB-S.R0073-0v1.0	1.0	TTC Published	26-11-2002	http://www.ttc.or.jp/imt2000/ts/tssr0073-0v10.pdf

10.4.53 S.R0074 Version 1.0 File Format for Multimedia Services (FFMS) Stage 1 Requirements (17 April 2003)

This document specifies the requirements for the file format for multimedia services (FFMS) feature from the perspective of the user(s) and/or the system operator. The objective is to define and to standardize the file that can be used for interchanging multimedia data in general multimedia services including the multimedia messaging services and the multimedia streaming services. Multimedia data will be stored in a single file. Employing a common file format also enables combined services. For example, a multimedia message is sent to and stored in a multimedia streaming server, and then it is used for streaming to a multimedia streaming client terminal. This document does not specify how this file format is used in specific services.

	Document No.	Version	Status	Issued date	Location
CCSA	CCSA-TSD-MC-S.R0074	1.0	Approved	09-2003	http://www.ccsa.org.cn/english/tc/files.php?docpath=/ITU-T/Q.1742/R3-2003-11
TTA	TTAT.3G-S.R0074_v1.0	1.0	Approved	30-10-2003	http://www.tta.or.kr/standardDB/stnfile/TTAT.3G-S.R0074_v1.0.zip

10.4.54 S.R0075-0 Version 1.0 Accounting and Auditing All-IP System Requirements (17 April 2003)

This document specifies the system requirements for accounting and auditing in the all-IP network architecture model (NAM – S.R0037-0). The AAA is the primary functional entity with respect to the accounting and auditing functionality, interfaces, and the role it plays in the support of facilities and services message accounting in the network.

	Document No.	Version	Status	Issued date	Location
CCSA	CCSA-TSD-MC-S.R0075-0	1.0	Approved	09-2003	http://www.ccsa.org.cn/english/tc/files.php?docpath=/ITU-T/Q.1742/R3-2003-11
TTA	TTAT.3G-S.R0075-0_v1.0	1.0	Approved	30-10-2003	http://www.tta.or.kr/standardDB/stnfile/TTAT.3G-S.R0075-0_v1.0.zip

10.4.55 S.S0078-0 Version 1.0 Common Security Algorithms (12 December 2002)

This document defines detailed cryptographic procedures for common security algorithms in 3GPP2. The procedures include authentication algorithms and privacy algorithms that are intended to satisfy the export restriction requirements of 3GPP2 organizational partners' host countries.

	Document No.	Version	Status	Issued date	Location
ARIB	STD-T64-S.S0078-0 v1.0	1.0	ARIB Published	29-07-2003	http://www.arib.or.jp/IMT-2000/ARIB-STD/ITU-T/ARIB_ITU-T_Q.1742/ARIB_STD-T64-S.S0078-0_V1.0.PDF
CCSA	CCSA-TSD-MC-S.S0078-0	1.0	Approved	09-2003	http://www.ccsa.org.cn/english/tc/files.php?docpath=/ITU-T/Q.1742/R3-2003-11
TTA	TTAT.3G-S.S0078-0_v1.0	1.0	Approved	30-10-2003	http://www.tta.or.kr/standardDB/stnfile/TTAT.3G-S.S0078-0_v1.0.zip

10.4.55.1 S.S0078-A Version 1.0 Common Security Algorithms (13 December 2004)

This document defines detailed cryptographic procedures for common security algorithms in 3GPP2. The procedures include authentication algorithms and privacy algorithms that are intended to satisfy the export restriction requirements of 3GPP2 organizational partners' host countries.

	Document No.	Version	Status	Issued date	Location
CCSA	CCSA-TSD-MC-S.S0078-A	1.0	Approved	-09-2005	http://www.ccsa.org.cn/english/tc/files.php?docpath=/ITU-T/Q.1742/Q.1742.5
TTA	TTAT.3G-S.S0078-A v1.0	1.0	Approved	09-12-2005	http://www.tta.or.kr/standardDB/stnfile/TTAT.3G-S.S0078-A v1.0.zip

10.4.55.2 S.S0078-A Version 2.0 Common Security Algorithms (17 January 2005)

This document defines detailed cryptographic procedures for common security algorithms in 3GPP2. The procedures include authentication algorithms and privacy algorithms that are intended to satisfy the export restriction requirements of 3GPP2 organizational partners' host countries.

	Document No.	Version	Status	Issued date	Location
ARIB	STD-T64-S.S0078-A v2.0	2.0	ARIB Published	29-09-2005	http://www.arib.or.jp/IMT-2000/ARIB-STD/ITU-T/T64forQ.1742_5/ARIB_STD-T64-S.S0078-A v2_0.pdf
CCSA	CCSA-TSD-MC-S.S0078-A	2.0	Approved	-09-2005	http://www.ccsa.org.cn/english/tc/files.php?docpath=/ITU-T/Q.1742/Q.1742.5
TTA	TTAT.3G-S.S0078-A v2.0	2.0	Approved	09-12-2005	http://www.tta.or.kr/standardDB/stnfile/TTAT.3G-S.S0078-A v2.0.zip

10.4.55.3 S.S0078-A Version 3.0 Common Security Algorithms (26 September 2005)

This document defines detailed cryptographic procedures for common security algorithms in 3GPP2. The procedures include authentication algorithms and privacy algorithms that are intended to satisfy the export restriction requirements of 3GPP2 organizational partners' host countries.

	Document No.	Version	Status	Issued date	Location
CCSA	CCSA-TSD-MC-S.S0078-A	3.0	Approved	-01-2006	http://www.ccsa.org.cn/english/tc/files.php?docpath=/ITU-T/Q.1742/Q.1742.5
TTA	TTAT.3G-S.S0078-A v3.0	3.0	Approved	19-04-2006	http://www.tta.or.kr/standardDB/stnfile/TTAT.3G-S.S0078-A v3.0.zip

10.4.56 S.R0079-0 Version 1.0 Support for End-to-End QoS Stage 1 Requirements (13 May 2004)

This document describes the requirements necessary to support end-to-end (E2E) QoS in the cdma2000 wireless IP network. The requirements are based on leveraging and extending, where applicable, the standard IETF protocols for QoS. The proposed functionality described by the requirements include the use of int-serv, diff-serv, int-serv to diff-serv interworking, network policy and subscriber profile, network provisioning and link layer to upper layer QoS adaptation. The document also specifies the requirements for the cdma2000 radio link QoS.

	Document No.	Version	Status	Issued date	Location
CCSA	CCSA-TSD-MC-S.R0079-0 v1.0	1	Approved	13-05-2004	http://www.ccsa.org.cn/english/tc/files.php?docpath=/ITU-T/Q.1742
TTA	TTAT.3G-S.R0079-0 V1.0	1.0	Approved	15-11-2004	http://www.tta.or.kr/standardDB/stnfile/TTAT.3G-S.R0079-0 v1.0.zip
TTC	TS-3GB-S.R0079-0V1.0	1.0	TTC Published	03-09-2004	http://www.ttc.or.jp/imt2000/ts/tssr0079-0v10.pdf

10.4.56.1 S.R0079-A Version 1.0 Support for End-to-End QoS Stage 1 Requirements (29 June 2006)

This document describes the requirements necessary to support end-to-end (E2E) QoS in the cdma2000 wireless IP network. The requirements are based on leveraging and extending, where applicable, the standard IETF protocols for QoS. The proposed functionality described by the requirements include the use of int-serv, diff-serv, int-serv to diff-serv interworking, network policy and subscriber profile, network provisioning and link layer to upper layer QoS adaptation. The document also specifies the requirements for the cdma2000 radio link QoS.

	Document No.	Version	Status	Issued date	Location
CCSA	CCSA-S.R0079-A v1.0	1.0	Approved	31-01-2007	http://www.ccsa.org.cn/english/tc/files.php?docpath=/ITU-T/Q.1742
TTA	TTAT.3G-S.R0079-A V1.0	1.0	Approved	15-02-2007	http://www.tta.or.kr/standardDB/stnfile/TTAT.3G-S.R0079-A v1.0.zip
TTC	TS-3GB-S.R0079-AV1.0	1.0	TTC Published	25-08-2006	http://www.ttc.or.jp/imt2000/ts/tssr0079-av10.pdf

10.4.57 S.R0080-0 Version 1.0 cdma2000 Wideband Speech Codec Stage 1 Requirements (20 February 2003)

Wideband speech and audio coding has been gaining popularity in recent years. The emergence of the third generation cellular systems as well as increasing public demand for applications such as wireless multimedia, voice-over-IP, videophone, ISDN teleconferencing systems, multipoint interactive audiovisual communication and audio streaming require improved voice quality and intelligibility. Multimedia services are among the main deliverables of 3G wireless communications. This implies the use of high quality audio and speech in multimedia content. Even in 3G voice applications, the introduction of wideband speech would be an important step for CDMA service providers to deliver speech quality beyond the traditional limits of wireline communication systems.

This document describes the cdma2000 wideband speech codec stage 1 requirements.

	Document No.	Version	Status	Issued date	Location
ARIB	TR-T13-S.R0080-0v1.0	1.0	ARIB Published	29-07-2003	http://www.arib.or.jp/IMT-2000/ARIB-STD/ITU-T/ARIB_ITU-T_Q.1742/ARIB_TR-T13-S.R0080-0_v1.pdf
CCSA	CCSA-TSD-MC-S.R0080-0	1.0	Approved	09-2003	http://www.ccsa.org.cn/english/tc/files.php?docpath=/ITU-T/Q.1742/R3-2003-11
TTA	TTAT.3G-S.R0080-0_v1.0	1.0	Approved	30-10-2003	http://www.tta.or.kr/standardDB/stnfile/TTAT.3G-S.R0080-0_v1.0.zip

10.4.58 S.R0082 Version 1.0 Enhanced Packet Data Air Interface Security (22 August 2003)

This document defines requirements for the cdma2000 air interface to support data subscriber authentication (DSA) and data privacy (DP) for packet data services. DSA provides enhanced security in authentication and DP provides enhanced privacy of user data. DSA provides mutual authentication between the access terminal and the serving access network. DP provides encryption to prevent signalling and user traffic from unauthorized disclosure, and to prevent hijacking of user data channels.

	Document No.	Version	Status	Issued date	Location
CCSA	CCSA-TSD-MC-S.R0082 v1.0	1	Approved	22-08-2003	http://www.ccsa.org.cn/english/tc/files.php?docpath=/ITU-T/Q.1742
TTA	TTAT.3G-S.R0082 V1.0	1.0	Approved	15-11-2004	http://www.tta.or.kr/standardDB/stnfile/TTAT.3G-S.R0082_v1.0.zip
TTC	TS-3GB-S.R0082-0V1.0	1.0	TTC Published	28-11-2003	http://www.ttc.or.jp/imt2000/ts/tssr0082-0v10.pdf

10.4.59 S.S0083-A Version 1.0 Broadcast-Multicast Service Security Framework (26 August 2004)

This document defines the security framework for the broadcast-multicast services (BCMCS). The security framework provides a logical description of the security information, functions and protocols for BCMCS.

	Document No.	Version	Status	Issued date	Location
CCSA	CCSA-TSD-MC-S.S0083-A	1.0	Approved	-09-2005	http://www.ccsa.org.cn/english/tc/files.php?docpath=/ITU-T/Q.1742/Q.1742.5
TIA	TIA-1053		Published	-- 09-2004	http://www.tiaonline.org/standards/catalog/search.cfm
TTA	TTAT.3G-S.S0083-A V1.0	1.0	Approved	09-12-2005	http://www.tta.or.kr/standardDB/stnfile/TTAT.3G-S.S0083-A v1.0.zip
TTC	TS-3GB-S.S0083-AV1.0	1.0	TTC Published	30-11-2004	http://www.ttc.or.jp/imt2000/ts/tsss0083-av10.pdf

10.4.60 S.R0084-0 Version 2.0 Prepaid Packet Data Service in cdma2000 Wireless IP Network, Stage 1 Requirements (18 September 2003)

Prepaid service allows the subscriber to pay for packet data services prior to usage. A prepaid subscriber establishes an account with the service provider to access packet data services in home and roaming networks.

	Document No.	Version	Status	Issued date	Location
CCSA	CCSA-TSD-MC-S.R0084-0v2.0	1	Approved	18-09-2003	http://www.ccsa.org.cn/english/tc/files.php?docpath=/ITU-T/Q.1742
TTA	TTAT.3G-S.R0084-0 V2.0	2.0	Approved	15-11-2004	http://www.tta.or.kr/standardDB/stnfile/TTAT.3G-S.R0084-0 v2.0.zip
TTC	TS-3GB-S.R0084-0V2.0	2.0	TTC Published	28-11-2003	http://www.ttc.or.jp/imt2000/ts/tssr0084-0v20.pdf

10.4.61 S.R0086-A Version 1.0 IMS Security Framework (10 June 2004)

This document addresses the access and network security for IP-based services. The scope of this technical specification is to specify the security features and mechanisms for secure access to the IM subsystem (IMS) for the 3G mobile telecommunication system.

	Document No.	Version	Status	Issued date	Location
CCSA	CCSA-TSD-MC-S.R0086-Av1.0	1	Approved	10-06-2004	http://www.ccsa.org.cn/english/tc/files.php?docpath=/ITU-T/Q.1742
TTA	TTAT.3G-S.R0086-A V1.0	1.0	Approved	15-11-2004	http://www.tta.or.kr/standardDB/stnfile/TTAT.3G-S.R0086-A v1.0.zip
TTC	TS-3GB-S.R0086-AV1.0	1.0	TTC Published	03-09-2004	http://www.ttc.or.jp/imt2000/ts/tssr0086-Av10.pdf

10.4.61.1 S.S0086-B Version 1.0 IMS Security Framework (08 December 2005)

This document addresses the access and network security for IP-based services. The scope of this technical specification is to specify the security features and mechanisms for secure access to the IM subsystem (IMS) for the 3G mobile telecommunication system.

	Document No.	Version	Status	Issued date	Location
CCSA	CCSA-TSD-MC-S.R0086-B	1	Approved	-01-2006	http://www.ccsa.org.cn/english/tc/files.php?docpath=/ITU-T/Q.1742/Q.1742.5
TIA	TIA-1091		Published	-- 12-2005	http://www.tiaonline.org/standards/catalog/search.cfm
TTA	TTAT.3G-S.S0086-B V1.0	1.0	Approved	19-04-2006	http://www.tta.or.kr/standardDB/stnfile/TTAT.3G-S.S0086-B v1.0.zip
TTC	S.S0086-B V1.0	1.0	TTC Published	03-03-2006	http://www.ttc.or.jp/imt2000/ts/tsss0086-bv10.pdf

10.4.62 S.R0087-0 Version 1.0 3GPP2 – WLAN Interworking Stage 1 Requirements (22 July 2004)

This document describes requirements of interworking between 3GPP2 systems and wireless local area networks (WLANs). The intent of 3GPP2-WLAN interworking is to extend 3GPP2 packet data services and/or capabilities to the WLAN environment.

	Document No.	Version	Status	Issued date	Location
CCSA	CCSA-TSD-MC-S.R0087-0	1.0	Approved	-09-2005	http://www.ccsa.org.cn/english/tc/files.php?docpath=/ITU-T/Q.1742/Q.1742.5
TTA	TTAT.3G-S.R0087-0 v1.0	1.0	Approved	09-12-2005	http://www.tta.or.kr/standardDB/stnfile/TTAT.3G-S.R0087-0 v1.0.zip
TTC	TS-3GB-S.R0087-0V1.0	1.0	TTC Published	30-11-2004	http://www.ttc.or.jp/imt2000/ts/tssr0087-0v10.pdf

10.4.62.1 S.R0087-A Version 1.0 cdma2000 – WLAN Interworking Stage 1 Requirements (23 February 2006)

This document describes requirements of interworking between cdma2000[®] systems and wireless local area networks (WLANs). The intent of cdma2000-WLAN is to extend cdma2000 packet data and multimedia services and/or capabilities to the WLAN environment, and to support the handoff of voice calls between WLAN and cdma2000 1x circuit-switched (CS) environments.

	Document No.	Version	Status	Issued date	Location
CCSA	CCSA-S.R0087-A v1.0	1.0	Approved	31-01-2007	http://www.ccsa.org.cn/english/tc/files.php?docpath=/ITU-T/Q.1742
TTA	TTAT.3G-S.R0087-A v1.0	1.0	Approved	15-02-2007	http://www.tta.or.kr/standardDB/stnfile/TTAT.3G-S.R0087-A v1.0.zip
TTC	TS-3GB-S.R0087-AV1.0	1.0	TTC Published	02-06-2006	http://www.ttc.or.jp/imt2000/ts/tssr0087-av10.pdf

10.4.63 S.R0090-0 Version 1.0 Network Initiated Data Session (NIDS) Stage 1 Requirements (10 June 2004)

This document defines the requirements for providing the network initiated data session (NIDS) capability.

	Document No.	Version	Status	Issued date	Location
CCSA	CCSA-TSD-MC-S.R0090-0 v1.0	1	Approved	10-06-2004	http://www.ccsa.org.cn/english/tc/files.php?docpath=/ITU-T/Q.1742
TTA	TTAT.3G-S.R0090-0 V1.0	1.0	Approved	15-11-2004	http://www.tta.or.kr/standardDB/stnfile/TTAT.3G-S.R0090-0 v1.0.zip
TTC	TS-3GB-S.R0090-0V1.0	1.0	TTC Published	03-09-2004	http://www.ttc.or.jp/imt2000/ts/tssr0090-0v10.pdf

10.4.64 S.R0092-0 Version 1.0 Legacy MS Domain Step 2 System Requirements (18 March 2004)

This document specifies the system requirements for and operations of the second release (step 2) of the legacy MS domain (LMSD) of the all-IP network. Each of the functional entities of the LMSD is described with respect to functionality, interfaces, and the roles it plays in the functioning of the network.

	Document No.	Version	Status	Issued date	Location
CCSA	CCSA-TSD-MC-S.R0092-0 v1.0	1	Approved	18-03-2004	http://www.ccsa.org.cn/english/tc/files.php?docpath=/ITU-T/Q.1742
TTA	TTAT.3G-S.R0092-0 V1.0	1.0	Approved	15-11-2004	http://www.tta.or.kr/standardDB/stnfile/TTAT.3G-S.R0092-0 v1.0.zip
TTC	TS-3GB-S.R0092-0V1.0	1.0	TTC Published	28-05-2004	http://www.ttc.or.jp/imt2000/ts/tssr0092-0v10.pdf

10.4.65 S.S0093-0 Version 1.0 cdma2000 Network Performance Measurement Types (11 December 2003)

This document defines the performance measurement types applicable to CDMA and cdma2000[®] systems.

	Document No.	Version	Status	Issued date	Location
CCSA	CCSA-TSD-MC-S.S0093-0 v1.0	1	Approved	11-12-2003	http://www.ccsa.org.cn/english/tc/files.php?docpath=/ITU-T/Q.1742
TTA	TTAT.3G-S.S0093-0 V1.0	1.0	Approved	15-11-2004	http://www.tta.or.kr/standardDB/stnfile/TTAT.3G-S.S0093-0 v1.0.zip
TTC	TS-3GB-S.S0093-0V1.0	1.0	TTC Published	28-05-2004	http://www.ttc.or.jp/imt2000/ts/tsss0093-0v10.pdf

10.4.65.1 S.S0093-0 Version 2.0 cdma2000 Network Performance Measurement Types Revision: 0 (18 January 2006)

This document defines the performance measurement types applicable to CDMA and cdma2000[®] systems.

	Document No.	Version	Status	Issued date	Location
CCSA	CCSA-TSD-MC-S.S0093-0 v2.0	2.0	Approved	31-01-2007	http://www.ccsa.org.cn/english/tc/files.php?docpath=/ITU-T/Q.1742
TTA	TTAT.3G-S.S0093-0 V2.0	2.0	Approved	15-02-2007	http://www.tta.or.kr/standardDB/stnfile/TTAT.3G-S.S0093-0 v2.0.zip
TTC	TS-3GB-S.S0093-0V2.0	2.0	TTC Published	02-06-2006	http://www.ttc.or.jp/imt2000/ts/tsss0093-0v20.pdf

10.4.66 S.R0094-0 Version 1.0 R_m Interface Enhancements for cdma2000 System Requirements (17 February 2005)

This document specifies the system requirements for an enhanced R_m interface. The objective is to define and to standardize the functionality of this interface for incorporation into the operations of cdma2000[®] based wireless telecommunication networks.

The R_m interface is between a mobile termination 2 (MT2) and a terminal equipment 2 (TE2). An MT2 is a cdma2000 network interface device, such as a hand-held phone. A TE2 is a general-purpose computer such as a laptop. The R_m Interface is currently specified in C.S0017 to support only a best-effort, point-to-point packet data link assuming the presence of an RS-232 physical layer. Enhancements are needed to support applications hosted on the TE2 that require quality of service (QoS) from the cdma2000 network, and to support a network-layer interface that can be re-used across many different physical layer technologies.

	Document No.	Version	Status	Issued date	Location
CCSA	CCSA-TSD-MC-S.R0094-0	1.0	Approved	-09-2005	http://www.ccsa.org.cn/english/tc/files.php?docpath=/ITU-T/Q.1742/Q.1742.5
TTA	TTAT.3G-S.R0094-0 V1.0	1.0	Approved	09-12-2005	http://www.tta.or.kr/standardDB/stnfile/TTAT.3G-S.R0094-0 v1.0.zip
TTC	TS-3GB-S.R0094-0V1.0	1.0	TTC Published	02-06-2005	http://www.ttc.or.jp/imt2000/ts/tssr0094-0v10.pdf

10.4.67 S.R0095-0 Version 1.0 Support for IP Multimedia Services identity Module (ISIM) on Universal Integrated Circuit Card (UICC) in 3GPP2 Systems Stage 1 Requirements (10 June 2004)

This document defines the enhancements required for the support of IMS-capable mobile stations equipped with universal integrated circuit card (UICC). This document specifies the requirements and operations for the support of ISIM on UICC.

	Document No.	Version	Status	Issued date	Location
CCSA	CCSA-TSD-MC-S.R0095-0-v1.0	1	Approved	10-06-2004	http://www.ccsa.org.cn/english/tc/files.php?docpath=/ITU-T/Q.1742
TTA	TTAT.3G-S.R0095-0 V1.0	1.0	Approved	15-11-2004	http://www.tta.or.kr/standardDB/stnfile/TTAT.3G-S.R0095-0 v1.0.zip
TTC	TS-3GB-S.R0095-0V1.0	1.0	TTC Published	03-09-2004	http://www.ttc.or.jp/imt2000/ts/tssr0095-0v10.pdf

10.4.68 S.R0096-0 Version 1.0 Transcoder Free Operation Stage 1 Requirements (18 March 2004)

This document states that transcoder free operation (TrFO) is the transport of compressed speech, from legacy mobiles, in a packet transport network through the elimination of unnecessary coding and decoding of the signal by intermediate elements in the bearer path. Transcoders may be associated either with the RAN or media gateway (MGW). By transporting only the compressed speech, TrFO achieves bandwidth efficiencies in the bearer stream and reduces round-trip delays introduced by unnecessary transcoding. Also, TrFO may increase voice quality. TrFO is not applicable to VoIP. TrFO is a capability of the legacy MS domain.

	Document No.	Version	Status	Issued date	Location
CCSA	CCSA-TSD-MC-S.R0096-0 v1.0	1	Approved	18-03-2004	http://www.ccsa.org.cn/english/tc/files.php?docpath=/ITU-T/Q.1742
TTA	TTAT.3G-S.R0096-0 V1.0	1.0	Approved	15-11-2004	http://www.tta.or.kr/standardDB/stnfile/TTAT.3G-S.R0096-0 v1.0.zip
TTC	TS-3GB-S.R0096-0V1.0	1.0	TTC Published	28-05-2004	http://www.ttc.or.jp/imt2000/ts/tssr0096-0v10.pdf

10.4.69 S.R0103-0 Version 1.0 Network Firewall Configuration and Control (NFCC) – Stage 1 Requirements (09 December 2004)

This document specifies the system requirements and operation of the network firewall configuration and control (NFCC) feature, from both the perspective of the subscriber and the system operator. The objective is to define and to standardize the functionality of this feature to be incorporated into the operations of cdma2000[®]-based wireless telecommunication networks.

	Document No.	Version	Status	Issued date	Location
CCSA	CCSA-TSD-MC-S.R0103-0	1.0	Approved	-09-2005	http://www.ccsa.org.cn/english/tc/files.php?docpath=/ITU-T/Q.1742/Q.1742.5
TTA	TTAT.3G-S.R0103-0 V1.0	1.0	Approved	09-12-2005	http://www.tta.or.kr/standardDB/stnfile/TTAT.3G-S.R0103-0 v1.0.zip
TTC	TS-3GB-S.R0103-0V1.0	1.0	TTC Published	03-03-2005	http://www.ttc.or.jp/imt2000/ts/tssr0103-0v10.pdf

10.4.70 S.R0104-0 Version 1.0 HRPD Network Access Authentication for a Hybrid Access Terminal (HAT) with an R-UIM Used to Access Spread Spectrum Systems – Systems Requirements (21 October 2004)

A hybrid access terminal (referred to herein as a hybrid access terminal or HAT) is a device which can access both cdma2000[®] 1x and HRPD networks for packet data services.

To access the cdma2000 1x network, a HAT that has an R-UIM uses R-UIM-supported CAVE-based authentication. To access the HRPD network, an optional network access authentication step may be required by the HRPD network. This optional step uses CHAP to exchange a challenge and response between the HAT and HRPD network. Currently, CHAP specifies that MD5 is used to compute the response. It is important to note that MD5 is not currently supported by all R-UIMs used to access a cdma2000 1x network.

For an operator that deploys both cdma2000 1x and HRPD networks, there can be benefits to using common authentication credentials and authentication methods for accessing both networks.

These requirements allow a properly configured HAT with an R-UIM to use CAVE-based authentication for access to both networks. These requirements specify the HAT authentication requirements and also the support required by the HRPD AN-AAA to authenticate such a HAT.

	Document No.	Version	Status	Issued date	Location
CCSA	CCSA-TSD-MC-S.R0104-0	1.0	Approved	-09-2005	http://www.ccsa.org.cn/english/tc/files.php?docpath=/ITU-T/Q.1742/Q.1742.5
TTA	TTAT.3G-S.R0104-0 V1.0	1.0	Approved	09-12-2005	http://www.tta.or.kr/standardDB/stnfile/TTAT.3G-S.R0104-0 v1.0.zip
TTC	TS-3GB-S.R0104-0V1.0	1.0	TTC Published	03-03-2005	http://www.ttc.or.jp/imt2000/ts/tssr0104-0v10.pdf

10.4.71 S.R0105-0 Version 1.0 Hot-lining Service (Packet Data) Stage 1 Requirements (08 December 2004)

This document specifies the system requirements for hot-lining for packet data service. The objective is to define and to standardize the functionality of this capability that can be incorporated into the operations of cdma2000[®]-based wireless IP networks.

	Document No.	Version	Status	Issued date	Location
CCSA	CCSA-TSD-MC-S.R0105-0	1.0	Approved	-09-2005	http://www.ccsa.org.cn/english/tc/files.php?docpath=/ITU-T/Q.1742/Q.1742.5
TTA	TTAT.3G-S.R0105-0 V1.0	1.0	Approved	09-12-2005	http://www.tta.or.kr/standardDB/stnfile/TTAT.3G-S.R0105-0 v1.0.zip
TTC	TS-3GB-S.R0105-0V1.0	1.0	TTC Published	03-03-2005	http://www.ttc.or.jp/imt2000/ts/tssr0105-0v10.pdf

10.4.72 S.R0106-0 Version 1.0 Packet-Switched Video Telephony Stage 1 (21 July 2005)

This document defines the functional characteristics and the requirements of the packet-switched video telephony (VT) services, sometimes also referred to as multimedia conversational services (MCS). Video telephony is defined as one-to-one video/speech communication capability.

	Document No.	Version	Status	Issued date	Location
CCSA	CCSA-TSD-MC-S.R0106-0	1.0	Approved	-01-2006	http://www.ccsa.org.cn/english/tc/files.php?docpath=/ITU-T/Q.1742/Q.1742.5
TTA	TTAT.3G-S.R0106-0 V1.0	1.0	Approved	19-04-2006	http://www.tta.or.kr/standardDB/stnfile/TTAT.3G-S.R0106-0 v1.0.zip
TTC	S.R0106-0 V1.0	1.0	TTC Published	25-11-2005	http://www.ttc.or.jp/imt2000/ts/tssr0106-0v10.pdf

10.4.73 S.R0108-0 Version 1.0 HRPD-cdma2000 1x Interoperability for Voice and Data System Requirements (23 February 2006)

This document defines the system requirements for HRPD-cdma2000 1x interoperability for voice and data. The cellular network includes multimedia domain (MMD), legacy mobile station domain (LMSD) support, and HRPD/cdma2000 1x radio access networks (RANs) for the delivery of voice, video and data services.

	Document No.	Version	Status	Issued date	Location
CCSA	CCSA-S.R0108-0 v1.0	1.0	Approved	31-01-2007	http://www.ccsa.org.cn/english/tc/files.php?docpath=/ITU-T/Q.1742
TTA	TTAT.3G-S.R0108-0 V1.0	1.0	Approved	15-02-2007	http://www.tta.or.kr/standardDB/stnfile/TTAT.3G-S.R0108-0 v1.0.zip
TTC	TS-3GB-S.R0108-0V1.0	1.0	TTC Published	02-06-2006	http://www.ttc.or.jp/imt2000/ts/tssr0108-0v10.pdf

10.4.74 S.S0109-0 Version 1.0 Generic Bootstrapping Architecture (GBA) Framework (30 March 2006)

This document describes the security features and a mechanism to bootstrap keys for application security. The scope of this specification includes a generic bootstrapping function, an architecture overview and the detailed procedure how to bootstrap the credential. The specification also describes a mechanism, called GBA_U, to bootstrap keys inside the (R-)UIM as well as keys in the ME. GBA_U requires GBA support in the (R-)UIM, but provides enhanced security by storing certain derived keys on the (R-)UIM.

	Document No.	Version	Status	Issued date	Location
CCSA	CCSA-S.S0109-0 v1.0	1.0	Approved	31-01-2007	http://www.ccsa.org.cn/english/tc/files.php?docpath=/ITU-T/Q.1742
TTA	TTAT.3G-S.S0109-0 V1.0	1.0	Approved	15-02-2007	http://www.tta.or.kr/standardDB/stnfile/TTAT.3G-S.S0109-0 v1.0.zip
TTC	TS-3GB-S.S0109-0V1.0	1.0	TTC Published	02-06-2006	http://www.ttc.or.jp/imt2000/ts/tsss0109-0v10.pdf

10.4.75 S.S0110-0 Version 1.0 IP-Based Location Services Security Framework (23 February 2006)

This document defines the security framework for the IP-based location services. The security framework provides a logical description of the security information, functions and protocols for IP-based location services. The architectural design of the network that supports these functions is outside the scope of this document.

	Document No.	Version	Status	Issued date	Location
CCSA	CCSA-S.S0110-0 v1.0	1.0	Approved	31-01-2007	http://www.ccsa.org.cn/english/tc/files.php?docpath=/ITU-T/Q.1742
TTA	TTAT.3G-S.S0110-0 V1.0	1.0	Approved	15-02-2007	http://www.tta.or.kr/standardDB/stnfile/TTAT.3G-S.S0110-0 v1.0.zip
TTC	TS-3GB-S.S0110-0V1.0	1.0	TTC Published	02-06-2006	http://www.ttc.or.jp/imt2000/ts/tsss0110-0v10.pdf

10.4.76 S.R0111-0 Version 1.0 Expanded R-UIM Identifier (26 October 2005)

An expanded R-UIM identifier (EUIM-ID) solution is needed in time to address issues associated with the impending exhaustion of the existing 32-bit UIM_ID/ESN numbering space in CDMA networks. The purpose of introducing a new identifier is to define a larger numbering space, and also set the stage for moving away from the functions such as authentication and reverse long code mask generation.

	Document No.	Version	Status	Issued date	Location
CCSA	CCSA-TSD-MC-S.R0111-0	1.0	Approved	-01-2006	http://www.ccsa.org.cn/english/tc/files.php?docpath=/ITU-T/Q.1742/Q.1742.5
TTA	TTAT.3G-S.R0111-0 V1.0	1.0	Approved	19-04-2006	http://www.tta.or.kr/standardDB/stnfile/TTAT.3G-S.R0111-0 v1.0.zip
TTC	S.R0111-0 V1.0	1.0	TTC Published	03-03-2006	http://www.ttc.or.jp/imt2000/ts/tssr0111-0v10.pdf

10.4.77 S.R0112-0 Version 1.0 Generic Bootstrapping Architecture System Requirements (08 December 2005)

This specification contains the high level requirements for the generic bootstrapping architecture work. The aim of this work is to specify a general method of providing an application and a mobile with some shared keying material. The requirements on how the application and mobile use this shared keying material is outside the scope of this specification.

	Document No.	Version	Status	Issued date	Location
CCSA	CCSA-TSD-MC-S.R0112-0	1.0	Approved	-01-2006	http://www.ccsa.org.cn/english/tc/files.php?docpath=/ITU-T/Q.1742/Q.1742.5
TTA	TTAT.3G-S.R0112-0 V1.0	1.0	Approved	19-04-2006	http://www.tta.or.kr/standardDB/stnfile/TTAT.3G-S.R0112-0 v1.0.zip
TTC	S.R0112-0 V1.0	1.0	TTC Published	25-11-2005	http://www.ttc.or.jp/imt2000/ts/tssr0112-0v10.pdf

10.4.78 S.R0113-0 Version 1.0 cdma2000 Enhanced Packet Data Air Interface System – System Requirements Document (25 May 2006)

This document specifies the system requirements for the development of the cdma2000[®] enhanced packet data air interface (E-PDAI) system. E-PDAI is a part of cdma2000 evolution effort. This document is intended to be used to guide the formal technical development of the E-PDAI air interfaced system and applicable IOS support.

	Document No.	Version	Status	Issued date	Location
CCSA	CCSA-S.R0113-0 v1.0	1.0	Approved	31-01-2007	http://www.ccsa.org.cn/english/tc/files.php?docpath=/ITU-T/Q.1742
TTA	TTAT.3G-S.R0113-0 V1.0	1.0	Approved	15-02-2007	http://www.tta.or.kr/standardDB/stnfile/TTAT.3G-S.R0113-0 v1.0.zip
TTC	TS-3GB-S.R0113-0V1.0	1.0	TTC Published	25-8-2006	http://www.ttc.or.jp/imt2000/ts/tssr0113-0v10.pdf

10.4.79 S.S0114-0 Version 1.0 Security Mechanisms using GBA (30 March 2006)

This document describes the profile of security mechanisms such that the mechanism can utilize keys that have been generated using the generic bootstrapping architecture (GBA). GBA is a method of providing keys in a generic manner based on the 3GPP2 authentication methods.

	Document No.	Version	Status	Issued date	Location
CCSA	CCSA-S.S0114-0 v1.0	1.0	Approved	31-01-2007	http://www.ccsa.org.cn/english/tc/files.php?docpath=/ITU-T/Q.1742
TTA	TTAT.3G-S.S0114-0 V1.0	1.0	Approved	02-15-2007	http://www.tta.or.kr/standardDB/stnfile/TTAT.3G-S.S0114-0 v1.0.zip
TTC	TS-3GB-S.S0114-0V1.0	1.0	TTC Published	02-06-2006	http://www.ttc.or.jp/imt2000/ts/tsss0114-0v10.pdf

10.4.80 S.R0115-0 Version 1.0 All-IP Network Emergency Call Support Stage 1 Requirements (14 September 2006)

This document specifies the system requirements for all-IP network emergency call support as described in [ITU-R M.1457-6]. With the introduction of VoIP in HRPD, WLAN, or other air interfaces, it is important to add support for emergency calls. The intent of this specification is to provide a general set of functionality with the flexibility needed to support variances in regional regulatory requirements.

	Document No.	Version	Status	Issued date	Location
CCSA	CCSA-S.R0115-0 v1.0	1.0	Approved	31-01-2007	http://www.ccsa.org.cn/english/tc/files.php?docpath=/ITU-T/Q.1742
TTA	TTAT.3G-S.R0115-0 V1.0	1.0	Approved	15-02-2007	http://www.tta.or.kr/standardDB/stnfile/TTAT.3G-S.R0115-0 v1.0.zip
TTC	TS-3GB-S.R0115-0V1.0	1.0	TTC Published	01-12-2006	http://www.ttc.or.jp/imt2000/ts/tssr0115-0v10.pdf

10.4.81 S.R0117-0 Version 1.0 Multimedia Priority Service (MMPS) for MMD-based Networks – Stage 1 Requirements (29 June 2006)

The scope of this document is to define the requirements for multimedia priority service for MMD-based networks.

	Document No.	Version	Status	Issued date	Location
CCSA	CCSA-S.R0117-0 v1.0	1.0	Approved	31-01-2007	http://www.ccsa.org.cn/english/tc/files.php?docpath=/ITU-T/Q.1742
TTA	TTAT.3G-S.R0117-0 V1.0	1.0	Approved	15-02-2007	http://www.tta.or.kr/standardDB/stnfile/TTAT.3G-S.R0117-0 v1.0.zip
TTC	TS-3GB-S.R0117-0V1.0	1.0	TTC Published	25-08-2006	http://www.ttc.or.jp/imt2000/ts/tssr0117-0v10.pdf

10.4.82 S.R0118-0 Version 1.0 Telephone Number Mapping (ENUM) Stage 1 Requirements (25 May 2006)

This document specifies the requirements for the development of a specification in support of Public ENUM. The requirements pertain to the content, format and meaning of information included in the ENUM NAPTR resource records associated with an E.164 number, the handling of this information by the Public ENUM name servers and the ENUM clients.

	Document No.	Version	Status	Issued date	Location
CCSA	CCSA-S.R0118-0 v1.0	1.0	Approved	31-01-2007	http://www.ccsa.org.cn/english/tc/files.php?docpath=/ITU-T/Q.1742
TTA	TTAT.3G-S.R0118-0 V1.0	1.0	Approved	15-02-2007	http://www.tta.or.kr/standardDB/stnfile/TTAT.3G-S.R0118-0 v1.0.zip
TTC	TS-3GB-S.R0118-0V1.0	1.0	TTC Published	25-08-2006	http://www.ttc.or.jp/imt2000/ts/tssr0118-0v10.pdf

10.4.83 SC.R1003-0 Version 1.0 Work Item, Stage 1 and System Requirements Process Guidelines (16 May 2002)

This 3GPP2 document is renamed from S.R0070 version 1.0. This document is to provide uniform procedures and guidance for the development, completion, distribution and approval of work items, stage 1 and system requirements across all TSGs.

	Document No.	Version	Status	Issued date	Location
CCSA	CCSA-SC.R1003-0 v1.0	1.0	Approved	31-01-2007	http://www.ccsa.org.cn/english/tc/files.php?docpath=/ITU-T/Q.1742
TTA	TS-3GB-SC.R1003-0v1.0	1.0	TTC Published	28-11-2003	http://www.ttc.or.jp/imt2000/ts/tsscr1003-0v10.pdf

10.4.84 SC.R2001-001 Version 1.0 3GPP2 System Capability Guide Release A (20 January 2000)

This document is the 3GPP2 system capability guide (SCG) for 3GPP2 wireless telecommunication systems. It is developed and maintained under the auspices of 3GPP2 TSG-S, the TSG for services and systems aspects for 3GPP2.

	Document No.	Version	Status	Issued date	Location
CCSA	CCSA-SC.R2001-001 v1.0	1.0	Approved	31-01-2007	http://www.ccsa.org.cn/english/tc/files.php?docpath=/ITU-T/Q.1742
TTA	TTAT.3G-SC.R2001-001 v1.0	1.0	Approved	15-02-2007	http://www.tta.or.kr/standardDB/stnfile/TTAT.3G-SC.R2001-001 v1.0.zip

10.4.85 SC.R2002-001 Version 1.0 3 GPP2 System Capability Guide Release B (14 June 2001)

This document is the 3GPP2 System Capability Guide (SCG) for 3GPP2 wireless telecommunication systems. It is developed and maintained under the auspices of 3GPP2 TSG-S, the TSG for services and systems aspects for 3GPP2.

	Document No.	Version	Status	Issued date	Location
CCSA	CCSA-SC.R2002-001 v1.0	1.0	Approved	31-01-2007	http://www.ccsa.org.cn/english/tc/files.php?docpath=/ITU-T/Q.1742
TTA	TTAT.3G-SC.R2002-001 v1.0	1.0	Approved	15-02-2007	http://www.tta.or.kr/standardDB/stnfile/TTAT.3G-SC.R2002-001 v1.0.zip

10.4.86 SC.R2003-002 Version 1.0 System Release Guide for the Release (Alpha) of the cdma2000 System Specifications (15 January 2004)

This 3GPP2 document is renamed from S.R0052-0 version 1.0. This document is the system release guide (SRG) for the 3GPP2 wireless telecommunication system. It is developed and maintained under the auspices of 3GPP2 TSG-S, the TSG for services and systems aspects for 3GPP2. The objective of this document is to provide an informative overview for and reference to the release (Alpha) of the 3GPP2 wireless telecommunication system (cdma2000) capabilities, features and services.

	Document No.	Version	Status	Issued date	Location
CCSA	CCSA-SC.R2003-002 v1.0	1.0	Approved	31-01-2007	http://www.ccsa.org.cn/english/tc/files.php?docpath=/ITU-T/Q.1742
TTA	TTAT.3G-SC.R2003-002 V1.0	1.0	Approved	15-02-2007	http://www.tta.or.kr/standardDB/stnfile/TTAT.3G-SC.R2003-002 v1.0.zip
TTC	TS-3GB-SC.R2003-002-0V1.0	1.0	TTC Published	08-25-2006	http://www.ttc.or.jp/imt2000/ts/tsscr2003-002-0v10.pdf

10.5 Core network specifications

10.5.1 X.S0002-0 Version 1.0 TIA/EIA-41-D Location Services Enhancements (-- March 2004)

This document presents a recommended plan for the implementation of location services enhancements for use in the wireless radiotelephone service. The purpose of this document is to specify the intersystem operations that enable a wireless system to provide enhanced location services.

	Document No.	Version	Status	Issued date	Location
CCSA	CCSA-TSD-MC-X.S0002-0 v1.0		Approved	-- 03-2004	http://www.ccsa.org.cn/english/tc/files.php?docpath=/ITU-T/Q.1742
TIA	TIA-881		Published	-- 03-2004	http://www.tiaonline.org/standards/catalog/search.cfm
TTA	TTAT.3G-X.S0002-0 V1.0	1.0	Approved	15-11-2004	http://www.tta.or.kr/standardDB/stnfile/TTAT.3G-X.S0002-0 v1.0.zip
TTC	TS-3GB-X.S0002-0V1.0	1.0	TTC Published	28-05-2004	http://www.ttc.or.jp/imt2000/ts/tsxs0002-0v10.pdf

10.5.1.1 X.S0002-0 Version 2.0 MAP Location Services Enhancements (-- May 2006)

This document presents a recommended plan for the implementation of location services enhancements for use in the wireless radiotelephone service. The purpose of this document is to specify the intersystem operations that enable a wireless system to provide enhanced location services.

	Document No.	Version	Status	Issued date	Location
CCSA	CCSA-X.S0002-0 v2.0	2.0	Approved	31-01-2007	http://www.ccsa.org.cn/english/tc/files.php?docpath=/ITU-T/Q.1742
TTA	TTAT.3G-X.S0002-0 V2.0	2.0	Approved	15-02-2007	http://www.tta.or.kr/standardDB/stnfile/TTAT.3G-X.S0002-0 v2.0.zip
TTC	TS-3GB-X.S0002-0V2.0	2.0	TTC Published	25-08-2006	http://www.ttc.or.jp/imt2000/ts/tsxs0002-0v20.pdf

10.5.2 X.S0003-0 Version 1.0 One-Way Roaming from X.S0004 to GSM (-- January 2005)

This document provides recommended ANSI/TIA/EIA-41-D enhancements required to support TIA/EIA-41 subscription identification module (SIM) roaming one-way into GSM serving areas (without modification to the GSM serving network).

	Document No.	Version	Status	Issued date	Location
CCSA	CCSA-TSD-MC-X.S0003-0	1.0	Approved	-09-2005	http://www.ccsa.org.cn/english/tc/files.php?docpath=/ITU-T/Q.1742/Q.1742.5
TIA	TIA-868		Published	-- 01-2005	http://www.tiaonline.org/standards/catalog/search.cfm
TTA	TTAT.3G-X.S0003-0 V1.0	1.0	Approved	09-12-2005	http://www.tta.or.kr/standardDB/stnfile/TTAT.3G-X.S0003-0 v1.0.zip
TTC	TS-3GB-X.S0003-0V1.0	1.0	TTC published	02-06-2005	http://www.ttc.or.jp/imt2000/ts/tsxs0003-0v10.pdf

10.5.3 X.S0004-000-E Version 1.0.0 Introduction to TIA-41 (-- March 2004)

This document is to identify those cellular services which require intersystem cooperation, to present the general background against which those services are to be provided, and to summarize the principle considerations which have governed and directed the particular approaches taken in the procedural recommendations. This part defines the range of application of the current issue of the series. It focuses on overall objectives and basic assumptions. Procedural details are presented in the other recommendations.

	Document No.	Version	Status	Issued date	Location
CCSA	CCSA-TSD-MC-X.S0004-000-E v1.0.0	1	Approved	-- 03-2004	http://www.ccsa.org.cn/english/tc/files.php?docpath=/ITU-T/Q.1742
TIA	TIA-41.000-E		Published	-- 04-2004	http://www.tiaonline.org/standards/catalog/search.cfm
TTA	TTAT.3G-X.S0004-000-E V1.0.0	1.0.0	Approved	15-11-2004	http://www.tta.or.kr/standardDB/stnfile/TTAT.3G-X.S0004-000-E v1.0.0.zip

10.5.3.1 X.S0004-000-E Version 2.0.0 Introduction to TIA-41 (-- March 2004)

The purpose of this standard is to identify those wireless services which require intersystem cooperation, to present the general background against which those services are to be provided, and to summarize the principle considerations which have governed and directed the particular approaches taken in the procedural recommendations. This part defines the range of application of the current issue of the series. It focuses on overall objectives and basic assumptions. Procedural details are presented in the other recommendations.

	Document No.	Version	Status	Issued date	Location
CCSA	CCSA-TSD-MC-X.S0004-000-E	2.0	Approved	-- 01-2006	http://www.ccsa.org.cn/english/tc/files.php?docpath=/ITU-T/Q.1742/Q.1742.5
TTA	TTAT.3G-X.S0004-000-E V2.0	2.0	Approved	19-04-2006	http://www.tta.or.kr/standardDB/stnfile/TTAT.3G-X.S0004-000-E v2.0.zip

10.5.3.2 X.S0004-000-E Version 3.0.0 Introduction to MAP (-- October 2005)

The purpose of this standard is to identify those wireless services which require intersystem cooperation, to present the general background against which those services are to be provided, and to summarize the principle considerations which have governed and directed the particular approaches taken in the procedural recommendations. This part defines the range of application of the current issue of the series. It focuses on overall objectives and basic assumptions. Procedural details are presented in the other recommendations.

	Document No.	Version	Status	Issued date	Location
CCSA	CCSA-TSD-MC-X.S0004-000-E	3.0	Approved	-- 01-2006	http://www.ccsa.org.cn/english/tc/files.php?docpath=/ITU-T/Q.1742/Q.1742.5
TTA	TTAT.3G-X.S0004-000-E V3.0	3.0	Approved	19-04-2006	http://www.tta.or.kr/standardDB/stnfile/TTAT.3G-X.S0004-000-E v3.0.zip

10.5.3.3 X.S0004-000-E Version 4.0 Mobile Application Part (MAP) – Introduction (-- May 2006)

The purpose of this standard is to identify those wireless services which require intersystem cooperation, to present the general background against which those services are to be provided, and to summarize the principle considerations which have governed and directed the particular approaches taken in the procedural recommendations. This part defines the range of application of the current issue of the series. It focuses on overall objectives and basic assumptions. Procedural details are presented in the other recommendations.

	Document No.	Version	Status	Issued date	Location
CCSA	CCSA-X.S0004-000-E v4.0	4.0	Approved	31-01-2007	http://www.ccsa.org.cn/english/tc/files.php?docpath=/ITU-T/Q.1742
TTA	TTAT.3G-X.S0004-000-E V4.0	4.0	Approved	15-02-2007	http://www.tta.or.kr/standardDB/stnfile/TAT.3G-X.S0004-000-E v4.0.zip

10.5.3.4 X.S0004-200-E Version 1.0 Mobile Application Part (MAP) – Intersystem Handoff (-- May 2006)

This specification defines intersystem handoff by describing the information flows between functional entities which occur in a number of intersystem handoff scenarios.

	Document No.	Version	Status	Issued date	Location
CCSA	CCSA-X.S0004-200-E v1.0	1.0	Approved	31-01-2007	http://www.ccsa.org.cn/english/tc/files.php?docpath=/ITU-T/Q.1742
TTA	TTAT.3G-X.S0004-200-E V1.0	1.0	Approved	15-02-2007	http://www.tta.or.kr/standardDB/stnfile/TAT.3G-X.S0004-200-E v1.0.zip

10.5.3.5 X.S0004-290-E Version 1.0 Mobile Application Part (MAP) – Intersystem Handoff Annexes (-- May 2006)

This annex is normative and is considered part of the specification.

	Document No.	Version	Status	Issued date	Location
CCSA	CCSA-X.S0004-290-E v1.0	1.0	Approved	31-01-2007	http://www.ccsa.org.cn/english/tc/files.php?docpath=/ITU-T/Q.1742
TTA	TTAT.3G-X.S0004-290-E V1.0	1.0	Approved	15-02-2007	http://www.tta.or.kr/standardDB/stnfile/TAT.3G-X.S0004-290-E v1.0.zip

10.5.3.6 X.S0004-400-E Version 1.0 Operations, Administration and Maintenance (-- July 2005)

This document defines the intersystem operations, administration and maintenance (OA&M) information flows and procedures required for intersystem trunk maintenance.

	Document No.	Version	Status	Issued date	Location
CCSA	CCSA-TSD-MC-X.S0004-400-E	1.0	Approved	-- 01-2006	http://www.ccsa.org.cn/english/tc/files.php?docpath=/ITU-T/Q.1742/Q.1742.5
TIA	TIA-41.400-E		Published	-- 12-2005	http://www.tiaonline.org/standards/catalog/search.cfm
TTA	TTAT.3G-X.S0004-400-E V1.0	1.0	Approved	19-04-2006	http://www.tta.or.kr/standardDB/stnfile/TAT.3G-X.S0004-400-E v1.0.zip

10.5.3.7 X.S0004-500-E Version 1.0.0 Introduction to Signaling Protocols (-- March 2004)

This document introduces the signalling protocols for this standard.

	Document No.	Version	Status	Issued date	Location
CCSA	CCSA-TSD-MC-X.S0004-500-E v1.0.0	1	Approved	-- 03-2004	http://www.ccsa.org.cn/english/tc/files.php?docpath=/ITU-T/Q.1742
TIA	TIA-41.500-E		Published	-- 04-2004	http://www.tiaonline.org/standards/catalog/search.cfm
TTA	TTAT.3G-X.S0004-500-E V1.0.0	1.0.0	Approved	15-11-2004	http://www.tta.or.kr/standardDB/stnfile/TAT.3G-X.S0004-500-E v1.0.0.zip

10.5.3.8 X.S0004-510-E Version 1.0.0 X.25 Transport Signaling Protocols (-- March 2004)

This document describes X.25 transport signalling protocols.

	Document No.	Version	Status	Issued date	Location
CCSA	CCSA-TSD-MC-X.S0004-510-E v1.0.0	1	Approved	-- 03-2004	http://www.ccsa.org.cn/english/tc/files.php?docpath=/ITU-T/Q.1742
TIA	TIA-41.510-E		Published	-- 04-2004	http://www.tiaonline.org/standards/catalog/search.cfm
TTA	TTAT.3G-X.S0004-510-E V1.0.0	1.0.0	Approved	15-11-2004	http://www.tta.or.kr/standardDB/stnfile/TAT.3G-X.S0004-510-E v1.0.0.zip

10.5.3.9 X.S0004-511-E Version 1.0.0 ANS/SS7 Transport Signaling Protocols (-- March 2004)

This document describes ANS/SS7 transport signalling protocols.

	Document No.	Version	Status	Issued date	Location
CCSA	CCSA-TSD-MC-X.S0004-511-E v1.0.0	1	Approved	-- 03-2004	http://www.ccsa.org.cn/english/tc/files.php?docpath=/ITU-T/Q.1742
TIA	TIA-41.511-E		Published	-- 04-2004	http://www.tiaonline.org/standards/catalog/search.cfm
TTA	TTAT.3G-X.S0004-511-E V1.0.0	1.0.0	Approved	15-11-2004	http://www.tta.or.kr/standardDB/stnfile/TAT.3G-X.S0004-511-E v1.0.0.zip

10.5.3.10 X.S0004-512-E Version 1.0.0 ITU-T SS7 Transport Signaling Protocols (-- March 2004)

This document describes ITU-T SS7 transport signalling protocols.

	Document No.	Version	Status	Issued date	Location
CCSA	CCSA-TSD-MC-X.S0004-512-E V1.0.0	1	Approved	-- 03-2004	http://www.ccsa.org.cn/english/tc/files.php?docpath=/ITU-T/Q.1742
TIA	TIA-41.512.-E		Published	-- 04-2004	http://www.tiaonline.org/standards/catalog/search.cfm
TTA	TTAT.3G-X.S0004-512-E V1.0.0	1.0.0	Approved	15-11-2004	http://www.tta.or.kr/standardDB/stnfile/TAT.3G-X.S0004-512-E v1.0.0.zip

10.5.3.11 X.S0004-520-E Version 1.0.0 TCAP Application Signaling Protocols (-- March 2004)

This document describes TCAP application signalling protocols.

	Document No.	Version	Status	Issued date	Location
CCSA	CCSA-TSD-MC-X.S0004-520-E v1.0.0	1	Approved	-- 03-2004	http://www.ccsa.org.cn/english/tc/files.php?docpath=/ITU-T/Q.1742
TIA	TIA-41.520-E		Published	-- 04-2004	http://www.tiaonline.org/standards/catalog/search.cfm
TTA	TTAT.3G-X.S0004-520-E V1.0.0	1.0.0	Approved	15-11-2004	http://www.tta.or.kr/standardDB/stnfile/TAT.3G-X.S0004-520-E v1.0.0.zip

10.5.3.12 X.S0004-540-E Version 1.0.0 MAP Operations Signaling Protocols (-- March 2004)

This document supports systems conforming to air-interface technology, AMPS, NAMPS, TDMA, CDMA, including cdma2000.

	Document No.	Version	Status	Issued date	Location
CCSA	CCSA-TSD-MC-X.S0004-540-E V1.0.0	1	Approved	-- 03-2004	http://www.ccsa.org.cn/english/tc/files.php?docpath=/ITU-T/Q.1742
TIA	TIA-41.540-E		Published	-- 04-2004	http://www.tiaonline.org/standards/catalog/search.cfm
TTA	TTAT.3G-X.S0004-540-E V1.0.0	1.0.0	Approved	15-11-2004	http://www.tta.or.kr/standardDB/stnfile/TAT.3G-X.S0004-540-E v1.0.0.zip

10.5.3.13 X.S0004-550-E Version 1.0.0 MAP Parameters Signaling Protocols (-- March 2004)

This document supports systems conforming to air-interface technology, AMPS, NAMPS, TDMA, CDMA, including cdma2000.

	Document No.	Version	Status	Issued date	Location
CCSA	CCSA-TSD-MC-X.S0004-550-E V1.0.0	1	Approved	-- 03-2004	http://www.ccsa.org.cn/english/tc/files.php?docpath=/ITU-T/Q.1742
TIA	TIA-41.550-E		Published	-- 04-2004	http://www.tiaonline.org/standards/catalog/search.cfm
TTA	TTAT.3G-X.S0004-550-E V1.0.0	1.0.0	Approved	15-11-2004	http://www.tta.or.kr/standardDB/stnfile/TAT.3G-X.S0004-550-E v1.0.0.zip

10.5.3.14 X.S0004-551-E Version 1.0.0 Parameter Types Signaling Protocols (-- March 2004)

This document provides the definitions of the parameter types used in this standard.

	Document No.	Version	Status	Issued date	Location
CCSA	CCSA-TSD-MC-X.S0004-551-E V1.0.0	1	Approved	-- 03-2004	http://www.ccsa.org.cn/english/tc/files.php?docpath=/ITU-T/Q.1742
TIA	TIA-41.551-E		Published	-- 04-2004	http://www.tiaonline.org/standards/catalog/search.cfm
TTA	TTAT.3G-X.S0004-551-E V1.0.0	1.0.0	Approved	15-11-2004	http://www.tta.or.kr/standardDB/stnfile/TAT.3G-X.S0004-551-E v1.0.0.zip

10.5.3.15 X.S0004-590-E Version 1.0.0 MAP Compatibility Signaling Protocols (-- March 2004)

While this document outlines guidelines and rules, which will in the near term be beneficial to implementation of this standard, other activities which may impact these rules are in progress. As such, the remainder of the section "MAP compatibility guidelines and rules" may be subject to change and revision. This is to ensure that there is no long-term impediment to cellular radiotelecommunication networks to evolve and implement significant new functionality.

	Document No.	Version	Status	Issued date	Location
CCSA	CCSA-TSD-MC-X.S0004-590-E V1.0.0	1	Approved	-- 03-2004	http://www.ccsa.org.cn/english/tc/files.php?docpath=/ITU-T/Q.1742
TIA	TIA-41.590-E		Published	-- 04-2004	http://www.tiaonline.org/standards/catalog/search.cfm
TTA	TTAT.3G-X.S0004-590-E V1.0.0	1.0.0	Approved	15-11-2004	http://www.tta.or.kr/standardDB/stnfile/TAT.3G-X.S0004-590-E v1.0.0.zip

10.5.3.16 X.S0004-600-E Version 1.0 Introduction to Procedures (-- July 2005)

This document describes the signalling and call processing procedures required to perform automatic roaming features and services. The messages required to perform the automatic roaming

are defined in Part 540. Conformance with this document shall mean that a system's externally visible behaviour is the same as the externally visible behaviour of the abstract system described here.

	Document No.	Version	Status	Issued date	Location
CCSA	CCSA-TSD-MC-X.S0004-600-E	1.0	Approved	-01-2006	http://www.ccsa.org.cn/english/tc/files.php?docpath=/ITU-T/Q.1742/Q.1742.5
TIA	TIA-41.600-E		Published	-- 12-2005	http://www.tiaonline.org/standards/catalog/search.cfm
TTA	TTAT.3G-X.S0004-600-E V1.0	1.0	Approved	19-04-2006	http://www.tta.or.kr/standardDB/stnfile/TAT.3G-X.S0004-600-E v1.0.zip

10.5.3.17 X.S0004-630-E Version 1.0 Basic Call Processing (-- July 2005)

This document describes the signalling and call processing procedures required to perform automatic roaming features and services.

	Document No.	Version	Status	Issued date	Location
CCSA	CCSA-TSD-MC-X.S0004-630-E	1.0	Approved	-01-2006	http://www.ccsa.org.cn/english/tc/files.php?docpath=/ITU-T/Q.1742/Q.1742.5
TIA	TIA-41.630-E		Published	-- 12-2005	http://www.tiaonline.org/standards/catalog/search.cfm
TTA	TTAT.3G-X.S0004-630-E V1.0	1.0	Approved	19-04-2006	http://www.tta.or.kr/standardDB/stnfile/TAT.3G-X.S0004-630-E v1.0.zip

10.5.3.18 X.S0004-640-E Version 1.0 Intersystem Procedures (-- July 2005)

This document describes the signalling and call processing procedures required to perform automatic roaming features and services.

	Document No.	Version	Status	Issued date	Location
CCSA	CCSA-TSD-MC-X.S0004-640-E	1.0	Approved	-01-2006	http://www.ccsa.org.cn/english/tc/files.php?docpath=/ITU-T/Q.1742/Q.1742.5
TIA	TIA-41.640-E		Published	-- 12-2006	http://www.tiaonline.org/standards/catalog/search.cfm
TTA	TTAT.3G-X.S0004-640-E V1.0	1.0	Approved	19-04-2006	http://www.tta.or.kr/standardDB/stnfile/TAT.3G-X.S0004-640-E v1.0.zip

10.5.3.19 X.S0004-641-E Version 1.0 Short Message Services (SMS) (-- July 2005)

This document describes the signalling and call processing procedures required to perform automatic roaming features and services.

	Document No.	Version	Status	Issued date	Location
CCSA	CCSA-TSD-MC-X.S0004-641-E	1.0	Approved	-01-2006	http://www.ccsa.org.cn/english/tc/files.php?docpath=/ITU-T/Q.1742/Q.1742.5
TIA	TIA-41.641-E		Published	-- 12-2006	http://www.tiaonline.org/standards/catalog/search.cfm
TTA	TTAT.3G-X.S0004-641-E V1.0	1.0	Approved	19-04-2006	http://www.tta.or.kr/standardDB/stnfile/TAT.3G-X.S0004-641-E v1.0.zip

10.5.3.20 X.S0004-642-E Version 1.0 Segmentation (-- July 2005)

This section describes procedures to allow the transmission of messages, which may or may not require segmentation and reassembly (S&R).

	Document No.	Version	Status	Issued date	Location
CCSA	CCSA-TSD-MC-X.S0004-642-E	1.0	Approved	-01-2006	http://www.ccsa.org.cn/english/tc/files.php?docpath=/ITU-T/Q.1742/Q.1742.5
TIA	TIA-41.642-E		Published	-- 12-2005	http://www.tiaonline.org/standards/catalog/search.cfm
TTA	TTAT.3G-X.S0004-642-E V1.0	1.0	Approved	19-04-2006	http://www.tta.or.kr/standardDB/stnfile/TTAT.3G-X.S0004-642-E v1.0.zip

10.5.3.21 X.S0004-650-E Version 1.0 Common Voice Feature Procedures (-- July 2005)

This section describes common voice feature procedures to implement individual features.

	Document No.	Version	Status	Issued date	Location
CCSA	CCSA-TSD-MC-X.S0004-650-E	1.0	Approved	-01-2006	http://www.ccsa.org.cn/english/tc/files.php?docpath=/ITU-T/Q.1742/Q.1742.5
TIA	TIA-41.650-E		Published	-- 12-2005	http://www.tiaonline.org/standards/catalog/search.cfm
TTA	TTAT.3G-X.S0004-650-E V1.0	1.0	Approved	19-04-2006	http://www.tta.or.kr/standardDB/stnfile/TTAT.3G-X.S0004-650-E v1.0.zip

10.5.3.22 X.S0004-651-E Version 1.0 Voice Feature Procedures (-- July 2005)

This section describes modular procedures to implement individual features.

	Document No.	Version	Status	Issued date	Location
CCSA	CCSA-TSD-MC-X.S0004-651-E	1.0	Approved	-01-2006	http://www.ccsa.org.cn/english/tc/files.php?docpath=/ITU-T/Q.1742/Q.1742.5
TIA	TIA-41.651-E		Published	-- 12-2005	http://www.tiaonline.org/standards/catalog/search.cfm
TTA	TTAT.3G-X.S0004-651-E V1.0	1.0	Approved	19-04-2006	http://www.tta.or.kr/standardDB/stnfile/TTAT.3G-X.S0004-651-E v1.0.zip

10.5.3.23 X.S0004-660-E Version 1.0 Wireless Intelligent Network (WIN) Procedures (-- July 2005)

In addition to the specific procedures described in this part of the standard, the functional entity call and service logic processing models provide a tool used by WIN architects to model a call and to understand and describe the distribution of functions between functional entities and functional entity relationships.

	Document No.	Version	Status	Issued date	Location
CCSA	CCSA-TSD-MC-X.S0004-660-E	1.0	Approved	-01-2006	http://www.ccsa.org.cn/english/tc/files.php?docpath=/ITU-T/Q.1742/Q.1742.5
TIA	TIA-41.660-E		Published	-- 12-2005	http://www.tiaonline.org/standards/catalog/search.cfm
TTA	TTAT.3G-X.S0004-660-E V1.0	1.0	Approved	19-04-2006	http://www.tta.or.kr/standardDB/stnfile/TTAT.3G-X.S0004-660-E v1.0.zip

10.5.3.24 X.S0004-690-E Version 1.0 Operation Timer Values (-- July 2005)

The following references provide a summary of the timers used for MAP operations. The timer values specified are default values only and should be optimized for actual operating environments. Some timers are locally defined and are not in this table (e.g., alerting timer, no answer timer, page response timer, maximum interaction timer, interdigit timer).

	Document No.	Version	Status	Issued date	Location
CCSA	CCSA-TSD-MC-X.S0004-690-E	1.0	Approved	-01-2006	http://www.ccsa.org.cn/english/tc/files.php?docpath=/ITU-T/Q.1742/Q.1742.5
TIA	TIA-41.690-E		Published	-- 12-2005	http://www.tiaonline.org/standards/catalog/search.cfm
TTA	TTAT.3G-X.S0004-690-E V1.0	1.0	Approved	19-04-2006	http://www.tta.or.kr/standardDB/stnfile/TTAT.3G-X.S0004-690-E v1.0.zip

10.5.3.25 X.S0004-691-E Version 1.0 Annexes (-- July 2005)

This annex describes an algorithm for verifying the value of RANDC received from an MS. The algorithm used to verify RANDC is internal to an MSC and, as such, it does not constitute an intersystem operation.

	Document No.	Version	Status	Issued date	Location
CCSA	CCSA-TSD-MC-X.S0004-691-E	1.0	Approved	-- 01-2006	http://www.ccsa.org.cn/english/tc/files.php?docpath=/ITU-T/Q.1742/Q.1742.
TTA	TTAT.3G-X.S0004-691-E V1.0	1.0	Approved	19-04-2006	http://www.tta.or.kr/standardDB/stnfile/TTAT.3G-X.S0004-691-E v1.0.zip

10.5.3.26 X.S0004-691-E Version 2.0 Annexes (-- September 2005)

This annex describes an algorithm for verifying the value of RANDC received from an MS. The algorithm used to verify RANDC is internal to an MSC and, as such, it does not constitute an intersystem operation.

	Document No.	Version	Status	Issued date	Location
CCSA	CCSA-TSD-MC-X.S0004-691-E	2.0	Approved	-- 01-2006	http://www.ccsa.org.cn/english/tc/files.php?docpath=/ITU-T/Q.1742/Q.1742.
TTA	TTAT.3G-X.S0004-691-E V2.0	2.0	Approved	19-04-2006	http://www.tta.or.kr/standardDB/stnfile/TTAT.3G-X.S0004-691-E v2.0.zip

10.5.3.27 X.S0004-700-E Version 1.0.0 Wireless Intelligent Networks (-- March 2004)

This document part of TIA-41 defines the distributed functional plane (DFP) for the wireless intelligent network (WIN).

Specifically, the scope of this part of the standard is:

- 1) To define the WIN functional entities and the relationships applicable to WIN.
- 2) To specify a high-level model description of call control function (CCF) activities required to establish and maintain communication paths for users.
- 3) To specify a high-level model description of service switching function (SSF) activities required for interaction between the CCF and a session control function (SCF).
- 4) To specify WIN triggers and provide a high level model description of detection point processing.
- 5) To describe mobility management and radio access control functions in the context of WIN.
- 6) To illustrate how the WIN basic call state models interact with TIA-41 signalling.

	Document No.	Version	Status	Issued date	Location
CCSA	CCSA-TSD-MC-X.S0004-700-E V1.0.0	1	Approved	-- 03-2004	http://www.ccsa.org.cn/english/tc/files.php?docpath=/ITU-T/Q.1742
TIA	TIA-41.700-E		Published	-- 04-2004	http://www.tiaonline.org/standards/catalog/search.cfm
TTA	TTAT.3G-X.S0004-700-E V1.0.0	1.0.0	Approved	15-11-2004	http://www.tta.or.kr/standardDB/stnfile/TTAT.3G-X.S0004-700-E v1.0.0.zip

10.5.3.28 X.S0004-730-E Version 1.0.0 WIN Distributed Functional Model (-- March 2004)

This document depicts the functional entities and relationships applicable to WIN.

	Document No.	Version	Status	Issued date	Location
CCSA	CCSA-TSD-MC-X.S0004-730-E V1.0.0	1	Approved	-- 03-2004	http://www.ccsa.org.cn/english/tc/files.php?docpath=/ITU-T/Q.1742
TIA	TIA-41.730-E		Published	-- 04-2004	http://www.tiaonline.org/standards/catalog/search.cfm
TTA	TTAT.3G-X.S0004-730-E V1.0.0	1.0.0	Approved	15-11-2004	http://www.tta.or.kr/standardDB/stnfile/TTAT.3G-X.S0004-730-E v1.0.0.zip

10.5.3.29 X.S0004-750-E Version 1.0.0 SSF/CCF Call and Service Logic Model (-- March 2004)

This document describes WIN call and service logic processing in terms of call modelling and modelling of service logic processing. WIN call and service logic encompasses call and connection processing in the SSF/CCF, service logic execution in the SCF, and the use of supporting resources and data in the SRF and SDF, respectively.

	Document No.	Version	Status	Issued date	Location
CCSA	CCSA-TSD-MC-X.S0004-750-E V1.0.0	1	Approved	-- 03-2004	http://www.ccsa.org.cn/english/tc/files.php?docpath=/ITU-T/Q.1742
TIA	TIA-41.750-E		Published	-- 04-2004	http://www.tiaonline.org/standards/catalog/search.cfm
TTA	TTAT.3G-X.S0004-750-E V1.0.0	1.0.0	Approved	15-11-2004	http://www.tta.or.kr/standardDB/stnfile/TTAT.3G-X.S0004-750-E v1.0.0.zip

10.5.3.30 X.S0004-790-E Version 1.0.0 WIN Call Delivery (-- March 2004)

These annexes describe how MS-to-MS call delivery can be modelled using the WIN basic call state models (BCSMs). The message sequences shown in the annex are as in TIA-41.

	Document No.	Version	Status	Issued date	Location
CCSA	CCSA-TSD-MC-X.S0004-790-E V1.0.0	1	Approved	-- 03-2004	http://www.ccsa.org.cn/english/tc/files.php?docpath=/ITU-T/Q.1742
TIA	TIA-41.790-E		Published	-- 04-2004	http://www.tiaonline.org/standards/catalog/search.cfm
TTA	TTAT.3G-X.S0004-790-E V1.0.0	1.0.0	Approved	15-11-2004	http://www.tta.or.kr/standardDB/stnfile/TTAT.3G-X.S0004-790-E v1.0.0.zip

10.5.4 X.S0006-0 Version 1.0 Map Support of Authentication and Key Agreement (AKA) (-- October 2005)

Enhanced subscriber authentication (ESA) uses 3GPP authentication and key agreement (AKA) procedures for mutual authentication of the MS and the network in the serving system. The successful execution of AKA results in the establishment of a security association (i.e., a set of

security data) between the MS and the serving system. This enables a set of security services to be provided (e.g., data integrity of a signalling message, signalling information element encryption, user data encryption).

	Document No.	Version	Status	Issued date	Location
CCSA	CCSA-X.S0006-0 v1.0	1.0	Approved	31-01-2007	http://www.ccsa.org.cn/english/tc/files.php?docpath=/ITU-T/Q.1742
TTA	TTAT.3G-X.S0006-0 V1.0	1.0	Approved	15-02-2007	http://www.tta.or.kr/standardDB/stnfile/TAT.3G-X.S0006-0 v1.0.zip
TTC	TS-3GB-X.S0006-0V1.0	1.0	TTC Published	03-03-2006	http://www.ttc.or.jp/imt2000/ts/tsxs0006-0v10.pdf

10.5.5 X.S0008-0 Version 1.0 Support for the Mobile Equipment Identity (MEID) (-- June 2004)

TIA-41 support for the mobile equipment identity (MEID).

	Document No.	Version	Status	Issued date	Location
CCSA	CCSA-TSD-MC-X.S0008-0	1.0	Approved	-09-2005	http://www.ccsa.org.cn/english/tc/files.php?docpath=/ITU-T/Q.1742/Q.1742.5
TIA	TIA-928-1		Published	-- 06-2005	http://www.tiaonline.org/standards/catalog/search.cfm
TTA	TTAT.3G-X.S0008-0 V1.0	1.0	Approved	09-12-2005	http://www.tta.or.kr/standardDB/stnfile/TAT.3G-X.S0008-0 v1.0.zip
TTC	TS-3GB-X.S0008-0V1.0	1.0	TTC published	03-09-2004	http://www.ttc.or.jp/imt2000/ts/tsxs0008-0v10.pdf

10.5.5.1 X.S0008-0 Version 2.0 Map Support for the Mobile Equipment Identity (MEID) (-- October 2005)

TIA-41 support for the mobile equipment identity (MEID).

	Document No.	Version	Status	Issued date	Location
CCSA	CCSA-TSD-MC-X.S0008-0	2.0	Approved	-01-2006	http://www.ccsa.org.cn/english/tc/files.php?docpath=/ITU-T/Q.1742/Q.1742.5
TIA	TIA-928-2[E]		Published	-- 01-2006	http://www.tiaonline.org/standards/catalog/search.cfm
TTA	TTAT.3G-X.S0008-0 V2.0	2.0	Approved	19-04-2006	http://www.tta.or.kr/standardDB/stnfile/TAT.3G-X.S0008-0 v2.0.zip
TTC	TS-3GB-X.S0008-0V2.0	2.0	TTC Published	25-11-2005	http://www.ttc.or.jp/imt2000/ts/tsxs0008-0v20.pdf

10.5.6 X.S0009-0 Version 1.0 Wireless Intelligent Network Support for Location Based Services (-- June 2004)

The purpose of this document is to describe FAM, LBC, LBIS and ECR, and to specify the intersystem operations that enable a wireless system to provide these location-based services.

	Document No.	Version	Status	Issued date	Location
CCSA	CCSA-TSD-MC-X.S0009-0	1.0	Approved	-09-2005	http://www.ccsa.org.cn/english/tc/files.php?docpath=/ITU-T/Q.1742/Q.1742.5
TIA	TIA-843		Published	-- 08-2004	http://www.tiaonline.org/standards/catalog/search.cfm
TTA	TTAT.3G-X.S0009-0 V1.0	1.0	Approved	09-12-2005	http://www.tta.or.kr/standardDB/stnfile/TTAT.3G-X.S0009-0 v1.0.zip
TTC	TS-3GB-X.S0009-0V1.0	1.0	TTC published	03-09-2004	http://www.ttc.or.jp/imt2000/ts/tsxs0009-0v10.pdf

10.5.7 X.S0010-A Version 1.0 Pre-Paid Charging Enhancements for Circuit-Switched Data and Short Message Services (05 January 2004)

This document describes the additions and modifications to TIA/EIA/IS-826, wireless intelligent network capabilities for pre-paid charging, to support circuit-switched data and short message services.

	Document No.	Version	Status	Issued date	Location
CCSA	CCSA-TSD-MC-X.S0010-A v1.0	1	Approved	05-01-2004	http://www.ccsa.org.cn/english/tc/files.php?docpath=/ITU-T/Q.1742
TIA	TIA-826-A		Published	-- 12-2003	http://www.tiaonline.org/standards/catalog/search.cfm
TTA	TTAT.3G-X.S0010-A V1.0	1.0	Approved	15-11-2004	http://www.tta.or.kr/standardDB/stnfile/TTAT.3G-X.S0010-A v1.0.zip
TTC	TS-3GB-X.S0010-AV1.0	1.0	TTC Published	28-05-2004	http://www.ttc.or.jp/imt2000/ts/tsxs0010-av10.pdf

10.5.8 X.S0011-001-C Version 1.0.0 cdma2000 Wireless IP Network Standard: Introduction (-- August 2003)

This specification defines requirements for support of wireless packet data networking capability on a third generation wireless system based on cdma2000. This specification defines the two methods for accessing public networks (Internet) and private networks (intranets): simple IP and mobile IP. It describes the required quality of service, security, mobility management and accounting capabilities needed to support both methods.

	Document No.	Version	Status	Issued date	Location
CCSA	CCSA-TSD-MC-X.S0011-001-C v1.0.0	1	Approved	-- 08-2003	http://www.ccsa.org.cn/english/tc/files.php?docpath=/ITU-T/Q.1742
TIA	TIA-835-C		Published	-- 08-2003	http://www.tiaonline.org/standards/catalog/search.cfm
TTA	TTAT.3G-X.S0011-001-C V1.0.0	1.0.0	Approved	15-11-2004	http://www.tta.or.kr/standardDB/stnfile/TTAT.3G-X.S0011-001-C v1.0.0.zip
TTC	TS-3GB-X.S0011-001-Cv1.0.0	1.0.0	TTC published	28-11-2003	http://www.ttc.or.jp/imt2000/ts/tsxs0011-001-cv100.pdf

10.5.8.1 X.S0011-001-C Version 2.0 cdma2000 Wireless IP Network Standard: Introduction (-- July 2005)

This specification defines requirements for support of wireless packet data networking capability on a third generation wireless system based on cdma2000. This specification supports the services and architecture. This specification defines the two methods for accessing public networks (Internet) and private networks (intranets): simple IP and mobile IP. It describes the required quality of service, security, mobility management and accounting capabilities needed to support both methods.

	Document No.	Version	Status	Issued date	Location
CCSA	CCSA-TSD-MC-X.S0011-001-C	2.0	Approved	-- 01-2006	http://www.ccsa.org.cn/english/tc/files.php?docpath=/ITU-T/Q.1742/Q.1742
TTA	TTAT.3G-X.S0011-001-C V2.0	2.0	Approved	19-04-2006	http://www.tta.or.kr/standardDB/stnfile/TTAT.3G-X.S0011-001-C v2.0.zip
TTC	TS-3GB-X.S0011-001-Cv2.0	2.0	TTC Published	26-08-2006	http://www.ttc.or.jp/imt2000/ts/tsxs0011-001-cv20.pdf

10.5.8.2 X.S0011-001-C Version 3.0 cdma2000 Wireless IP Network Standard: Introduction (-- October 2006)

This specification defines requirements for support of wireless packet data networking capability on a third generation wireless system based on cdma2000. This specification supports the services and architecture. This specification defines the two methods for accessing public networks (Internet) and private networks (intranets): simple IP and mobile IP. It describes the required quality of service, security, mobility management and accounting capabilities needed to support both methods.

	Document No.	Version	Status	Issued date	Location
CCSA	CCSA-X.S0011-001-C v3.0	3.0	Approved	31-01-2007	http://www.ccsa.org.cn/english/tc/files.php?docpath=/ITU-T/Q.1742
TTA	TTAT.3G-X.S0011-001-C V3.0	3.0	Approved	15-02-2007	http://www.tta.or.kr/standardDB/stnfile/TTAT.3G-X.S0011-001-C v3.0.zip
TTC	TS-3GB-X.S0011-001-Cv3.0	3.0	TTC Published	23-02-2007	http://www.ttc.or.jp/imt2000/ts/tsxs0011-001-cv30.pdf

10.5.8.3 X.S0011-001-D Version 1.0 cdma2000 Wireless IP Network Standard: Introduction (-- February 2006)

This specification defines requirements for support of wireless packet data networking capability on a third generation wireless system based on cdma2000. This specification supports the services and architecture. This specification defines the two methods for accessing public networks (Internet) and private networks (intranets): simple IP and mobile IP. It describes the required quality of service, security, mobility management and accounting capabilities needed to support both methods.

	Document No.	Version	Status	Issued date	Location
CCSA	CCSA-X.S0011-001-D v1.0	1.0	Approved	31-01-2007	http://www.ccsa.org.cn/english/tc/files.php?docpath=/ITU-T/Q.1742
TTA	TTAT.3G-X.S0011-001-D V1.0	1.0	Approved	15-02-2007	http://www.tta.or.kr/standardDB/stnfile/TTAT.3G-X.S0011-001-D v1.0.zip
TTC	TS-3GB-X.S0011-001-Dv1.0	1.0	TTC Published	02-06-2006	http://www.ttc.or.jp/imt2000/ts/tsxs0011-001-dv10.pdf

10.5.8.4 X.S0011-002-C Version 1.0.0 cdma2000 Wireless IP Network Standard: Simple IP and Mobile IP Access Services (-- August 2003)

This document describes the required capabilities at the MS, the PDSN, the HA and the RADIUS servers to provide simple IPv4, simple IPv6 and mobile IPv4 access services over PPP. It describes the mechanisms of updating the DNS with the user's assigned IP address as described in the IP reachability service capability.

	Document No.	Version	Status	Issued date	Location
CCSA	CCSA-TSD-MC-X.S0011-002-C v1.0.0	1	Approved	-- 08-03	http://www.ccsa.org.cn/english/tc/files.php?docpath=/ITU-T/Q.1742
TIA	TIA-835-C		Published	-- 08-2003	http://www.tiaonline.org/standards/catalog/search.cfm
TTA	TTAT.3G-X.S0011-002-C V1.0.0	1.0.0	Approved	15-11-2004	http://www.tta.or.kr/standardDB/stnfile/TTAT.3G-X.S0011-002-C v1.0.0.zip
TTC	TS-3GB-X.S0011-002-Cv1.0.0	1.0.0	TTC published	28-11-2003	http://www.ttc.or.jp/imt2000/ts/tsxs0011-002-cv100.pdf

10.5.8.5 X.S0011-002-C Version 2.0 cdma2000 Wireless IP Network Standard: Simple IP and Mobile IP Services (-- July 2005)

This document describes the required capabilities at the MS, the PDSN, the HA and the RADIUS servers to provide simple IPv4, simple IPv6 and mobile IPv4 access services over PPP. It describes the mechanisms of updating the DNS with the user's assigned IP address as described in the IP reachability service capability.

	Document No.	Version	Status	Issued date	Location
CCSA	CCSA-TSD-MC-X.S0011-002-C	2.0	Approved	-- 01-2006	http://www.ccsa.org.cn/english/tc/files.php?docpath=/ITU-T/Q.1742/Q.1742
TTA	TTAT.3G-X.S0011-002-C V2.0	2.0	Approved	19-04-2006	http://www.tta.or.kr/standardDB/stnfile/TTAT.3G-X.S0011-002-C v2.0.zip
TTC	TS-3GB-X.S0011-002-Cv2.0	2.0	TTC Published	26-08-2006	http://www.ttc.or.jp/imt2000/ts/tsxs0011-002-cv20.pdf

10.5.8.6 X.S0011-002-C Version 3.0 cdma2000 Wireless IP Network Standard: Simple IP and Mobile IP Services (-- October 2006)

This document describes the required capabilities at the MS, the PDSN, the HA and the RADIUS servers to provide Simple IPv4, simple IPv6 and mobile IPv4 access services over PPP. It describes the mechanisms of updating the DNS with the user's assigned IP address as described in the IP reachability service capability.

	Document No.	Version	Status	Issued date	Location
CCSA	CCSA-X.S0011-002-C v3.0	3.0	Approved	31-01-2007	http://www.ccsa.org.cn/english/tc/files.php?docpath=/ITU-T/Q.1742
TTA	TTAT.3G-X.S0011-002-C V3.0	3.0	Approved	15-02-2007	http://www.tta.or.kr/standardDB/stnfile/TTAT.3G-X.S0011-002-C v3.0.zip
TTC	TS-3GB-X.S0011-002-Cv3.0	3.0	TTC Published	23-02-2007	http://www.ttc.or.jp/imt2000/ts/tsxs0011-002-cv30.pdf

10.5.8.7 X.S0011-002-D Version 1.0 cdma2000 Wireless IP Network Standard: Simple IP and Mobile IP Access Services (-- February 2006)

This document describes the basic IP access services: simple IPv4/IPv6, MIP6 and MIP4 with home agent (HA) and/or dynamic home IP address assignment. It also addresses the security requirements between the wireless IP network nodes: PDSN, HA and RADIUS servers.

	Document No.	Version	Status	Issued date	Location
CCSA	CCSA-X.S0011-002-D v1.0	1.0	Approved	31-01-2007	http://www.ccsa.org.cn/english/tc/files.php?docpath=/ITU-T/Q.1742
TTA	TTAT.3G-X.S0011-002-D V1.0	1.0	Approved	15-02-2007	http://www.tta.or.kr/standardDB/stnfile/TAT.3G-X.S0011-002-D v1.0.zip
TTC	TS-3GB-X.S0011-002-Dv1.0	1.0	TTC Published	02-06-2006	http://www.ttc.or.jp/imt2000/ts/tsxs0011-002-dv10.pdf

10.5.8.8 X.S0011-003-C Version 1.0.0 cdma2000 Wireless IP Network Standard: Packet Data Mobility and Resource Management (-- August 2003)

This document describes the mechanisms at the PDSN resulting from handoff of an MS from one BS/PCF to another BS/PCF, and which may result in changing the serving PDSN for the MS. This chapter describes an optional fast handoff capability, which is a low latency, low data loss handoff mechanism between PDSNs. Fast handoff mechanism delays re-negotiation of PPP until the MS becomes dormant at the Target PDSN. This document also describes resource management procedures at the PDSN and the HA that are used following an inter PDSN handoff or under other conditions that require release of resources. Furthermore, a procedure for provisioning the RAN with resource management parameters such as RN packet data inactivity timers is specified in this document.

	Document No.	Version	Status	Issued date	Location
CCSA	CCSA-TSD-MC-X.S0011-003-C v1.0.0	1	Approved	-- 08-2003	http://www.ccsa.org.cn/english/tc/files.php?docpath=/ITU-T/Q.1742
TIA	TIA-835-C		Published	-- 08-2003	http://www.tiaonline.org/standards/catalog/search.cfm
TTA	TTAT.3G-X.S0011-003-C V1.0.0	1.0.0	Approved	15-11-2004	http://www.tta.or.kr/standardDB/stnfile/TAT.3G-X.S0011-003-C v1.0.0.zip
TTC	TS-3GB-X.S0011-003-Cv1.0.0	1.0.0	TTC published	28-11-2003	http://www.ttc.or.jp/imt2000/ts/tsxs0011-003-cv100.pdf

10.5.8.9 X.S0011-003-C Version 2.0 cdma2000 Wireless IP Network Standard: Packet Data Mobility and Resource Management (-- July 2005)

This document describes the mechanisms at the PDSN resulting from handoff of an MS from one BS/PCF to another BS/PCF, and which may result in changing the serving PDSN for the MS. This document describes an optional fast handoff capability, which is a low latency, low data loss handoff mechanism between PDSNs. Fast handoff mechanism delays re-negotiation of PPP until the MS becomes dormant at the Target PDSN. This document also describes resource management procedures at the PDSN and the HA that are used following an inter PDSN handoff or under other conditions that require release of resources. Furthermore, a procedure for provisioning the RAN with resource management parameters such as RN packet data inactivity timers is specified in this document.

	Document No.	Version	Status	Issued date	Location
CCSA	CCSA-TSD-MC-X.S0011-003-C	2.0	Approved	-- 01-2006	http://www.ccsa.org.cn/english/tc/files.php?docpath=/ITU-T/Q.1742/Q.1742
TTA	TTAT.3G-X.S0011-003-C V2.0	2.0	Approved	19-04-2006	http://www.tta.or.kr/standardDB/stnfile/TAT.3G-X.S0011-003-C v2.0.zip
TTC	TS-3GB-X.S0011-003-Cv2.0	2.0	TTC Published	26-08-2006	http://www.ttc.or.jp/imt2000/ts/tsxs0011-003-cv20.pdf

10.5.8.10 X.S0011-003-C Version 3.0 cdma2000 Wireless IP Network Standard: Packet Data Mobility and Resource Management (-- October 2006)

This document describes the mechanisms at the PDSN resulting from handoff of an MS from one BS/PCF to another BS/PCF, and which may result in changing the serving PDSN for the MS. This document describes an optional fast handoff capability, which is a low latency, low data loss handoff mechanism between PDSNs. Fast handoff mechanism delays re-negotiation of PPP until the MS becomes dormant at the target PDSN. This document also describes resource management procedures at the PDSN and the HA that are used following an inter PDSN handoff or under other conditions that require release of resources. Furthermore, a procedure for provisioning the RAN with resource management parameters such as RN packet data inactivity timers is specified in this document.

	Document No.	Version	Status	Issued date	Location
CCSA	CCSA-X.S0011-003-C v3.0	3.0	Approved	31-01-2007	http://www.ccsa.org.cn/english/tc/files.php?docpath=/ITU-T/Q.1742
TTA	TTAT.3G-X.S0011-003-C V3.0	3.0	Approved	15-02-2007	http://www.tta.or.kr/standardDB/stnfile/TTAT.3G-X.S0011-003-C v3.0.zip
TTC	TS-3GB-X.S0011-003-Cv3.0	3.0	TTC Published	23-02-2007	http://www.ttc.or.jp/imt2000/ts/tsxs0011-003-cv30.pdf

10.5.8.11 X.S0011-003-D Version 1.0 cdma2000 Wireless IP Network Standard: Data Mobility and Resource Management (-- February 2006)

This document describes the mechanisms at the PDSN resulting from handoff of an MS from one BS/PCF to another BS/PCF, and which may result in changing the serving PDSN for the MS. This document describes an optional fast handoff capability, which is a low latency, low data loss handoff mechanism between PDSNs. Fast handoff mechanism delays re-negotiation of PPP until the MS becomes dormant at the target PDSN. This document also describes resource management procedures at the PDSN and the HA that are used following an inter PDSN handoff or under other conditions that require release of resources. Furthermore, a procedure for provisioning the RAN with resource management parameters such as RN packet data inactivity timers is specified in this document.

	Document No.	Version	Status	Issued date	Location
CCSA	CCSA-X.S0011-003-D v1.0	1.0	Approved	31-01-2007	http://www.ccsa.org.cn/english/tc/files.php?docpath=/ITU-T/Q.1742
TTA	TTAT.3G-X.S0011-003-D V1.0	1.0	Approved	15-02-2007	http://www.tta.or.kr/standardDB/stnfile/TTAT.3G-X.S0011-003-D v1.0.zip
TTC	TS-3GB-X.S0011-003-Dv1.0	1.0	TTC Published	02-06-2006	http://www.ttc.or.jp/imt2000/ts/tsxs0011-003-dv10.pdf

10.5.8.12 X.S0011-004-C Version 1.0.0 cdma2000 Wireless IP Network Standard: Quality of Service and Header Reduction (-- August 2003)

This document describes flow mapping/treatment mechanisms and protocol used when more than one service instance is established for the MS. It also describes two optional header reduction techniques that are specific to service instances of SO type 60 and 61, that may be established by the MS for applications that require a synchronous flow of 20-ms frames, such as VoIP application.

	Document No.	Version	Status	Issued date	Location
CCSA	CCSA-TSD-MC-X.S0011-004-C V1.0.0	1	Approved	-- 08-2003	http://www.ccsa.org.cn/english/tc/files.php?docpath=/ITU-T/Q.1742
TIA	TIA-835-C		Published	-- 08-2003	http://www.tiaonline.org/standards/catalog/search.cfm
TTA	TTAT.3G-X.S0011-004-C V1.0.0	1.0.0	Approved	15-11-2004	http://www.tta.or.kr/standardDB/stnfile/TTAT.3G-X.S0011-004-C v1.0.0.zip
TTC	TS-3GB-X.S0011-004-Cv1.0.0	1.0.0	TTC published	28-11-2003	http://www.ttc.or.jp/imt2000/ts/tsxs0011-004-cv100.pdf

10.5.8.13 X.S0011-004-C Version 2.0 cdma2000 Wireless IP Network Standard: Quality of Service and Header Reduction (-- July 2005)

This document describes flow mapping/treatment mechanisms and protocol used when more than one service instance is established for the MS. It also describes two optional header reduction techniques that are specific to service instances of SO type 60 and 61, that may be established by the MS for applications that require a synchronous flow of 20-ms frames, such as VoIP application.

	Document No.	Version	Status	Issued date	Location
CCSA	CCSA-TSD-MC-X.S0011-004-C	2.0	Approved	-- 01-2006	http://www.ccsa.org.cn/english/tc/files.php?docpath=/ITU-T/Q.1742/Q.1742
TTA	TTAT.3G-X.S0011-004-C V2.0	2.0	Approved	19-04-2006	http://www.tta.or.kr/standardDB/stnfile/TTAT.3G-X.S0011-004-C v2.0.zip
TTC	TS-3GB-X.S0011-004-Cv2.0	2.0	TTC Published	26-08-2006	http://www.ttc.or.jp/imt2000/ts/tsxs0011-004-cv20.pdf

10.5.8.14 X.S0011-004-C Version 3.0 cdma2000 Wireless IP Network Standard: Quality of Service and Header Reduction (-- October 2006)

This document describes flow mapping/treatment mechanisms and protocol used when more than one service instance is established for the MS. It also describes two optional header reduction techniques that are specific to service instances of SO type 60 and 61, that may be established by the MS for applications that require a synchronous flow of 20-ms frames, such as VoIP application.

	Document No.	Version	Status	Issued date	Location
CCSA	CCSA-X.S0011-004-C v3.0	3.0	Approved	31-01-2007	http://www.ccsa.org.cn/english/tc/files.php?docpath=/ITU-T/Q.1742
TTA	TTAT.3G-X.S0011-004-C V3.0	3.0	Approved	15-02-2007	http://www.tta.or.kr/standardDB/stnfile/TTAT.3G-X.S0011-004-C v3.0.zip
TTC	TS-3GB-X.S0011-004-Cv3.0	3.0	TTC Published	23-02-2007	http://www.ttc.or.jp/imt2000/ts/tsxs0011-004-cv30.pdf

10.5.8.15 X.S0011-004-D Version 1.0 cdma2000 Wireless IP Network Standard: Quality of Service and Header Reduction (-- February 2006)

This document describes flow mapping/treatment mechanisms and protocols used when more than one service connection is established between the MS and the PDSN. Furthermore, a signalling mechanism between the MS, the RAN and the PDSN is presented in this document to support QoS on a per application flow basis. It also describes two optional header reduction techniques that are specific to service instances of SO type 60 and 61, which may be established by the MS for applications that require a synchronous flow of 20-ms frames, such as VoIP application. This document also specifies the requirement and procedures for MS and PDSN to support SO type 67.

	Document No.	Version	Status	Issued date	Location
CCSA	CCSA-X.S0011-004-D v1.0	1.0	Approved	31-01-2007	http://www.ccsa.org.cn/english/tc/files.php?docpath=/ITU-T/Q.1742
TTA	TTAT.3G-X.S0011-004-D V1.0	1.0	Approved	15-02-2007	http://www.tta.or.kr/standardDB/stnfile/TAT.3G-X.S0011-004-D v1.0.zip
TTC	TS-3GB-X.S0011-004-Dv1.0	1.0	TTC Published	02-06-2006	http://www.ttc.or.jp/imt2000/ts/tsxs0011-004-dv10.pdf

10.5.8.16 X.S0011-005-C Version 1.0.0 cdma2000 Wireless IP Network Standard: Accounting Services and 3GPP2 RADIUS VSAs (-- August 2003)

This document describes the off-line accounting procedures and the usage data records. It describes all the 3GPP2 VSAs used to support the capabilities described in this series of specifications X.S0011-001-C to X.S0011-006-C.

	Document No.	Version	Status	Issued date	Location
CCSA	CCSA-TSD-MC-X.S0011-005-C v1.0.0	1	Approved	-- 08-2003	http://www.ccsa.org.cn/english/tc/files.php?docpath=/ITU-T/Q.1742
TIA	TIA-835-C		Published	-- 08-2003	http://www.tiaonline.org/standards/catalog/search.cfm
TTA	TTAT.3G-X.S0011-005-C V1.0.0	1.0.0	Approved	15-11-2004	http://www.tta.or.kr/standardDB/stnfile/TAT.3G-X.S0011-005-C v1.0.0.zip
TTC	TS-3GB-X.S0011-005-Cv1.0.0	1.0.0	TTC Published	28-11-2003	http://www.ttc.or.jp/imt2000/ts/tsxs0011-005-cv100.pdf

10.5.8.17 X.S0011-005-C Version 2.0 cdma2000 Wireless IP Network Standard: Accounting Services and 3GPP2 RADIUS VSAs (-- July 2005)

This document describes the off-line accounting procedures and the usage data records. It describes all the 3GPP2 VSAs used to support the capabilities described in this series of specifications X.S0011-001-C to X.S0011-006-C.

	Document No.	Version	Status	Issued date	Location
CCSA	CCSA-TSD-MC-X.S0011-005-C	2.0	Approved	-- 01-2006	http://www.ccsa.org.cn/english/tc/files.php?docpath=/ITU-T/Q.1742/Q.1742
TTA	TTAT.3G-X.S0011-005-C V2.0	2.0	Approved	19-04-2006	http://www.tta.or.kr/standardDB/stnfile/TAT.3G-X.S0011-005-C v2.0.zip
TTC	TS-3GB-X.S0011-005-Cv2.0	2.0	TTC Published	26-08-2006	http://www.ttc.or.jp/imt2000/ts/tsxs0011-005-cv20.pdf

10.5.8.18 X.S0011-005-C Version 3.0 cdma2000 Wireless IP Network Standard: Accounting Services and 3GPP2 RADIUS VSAs (-- October 2006)

This document describes the off-line accounting procedures and the usage data records. It describes all the 3GPP2 VSAs used to support the capabilities described in this series of specifications X.S0011-001-C to X.S0011-006-C.

	Document No.	Version	Status	Issued date	Location
CCSA	CCSA-X.S0011-005-C v3.0	3.0	Approved	31-01-2007	http://www.ccsa.org.cn/english/tc/files.php?docpath=/ITU-T/Q.1742
TTA	TTAT.3G-X.S0011-005-C V3.0	3.0	Approved	15-02-2007	http://www.tta.or.kr/standardDB/stnfile/TAT.3G-X.S0011-005-C v3.0.zip
TTC	TS-3GB-X.S0011-005-Cv3.0	3.0	TTC Published	23-02-2007	http://www.ttc.or.jp/imt2000/ts/tsxs0011-005-cv30.pdf

10.5.8.19 X.S0011-005-D Version 1.0 cdma2000 Wireless IP Network Standard: Accounting Services and 3GPP2 RADIUS VSAs (-- February 2006)

This document describes the off-line accounting procedures and the usage data records. It describes all the 3GPP2 VSAs used to support the described capabilities.

	Document No.	Version	Status	Issued date	Location
CCSA	CCSA-X.S0011-005-D v1.0	1.0	Approved	31-01-2007	http://www.ccsa.org.cn/english/tc/files.php?docpath=/ITU-T/Q.1742
TTA	TTAT.3G-X.S0011-005-D V1.0	1.0	Approved	15-02-2007	http://www.tta.or.kr/standardDB/stnfile/TAT.3G-X.S0011-005-D v1.0.zip
TTC	TS-3GB-X.S0011-005-Dv1.0	1.0	TTC Published	02-06-2006	http://www.ttc.or.jp/imt2000/ts/tsxs0011-005-dv10.pdf

10.5.8.20 X.S0011-006-C Version 1.0.0 cdma2000 Wireless IP Network Standard: PrePaid Packet Data Service (-- August 2003)

Support for prepaid packet data services is optional in this specification. The prepaid packet data service allows a user to purchase packet data service in advance based on volume or duration. In order to support prepaid packet data service the PDSN and/or the HA shall support the prepaid client (PPC) function and the prepaid server (PPS) function may be co-located with the home RADIUS server.

	Document No.	Version	Status	Issued date	Location
CCSA	CCSA-TSD-MC-X.S0011-006-C V1.0.0	1	Approved	-- 08-2003	http://www.ccsa.org.cn/english/tc/files.php?docpath=/ITU-T/Q.1742
TIA	TIA-835-C		Published	-- 08-2003	http://www.tiaonline.org/standards/catalog/search.cfm
TTA	TTAT.3G-X.S0011-006-C V1.0.0	1.0.0	Approved	15-11-2004	http://www.tta.or.kr/standardDB/stnfile/TAT.3G-X.S0011-006-C v1.0.0.zip
TTC	TS-3GB-X.S0011-006-Cv1.0.0	1.0.0	TTC Published	28-11-2003	http://www.ttc.or.jp/imt2000/ts/tsxs0011-006-cv100.pdf

10.5.8.21 X.S0011-006-C Version 2.0 cdma2000 Wireless IP Network Standard: PrePaid Packet Data Services (-- July 2005)

Support for prepaid packet data services is optional in this specification. The prepaid packet data service allows a user to purchase packet data service in advance based on volume or duration. In order to support prepaid packet data service the PDSN and/or the HA shall support the prepaid client (PPC) function and the prepaid server (PPS) function may be co-located with the home RADIUS server. In this revision of the specification, the prepaid packet data service supports a set of capabilities as described in section 3 of the specification. Additional capabilities may be supported in future revisions of this specification.

	Document No.	Version	Status	Issued date	Location
CCSA	CCSA-TSD-MC-X.S0011-006-C	2.0	Approved	-- 01-2006	http://www.ccsa.org.cn/english/tc/files.php?docpath=/ITU-T/Q.1742/Q.1742
TTA	TTAT.3G-X.S0011-006-C V2.0	2.0	Approved	19-04-2006	http://www.tta.or.kr/standardDB/stnfile/TAT.3G-X.S0011-006-C v2.0.zip
TTC	TS-3GB-X.S0011-006-Cv2.0	2.0	TTC Published	26-08-2006	http://www.ttc.or.jp/imt2000/ts/tsxs0011-006-cv20.pdf

10.5.8.22 X.S0011-006-C Version 3.0 cdma2000 Wireless IP Network Standard: PrePaid Packet Data Services (-- October 2006)

Support for prepaid packet data services is optional in this specification. The prepaid packet data service allows a user to purchase packet data service in advance based on volume or duration. In order to support prepaid packet data service the PDSN and/or the HA shall support the prepaid client (PPC) function and the prepaid server (PPS) function may be co-located with the home RADIUS server. In this revision of the specification, the prepaid packet data service supports a set of capabilities as described in section 1. Additional capabilities may be supported in future revisions of this specification.

	Document No.	Version	Status	Issued date	Location
CCSA	CCSA-X.S0011-006-C v3.0	3.0	Approved	31-01-2007	http://www.ccsa.org.cn/english/tc/files.php?docpath=/ITU-T/Q.1742
TTA	TTAT.3G-X.S0011-006-C V3.0	3.0	Approved	15-02-2007	http://www.tta.or.kr/standardDB/stnfile/TAT.3G-X.S0011-006-C v3.0.zip
TTC	TS-3GB-X.S0011-006-Cv3.0	3.0	TTC Published	23-02-3007	http://www.ttc.or.jp/imt2000/ts/tsxs0011-006-cv30.pdf

10.5.8.23 X.S0011-006-D Version 1.0 cdma2000 Wireless IP Network Standard: PrePaid Packet Data Services (-- February 2006)

Support for prepaid packet data services is optional in this specification. The prepaid packet data service allows a user to purchase packet data service in advance based on volume or duration. In order to support prepaid packet data service the PDSN and/or the HA shall support the prepaid client (PPC) function and the prepaid server (PPS) function may be co-located with the home RADIUS server. In this revision of the specification, the PrePaid packet data service supports a set of capabilities as described in section 3. Additional capabilities may be supported in future revisions of this specification.

	Document No.	Version	Status	Issued date	Location
CCSA	CCSA-X.S0011-006-D v1.0	1.0	Approved	31-01-2007	http://www.ccsa.org.cn/english/tc/files.php?docpath=/ITU-T/Q.1742
TTA	TTAT.3G-X.S0011-006-D V1.0	1.0	Approved	15-02-2007	http://www.tta.or.kr/standardDB/stnfile/TAT.3G-X.S0011-006-D v1.0.zip
TTC	TS-3GB-X.S0011-006-Dv1.0	1.0	TTC Published	02-06-2006	http://www.ttc.or.jp/imt2000/ts/tsxs0011-006-dv10.pdf

10.5.9 X.S0012-0 Version 2.0 Legacy MS Domain Step 1 (-- March 2004)

This recommendation supports the 3GPP2 all-IP step 1 evolution path by providing stage 1, 2 and 3 for the architecture identified. The legacy MS domain provides support for existing MSs in an IP core network environment. The legacy MS domain supports the features and capabilities provided in a legacy network in a manner transparent to the user. New features and capabilities supported by the IP core network may be made available to subscribers where they are supported by MS capabilities.

	Document No.	Version	Status	Issued date	Location
CCSA	CCSA-TSD-MC-X.S0012-0 v2.0	1	Approved	-- 03-2004	http://www.ccsa.org.cn/english/tc/files.php?docpath=/ITU-T/Q.1742
TIA	TIA-872-A		Published	-- 05-2004	http://www.tiaonline.org/standards/catalog/search.cfm
TTA	TTAT.3G-X.S0012-0 V2.0	2.0	Approved	15-11-2004	http://www.tta.or.kr/standardDB/stnfile/TTAT.3G-X.S0012-0 v2.0.zip
TTC	TS-3GB-X.S0012-0v2.0	2.0	TTC Published	28-05-2004	http://www.ttc.or.jp/imt2000/ts/tsxs0012-0v20.pdf

10.5.10 X.S0013-000-0 Version 1.0 All-IP Core Network Multimedia Domain Overview (-- December 2003)

This document contains the introduction of the stage 1, stage 2, and stage 3 recommendations for the 3GPP2 all-IP multimedia domain. It includes an overview of the system elements and interfaces, and lists the series of documents that provide the complete specifications for the core network portions of the MMD. Not all MMD entities and interfaces may be covered by this version of this series of specifications. The specific entities and interfaces covered by a particular version are identified in each of the individual specifications.

	Document No.	Version	Status	Issued date	Location
CCSA	CCSA-TSD-MC-X.S0013-000-0 v1.0	1	Approved	-- 12-2003	http://www.ccsa.org.cn/english/tc/files.php?docpath=/ITU-T/Q.1742
TIA	TIA-873.000		Published	-- 12-2003	http://www.tiaonline.org/standards/catalog/search.cfm
TTA	TTAT.3G-X.S0013-000-0 V1.0	1.0	Approved	15-11-2004	http://www.tta.or.kr/standardDB/stnfile/TTAT.3G-X.S0013-000-0 v1.0.zip
TTC	TS-3GB-X.S0013-000-0v1.0	1.0	TTC Published	28-05-2004	http://www.ttc.or.jp/imt2000/ts/tsxs0013-000-0v10.pdf

10.5.10.1 X.S0013-000-0 Version 2.0 All-IP Core Network Multimedia Domain Overview (-- July 2005)

The multimedia domain (MMD) is a CDMA-based wireless network providing third generation capabilities and based on IP protocols, elements and principles. This document provides an introduction to the core network elements and interfaces that make up a portion of the MMD. This document also introduces the series of documents that provide the complete specification of the core network interfaces and protocols that provide this part of the MMD capabilities.

	Document No.	Version	Status	Issued date	Location
CCSA	CCSA-TSD-MC-X.S0013-000-0	2.0	Approved	-- 01-2006	http://www.ccsa.org.cn/english/tc/files.php?docpath=/ITU-T/Q.1742/Q.1742
TTA	TTAT.3G-X.S0013-000-0 V2.0	2.0	Approved	19-04-2006	http://www.tta.or.kr/standardDB/stnfile/TTAT.3G-X.S0013-000-0 v2.0.zip
TTC	TS-3GB-X.S0013-000-0v2.0	2.0	TTC Published	25-11-2005	http://www.ttc.or.jp/imt2000/ts/tsxs0013-000-0v20.pdf

10.5.10.2 X.S0013-000-A Version 1.0 All-IP Core Network Multimedia Domain Overview (-- November 2005)

The multimedia domain (MMD) is a collection of core network entities providing third generation capabilities and based on IP protocols, elements and principles. This document provides an introduction to the core network elements and interfaces that make up a portion of the MMD. This document also introduces the series of documents that provide the complete specification of the core network interfaces and protocols that provide this part of the MMD capabilities.

	Document No.	Version	Status	Issued date	Location
CCSA	CCSA-TSD-MC-X.S0013-000-A	1.0	Approved	-- 01-2006	http://www.ccsa.org.cn/english/tc/files.php?docpath=/ITU-T/Q.1742/Q.1742_
TTA	TTAT.3G-X.S0013-000-A V1.0	1.0	Approved	19-04-2006	http://www.tta.or.kr/standardDB/stnfile/TAT.3G-X.S0013-000-A v1.0.zip

10.5.10.3 X.S0013-002-0 Version 1.0 All-IP Core Network Multimedia Domain IP Multimedia Subsystem – Stage 2 (-- December 2003)

This document defines stage 2 service description for the IP multimedia core network subsystem (IMS), which includes the elements necessary to support IP multimedia (IM) services in PLMNs and perhaps other networks. This document identifies the mechanisms to enable support for IP multimedia applications.

	Document No.	Version	Status	Issued date	Location
CCSA	CCSA-TSD-MC-X.S0013-002-0 v1.0	1	Approved	-- 12-2003	http://www.ccsa.org.cn/english/tc/files.php?docpath=/ITU-T/Q.1742_
TIA	TIA-873.002		Published	-- 12-2003	http://www.tiaonline.org/standards/catalog/search.cfm
TTA	TTAT.3G-X.S0013-002-0 V1.0	1.0	Approved	15-11-2004	http://www.tta.or.kr/standardDB/stnfile/TAT.3G-X.S0013-002-0 v1.0.zip
TTC	TS-3GB-X.S0013-002-0v1.0	1.0	TTC Published	28-05-2004	http://www.ttc.or.jp/imt2000/ts/tsxs0013-002-0v10.pdf

10.5.10.4 X.S0013-002-A Version 1.0 All-IP Core Network Multimedia Domain IP Multimedia Subsystem – Stage 2 (-- November 2005)

This document defines stage 2 service description for the IP multimedia core network subsystem (IMS), which includes the elements necessary to support IP multimedia (IM) services. ITU-T Rec. I.130 describes a three-stage method for characterization of telecommunication services, and ITU-T Rec. Q.65 defines stage 2 of the method. This document identifies the mechanisms to enable support for IP multimedia applications. In order to align IP multimedia applications wherever possible with non-IMS IP applications, the general approach is to adopt non-IMS specific IP-based solutions.

	Document No.	Version	Status	Issued date	Location
CCSA	CCSA-TSD-MC-X.S0013-002-A	1.0	Approved	-- 01-2006	http://www.ccsa.org.cn/english/tc/files.php?docpath=/ITU-T/Q.1742/Q.1742_
TTA	TTAT.3G-X.S0013-002-A V1.0	1.0	Approved	19-04-2006	http://www.tta.or.kr/standardDB/stnfile/TAT.3G-X.S0013-002-A v1.0.zip

10.5.10.5 X.S0013-003-0 Version 1.0 All-IP Core Network Multimedia Domain IP Multimedia (IMS) Session Handling; IP Multimedia (IM) Call Model; Stage 2 (-- December 2003)

This document specifies the IP multimedia (IM) call model for handling of an IP multimedia session origination and termination for an IP multimedia subscriber.

	Document No.	Version	Status	Issued date	Location
CCSA	CCSA-TSD-MC-X.S0013-003-0 v1.0	1	Approved	-- 12-2003	http://www.ccsa.org.cn/english/tc/files.php?docpath=/ITU-T/Q.1742
TIA	TIA-873.003		Published	-- 12-2003	http://www.tiaonline.org/standards/catalog/search.cfm
TTA	TTAT.3G-X.S0013-003-0 V1.0	1.0	Approved	15-11-2004	http://www.tta.or.kr/standardDB/stnfile/TTAT.3G-X.S0013-003-0 v1.0.zip
TTC	TS-3GB-X.S0013-003-0v1.0	1.0	TTC Published	28-05-2004	http://www.ttc.or.jp/imt2000/ts/tsxs0013-003-0v10.pdf

10.5.10.6 X.S0013-003-0 Version 2.0 All-IP Core Network Multimedia Domain IP Multimedia (IMS) Session Handling; IP Multimedia (IM) Call Model; Stage 2 (-- July 2005)

This document specifies the IP multimedia (IM) call model for handling of an IP multimedia session origination and termination for an IP multimedia subscriber. This document includes interactions between an application server and IP multimedia sessions. The IP Multimedia (IM) Subsystem stage 2 and stage 3 for the IP multimedia call control based on SIP and SDP are specified in other documents.

	Document No.	Version	Status	Issued date	Location
CCSA	CCSA-TSD-MC-X.S0013-003-0	2.0	Approved	-- 01-2006	http://www.ccsa.org.cn/english/tc/files.php?docpath=/ITU-T/Q.1742/Q.1742
TTA	TTAT.3G-X.S0013-003-0 V2.0	2.0	Approved	19-04-2006	http://www.tta.or.kr/standardDB/stnfile/TTAT.3G-X.S0013-003-0 v2.0.zip
TTC	TS-3GB-X.S0013-003-0v2.0	2.0	TTC Published	25-11-2005	http://www.ttc.or.jp/imt2000/ts/tsxs0013-003-0v20.pdf

10.5.10.7 X.S0013-003-A Version 1.0 All-IP Core Network Multimedia Domain IP Multimedia (IMS) Session Handling; IP Multimedia (IM) Call Model; Stage 2 (-- November 2005)

This document specifies the IP multimedia (IM) call model for handling of an IP multimedia session origination and termination for an IP multimedia subscriber. This document includes interactions between an application server and IP multimedia sessions. The IP multimedia (IM) subsystem stage 2 and stage 3 for the IP multimedia call control based on SIP and SDP are specified in other documents.

	Document No.	Version	Status	Issued date	Location
CCSA	CCSA-TSD-MC-X.S0013-003-A	1.0	Approved	-- 01-2006	http://www.ccsa.org.cn/english/tc/files.php?docpath=/ITU-T/Q.1742/Q.1742
TTA	TTAT.3G-X.S0013-003-A V1.0	1.0	Approved	19-04-2006	http://www.tta.or.kr/standardDB/stnfile/TTAT.3G-X.S0013-003-A v1.0.zip

10.5.10.8 X.S0013-004-0 Version 1.0 All-IP Core Network Multimedia Domain IP Multimedia Call Control Protocol Based on SIP and SDP Stage 3 (-- December 2003)

This document defines a call control protocol for use in the IP multimedia (IM) core network (CN) subsystem based on the session initiation protocol (SIP), and the associated session description protocol (SDP).

	Document No.	Version	Status	Issued date	Location
CCSA	CCSA-TSD-MC-X.S0013-004-0 v1.0	1	Approved	-- 12-2003	http://www.ccsa.org.cn/english/tc/files.php?docpath=/ITU-T/Q.1742
TIA	TIA-873.004		Published	-- 12-2003	http://www.tiaonline.org/standards/catalog/search.cfm
TTA	TTAT.3G-X.S0013-004-0 V1.0	1.0	Approved	15-11-2004	http://www.tta.or.kr/standardDB/stnfile/TTAT.3G-X.S0013-004-0 v1.0.zip
TTC	TS-3GB-X.S0013-004-0v1.0	1.0	TTC Published	28-05-2004	http://www.ttc.or.jp/imt2000/ts/tsxs0013-004-0v10.pdf

10.5.10.9 X.S0013-004-0 Version 2.0 All-IP Core Network Multimedia Domain IP Multimedia Call Control Protocol Based on SIP and SDP Stage 3 (-- July 2005)

This document defines a call control protocol for use in the IP multimedia (IM) core network (CN) subsystem based on the session initiation protocol (SIP), and the associated session description protocol (SDP).

	Document No.	Version	Status	Issued date	Location
CCSA	CCSA-TSD-MC-X.S0013-004-0	2.0	Approved	-- 01-2006	http://www.ccsa.org.cn/english/tc/files.php?docpath=/ITU-T/Q.1742/Q.1742
TTA	TTAT.3G-X.S0013-004-0 V2.0	2.0	Approved	19-04-2006	http://www.tta.or.kr/standardDB/stnfile/TTAT.3G-X.S0013-004-0 v2.0.zip
TTC	TS-3GB-X.S0013-004-0v2.0	2.0	TTC Published	25-11-2005	http://www.ttc.or.jp/imt2000/ts/tsxs0013-004-0v20.pdf

10.5.10.10 X.S0013-004-A Version 1.0 All-IP Core Network Multimedia Domain IP Multimedia Call Control Protocol Based on SIP and SDP Stage 3 (-- November 2005)

This document defines a call control protocol for use in the IP multimedia (IM) core network (CN) subsystem based on the session initiation protocol (SIP), and the associated session description protocol (SDP).

	Document No.	Version	Status	Issued date	Location
CCSA	CCSA-TSD-MC-X.S0013-004-A	1.0	Approved	-- 01-2006	http://www.ccsa.org.cn/english/tc/files.php?docpath=/ITU-T/Q.1742/Q.1742
TTA	TTAT.3G-X.S0013-004-A V1.0	1.0	Approved	19-04-2006	http://www.tta.or.kr/standardDB/stnfile/TTAT.3G-X.S0013-004-A v1.0.zip

10.5.10.11 X.S0013-005-0 Version 1.0 All-IP Core Network Multimedia Domain IP Multimedia Subsystem Cx interface Signaling flows and Message Contents (-- December 2003)

This specification specifies the interactions between the home subscriber server (HSS) and the call session control functions (CSCF), referred to as the Cx interface. This document addresses the signalling flows for the Cx interface.

	Document No.	Version	Status	Issued date	Location
CCSA	CCSA-TSD-MC-X.S0013-005-0 v1.0	1	Approved	-- 12-2003	http://www.ccsa.org.cn/english/tc/files.php?docpath=/ITU-T/Q.1742
TIA	TIA-873.005		Published	-- 12-2003	http://www.tiaonline.org/standards/catalog/search.cfm
TTA	TTAT.3G-X.S0013-005-0v1.0	1.0	Approved	15-11-2004	http://www.tta.or.kr/standardDB/stnfile/TTAT.3G-X.S0013-005-0v1.0.zip
TTC	TS-3GB-X.S0013-005-0v1.0	1.0	TTC Published	28-05-2004	http://www.ttc.or.jp/imt2000/ts/tsxs0013-005-0v10.pdf

10.5.10.12 X.S0013-005-0 Version 2.0 All-IP Core Network Multimedia Domain IP Multimedia Subsystem Cx interface Signaling flows and Message Contents (-- July 2005)

This specification specifies the interactions between the home subscriber server (HSS) and the call session control functions (CSCF), referred to as the Cx interface. This document addresses the signalling flows for the Cx interface.

	Document No.	Version	Status	Issued date	Location
CCSA	CCSA-TSD-MC-X.S0013-005-0	2.0	Approved	-- 01-2006	http://www.ccsa.org.cn/english/tc/files.php?docpath=/ITU-T/Q.1742/Q.1742
TTA	TTAT.3G-X.S0013-005-0 V2.0	2.0	Approved	19-04-2006	http://www.tta.or.kr/standardDB/stnfile/TTAT.3G-X.S0013-005-0 v2.0.zip
TTC	3GB-X.S0013-005-0v2.0	2.0	TTC Published	25-11-2005	http://www.ttc.or.jp/imt2000/ts/tsxs0013-005-0v20.pdf

10.5.10.13 X.S0013-005-A Version 1.0 All-IP Core Network Multimedia Domain IP Multimedia Subsystem Cx interface Signalling flows and Message Contents (-- November 2005)

This specification specifies the interactions between the home subscriber server (HSS) and the call session control functions (CSCF), referred to as the Cx interface. This document addresses the signalling flows for the Cx interface.

	Document No.	Version	Status	Issued date	Location
CCSA	CCSA-TSD-MC-X.S0013-005-A	1.0	Approved	-- 01-2006	http://www.ccsa.org.cn/english/tc/files.php?docpath=/ITU-T/Q.1742/Q.1742
TTA	TTAT.3G-X.S0013-005-A V1.0	1.0	Approved	19-04-2006	http://www.tta.or.kr/standardDB/stnfile/TTAT.3G-X.S0013-005-A v1.0.zip

10.5.10.14 X.S0013-006-0 Version 1.0 All-IP Core Network Multimedia Domain Cx Interface Based on the Diameter Protocol; Protocol Details (-- December 2003)

This document defines a transport protocol for use in the IP multimedia (IM) core network (CN) subsystem based on Diameter.

	Document No.	Version	Status	Issued date	Location
CCSA	CCSA-TSD-MC-X.S0013-006-0 v1.0	1	Approved	-- 12-2003	http://www.ccsa.org.cn/english/tc/files.php?docpath=/ITU-T/Q.1742
TIA	TIA-873.006		Published	-- 12-2003	http://www.tiaonline.org/standards/catalog/search.cfm
TTA	TTAT.3G-X.S0013-006-0 V1.0	1.0	Approved	15-11-2004	http://www.tta.or.kr/standardDB/stnfile/TTAT.3G-X.S0013-006-0 v1.0.zip
TTC	TS-3GB-X.S0013-006-0v1.0	1.0	TTC Published	28-05-2004	http://www.ttc.or.jp/imt2000/ts/tsxs0013-006-0v10.pdf

10.5.10.15 X.S0013-006-0 Version 2.0 All-IP Core Network Multimedia Domain Cx Interface Based on the Diameter Protocol; Protocol Details (-- July 2005)

This document defines a transport protocol for use in the IP multimedia (IM) core network (CN) subsystem based on Diameter.

	Document No.	Version	Status	Issued date	Location
CCSA	CCSA-TSD-MC-X.S0013-006-0	2.0	Approved	-- 01-2006	http://www.ccsa.org.cn/english/tc/files.php?docpath=/ITU-T/Q.1742/Q.1742
TTA	TTAT.3G-X.S0013-006-0 V2.0	2.0	Approved	19-04-2006	http://www.tta.or.kr/standardDB/stnfile/TTAT.3G-X.S0013-006-0 v2.0.zip
TTC	TS-3GB-X.S0013-006-0v2.0	2.0	TTC Published	25-11-2005	http://www.ttc.or.jp/imt2000/ts/tsxs0013-006-0v20.pdf

10.5.10.16 X.S0013-006-A Version 1.0 All-IP Core Network Multimedia Domain Cx Interface Based on the Diameter Protocol; Protocol Details (-- November 2005)

This document defines a transport protocol for use in the IP multimedia (IM) core network (CN) subsystem based on Diameter. This document is applicable to the Cx interface between the I-CSCF/S-CSCF and the HSS.

	Document No.	Version	Status	Issued date	Location
CCSA	CCSA-TSD-MC-X.S0013-006-A	1.0	Approved	-- 01-2006	http://www.ccsa.org.cn/english/tc/files.php?docpath=/ITU-T/Q.1742/Q.1742
TTA	TTAT.3G-X.S0013-006-A V1.0	1.0	Approved	19-04-2006	http://www.tta.or.kr/standardDB/stnfile/TTAT.3G-X.S0013-006-A v1.0.zip

10.5.10.17 X.S0013-007-0 Version 1.0 All-IP Core Network Multimedia Domain IP Multimedia Subsystem – Charging Architecture (-- December 2003)

This document describes the architecture for charging and billing for IMS services. For the purpose of this document, the charging data is considered to be generated and collected by charging functions in the network elements. The objectives of the present document are to describe principles of charging in an IMS network, to provide a description of the charging architecture, and to provide the descriptions of events and triggers for the generation of charging data.

	Document No.	Version	Status	Issued date	Location
CCSA	CCSA-TSD-MC-X.S0013-007-0 v1.0	1	Approved	-- 12-2003	http://www.ccsa.org.cn/english/tc/files.php?docpath=/ITU-T/Q.1742
TTA	TTAT.3G-X.S0013-007-0 V1.0	1.0	Approved	15-11-2004	http://www.tta.or.kr/standardDB/stnfile/TTAT.3G-X.S0013-007-0 v1.0.zip
TTC	TS-3GB-X.S0013-007-0v1.0	1.0	TTC Published	28-05-2004	http://www.ttc.or.jp/imt2000/ts/tsxs0013-007-0v10.pdf

10.5.10.18 X.S0013-007-A Version 1.0 All-IP Core Network Multimedia Domain IP Multimedia Subsystem – Charging Architecture (-- November 2005)

This document describes the architecture for charging and billing for IMS services. For the purpose of this document, the charging data is considered to be generated and collected by charging functions in the network elements. The objectives of the present document are to describe principles of charging in an IMS network, to provide a description of the charging architecture, and to provide the descriptions of events and triggers for the generation of charging data.

	Document No.	Version	Status	Issued date	Location
CCSA	CCSA-TSD-MC-X.S0013-007-A	1.0	Approved	-- 01-2006	http://www.ccsa.org.cn/english/tc/files.php?docpath=/ITU-T/Q.1742/Q.1742
TTA	TTAT.3G-X.S0013-007-A V1.0	1.0	Approved	19-04-2006	http://www.tta.or.kr/standardDB/stnfile/TTAT.3G-X.S0013-007-A v1.0.zip

10.5.10.19 X.S0013-008-0 Version 1.0 All-IP Core Network Multimedia Domain IP Multimedia Subsystem – Accounting Information Flows and Protocol (-- December 2003)

This document defines a transport protocol for use in the IP multimedia (IM) core network (CN) subsystem based on Diameter.

	Document No.	Version	Status	Issued date	Location
CCSA	CCSA-TSD-MC-X.S0013-008-0 v1.0	1	Approved	-- 12-2003	http://www.ccsa.org.cn/english/tc/files.php?docpath=/ITU-T/Q.1742
TIA	TIA-873.008		Published	-- 12-2003	http://www.tiaonline.org/standards/catalog/search.cfm
TTA	TTAT.3G-X.S0013-008-0 V1.0	1.0	Approved	15-11-2004	http://www.tta.or.kr/standardDB/stnfile/TTAT.3G-X.S0013-008-0 v1.0.zip
TTC	TS-3GB-X.S0013-008-0v1.0	1.0	TTC Published	28-05-2004	http://www.ttc.or.jp/imt2000/ts/tsxs0013-008-0v10.pdf

10.5.10.20 X.S0013-008-0 Version 2.0 All-IP Core Network Multimedia Domain IP Multimedia Subsystem – Accounting Information Flows and Protocol (-- July 2005)

This document covers offline charging for the IMS.

	Document No.	Version	Status	Issued date	Location
CCSA	CCSA-TSD-MC-X.S0013-008-0	2.0	Approved	-- 01-2006	http://www.ccsa.org.cn/english/tc/files.php?docpath=/ITU-T/Q.1742/Q.1742
TTA	TTAT.3G-X.S0013-008-0 V2.0	2.0	Approved	19-04-2006	http://www.tta.or.kr/standardDB/stnfile/TTAT.3G-X.S0013-008-0 v2.0.zip
TTC	TS-3GB-X.S0013-008-0v2.0	2.0	TTC Published	25-11-2005	http://www.ttc.or.jp/imt2000/ts/tsxs0013-008-0v20.pdf

10.5.10.21 X.S0013-008-A Version 1.0 All-IP Core Network Multimedia Domain Offline Accounting Information Flows and Protocols (-- November 2005)

This document covers offline charging for the IMS.

	Document No.	Version	Status	Issued date	Location
CCSA	CCSA-TSD-MC-X.S0013-008-A	1.0	Approved	-- 01-2006	http://www.ccsa.org.cn/english/tc/files.php?docpath=/ITU-T/Q.1742/Q.1742
TTA	TTAT.3G-X.S0013-008-A V1.0	1.0	Approved	19-04-2006	http://www.tta.or.kr/standardDB/stnfile/TAT.3G-X.S0013-008-A v1.0.zip

10.5.10.22 X.S0013-010-0 Version 1.0 All-IP Core Network Multimedia Domain IP Multimedia Subsystem Sh Interface; Signaling flows and message contents – Stage 2 (-- December 2003)

This document specifies the interactions between the home subscriber server (HSS) and the SIP application server (AS) and between the HSS and the OSA service capability server (SCS). This interface is referred to as the Sh reference point. This document addresses the signalling flows and message contents for the protocol at the Sh interface.

	Document No.	Version	Status	Issued date	Location
CCSA	CCSA-TSD-MC-X.S0013-010-0 v1.0	1	Approved	-- 12-2003	http://www.ccsa.org.cn/english/tc/files.php?docpath=/ITU-T/Q.1742
TIA	TIA-873.010		Published	-- 12-2003	http://www.tiaonline.org/standards/catalog/search.cfm
TTA	TTAT.3G-X.S0013-010-0 V1.0	1.0	Approved	15-11-2004	http://www.tta.or.kr/standardDB/stnfile/TAT.3G-X.S0013-010-0 v1.0.zip
TTC	TS-3GB-X.S0013-010-0v1.0	1.0	TTC Published	2-05-2004	http://www.ttc.or.jp/imt2000/ts/tsxs0013-010-0v10.pdf

10.5.10.23 X.S0013-010-0 Version 2.0 All-IP Core Network Multimedia Domain IP Multimedia Subsystem Sh Interface; Signaling flows and message contents – Stage 2 (--July 2005)

This document specifies the interactions between the home subscriber server (HSS) and the SIP application server (AS) and between the HSS and the OSA service capability server (SCS). This interface is referred to as the Sh reference point. This document addresses the signalling flows and message contents for the protocol at the Sh interface.

	Document No.	Version	Status	Issued date	Location
CCSA	CCSA-TSD-MC-X.S0013-010-0	2.0	Approved	-- 01-2006	http://www.ccsa.org.cn/english/tc/files.php?docpath=/ITU-T/Q.1742/Q.1742.5
TTA	TTAT.3G-X.S0013-010-0 V2.0	2.0	Approved	19-04-2006	http://www.tta.or.kr/standardDB/stnfile/TAT.3G-X.S0013-010-0 v2.0.zip
TTC	TS-3GB-X.S0013-010-0v2.0	2.0	TTC Published	25-11-2005	http://www.ttc.or.jp/imt2000/ts/tsxs0013-010-0v20.pdf

10.5.10.24 X.S0013-010-A Version 1.0 All-IP Core Network Multimedia Domain IP Multimedia Subsystem Sh Interface; Signaling flows and message contents – Stage 2 (-- November 2005)

This document specifies the interactions between the home subscriber server (HSS) and the SIP application server (AS) and between the HSS and the OSA service capability server (SCS). This interface is referred to as the Sh reference point. This document addresses the signalling flows and message contents for the protocol at the Sh interface.

	Document No.	Version	Status	Issued date	Location
CCSA	CCSA-TSD-MC-X.S0013-010-A	1.0	Approved	-- 01-2006	http://www.ccsa.org.cn/english/tc/files.php?docpath=/ITU-T/Q.1742/Q.1742.5
TTA	TTAT.3G-X.S0013-010-A V1.0	1.0	Approved	19-04-2006	http://www.tta.or.kr/standardDB/stnfile/TAT.3G-X.S0013-010-A v1.0.zip

10.5.10.25 X.S0013-011-0 Version 1.0 All-IP Core Network Multimedia Domain IP Multimedia Sh Interface based on Diameter Protocols – Protocol Details – Stage 3 (-- December 2003)

This document defines a transport for use in the IP multimedia (IM) core network (CN) subsystem based on Diameter. The present document is applicable to the Sh interface between an SIP AS and the AAA, and the Sh interface between an SCS and the AAA.

	Document No.	Version	Status	Issued date	Location
CCSA	CCSA-TSD-MC-X.S0013-011-0 v1.0	1	Approved	-- 12-2003	http://www.ccsa.org.cn/english/tc/files.php?docpath=/ITU-T/Q.1742
TIA	TIA-873.011		Published	-- 12-2003	http://www.tiaonline.org/standards/catalog/search.cfm
TTA	TTAT.3G-X.S0013-011-0 V1.0	1.0	Approved	15-11-2004	http://www.tta.or.kr/standardDB/stnfile/TAT.3G-X.S0013-011-0 v1.0.zip
TTC	TS-3GB-X.S0013-011-0v1.0	1.0	TTC Published	28-05-2004	http://www.ttc.or.jp/imt2000/ts/tsxs0013-011-0v10.pdf

10.5.10.26 X.S0013-011-0 Version 2.0 All-IP Core Network Multimedia Domain Sh Interface based on Diameter Protocols – Protocol Details – Stage 3 (-- July 2005)

This document defines a transport for use in the IP multimedia (IM) core network (CN) subsystem based on Diameter. The present document is applicable to the Sh interface between an SIP AS and the AAA, and the Sh interface between an SCS and the AAA.

	Document No.	Version	Status	Issued date	Location
CCSA	CCSA-TSD-MC-X.S0013-011-0	2.0	Approved	-- 01-2006	http://www.ccsa.org.cn/english/tc/files.php?docpath=/ITU-T/Q.1742/Q.1742.5
TTA	TTAT.3G-X.S0013-011-0 V2.0	2.0	Approved	19-04-2006	http://www.tta.or.kr/standardDB/stnfile/TAT.3G-X.S0013-011-0 v2.0.zip
TTC	TS-3GB-X.S0013-011-0v2.0	2.0	TTC Published	25-11-2005	http://www.ttc.or.jp/imt2000/ts/tsxs0013-011-0v20.pdf

10.5.10.27 X.S0013-011-A Version 1.0 All-IP Core Network Multimedia Domain Sh Interface based on Diameter Protocols Protocol Details – Stage 3 (-- November 2005)

This document defines a transport for use in the IP multimedia (IM) core network (CN) subsystem based on Diameter. The present document is applicable to the Sh interface between an SIP AS and the AAA, and the Sh interface between an SCS and the AAA.

	Document No.	Version	Status	Issued date	Location
CCSA	CCSA-TSD-MC-X.S0013-011-A	1.0	Approved	-- 01-2006	http://www.ccsa.org.cn/english/tc/files.php?docpath=/ITU-T/Q.1742/Q.1742.5
TTA	TTAT.3G-X.S0013-011-A V1.0	1.0	Approved	19-04-2006	http://www.tta.or.kr/standardDB/stnfile/TAT.3G-X.S0013-011-A v1.0.zip

10.5.11 X.S0014-E Version 1.0 Wireless Radio Telecommunication Intersystem Non-Signaling Data Communication DMH (Data Message Handler) (-- December 2004)

This document describes the messages and procedures required to perform call detail record data transmission between systems.

	Document No.	Version	Status	Issued date	Location
CCSA	CCSA-TSD-MC-X.S0014-E	1.0	Approved	-09-2005	http://www.ccsa.org.cn/english/tc/files.php?docpath=/ITU-T/Q.1742/Q.1742.5
TIA	TIA-124-E		Published	-- 05-2005	http://www.tiaonline.org/standards/catalog/search.cfm
TTA	TTAT.3G-X.S0014-E V1.0	1.0	Approved	09-12-2005	http://www.tta.or.kr/standardDB/stnfile/TTAT.3G-X.S0014-E v1.0.zip
TTC	TS-3GB-X.S0014-Ev1.0	1.0	TTC Published	02-06-2005	http://www.ttc.or.jp/imt2000/ts/tsxs0014-ev10.pdf

10.5.11.1 X.S0014-E Version 2.0 Wireless Radio Telecommunication Intersystem Non-Signaling Data Communication DMH (Data Message Handler) (-- August 2006)

This document describes the messages and procedures required to perform call detail record data transmission between systems.

	Document No.	Version	Status	Issued date	Location
CCSA	CCSA-X.S0014-E v2.0	2.0	Approved	31-01-2007	http://www.ccsa.org.cn/english/tc/files.php?docpath=/ITU-T/Q.1742
TTA	TTAT.3G-X.S0014-E V2.0	2.0	Approved	15-02-2007	http://www.tta.or.kr/standardDB/stnfile/TTAT.3G-X.S0014-E v2.0.zip
TTC	TS-3GB-X.S0014-Ev2.0	2.0	TTC Published	01-12-2006	http://www.ttc.or.jp/imt2000/ts/tsxs0014-ev20.pdf

10.5.12 X.S0017 Version 1.0.0 Open Service Access (OSA) Application Programming Interface (API) OSA API Revision: 0 (-- June 2003)

This document is intended to define the OSA API stage 3 interface definitions and it provides the complete OSA specifications for cdma2000-based systems. This document is an extension of OSA API, per latest 3GPP TS 29.198 series specifications capabilities to enable operation in cdma2000 systems environment as part of the TIA/EIA/IS-2000 family of standards. The information given here is to be used by developers in 3GPP2 cdma2000 network architecture to the 3GPP OSA specifications.

	Document No.	Version	Status	Issued date	Location
CCSA	CCSA-TSD-MC-X.S0017 v1.0.0	1	Approved	-- 06-2003	http://www.ccsa.org.cn/english/tc/files.php?docpath=/ITU-T/Q.1742
TIA	TIA-937		Published	-- 06-2003	http://www.tiaonline.org/standards/catalog/search.cfm
TTA	TTAT.3G-X.S0017 V1.0.0	1.0.0	Approved	15-11-2004	http://www.tta.or.kr/standardDB/stnfile/TTAT.3G-X.S0017 v1.0.0.zip
TTC	TS-3GB-X.S0017-0v1.0.0	1.0.0	TTC Published	28-11-2003	http://www.ttc.or.jp/imt2000/ts/tsxs0017-0v100.pdf

10.5.13 X.S0018 Version 1.0.0 Legacy Mobile Station Domain (LMSD) Step 1 Revision: 0 (May 2003)

This standard specifies the necessary interfaces to support the bearer traffic between media gateways in the initial step of the legacy mobile station domain (LMSD). The requirements for this work and the overall architecture model are defined in other documents.

This standard defines bearer support of G.711 PCM encoded voice over IP as defined in RFC 1890 at a minimum, for use between media gateways in a cdma2000 legacy mobile station domain. This standard utilizes existing IETF and 3GPP2 protocols when applicable to minimize the new work needed.

	Document No.	Version	Status	Issued date	Location
CCSA	CCSA-TSD-MC-X.S0018-0	1.0.0	Approved	09-2003	http://www.ccsa.org.cn/english/tc/files.php?docpath=/ITU-T/Q.1742/R3-2003-11
TIA	TIA-930		Published	-- 01-2003	http://www.tiaonline.org/standards/catalog/search.cfm
TTA	TTAT.3G-X.S0018_v1.0.0	1.0.0	Approved	30-10-2003	http://www.tta.or.kr/standardDB/stnfile/TTAT.3G-X.S0018_v1.0.0.zip

10.5.14 X.S0021-B Version 1.0 Roamer Database Verification (-- July 2004)

The purpose of this document is to describe the RDV network capability and to specify the operation of RDV so that wireless systems can use RDV.

	Document No.	Version	Status	Issued date	Location
CCSA	CCSA-TSD-MC-X.S0021-B	1.0	Approved	-09-2005	http://www.ccsa.org.cn/english/tc/files.php?docpath=/ITU-T/Q.1742/Q.1742.5
TIA	TIA-847-B		Published	-- 08-2004	http://www.tiaonline.org/standards/catalog/search.cfm
TTA	TTAT.3G-X.S0021-B v1.0	1.0	Approved	09-12-2005	http://www.tta.or.kr/standardDB/stnfile/TTAT.3G-X.S0021-B v1.0.zip
TTC	TS-3GB-X.S0021-Bv1.0	1.0	TTC Published	30-11-2004	http://www.ttc.or.jp/imt2000/ts/tsxs0021-bv10.pdf

10.5.15 X.S0023-B Version 1.0 Network Interworking Between GSM MAP and TIA-41 Map – cdma 2000 Support (-- July 2004)

The purpose of this standard is to define and describe the functions necessary for roaming between ANSI-41 MAP and GSM MAP-based networks in the support of roaming subscribers. This includes a capability to allow a subscriber to an ANSI-41-based network (e.g., a TDMA or CDMA native subscriber) with a mobile terminal supporting GPRS service to roam to a GPRS network in GSM foreign mode.

	Document No.	Version	Status	Issued date	Location
CCSA	CCSA-TSD-MC-X.S0023-B	1.0	Approved	-09-2005	http://www.ccsa.org.cn/english/tc/files.php?docpath=/ITU-T/Q.1742/Q.1742.5
TIA	J-STD-038-B		Published	-- 08-2004	http://www.tiaonline.org/standards/catalog/search.cfm
TTA	TTAT.3G-X.S0023-B v1.0	1.0	Approved	09-12-2005	http://www.tta.or.kr/standardDB/stnfile/TTAT.3G-X.S0023-B v1.0.zip
TTC	TS-3GB-X.S0023-Bv1.0	1.0	TTC Published	03-09-2004	http://www.ttc.or.jp/imt2000/ts/tsxs0023-bv10.pdf

10.5.16 X.S0025-0 Version 1.0 Legacy MS Domain Step 2 (-- February 2006)

The legacy MS domain (LMSD) provides support for existing MSs in a network that supports IP bearers. This specification provides support for transport of compressed speech (e.g., 13K, SMV, EVRC, etc.) over IP bearers. All bearer features in the legacy network are supported. Additionally, this specification provides support for placing bearer signal processing transcoders in the base station (BS) and/or in the media gateway (MGW). Network capabilities that support minimizing the number of transcoders in the bearer path are also supported.

	Document No.	Version	Status	Issued date	Location
CCSA	CCSA-X.S0025-0 v1.0	1.0	Approved	31-01-2007	http://www.ccsa.org.cn/english/tc/files.php?docpath=/ITU-T/Q.1742
TTA	TTAT.3G-X.S0025-0 v1.0	1.0	Approved	15-02-2007	http://www.tta.or.kr/standardDB/stnfile/TTAT.3G-X.S0025-0 v1.0.zip
TTC	TS-3GB-X.S0025-0v1.0	1.0	TTC Published	02-06-2006	http://www.ttc.or.jp/imt2000/ts/tsxs0025-0v10.pdf

10.5.17 X.S0027-000-0 Version 1.0 Presence Overview (-- September 2004)

This document describes network aspects of the presence service.

	Document No.	Version	Status	Issued date	Location
CCSA	CCSA-TSD-MC-X.S0027-000-0	1.0	Approved	-09-2005	http://www.ccsa.org.cn/english/tc/files.php?docpath=/ITU-T/Q.1742/Q.1742.5
TIA	TIA-1032.000		Published	-- 11-2004	http://www.tiaonline.org/standards/catalog/search.cfm
TTA	TTAT.3G-X.S0027-000-0 v1.0	1.0	Approved	09-12-2005	http://www.tta.or.kr/standardDB/stnfile/TTAT.3G-X.S0027-000-0 v1.0.zip
TTC	TS-3GB-X.S0027-000-0v1.0	1.0	TTC Published	30-11-2004	http://www.ttc.or.jp/imt2000/ts/tsxs0027-000-0v10.pdf

10.5.17.1 X.S0027-001-0 Version 1.0 Presence Service: Architecture and Functional Description (-- September 2004)

This document describes the stage 2 (architectural solution and functionalities) for the presence service, which includes the elements necessary to realize the stage 1 requirements.

	Document No.	Version	Status	Issued date	Location
CCSA	CCSA-TSD-MC-X.S0027-001-0	1.0	Approved	-09-2005	http://www.ccsa.org.cn/english/tc/files.php?docpath=/ITU-T/Q.1742/Q.1742.5
TIA	TIA-1032		Published	-- 11-2004	http://www.tiaonline.org/standards/catalog/search.cfm
TTA	TTAT.3G-X.S0027-001-0 v1.0	1.0	Approved	09-12-2005	http://www.tta.or.kr/standardDB/stnfile/TTAT.3G-X.S0027-001-0 v1.0.zip
TTC	TS-3GB-X.S0027-001-0v1.0	1.0	TTC Published	30-11-2004	http://www.ttc.or.jp/imt2000/ts/tsxs0027-001-0v10.pdf

10.5.18 X.S0030-0 Version 1.0 MAP Enhancements to Support Enhanced Message Waiting Notification (MWN) (-- September 2005)

This document provides automatic roaming information flows that illustrate enhanced message waiting count operation. This document also describes the signalling protocol and signalling procedure modifications needed for enhanced message waiting count operation.

	Document No.	Version	Status	Issued date	Location
CCSA	CCSA-TSD-MC-X.S0030-0	1	Approved	-- 01-2006	http://www.ccsa.org.cn/english/tc/files.php?docpath=/ITU-T/Q.1742/Q.1742.5
TTA	TTAT.3G-X.S0030-0 v1.0	1.0	Approved	19-04-2006	http://www.tta.or.kr/standardDB/stnfile/TTAT.3G-X.S0030-0 v1.0.zip
TTC	TS-3GB-X.S0030-0v1.0	1.0	TTC Published	25-11-2005	http://www.ttc.or.jp/imt2000/ts/tsxs0030-0v10.pdf

10.5.19 X.S0033-0 Version 1.0 OTA Support for MEID (-- October 2005)

This document presents a recommended plan for the implementation of over-the-air (OTA) support for the mobile equipment identity (MEID)

	Document No.	Version	Status	Issued date	Location
CCSA	CCSA-TSD-MC-X.S0033-0	1.0	Approved	-- 01-2006	http://www.ccsa.org.cn/english/tc/files.php?docpath=/ITU-T/Q.1742/Q.1742.5
TIA	TIA-1074		Published	-- 03-2006	http://www.tiaonline.org/standards/catalog/search.cfm
TTA	TTAT.3G-X.S0033-0 v1.0	1.0	Approved	19-04-2006	http://www.tta.or.kr/standardDB/stnfile/TTAT.3G-X.S0033-0 v1.0.zip
TTC	TS-3GB-X.S0033-0v1.0	1.0	TTC Published	25-11-2005	http://www.ttc.or.jp/imt2000/ts/tsxs0033-0v10.pdf

10.5.19.1 X.S0033-0 Version 2.0 OTA Support for MEID (-- February 2006)

This document presents a recommended plan for the implementation of over-the-air (OTA) support for the mobile equipment identity (MEID)

	Document No.	Version	Status	Issued date	Location
CCSA	CCSA-X.S0033-0 v2.0	2.0	Approved	31-01-2007	http://www.ccsa.org.cn/english/tc/files.php?docpath=/ITU-T/Q.1742
TTA	TTAT.3G-X.S0033-0 v2.0	2.0	Approved	15-02-2007	http://www.tta.or.kr/standardDB/stnfile/TTAT.3G-X.S0033-0 v2.0.zip
TTC	TS-3GB-X.S0033-0v2.0	2.0	TTC Published	02-06-2006	http://www.ttc.or.jp/imt2000/ts/tsxs0033-0v20.pdf

10.5.20 X.S0034-0 Version 1.0 cdma2000/GPRS Roaming (-- September 2004)

The scope of this document includes the roaming of a subscriber homed in a cdma2000 packet data system to a GPRS system and vice versa. The roaming between cdma2000 packet data systems is outside the scope of this document.

	Document No.	Version	Status	Issued date	Location
CCSA	CCSA-TSD-MC-X.S0034-0	1.0	Approved	-09-2005	http://www.ccsa.org.cn/english/tc/files.php?docpath=/ITU-T/Q.1742/Q.1742.5
TTA	TTAT.3G-X.S0034-0 v1.0	1.0	Approved	09-12-2005	http://www.tta.or.kr/standardDB/stnfile/TTAT.3G-X.S0034-0 v1.0.zip
TTC	TS-3GB-X.S0034-0v1.0	1.0	TTC Published	26-08-2005	http://www.ttc.or.jp/imt2000/ts/tsxs0034-0v10.pdf

10.5.21 X.S0037-0 Version 1.0 Tunneling Support in Simple IP (-- May 2006)

The scope of this specification includes tunnelling support for the simple IP packet data subscriber roaming across cdma2000 packet data systems that are administered by different service providers. In this specification, the tunnelling scheme is specified in the context of layer-two tunnelling. Other tunnelling schemes are not precluded.

	Document No.	Version	Status	Issued date	Location
CCSA	CCSA-X.S0037-0 v1.0	1.0	Approved	31-01-2007	http://www.ccsa.org.cn/english/tc/files.php?docpath=/ITU-T/Q.1742
TTA	TTAT.3G-X.S0037-0 v1.0	1.0	Approved	15-02-2007	http://www.tta.or.kr/standardDB/stnfile/TTAT.3G-X.S0037-0 v1.0.zip
TTC	TS-3GB-X.S0037-0v1.0	1.0	TTC Published	02-06-2006	http://www.ttc.or.jp/imt2000/ts/tsxs0037-0v10.pdf

10.5.22 X.R0039-0 Version 1.0 Packet Switched Voice (over IP) and Video Telephony Services End-to-End Design Technical Report (-- November 2005)

This document describes the end-to-end protocols and procedures for support of packet switched Video Telephony (PSVT) and Voice-Over-IP (VoIP) Services over cdma2000[®] networks. The document describes the end-to-end PSVT and VoIP services and architectures.

	Document No.	Version	Status	Issued date	Location
CCSA	CCSA-X.R0039-0 v1.0	1.0	Approved	31-01-2007	http://www.ccsa.org.cn/english/tc/files.php?docpath=/ITU-T/Q.1742
TTA	TTAT.3G-X.R0039-0 v1.0	1.0	Approved	15-02-2007	http://www.tta.or.kr/standardDB/stnfile/TTAT.3G-X.R0039-0 v1.0.zip
TTC	TS-3GB-X.R0039-0v1.0	1.0	TTC Published	02-06-2006	http://www.ttc.or.jp/imt2000/ts/tsxr0039-0v10.pdf

SERIES OF ITU-T RECOMMENDATIONS

Series A	Organization of the work of ITU-T
Series D	General tariff principles
Series E	Overall network operation, telephone service, service operation and human factors
Series F	Non-telephone telecommunication services
Series G	Transmission systems and media, digital systems and networks
Series H	Audiovisual and multimedia systems
Series I	Integrated services digital network
Series J	Cable networks and transmission of television, sound programme and other multimedia signals
Series K	Protection against interference
Series L	Construction, installation and protection of cables and other elements of outside plant
Series M	Telecommunication management, including TMN and network maintenance
Series N	Maintenance: international sound programme and television transmission circuits
Series O	Specifications of measuring equipment
Series P	Telephone transmission quality, telephone installations, local line networks
Series Q	Switching and signalling
Series R	Telegraph transmission
Series S	Telegraph services terminal equipment
Series T	Terminals for telematic services
Series U	Telegraph switching
Series V	Data communication over the telephone network
Series X	Data networks, open system communications and security
Series Y	Global information infrastructure, Internet protocol aspects and next-generation networks
Series Z	Languages and general software aspects for telecommunication systems