



INTERNATIONAL TELECOMMUNICATION UNION

ITU-T

TELECOMMUNICATION
STANDARDIZATION SECTOR
OF ITU

Q.86

(10/95)

**GENERAL RECOMMENDATIONS
ON TELEPHONE SWITCHING AND SIGNALLING
FUNCTIONS AND INFORMATION FLOWS
FOR SERVICES IN THE ISDN**

**STAGE 2 DESCRIPTION FOR CHARGING
SUPPLEMENTARY SERVICES**

**CLAUSE 7 – INTERNATIONAL
TELECOMMUNICATION
CHARGE CARD (ITCC)**

ITU-T Recommendation Q.86

(Previously “CCITT Recommendation”)

FOREWORD

The ITU-T (Telecommunication Standardization Sector) is a permanent organ of the International Telecommunication Union (ITU). The ITU-T is responsible for studying technical, operating and tariff questions and issuing Recommendations on them with a view to standardizing telecommunications on a worldwide basis.

The World Telecommunication Standardization Conference (WTSC), which meets every four years, establishes the topics for study by the ITU-T Study Groups which, in their turn, produce Recommendations on these topics.

The approval of Recommendations by the Members of the ITU-T is covered by the procedure laid down in WTSC Resolution No. 1 (Helsinki, March 1-12, 1993).

ITU-T Recommendation Q.86, clause 7 was revised by ITU-T Study Group 11 (1993-1996) and was approved under the WTSC Resolution No. 1 procedure on the 17th of October 1995.

NOTE

In this Recommendation, the expression "Administration" is used for conciseness to indicate both a telecommunication administration and a recognized operating agency.

© ITU 1996

All rights reserved. No part of this publication may be reproduced or utilized in any form or by any means, electronic or mechanical, including photocopying and microfilm, without permission in writing from the ITU.

CONTENTS

		<i>Page</i>
7	International Telecommunication Charge Card (ITEC).....	1
	7.1 Scope	1
	7.2 References.....	1
	7.3 Definitions	2
	7.4 Abbreviations.....	2
	7.5 Description of ITCC	3
	7.6 Functional model for ITCC.....	3
	7.6.1 Functional model description.....	3
	7.7 Information Flows for ITCC.....	6
	7.7.1 ITCC procedures	6
	7.7.2 Definition of individual information flows	9
	7.8 SDL diagrams for ITCC	11
	7.8.1 Card validation procedure.....	12
	7.8.2 Call Disposition procedure.....	14
	7.9 Functional Entity Actions	14
	7.10 Allocation of FEs to physical locations	19
	Appendix I – Access and identification procedure.....	21
	Appendix II – Validation Rejection and Retry procedure	23
	Appendix III – Maximum retries reached and service logic initiated release procedure	25
	Appendix IV – Outgoing call	25
	Appendix V – Calling party abandon	27
	Appendix VI – Calling and called party initiated disconnection.....	28
	Appendix VII – Follow-on recognition	29
	Appendix VIII – Network initiated disconnection	30

SUMMARY

This Recommendation provides the stage 2 service description of the International Telecommunication Charge Card supplementary service. This Recommendation describes the validation of the charge card in terms of the transfer of the necessary validation information to the card issuing administration across an international interface.

STAGE 2 DESCRIPTION FOR CHARGING SUPPLEMENTARY SERVICES

(revised 1995)

7 International Telecommunication Charge Card (ITEC)

7.1 Scope

This Recommendation provides a stage 2 description for the International Telecommunication Charge Card (ITCC) as defined in Recommendations E.113 and E.118. The ITCC service provides for the validation of the charge card and transmission of call documentation to the card issuing Administration across the international interface (SCF-SDF). Other interfaces associated with placing an international charge card call that are beyond the international validation (e.g. collecting information and user prompting performed by SRF) are national in nature and therefore beyond the scope of this Recommendation.

7.2 References

The following Recommendations and other references contain provisions which, through reference in this text, constitute provisions of this Recommendation. At the time of publication, the editions indicated were valid. All Recommendations and other references are subject to revision: all users of this Recommendation are therefore encouraged to investigate the possibility of applying the most recent edition of the Recommendations and other references listed below. A list of the currently valid ITU-T Recommendations is regularly published.

- ITU-T Recommendation E.109 (1995) – *International billed number screening procedures for collect and third-party calling.*
- ITU-T Recommendation E.113 (1993), *Validation procedures for the international telecommunications charge card service.*
- CCITT Recommendation E.116 (1992), *International telecommunication charge card service.*
- CCITT Recommendation E.118 (1992), *The international telecommunication charge card.*
- ITU-T Recommendation Q.1205 (1993), *Intelligent network physical plane architecture.*
- ITU-T Recommendation Q.1213 (1993), *Global functional plane for intelligent network CS-1.*
- ITU-T Recommendation Q.1214 (1993), *Distributed functional plane for intelligent network CS-1.*
- ITU-T Recommendation Q.1218 (1993), *Interface Recommendation for intelligent network CS-1.*
- ITU-T Recommendation Q.1219 (1994), *Intelligent network user's guide for capability set 1.*
- ITU-T Recommendation Q.71 (1993), *ISDN circuit mode switched bearer services.*
- CCITT Recommendation Q.65 (1988), *Stage 2 of the method for the characterization of services supported by an ISDN.*
- ITU-T Recommendation clause 1/Q.736 (1995), *International Telecommunication charge card (ITCC).*

7.3 Definitions

For the purposes of this Recommendation, the following definitions apply.

7.3.1 card acceptor (Subclause 3.2/E.116): The Recognized Operating Agency (ROA) that accepts the use of the card as payment for the provision of certain telecommunication services.

7.3.2 card acceptor SDF: It is the SDF (Service Data Functions) of the card acceptor where the service agreements are stored. It is designated SDF(ca).

7.3.3 card issuer: (Subclause 3.1/E.116) The Recognized Operating Agency (ROA) that issues the card. The card issuer is responsible for the collection of charges from the card holder and for making the appropriate payments for the service concerned to the card acceptor.

7.3.4 card issuer SDF: It is the SDF of the card issuer where the ITCC charge card user profile is stored. It is designated SDF(ci).

7.3.5 originating network: The network from which any user originates an ITCC service request.

7.3.6 personal identification number (Subclause 2.2.6/E.113): The Personal Identification Number (PIN) is used by the card issuer to identify the user and authorize the use of the card. It is obtained from the user or encoded on the card.

7.3.7 primary account number (Subclauses 2.2.3/E.113 and 2.1/E.118): The Primary Account Number (PAN) (19 visible characters – maximum) is the number assigned to a charge card. It is obtained from the card or the user when the user attempts to make a charge card call. The user identification number, which is a subpart of the Primary Account Number, can be used by the call originating ROA to identify the card-issuing ROA.

7.3.8 terminating network: It is the network of the called party.

7.4 Abbreviations

For the purposes of this Recommendation, the following abbreviations are used.

BCSM	Basic Call State Model (in Recommendation Q.1214)
CCAF	Call Control Agent Function
CCF	Call Control Function
CHG	Charge SIB
CLI	Calling Line Identity
CS-1	Capability Set 1
DP	Detection Point (in BCSM)
EDP	Event Detection Point (in BCSM)
EDP-N	Event Detection Point – Notification (in BCSM)
EDP-R	Event Detection Point – Report (in BCSM)
FE	Functional Entity
FEA	Functional Entity Action
IE	Information Element
IF	Information Flow
IN	Intelligent Network
IP	Intelligent Peripheral
ISDN	Integrated Services Digital Network
ITCC	International Telecommunication Charge Card
PSTN	Public Switched Telephone Network
SCF	Service Control Function
SDF	Service Data Function

SDF(ca)	Card Acceptor Service Data Function
SDF(ci)	Card Issuer Service Data Function
SIB	Service Independent Building Block
SRF	Specialized Resource Function
SSF	Service Switching Function

7.5 Description of ITCC

The International Telecommunication Charge Card service allows the holder of a telecommunication charge card to make use of a variety of telecommunication services provided by the card acceptor and have the charges billed to the customer's account by the card issuer (see Recommendations E.113, E.116 and E.118).

7.6 Functional model for ITCC

7.6.1 Functional model description

This subclause contains a description of the functional model of ITCC and it is depicted in Figure 1. The functional model merges the IN and non-IN models as defined in the reviewed Recommendation Q.65. It contains nine Functional Entities (FE1 to FE9) and seven relationship types (Rj, Rm, Rn, Rp, Rq, Rs and Rr). Functional Entities are represented by circles and the relationship between two communicating functional entities is identified by a line joining them. Modelling of entities and information flows which relate to the service management are not shown.

There are three networks involved in the validation procedure. They are originating, terminating and card issuing.

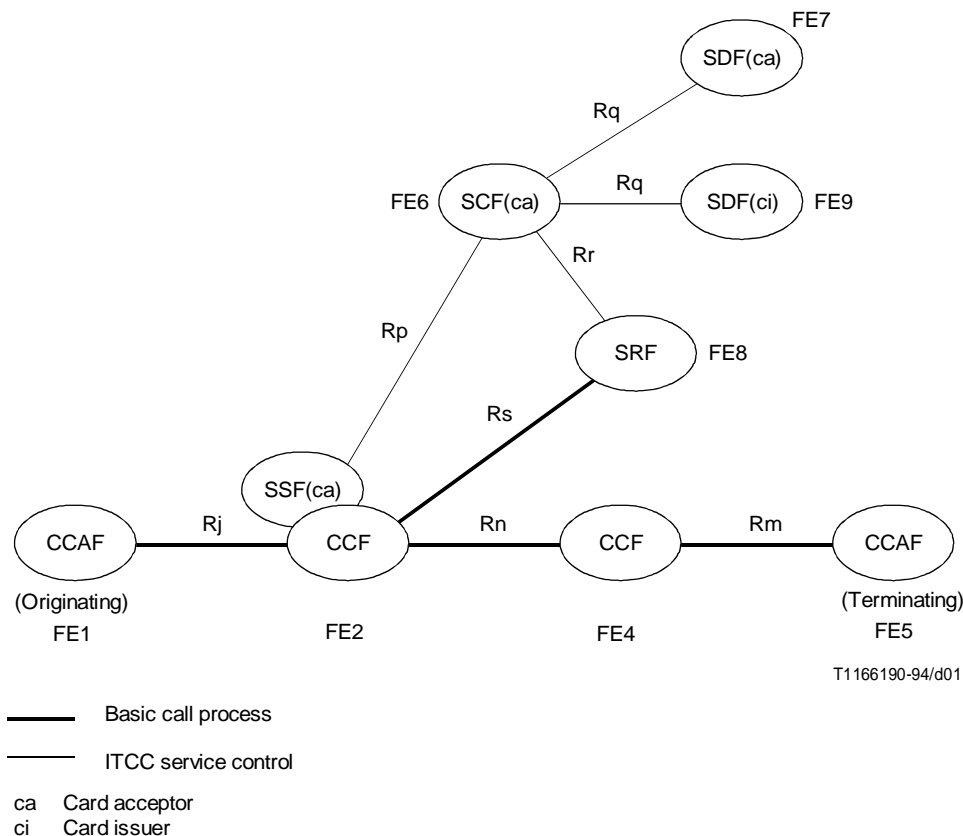

FIGURE 1/Q.86
Functional model for ITCC provision

In Figure 1 the Functional Entities (FEs) have the following meaning:

- FE1: Originating Call Control Agent Function (CCAF).
- FE2: Originating Call Control Function (CCF) associated with Service Switching Function (SSF).
- FE3: Not used.
- FE4: Terminating CCF.
- FE5: Terminating CCAF.
- FE6: Service Control Function (SCF).
- FE7: Service Data Function in the Originating network [SDF(ca)].
- FE8: Specialized Resource Function (SRF).
- FE9: Service Data Function in the Terminating network [SDF(ci)].

NOTE – In CS-1, the CCF and SSF are assumed to have a relationship which is not externally visible and which is therefore not subject for standardization.

It can be assumed that descriptions of FEs for non-IN is similar to an IN description.

With reference to 3.3/Q.1214, a description of these FEs is given below:

The CCA Function (CCAF)

The CCAF is the Call Control Agent (CCA) Function that provides access for users. It is the interface between user and network Call Control functions. It:

- a) provides for user access, interacting with the user to establish, maintain, modify and release, as required, a call or instance of service;
- b) accesses the service-providing capabilities of the Call Control Function (CCF), using service requests (e.g. set-up, transfer, hold, etc.) for the establishment, manipulation and release of a call or instance of service;
- c) receives indications relating to the call or service from the CCF and relays them to the user as required;
- d) maintains call/service state information as perceived by this functional entity.

The CC Function (CCF)

The CCF is the Call Control (CC) Function in the network that provides call/connection processing and control. It:

- a) establishes, manipulates and releases call/connection as “requested” by the CCAF;
- b) provides the capability to associate and relate CCAF functional entities that are involved in a particular call and/or connection instance (that may be due to SSF requests);
- c) manages the relationship between CCAF functional entities involved in a call (e.g. supervises the overall perspective of the call and/or connection instance);
- d) provides trigger mechanisms to access IN functionality (e.g. passes events to the SSF).

The SS Function (SSF)

The SSF is the Service Switching (SS) Function, which associated with the CCF, provides the set of functions required for interaction between the CCF and a Service Control Function (SCF). It:

- a) extends the logic of the CCF to include recognition of the service (service control triggers) and to interact with the SCF;
- b) manages signalling between the CCF and the SCF;
- c) modifies call/connection processing functions (in the CCF) as required to process requests for IN and non-IN provided service usage under the control of the SCF.

The SC Function (SCF)

The SCF is a function that commands call control functions in the processing of IN provided and/or custom service requests. The SCF may interact with other functional entities to access additional logic or to obtain information (service or user data) required to process a call/service logic instance. It:

- a) interfaces and interacts with Service Switching Function/Call Control Function, Specialized Resource Function (SRF) and Service Data Function (SDF) functional entities;
- b) contains the logic and processing capability required to handle IN-provided service attempts.

The SD Function (SDF)

The SDF contains customer and network data for real time access by the SCF in the execution of an IN provided service. It interfaces and interacts with SCFs as required.

NOTE – The SDF contains data relating directly to the provision or operation of IN provided services. Thus it does not necessarily encompass data provided by third party such as credit information, but may provide access to these data.

The SR Function (SRF)

The SRF provides the specialized resources required for the execution of IN and non-IN provided services (e.g. digit receivers, announcements, conference bridges, etc.). It:

- a) interfaces and interacts with SCF and SSF (and with the CCF);
- b) may contain the logic and processing capability to receive/send and convert information received from users;
- c) may contain functionality similar to the CCF to manage bearer connections to the specialized resources.

For the purposes of this Recommendation, the CCAF is identical with the CCA of Recommendation Q.71. The CCF is based on the corresponding Q.71 ISDN definitions but modified for the use in IN. The enhanced Basic Call Model of IN defines standard Detection Points (DPs) at which IN service feature logic instances can be invoked. These DPs correspond to the Q.71 “hooks” where an ISDN supplementary service interfaces to the Basic Call Model. For the purposes of this Recommendation, relationships R_j, R_n, R_m are outside the scope of this Recommendation and are identical with those defined in Recommendation Q.71. For the purposes of this Recommendation, R_s is identical with relationship r₂ in Recommendation Q.71, since it involves the control of a connection between CCF and SRF in order to provide specialized resources such as tones and announcements. Network capabilities common to a number of supplementary services for user interaction and their switching and signalling requirements are also outside the scope of this Recommendation. Finally, as the R_p and R_r relationships are nationally dependent, only the relation R_q is in the scope of this Recommendation.

This Recommendation treats the case where there is no transfer of the user’s service profile information and SDF(ci) will be accessed for any query (e.g. validation request) on or update (e.g. threshold update) of the ITCC user’s data. Note that the SDF(ci) does not belong to the card acceptor and it is usually located outside the national boundary.

The SDF associated with the card acceptor network may contain some data related to the provision of ITCC service to the visiting user. For example, SDF(ca) may contain information on agreements with other ITCC service providers. No additional security for interworking is provided other than such knowledge of existence of service agreements between service providers. SDF(ca) may also contain data on security measures, e.g. the number of retries allowed by the originating network to an ITCC user attempting to access ITCC service. It is also assumed that SDF(ci) will also be able to check that a service agreement exists with the service provider of the invoking SCF.

7.7 Information Flows for ITCC

The Information Flows (IFs) and their contents (Information Elements, IEs) are based on those developed by Study Group 11 for the IN architecture, as described in clause 6/Q.1214. The individual IFs are described in 7.7.2 of this Recommendation. Whether IFs are confirmed or unconfirmed and of type req. ind. or resp. conf. is described here. Information flows and information elements for non-IN can be considered to be equivalent.

In the information flow diagrams the CS-1 IF names are shown in mixed case lettering, without the req. ind. or resp. conf. descriptors. The full descriptions of these IFs are in 7.7.2 (The individual IFs). IFs derived from Recommendation Q.71 are shown in upper case italic letters, with type descriptors.

The IFs do not show any IFs relating to timer control of interaction between FEs. Not all error paths are considered.

7.7.1 ITCC procedures

The ITCC user invokes access to ITCC service by setting up a call to an ITCC card acceptor network. The user is then connected to an SRF which provides the mechanism of interaction between the ITCC user and the ITCC card acceptor network for the collection of information to enable access to the service.

The interactions between the ITCC user and the SRF are assumed to be by DTMF in-band signalling. The SRF also provides voice prompts but specific content of the announcements is beyond the scope of this Recommendation.

The sequence (e.g. PAN, PIN, Called Number) in which the information is sent from the ITCC user to the network is a national matter, and is also beyond the scope of this Recommendation.

An outline of the sequence in which the procedures are invoked is shown in Figure 2, exit and error paths are not included.

The main body of text of this Recommendation contains the description of the validation and call disposition procedures for the ITCC service as defined in Recommendation E.113. Other procedures that are out of the scope of standardization (national dependent) are reported in the appendixes.

7.7.1.1 Validation procedure

The ITCC service is based on an automatic validation procedure that implies that the call handling Administration will query the database of the card issuing Administration to validate telephone charge cards used by customers who are making a call in a country other than their own.

Recommendation E.113 “Validation procedures for the international telecommunications charge card service” defines the procedures for the validation process between Administrations. The validation process foresees the following messages:

- **Authorization Request (M)**: is a message from the card acceptor network to the card issuer network which provides details of an attempt to use a telephone charge card (i.e. card validation).
- **Request Response (M)**: is a message from the card issuer network to the card acceptor network to provide either a positive or negative response to the authorization request.

The following is a high-level description of the network actions required in order to validate the ITCC service.

According to Recommendation E.118 describing the card format, the identity of the ITCC card issuer can be deduced from the Primary Account Number. Moreover, if there is a service agreement between the card acceptor and the card issuer, then the SDF associated with the card acceptor network may contain some data related to the agreements with other ITCC service providers.

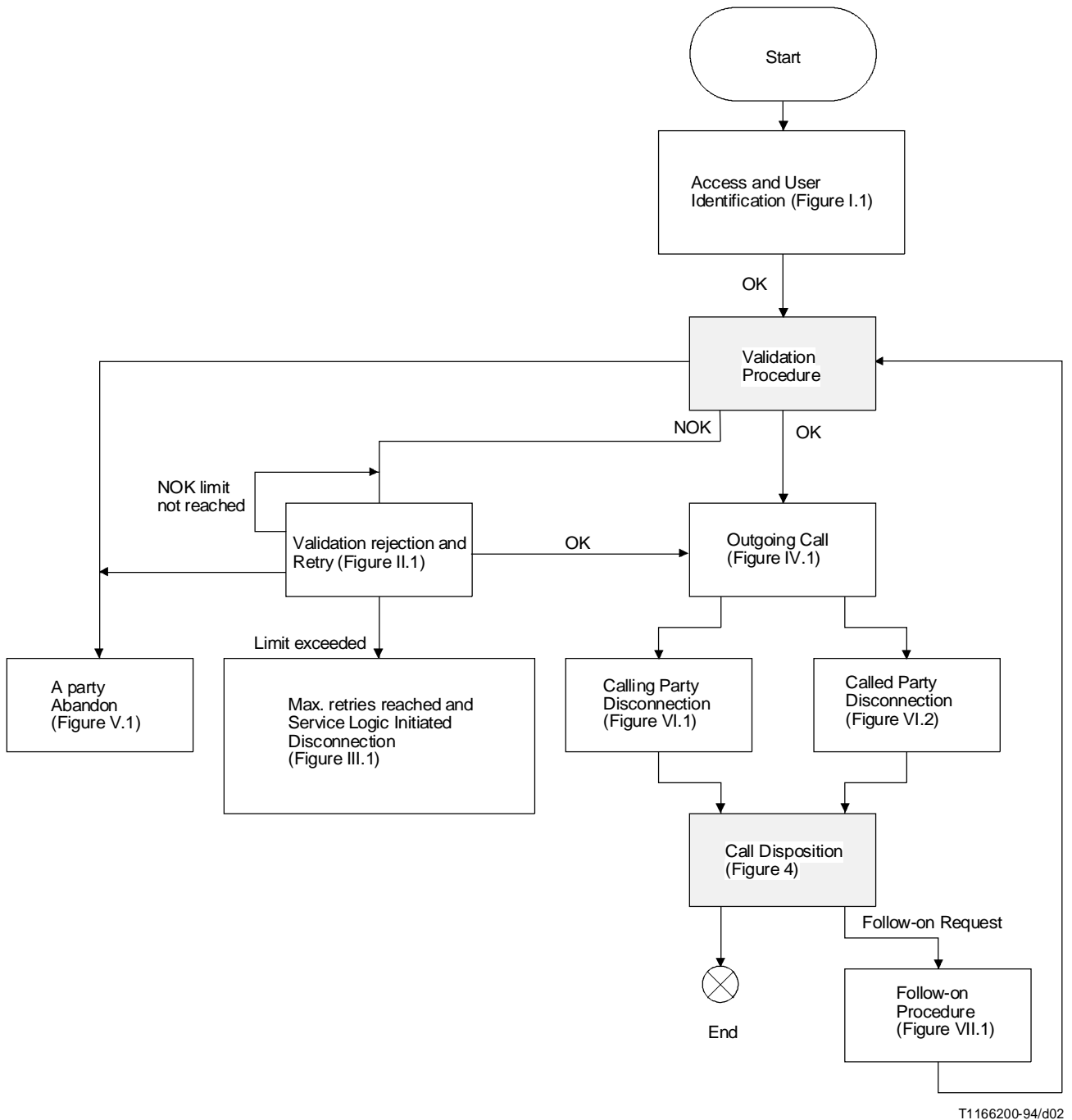

T1166200-94/d02

FIGURE 2/Q.86
Outline of sequencing of ITCC procedures

Procedures for the SRF to the interface with the calling user in order to collect his information or to provide announcements is national in nature and beyond the scope of this Recommendation.

Outline

- 1) The originating network requires the card issuer network to validate (Authorization Request) the card.
- 2) The card issuer network undertakes authentication checks and sends back the result (Request Response).

- 3) Decision:
- if successful, continue the ITCC procedures;
 - if unsuccessful and subsequent attempts allowed, advise user of failure and restart the user validation;
 - if unsuccessful and no subsequent attempts allowed, advise user and release the call.

7.7.1.1.1 Information flow diagram

The following diagram (Figure 3) shows the validation procedure.

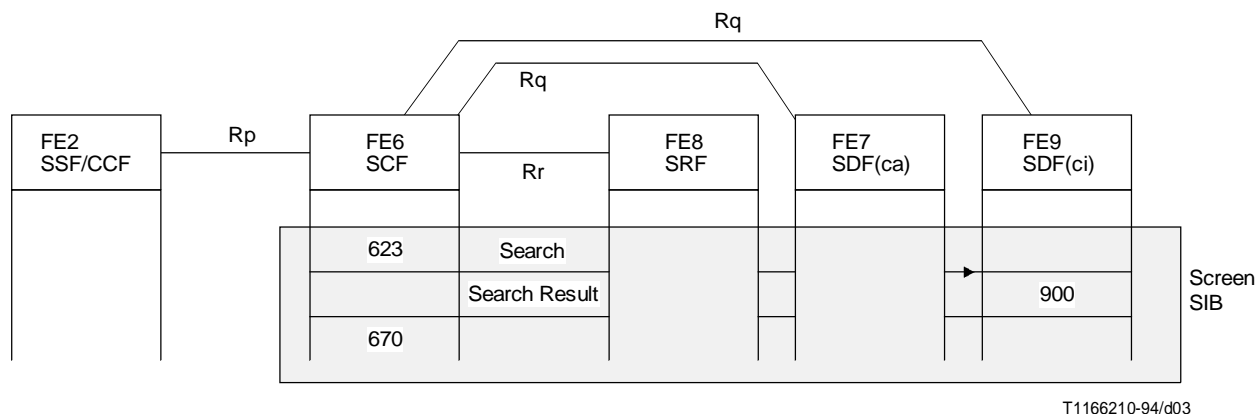

FIGURE 3/Q.86
Validation procedure

The validation is undertaken by the ITCC card issuer using the information received by the SCF(ca) including PAN, PIN and eventually the Called Number¹⁾. If authentication is successful, the ITCC service logic in the originating network can continue. If authentication fails, action could proceed to “Authentication rejection and retry” (see Figure II.1) or terminate the call to “Maximum retries reached” (see Figure III.1).

7.7.1.2 Call disposition procedure

Recommendation E.113 “Validation procedures for the international telecommunications charge card service” foresees, based on bilateral agreement, the procedure for the transmission of call details to the card issuing Administration at the end of each ITCC call. This procedure, uses the following message:

- **Call Disposition (O)**: is a message from the card acceptor network to the card issuer network to track usage of the card against the credit limit of the customer and gather other statistics. The main purpose of this additional message is to provide, on a timely basis, better control against potential fraudulent use of the charge card.

¹⁾ PAN (max. 19 digits) PIN (Max. 4 digits)
 MII = 89
 CC CLD No. (Recommendation E.164)
 Issuer ID CLG No. (Recommendation E.164)
 ACT No.

The following is a high-level description of the network actions required in order to update the threshold in SDF(ci).

Outline

- 1) The originating network sends to the card issuer network the call details including the estimated charge as soon as the call is completed.
- 2) The card issuing network updates the usage value of the card and sends back a response.
- 3) If follow-on is foreseen, a trigger condition was met during the called party initiated disconnection; the action proceeds to “Follow-on” (see Figure VII.1).

It is assumed that the appropriate points of control for detecting call abandon of the Calling party and the call disconnect of Calling/Called party will always be appropriately armed.

Call details information to be sent in a Call Disposition message must be obtained from the SSF upon completion of a call. Procedures to provide this information by SSF to SCF are national in nature and beyond the scope of this Recommendation (see Figure IV.1).

7.7.1.2.1 Information flow diagram

The following diagram (Figure 4) shows the Call Disposition procedure.

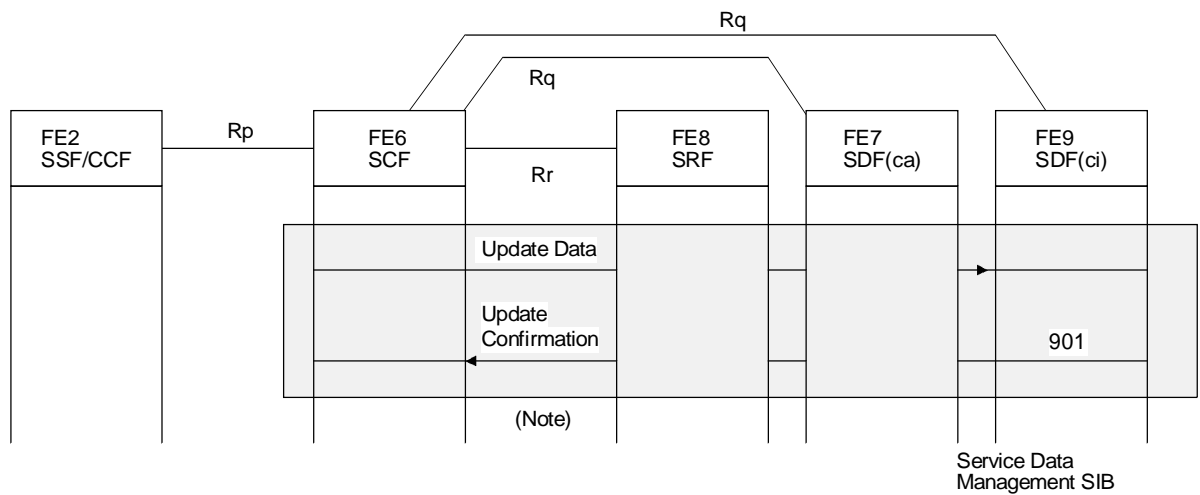

T1166220-94/d04

NOTE – If follow-on is foreseen, a trigger condition was met during the called party initiated disconnection (see Figure VI.2, FEA 603), the action now proceeds to “Follow-on Recognition” (see Figure VII.1).

**FIGURE 4/Q.86
Call Disposition procedure**

The Call Disposition procedure updates the ITCC service profile adding details related to the call documentation including the estimated call charge. Note that the confirmation response from the SDF(ci) to SCF(ca) could be not requested.

7.7.2 Definition of individual information flows

The Information Flows (IFs) contained in this subclause are those described in clauses 5 and 6/Q.1214. The information elements (IEs) shown as those which are either mandatory (M) or Optional but needed for ITCC service (O). All of them are related to the SCF-SDF interface.

NOTE 1 – As far as the SCF-SDF interface is concerned, Study Group XI/4 decided to use the X.500 protocol for the SCF-SDF interface. After the September 1994 meeting, this Recommendation will be updated in order to consider the necessary modifications.

The IFs are also cross-referenced to the Service Independent Building Block (SIB) in which the IF is described in clause 5/Q.1214.

NOTE 2 – Based on the SG 4/11 final decision, also the Service Independent Building Block (SIB) description in clause 5/Q.1214 has to be updated accordingly.

The IFs related to the SSF-SCF and SRF-SSF interfaces, as stated in 7.7.1, are outside the scope of this Recommendation as they refer to a part of the architecture that may be implemented both using IN/non-IN model. For simplicity, these IFs are shown in Appendix I.

7.7.2.1 Relationship Rq (SCF-SDF)

The abbreviations for the SIBs and the relevant subclause numbers in Recommendation Q.1214 are:

- Screen Screen 5.2.8/Q.1214
- Service Data Management SDM 5.2.9/Q.1214

The Screen SIB provides the capability for the SCF to perform a comparison of an identifier against a list located in a specified storage space in the SDF.

The Service Data Management SIB provides the capability for the SCF to: retrieve, replace, increment and decrement data in a specified storage space in the SDF.

Non-IN use of relationship Rq for SCF-SDF is essentially the same as that described using IN terminology.

7.7.2.1.1 SCF to SDF flows

The Query IF is used to query an item of data held in the SDF.

The Update Data IF when requested entails an automatic execution of the update.

Query req. ind. – confirmed IF (SDM, Screen, Trans.)

IEs:	Database Id	O
	Requested Info Type	O
	Information Key	M

Update Data req. ind. – confirmed IF (SDM, LCI)

IEs:	Function Type	O
	Database Id	O
	Updated Info	M
	Information Key	M

7.7.2.1.2 SDF to SCF flows

The Query Result IF is the response to a Query IF. Note that in INAP this IF maps on to the RESULT part of the Query operation.

The Update Confirmation IF is the response to an Update Data IF. Note that in INAP this IF maps on to the RESULT part of the Update Data operation.

Query Result resp. conf. – unconfirmed IF (SDM, Screen, Trans.)

IEs:	Requested Info	M
------	----------------	---

Update Confirmation resp. conf. – unconfirmed IF (SDM, LCI)

IEs:	Outcome	M
------	---------	---

7.8 SDL diagrams for ITCC

The SDL diagrams depicted in Figure 5 describe the sequencing of the Information Flows of 7.7. The SDL are related to the SCF-SDF interface. See Figure 5a.

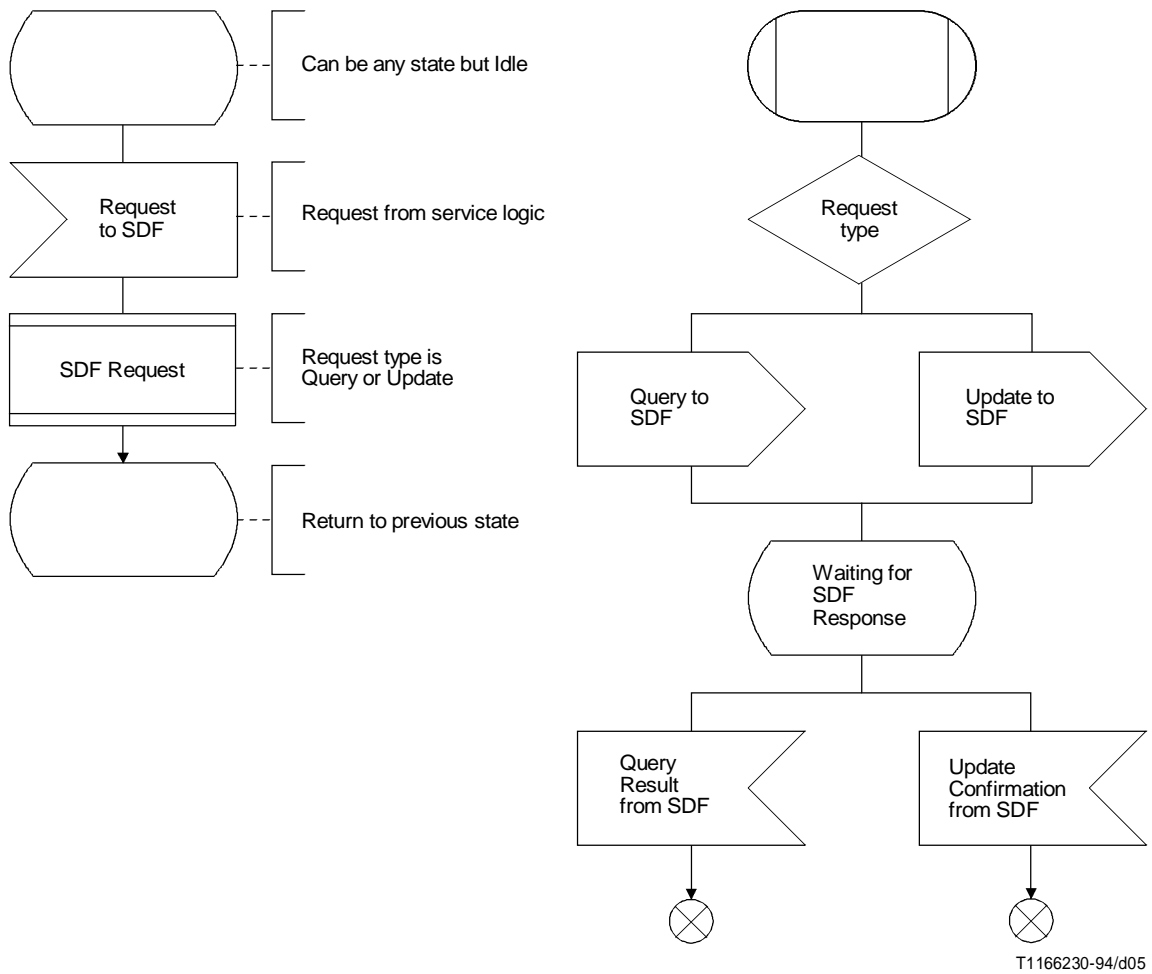

FIGURE 5a/Q.86
SDLs diagram for SCF

7.8.1 Card validation procedure

This paragraph describes two possible solutions to provide a card validation procedure; the first one uses the Retrieve operation, the second one shows the Screen operation. See Figures 5b and 5c.

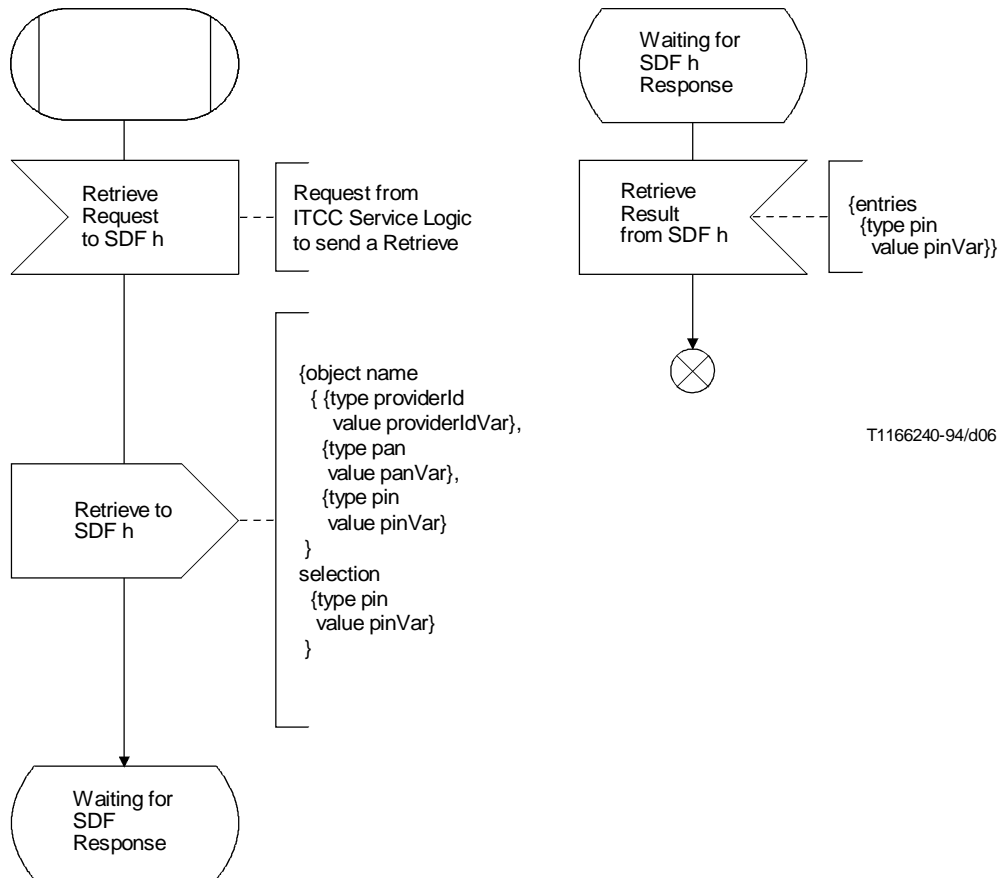

FIGURE 5b/Q.86
First example of SDL procedure for card successful validation

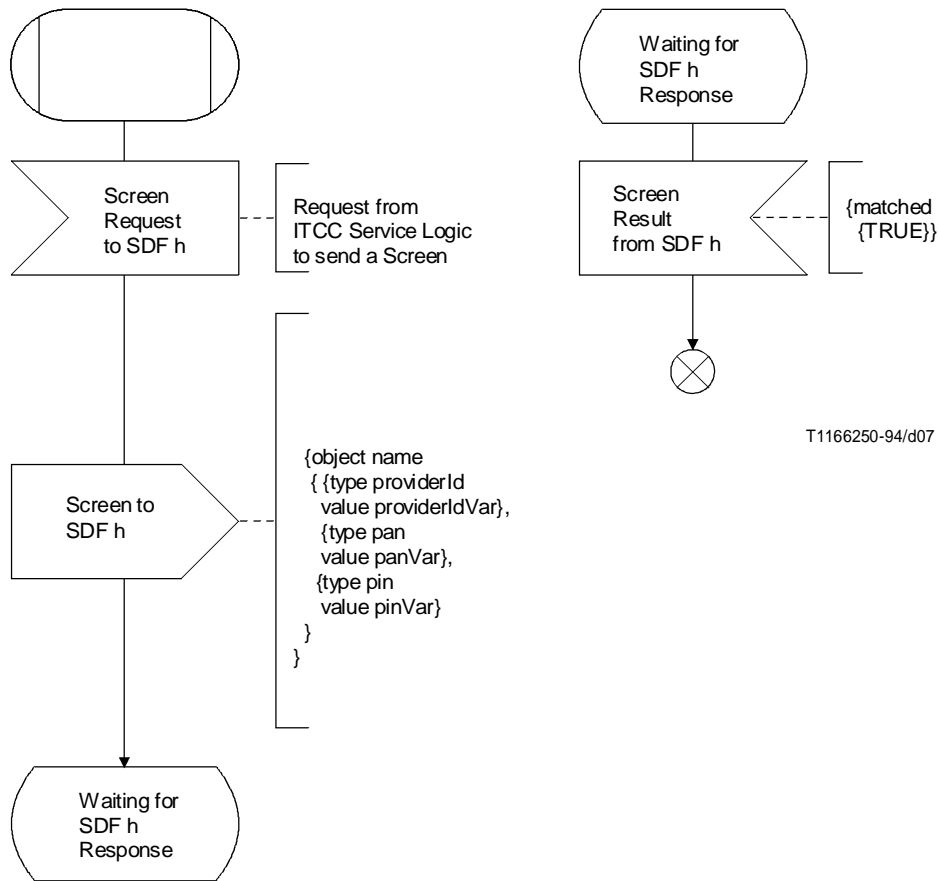

FIGURE 5c/Q.86
Second example of SDL procedure for card successful validation

7.8.2 Call Disposition procedure

See Figure 5d.

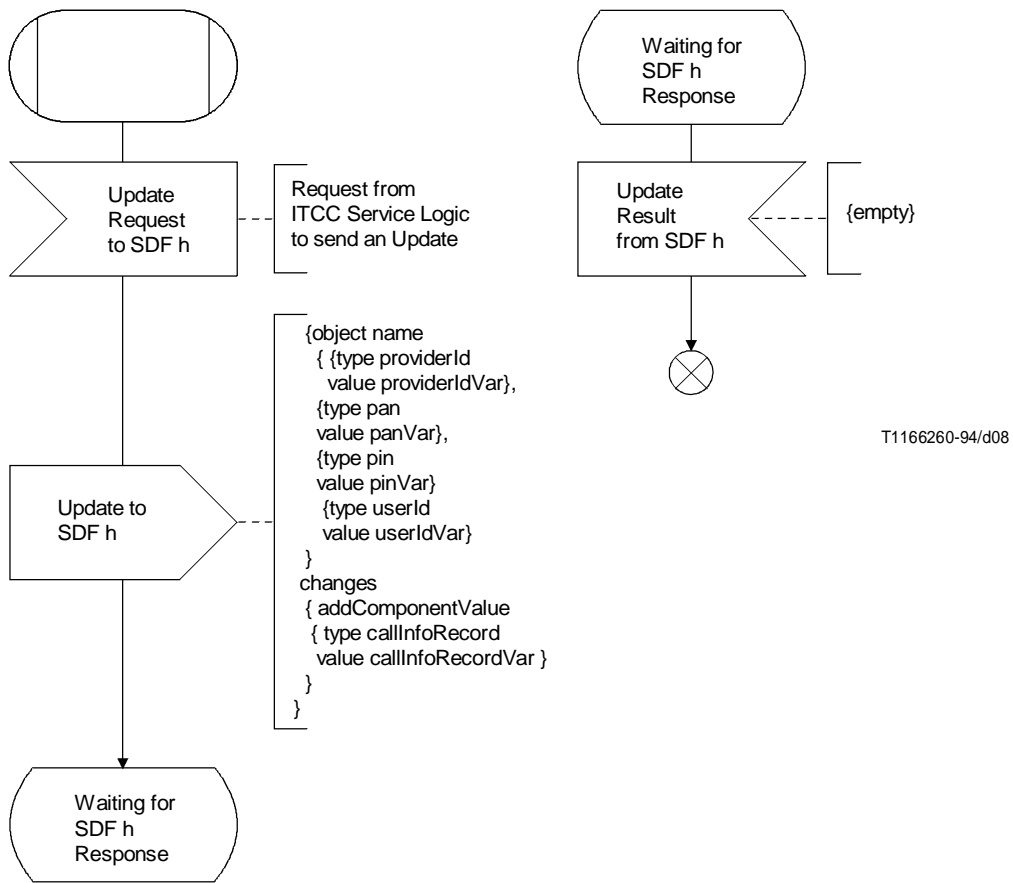

FIGURE 5d/Q.86

Example of SDL procedure for call disposition at the end of a successful call

7.9 Functional Entity Actions

FEA: 200 [A]

- On detection of the request for ITCC service, the SSF formulates and sends Initial DP req. ind. to SCF.
- Suspend the call processing until the validation is complete.

FEA: 201 [E]

- Receive and react to DISCONNECT req. ind. from CCAF.
- Formulate and send RELEASE req. ind. to SRF to Release resources.
- Disconnect.
- Stop charging, if applicable.

FEA: 202 [E]

- Receive and react to RELEASE req. conf. from CCAF.
- Formulate and send Event Report BCSM req. ind. to SCF, if required.
- Continue clearing call as per Recommendation Q.71.

FEA: 203 [F.1]

- Receive and react to DISCONNECT req. ind. from CCAF.
- Formulate and send Event Report BCSM req. ind. to SCF.

FEA: 210 [A]

- Receive Request Report BCSM Event req. ind. from SCF.
- Arm Detection Points as EDP-N to report user abandon (before answer – DP 10) or user disconnect (after answer – DP 9).

FEA: 211 [A, G]

- Receive and react to Establish Temporary Connection req. ind. from SCF.
- Formulate and send SETUP req. ind. to SRF to establish a connection to it.

FEA: 212 [D, H]

- Receive and react to Disconnect Forward connection req. ind. from SCF.
- Formulate and send Release req. ind. to SRF.

FEA: 214 [D]

- Receive Request Report BCSM Event req. ind. from SCF.
- Arm Detection Points as EDP-R or EDP-N to report route select failure (DP 4), B busy (DP 5), B no answer timeout (DP 6), and B clear (DP 9).

NOTE 1 – If follow-on call is allowed, the DPs will be armed as EDP-R, or else as EDP-N.

FEA: 215 [D]

- Receive and react Furnish Charging Information req. ind. from SCF.

FEA: 216 [D]

- Receive and react ApplyCharging Information req. ind. from SCF.

FEA: 217 [D]

- Receive and react to Connect req. ind. from SCF.
- Take appropriate action for Basic Call Set-up.

FEA: 219 [F.1, F.2]

- Formulate and send Apply Charging report req. ind. to communicate to the SCF the amount for the call.

FEA: 250 [A, G]

- Receive and react to SETUP resp. conf. from SRF.
- Establish a relationship between the leg between the calling party and the SSF/CCF, and the leg between the SSF/CCF and the SRF.
- Through-connect calling party to SRF.

FEA: 251 [E]

- Receive and react to RELEASE resp. conf. from SRF.
- If no other RELEASE resp. conf. outstanding:
 - formulate and send Event Report BCSM req. ind. to SCF, if required.

FEA: 252 [D, H]

- Receive and react to RELEASE resp. conf. from SRF.

NOTE – The SRF is being released in the middle of a procedure and the call is not yet being terminated.

FEA: 270 [F.2]

- Receive and react to RELEASE req. ind. from forward direction.
- Formulate and send Call Information Report BCSM req. ind. to SCF to report called party release (EDP-N).
- Continue clearing call as per Recommendation Q.71.

FEA: 600 [A]

- Receive and react to Initial DP req. ind. from SSF/CCF.
- Formulate and send Request Report BCSM Event req. ind. to SSF/CCF to arm Detection Points as EDP-N for calling party abandon (DP 10) and disconnect (DP 9), if the latter is required.
- Formulate and send Retrieve req. ind. to SDF(ca) to get the SDF(ci) address if it cannot be deduced from the PAN and the appropriate language to use for announcement (optional).

FEA: 601 [E]

- Receive and react to Event Report BCSM req. ind. from SSF/CCF.

FEA: 602 [F.1, F.2]

- Receive and react to Apply Charging Report req. ind. from SSF/CCF.
- Go to Call Disposition procedure (see Figure 3).

FEA: 603 [F.1]

- Receive and react to Event Report BCSM req. ind. from SSF/CCF.
- If follow-on is foreseen, a trigger condition is met; after the call disposition procedure (see Figure 4), the SCF will initiate the follow-on recognition procedure (see Figure VII.1).

FEA: 605 [F.2]

- Receive and react to Event Report BCSM req. ind. from SSF/CCF.

FEA: 610 [A]

- Receive and react to Retrieve Result req. conf from SDF(ca) by storing the SDF(ci) address and identifying the correct language to use in announcements.
- Formulate and send Establish Temporary Connection req. ind. to SSF/CCF to instruct it to connect to SRF.

FEA: 620 [A, G]

- Receive and react to Assist Request Instructions from SRF req. ind. from SRF.
- Formulate and send Prompt and Collect User Information req. ind. to SRF to prompt user to input his identity in the form of his PIN number.

FEA: 621 [A]

- Receive and react to Collected User Information resp. conf. from SRF.
- Formulate and send a Prompt and Collect User Information req. ind. to SRF to prompt user to input the destination number.

FEA: 622 [A, B, G]

- Receive and react to Collect User Information resp. conf. from SRF.
- Formulate and send Prompt and Collect User Information req. ind. to SRF to prompt user to input his PIN.

FEA: 623 [Figure 3, B]

- Start the Validation procedure.
- Formulate and send a Query req. ind. to SDF(ci) in order to validate the card. Go to the outgoing call procedure.

FEA: 624 [C]

- Receive and react to SR Report resp. ind from SRF.
- Formulate and send Update req. ind. to SDF(ci) to communicate the SDF(ci) the failed attempts record, if not already done.
- Activate security measures to prevent access re-attempts.

FEA: 650 [B]

- On first execution start the SCF counter of validation retries using as the allowed limit the smaller of the two values retrieved from SDF(ca) and SDF(ci).
- Modify counter value as required.
- Formulate and send Update Data req. ind. to SDF(ci) to record numbers of validation failures.

FEA: 669 [4]

- Receive and react to Update Result resp. conf. from SDF(h).
- If the threshold is not exceeded go to FEA xx in “Follow-on allowed” procedure.
- If authentication fails go to FEA xx in “Disconnection” procedure.

FEA: 670 [Figure 3]

- Receive and react to Query Result resp. conf. from SDF(ci).
- If authentication is successful, go to the outgoing call procedure (Figure IV.1);
- If authentication fails and it was the first time go to Validation rejection and retry procedure (Figure II.1).

FEA: 671 [B]

- On first execution formulate and send a Query req. ind. to SDF(ci) to obtain value of validation retry counter allowed from ITCC card issuer (optional).

FEA: 672 [B]

- Receive and react to Query Result req. ind. from SDF(ci).
- Formulate and send Query req. ind. to SDF(ca) to obtain value of local validation retry counter allowed from the originating (local) network (optional).

FEA: 673 [B]

- Receive and react to Query, Result resp. conf. from SDF(ci).
- If authentication is successful, go to the “outgoing call” procedure.
- If authentication fails go to FEA 650 in Validation Retry procedure to update record of failure.

FEA: 674 [B]

- Receive and react to Update Confirmation resp. conf. from SDF(ci).
- Test if retry counter limit is reached.
- If reached, go to Maximum retries reached (Figure III.1).
- If not reached formulate and send Prompt and Collect User Information req. ind. to SRF to prompt user to input his PAN.

FEA: 675 [C]

- Formulate and send Play Announcements req. ind. to SRF to advise the user that the maximum retries number is reached.

FEA: 678 [C]

- Receive and react to Update Conf. resp. conf. from SDF(ci).
- Formulate and send Release Call req. ind. to SSF/CCF.

FEA: 679 [C]

- Receive and react to Release Call resp. conf. req. ind. from SSF/CCF.

FEA: 700 [A, B]

- Receive and react to Retrieve req. ind. from SCF.
- Extract Data request.
- Formulate and send Retrieve Result resp. conf. to SCF.

FEA: 800 [A, G]

- Receive and react to SETUP req. ind. from SSF/CCF.
- On successful establishment of connection:
 - formulate and send SETUP resp. conf. to SSF/CCF;
 - formulate and send Assist Request Instruction from SRF req. ind. to SCF.

FEA: 801 [D, E, H]

- Receive and react to RELEASE req. ind. from SSF/CCF.
- Disconnect resources.
- Formulate and send RELEASE resp. conf. to SSF/CCF.

FEA: 810 [A, B, G]

- Receive and react to Prompt and Collect User Information req. ind. from SCF.
- Play announcement requested by SCF.
- Collect information.
- On successful receipt of information, or on error condition, formulate and send Collected User Information resp. conf. to SCF.

FEA: 811 [C]

- Receive and react to Play announcement req. ind. from SCF.
- Play announcement requested by SCF.
- Formulate and send a SR Report to SCF.

FEA: 900 [3, B]

- Receive and react to Screen req. ind. from SCF.
- Perform the match required.
- Formulate and send Screen Result resp. conf. to SCF.

FEA: 901 [4, B]

- Receive and react to Update req. ind. from SCF.
- Perform the action required.
- Formulate and send Update Result resp. conf. to SCF.

FEA: 902 [B]

- Receive and react to Retrieve req. ind. from SCF.
- Retrieve data.
- Formulate and send Retrieve Result resp. conf. to SCF.

7.10 Allocation of FEs to physical locations

The functional entities depicted in Figure 1 include both IN and non-IN models. Therefore the functional entity and the physical entity relationship can be considered identical for either model.

The PE used for the mapping are the following:

Service Switching Point: The SSP provides switching functionalities, and if it is a local exchange, provides the user with access to the network. The SSP allows access to the service after a request for the service has been detected. It communicates with other PEs such as an SCP. Functionally the SSP contains CCF, SSF, and, if the SSP is a local exchange, a CCAF. An SCF, an SRF and an SDF may be optionally contained in the SSP.

Service Network Access Point: This PE contains only the CCAF and CCF FEs. The SNAP cannot communicate with an SCF but has the capability to recognize a call requiring the service and route the call to an SSP.

Service Control Point: The SCP contains the Service Logic Programs to provide services. SCP and SSP are connected by signalling network. An SCP contains an SCF and an SDF.

Intelligent Peripheral: The IP provides resources for the user interaction with the network. Functionally an IP contains an SRF.

Service Switching and Control Point: This is a combined SCP and SSP in a single node. Functionally it contains an SCF, SDF, CCAF, CCF and SSF. An SSCP may optionally contain an SRF.

Service Data Point: The SDP contains the customer and network data which is accessed during the execution of a service. Functionally the SDP contains SDF.

PE/FE	SSF FE6	CCF/SSF FE2	SDF(ca)	SDF(ci) FE9	SRF FE8
SCP	X	-	X	X	-
SSP	-	X	X	X	X
IP	-	-	-	-	X
SDP	-	-	X	X	-
SSCP	X	X	X	X	X
NAP	-	X	-	-	-
X Possible configurations - Not recommended					

Scenario 1

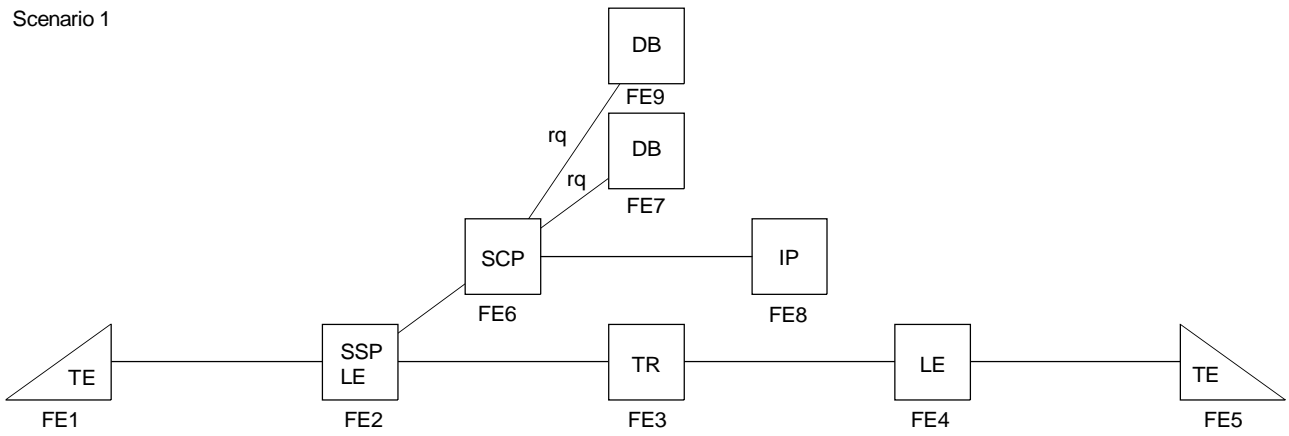

Scenario 2

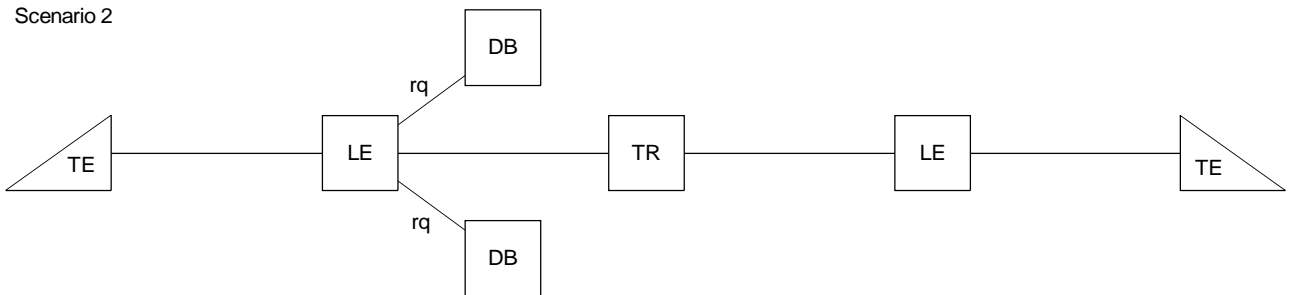

Scenario 3

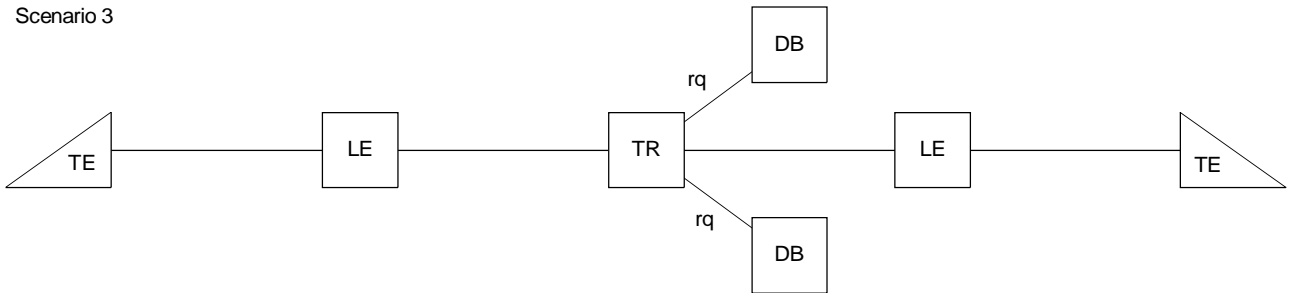

T1166270-94/d09

PE/FE	SCF	CCF/SSF	SDF o	SDF h	SRF
SCP	c	–	c	c	–
SSP	–	c	o	o	o
IP	–	–	–	–	c
SDP	–	–	c	c	–
SSCP	c	c	c	c	o
NAP	–	c (CCF only)	–	–	–

c Core
 o Optional
 – Not recommended

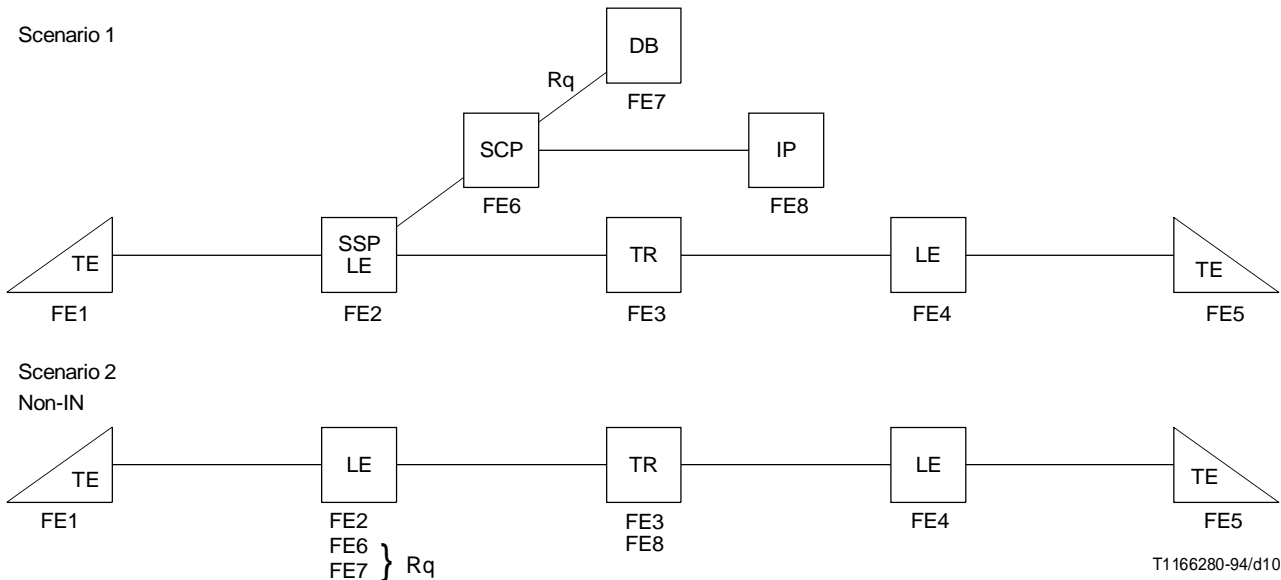

NOTE – Non-IN configurations may not have similar relationships to IN.

Appendix I

Access and identification procedure

(This appendix does not form an integral part of this Recommendation)

Regarding the access procedures, three different types can be foreseen: card reader procedure, auto access procedure and operator procedure. Since the choice of one of them is a national decision, it is out of the scope of this Recommendation. In this subclause an example of an ITCC call originated from a telephone not equipped with card reader using an auto access procedure (i.e. without operator assistance) is shown.

The following is a high-level description of the network actions required when a user requests access to the ITCC service.

Outline

- 1) Service Access Code (SAC) and the Primary Account Number (PAN) input by the user.
- 2) Recognition of SAC, suspension of the call processing in CCF, information flow to SCF advising initiation of ITCC request.
- 3) The card acceptor's SCF, using the PAN information, applies call screening and retrieves from its own DB the card issuer identification information. Other call screening could be related to the retrieval of the appropriate language to use for the subsequent announcements. If it could be assumed that the ITCC card user DB can be deduced from the PAN number, the retrieve is not necessary.
- 4) Connection of SRF (Establish Temporary Connection).
- 5) Prompt for PIN code and collect it.
- 6) Prompt user to input destination number and collect it.

This solution is only one of the possible implementations at the end of this procedure. Regardless of which implementation is used however, the SCF will have obtained the same information for the call at the end of this procedure.

Information flow diagram

The information flow shows the access and identification procedures. See Figure I.1.

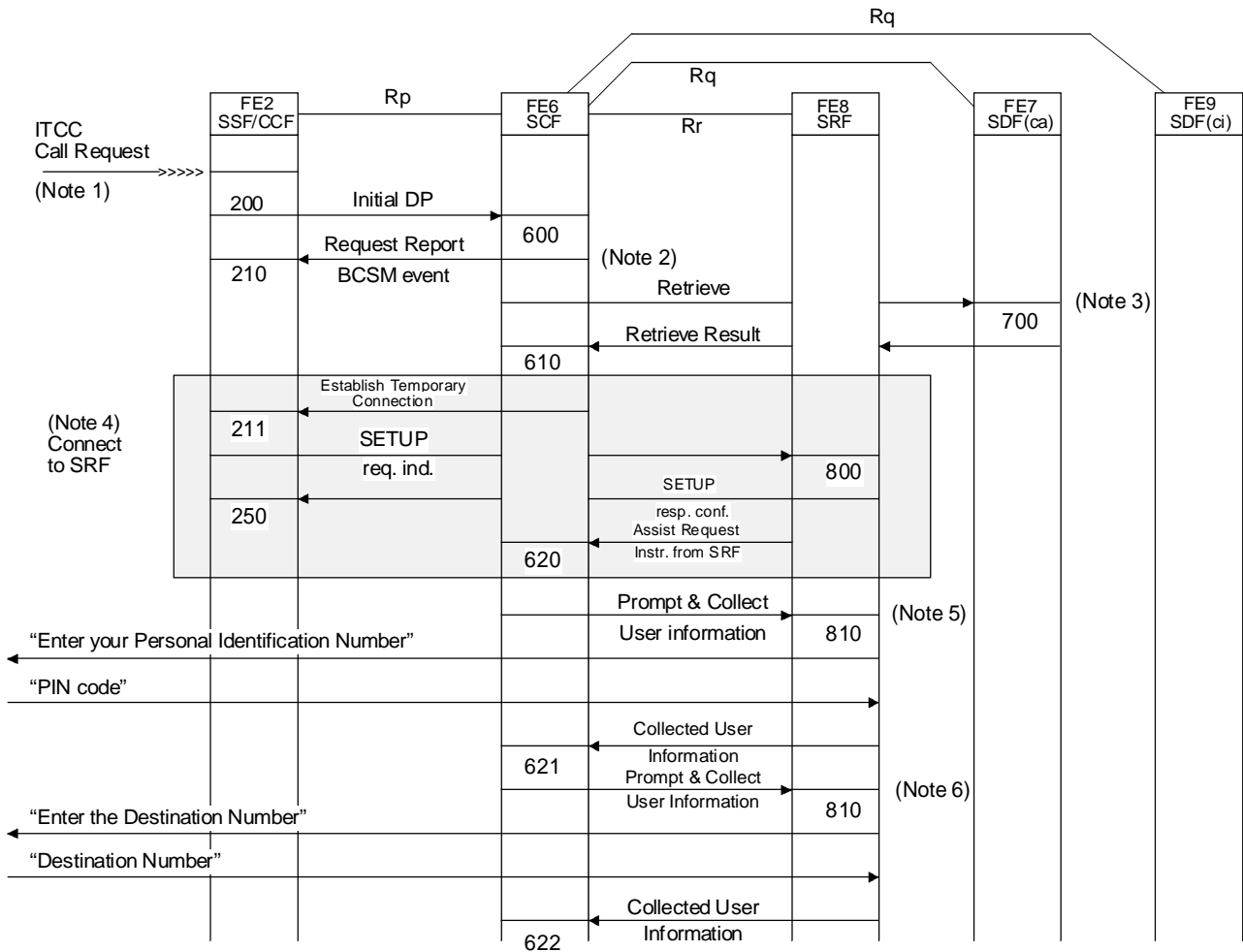

T1166290-94/d11

NOTES

- 1 The contents of SETUP req. ind. from FE1 (CCAF) to FE2 (SSF/CCF) are the SAC, the PAN and the Calling Number if present. This is one possible implementation. Other solutions can be envisaged. The nature of the req. ind. is dependent on the national network in use (PSTN, ISDN, PLMN).
- 2 On initiation of the ITCC service, control points (DPs) are dynamically armed by Request BCSM Event Report req. ind. in order to detect the calling party abandon.
- 3 This IF is optional and could be used to determine particular aspects of the service (e.g. SDM to be sent or country language to be played).
- 4 The order in which the SRF sends the SETUP resp. conf. and the Assist Request Instruction from SRF req. ind. is not significant. There are several SRF connection procedures, related to the physical location of the SRF. This example refers to a case in which there is a direct path between SCP and IP.
- 5 The user is prompted to input his PIN code by dialling digits or using a DTMF tone sender, for example. SCF-initiated disconnection of SRF is assumed, hence the SRF is not allowed to disconnect at the end of the user interaction.
- 6 The user is prompted to input the destination number by the SRF, using Prompt and Collect User Information req. ind. The number is reported to SCF using Collect User Information req. ind.

FIGURE I.1/Q.86

Successful access and identification procedure

Appendix II

Validation Rejection and Retry procedure

(This appendix does not form an integral part of this Recommendation)

The Validation Rejection and Retry procedure is used when a charge card validation result is not accepted. Treatment of the call at this point is implementation dependent. Figure II.1 uses a query to service databases to obtain information on services rejection and retry agreements. Using information retrieved, the calling user is requested to re-enter a PAN and PIN. This procedure ends when the SCF has collected the subsequent user information.

Outline

The following is a high-level description of the actions for a validation retry:

- 1) Obtain service/user retry ability from card issuer and/or card accepting databases.
- 2) Request SRF to prompt and collect subsequent PAN/PIN.
- 3) Provide result from SRF to SCF.

Information flow diagram

The information flow shows the Validation and Retry procedure. See Figure II.1.

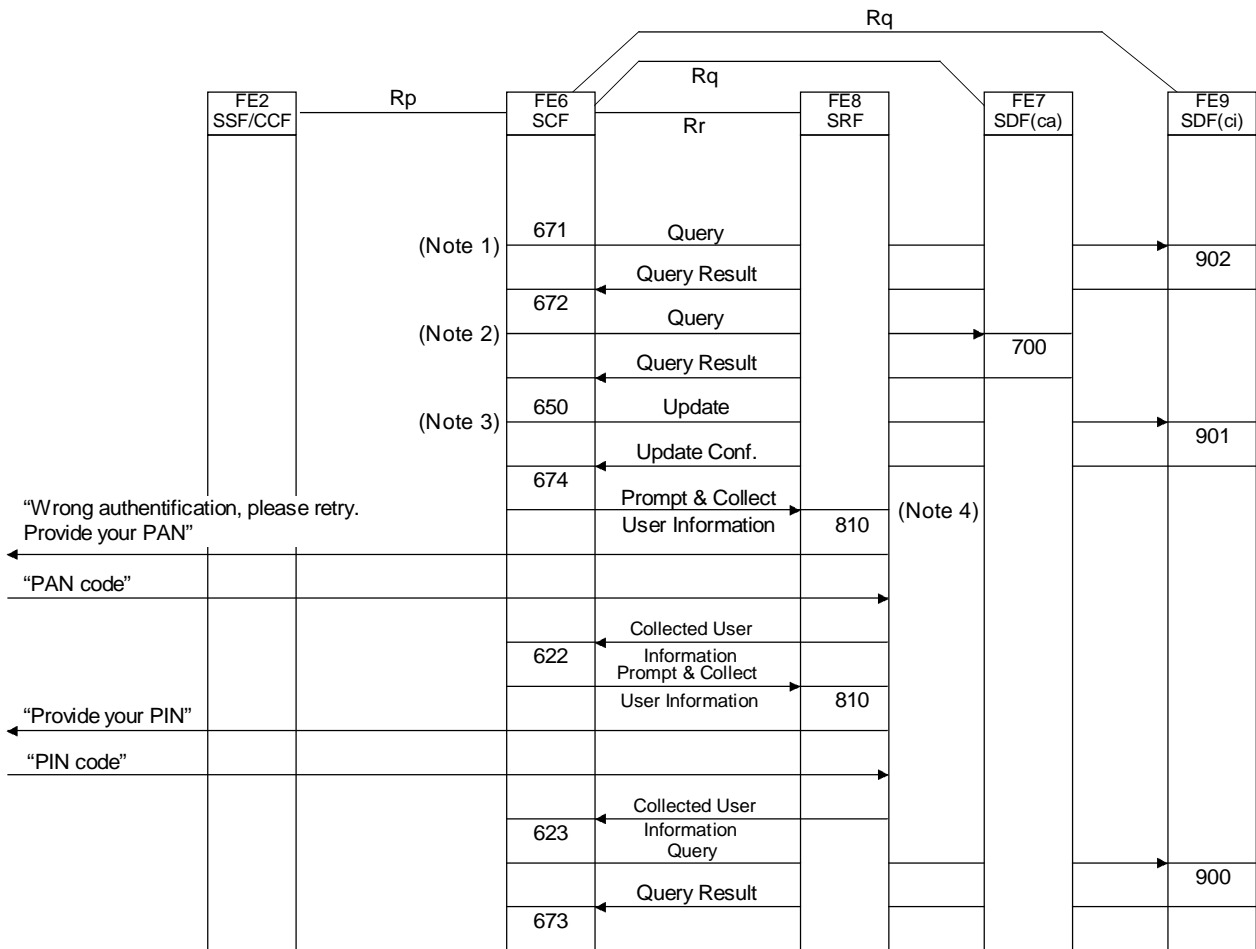

T1166300-94/d12

NOTES

- 1 Once authentication fails, a count must be kept of the number of retry attempts. On first execution of this sequence, the limit set by the ITCC card issuer is retrieved from SDF(ci).
- 2 On first execution of this sequence, the retry limit of originating network of ITCC card acceptor is retrieved from SDF(ca). The counter logic resides in SCF. It is assumed that the SCF would use the smaller of these two values as the allowed limit, should they be different.
- 3 The count of authentication failures is now recorded in SDF(ci) for security and administration purposes.
- 4 If authentication fails, the specific reason for failure should not be advised to the user, for security reasons. Therefore both the PAN and the PIN will need to be re-entered.

**FIGURE II.1/Q.86
Validation rejection and retry procedure**

Appendix III

Maximum retries reached and service logic initiated release procedure

(This appendix does not form an integral part of this Recommendation)

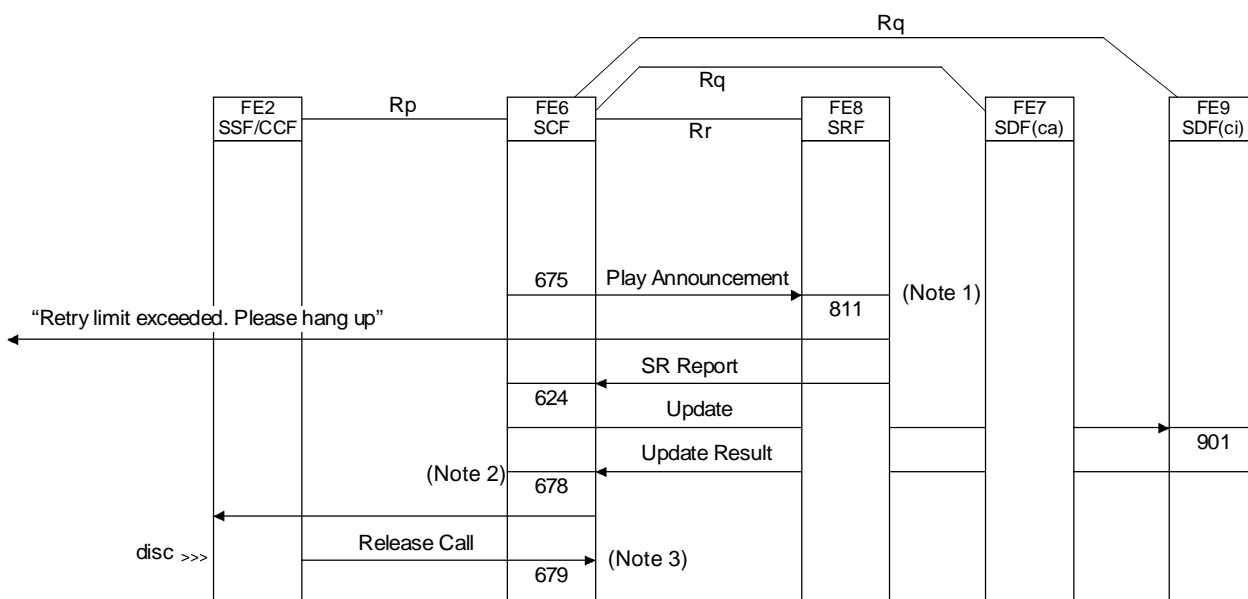

T1166310-94/d13

NOTES

- 1 The SRF now plays a final announcement to the user. SRF-initiated disconnection could be used to disconnect the SRF in this case but has not been shown.
- 2 The SDF(ci) is updated with record of the failed attempts if not already done. Security measures may be required to reject further attempts. The user is advised of failure and requested to hang up. The network then does forced release of the call and disconnects the SRF.
- 3 In the IN environment, the Release call requests a confirmation.

FIGURE III.1/Q.86

Maximum retries reached and network initiated release

Appendix IV

Outgoing call

(This appendix does not form an integral part of this Recommendation)

Outgoing calls from an ITCC user may be a single call, in which the procedure terminates at the end of the call or may allow follow-on (see Appendix VII).

Outline

The following is a high-level description of the actions required to set up an outgoing call:

- 1) Disconnection of SRF.
- 2) Arm triggers to detect call set-up failure and to detect mid-call feature activation (if required) and activate an application timer on "Called party no answer" (if required).

- 3) Furnish charging operation (or other charging operation) for generation of billing record.
- 4) ApplyCharging operation to request information on call consuming.
- 5) Connect to destination number using Connect IF.

Information flow diagram

The information flow shows the outgoing call procedure. See Figure IV.1.

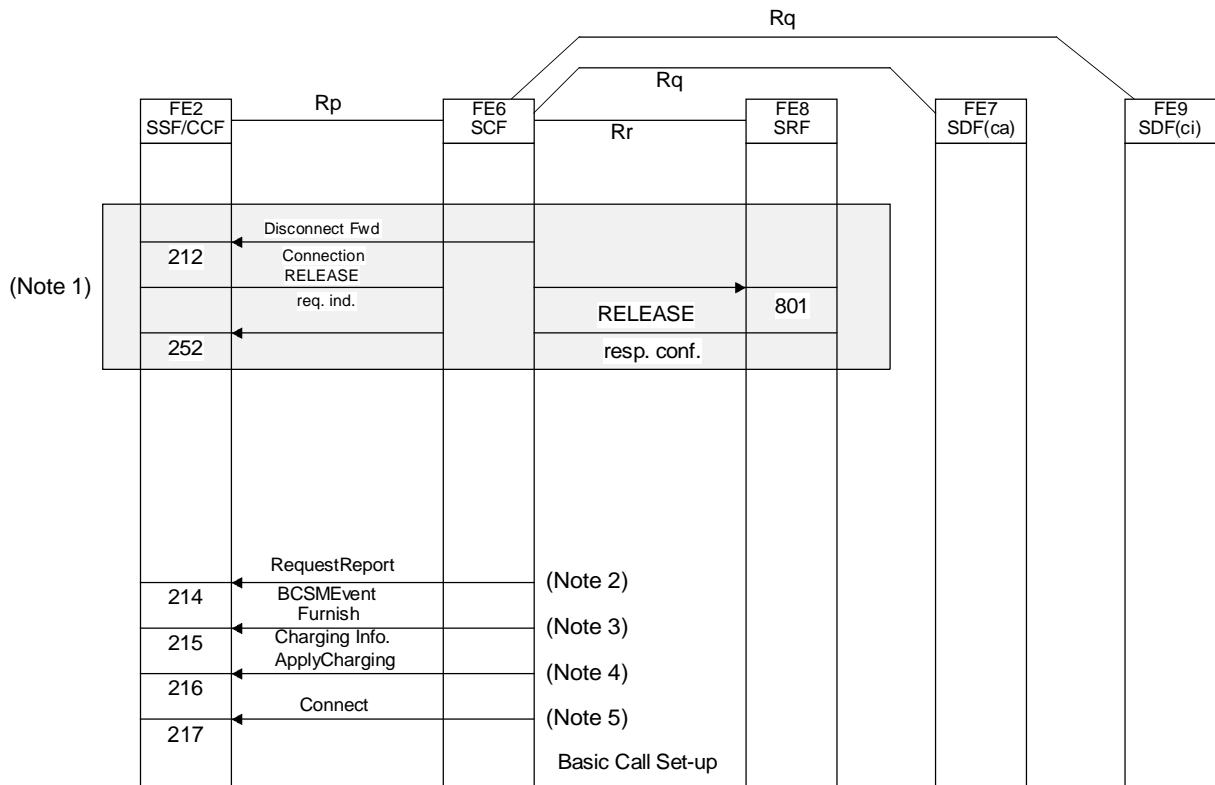

T1166320-94/d14

NOTES

- 1 The SRF is released (SCF initiated). If the follow-on procedure is foreseen the SRF may be not released.
- 2 Request Report BCSM Event req. ind. is used to arm Control Points (DPs) for Called disconnection and call set-up failure to allow follow-on.
- 3 Furnish charging operation (or other charging operation) for generation of billing record.
- 4 ApplyCharging operation to request information on call consuming.
- 5 Connect to destination number.

FIGURE IV.1/Q.86
Outgoing call set-up

Appendix V

Calling party abandon

(This appendix does not form an integral part of this Recommendation)

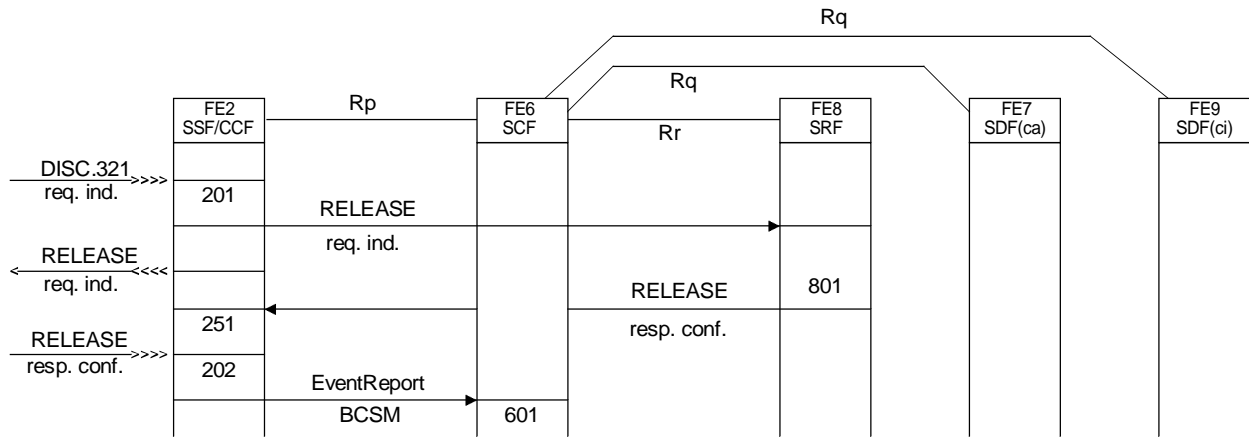

T1166330-94/d15

FIGURE V.1/Q.86

Calling party abandon

Appendix VI

Calling and called party initiated disconnection

(This appendix does not form an integral part of this Recommendation)

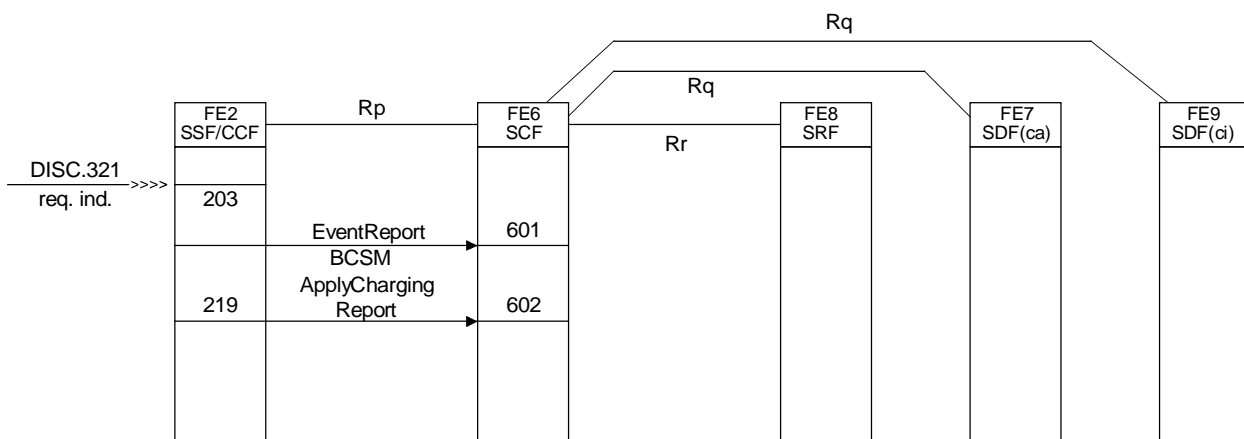

T1166340-94/d16

FIGURE VI.1/Q.86

Calling party initiated disconnection

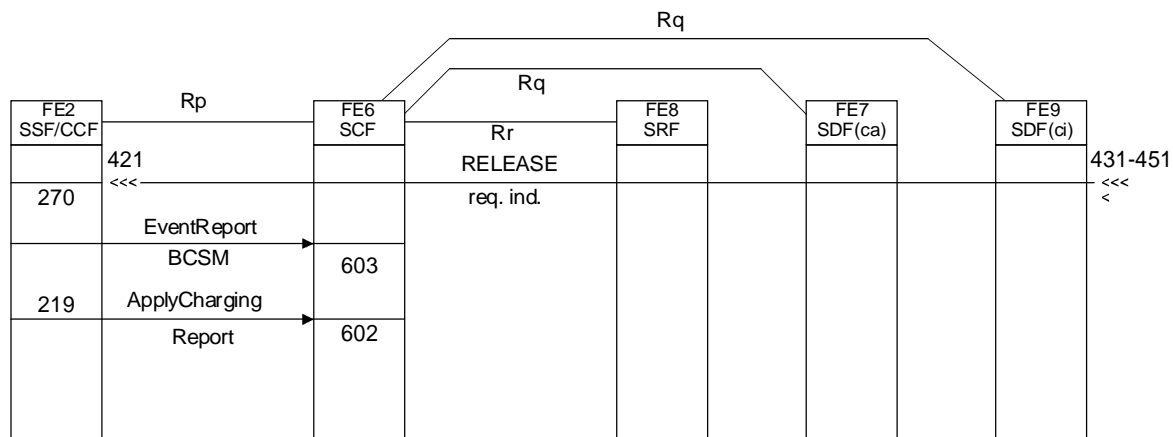

T1166350-94/d17

FIGURE VI.2/Q.86

Called party initiated disconnection

Appendix VII

Follow-on recognition

(This appendix does not form an integral part of this Recommendation)

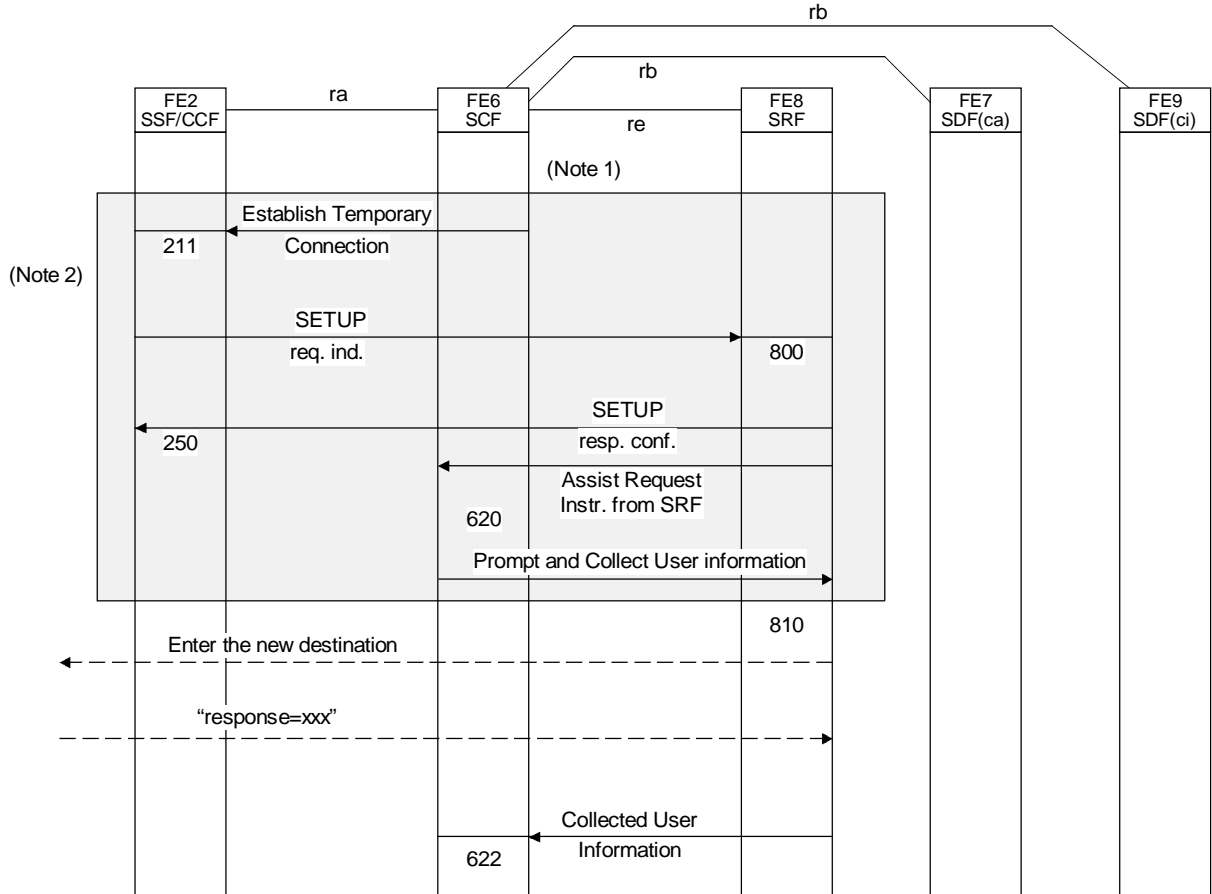

T1166360-94/d18

NOTES

- 1 See Note in Figure 4.
- 2 The order in which the SRF sends the SETUP resp. conf. and the Assist Request Instruction from SRF req. ind. is not significant. There are several SRF connection procedures, related to the physical location of the SRF. This example refers to the case in which there is a direct path between SCP and IP.

FIGURE VII.1/Q.86
Successful follow-on recognition

Appendix VIII

Network initiated disconnection

(This appendix does not form an integral part of this Recommendation)

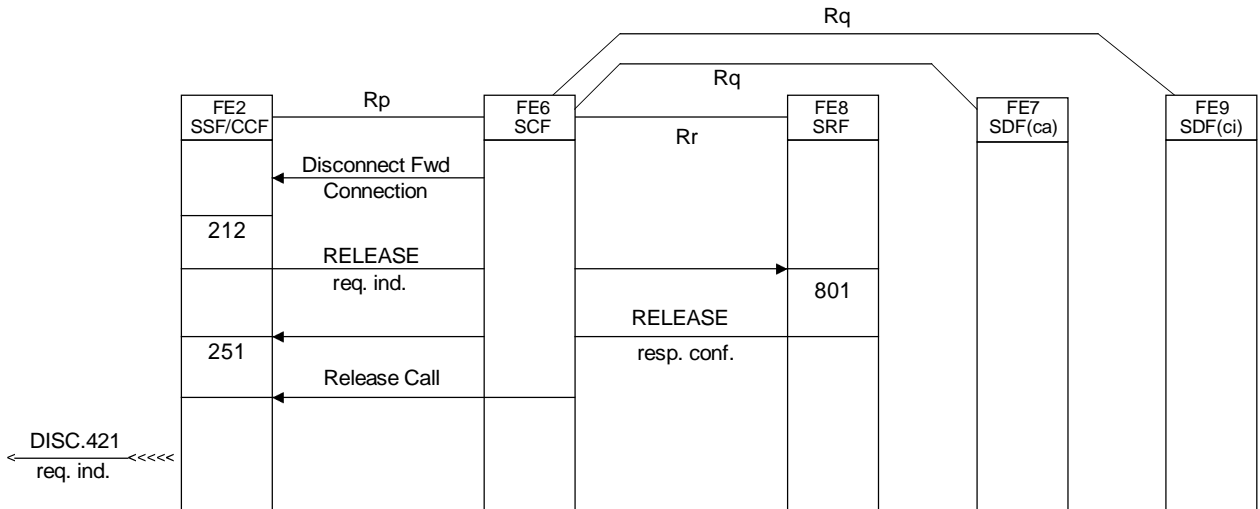

T1166370-94/d19

FIGURE VIII.1/Q.86

Network initiated disconnection