

Superseded by a more recent version



INTERNATIONAL TELECOMMUNICATION UNION

ITU-T

TELECOMMUNICATION
STANDARDIZATION SECTOR
OF ITU

Q.931

(03/93)

**DIGITAL SUBSCRIBER SIGNALLING SYSTEM No. 1
NETWORK LAYER**

**DIGITAL SUBSCRIBER SIGNALLING
SYSTEM No. 1 (DSS 1) – ISDN
USER-NETWORK INTERFACE LAYER 3
SPECIFICATION FOR BASIC CALL CONTROL**

ITU-T Recommendation Q.931

Superseded by a more recent version

(Previously “CCITT Recommendation”)

Superseded by a more recent version

FOREWORD

The ITU Telecommunication Standardization Sector (ITU-T) is a permanent organ of the International Telecommunication Union. The ITU-T is responsible for studying technical, operating and tariff questions and issuing Recommendations on them with a view to standardizing telecommunications on a worldwide basis.

The World Telecommunication Standardization Conference (WTSC), which meets every four years, established the topics for study by the ITU-T Study Groups which, in their turn, produce Recommendations on these topics.

ITU-T Recommendation Q.931 was revised by the ITU-T Study Group XI (1988-1993) and was approved by the WTSC (Helsinki, March 1-12, 1993).

NOTES

1 As a consequence of a reform process within the International Telecommunication Union (ITU), the CCITT ceased to exist as of 28 February 1993. In its place, the ITU Telecommunication Standardization Sector (ITU-T) was created as of 1 March 1993. Similarly, in this reform process, the CCIR and the IFRB have been replaced by the Radiocommunication Sector.

In order not to delay publication of this Recommendation, no change has been made in the text to references containing the acronyms "CCITT, CCIR or IFRB" or their associated entities such as Plenary Assembly, Secretariat, etc. Future editions of this Recommendation will contain the proper terminology related to the new ITU structure.

2 In this Recommendation, the expression "Administration" is used for conciseness to indicate both a telecommunication administration and a recognized operating agency.

© ITU 1994

All rights reserved. No part of this publication may be reproduced or utilized in any form or by any means, electronic or mechanical, including photocopying and microfilm, without permission in writing from the ITU.

Superseded by a more recent version

CONTENTS

	<i>Page</i>	
1	General	1
1.1	Scope of the Recommendation	1
1.2	Application to interface structures	1
2	Overview of call control.....	1
2.1	Circuit switched calls.....	2
2.2	Packet-mode access connections	4
2.3	Temporary signalling connections	6
2.4	States associated with the global call reference	8
3	Message functional definitions and content	9
3.1	Messages for circuit mode connection control	10
3.2	Messages for packet mode connection control	28
3.3	Messages for user signalling bearer service control	37
3.4	Messages with the global call reference	50
4	General message format and information elements coding.....	52
4.1	Overview	52
4.2	Protocol discriminator.....	53
4.3	Call reference.....	54
4.4	Message type	56
4.5	Other information elements	58
4.6	Information element for packet communications	116
5	Circuit-switched call control procedures.....	128
5.1	Call establishment at the originating interface.....	128
5.2	Call establishment at the destination interface.....	133
5.3	Call clearing.....	140
5.4	In-band tones and announcements.....	143
5.5	Restart procedure	143
5.6	Call rearrangements	145
5.7	Call collisions	148
5.8	Handling of error conditions.....	148
5.9	User notification procedure	154
5.10	Basic telecommunication service identification and selection.....	154
5.11	Signalling procedures for bearer capability selection.....	155
5.12	Signalling procedures for high layer compatibility selection	157
6	Packet communication procedures	159
6.1	Outgoing access	160
6.2	Incoming access.....	162
6.3	X.25 virtual call establishment and release.....	167
6.4	Call clearing.....	169
6.5	Access collision	173
7	User signalling bearer service call control procedures.....	173
7.1	General characteristics	173
7.2	Call establishment.....	174
7.3	Transfer of USER INFORMATION messages	175
7.4	Congestion control of USER INFORMATION messages	175
7.5	Call clearing.....	175

Superseded by a more recent version

	<i>Page</i>
8	Circuit-mode multirate (64 kbit/s base rate) procedures 175
8.1	Call establishment at the originating interface..... 176
8.2	Call establishment at the destination interface..... 177
8.3	Call clearing..... 179
8.4	Restart procedures 179
8.5	Call rearrangements 179
9	List of system parameters..... 179
9.1	Timers in the network side..... 179
9.2	Timers in the user side 179
Annex A	– User side and network side SDL diagrams 187
Annex B	– Compatibility and address checking..... 260
B.1	Introduction 260
B.2	Calling side compatibility checking..... 260
B.3	Called side compatibility and address checking 260
B.4	Interworking with existing networks 261
Annex C	– Transit network selection 263
C.1	Selection not supported..... 263
C.2	Selection supported..... 263
Annex D	– Extensions for symmetric call operation..... 264
D.1	Additional message handling..... 264
D.2	Timers for call establishment..... 265
D.3	Call collisions 265
Annex E	– Network specific facility selection 265
E.1	Default provider..... 265
E.2	Routing not supported..... 265
E.3	Routing supported..... 266
Annex F	– D-channel backup procedures 266
F.0	Foreword..... 266
F.1	General..... 266
F.2	D-channel backup procedure 267
Annex G	– Use of progress indicators..... 269
Annex H	– Message segmentation procedures..... 270
H.1	Introduction 270
H.2	Message segmentation 270
H.3	Reassembly of segmented messages..... 271
Annex I	– Low layer information coding principles 277
I.1	Purpose 277
I.2	Principles 277
I.3	Information classification 279
I.4	Scenarios outside the scope of ISDN standardization 282
Annex J	– Low layer compatibility negotiation 283
J.1	General..... 283
J.2	Low layer capability notification to the called user..... 284
J.3	Low layer compatibility negotiation between users 284
J.4	Low layer compatibility negotiation options 284
J.5	Alternate requested values 284
Annex K	– Procedures for establishment of bearer connection prior to call acceptance 285
K.1	General..... 285
K.2	Procedures 285
Annex L	– Optional procedures for bearer service change 286

Superseded by a more recent version

Page

Appendix I – Definition of causes values.....	287
Appendix II – Example message flow diagrams and example conditions for cause mapping.....	296
Appendix III – Summary of assigned information element identifier and message type code points for the Q.93x-Series and Q.95x-Series of Recommendations	309

Superseded by a more recent version

Recommendation Q.931

DIGITAL SUBSCRIBER SIGNALLING SYSTEM No. 1 (DSS 1) – ISDN USER-NETWORK INTERFACE LAYER 3 SPECIFICATION FOR BASIC CALL CONTROL

(Malaga-Torremolinos, 1984; modified at Helsinki, 1993)

1 General

This Recommendation specifies the procedures for the establishing, maintaining, and clearing of network connections at the ISDN user-network interface. These procedures are defined in terms of messages exchanged over the D-channel of basic and primary rate interface structures. The functions and procedures of this protocol, and the relationship with other layers, are described in general terms in Recommendation Q.930 (I.450) [1].

This Recommendation is intended to specify the essential features, procedures, and messages required for call control in the D-channel. However, there are some details of procedure which have not yet been specified, and which will be the subject of further study.

1.1 Scope of the Recommendation

The procedures currently described in this Recommendation are for the control of circuit-switched connections, user-to-user signalling connections, and packet-switched connections. The transport of other message-based information flows on the D-channel is a subject for further study and will be included in related Recommendations.

NOTES

1 The term “layer 3” is used for the functions and protocol described in this Recommendation [see Recommendation Q.930 (I.450)]. The terms “data link layer” and “layer 2” are used interchangeably to refer to the layer immediately below layer 3.

2 Alignment of the functions and protocol with those of OSI network layer is for further study.

1.2 Application to interface structures

The layer 3 procedures apply to the interface structures defined in Recommendation I.412 [2]. They use the functions and services provided by layer 2. The unacknowledged information transfer service is used by layer 3 to provide point-to-multipoint operation as described in 5.2.

The layer 3 procedures request the services of layer 2 and receive information from layer 2 using the primitives defined in Recommendation Q.921 [3]. These primitives are used to illustrate the communication between the protocol layers and are not intended to specify or constrain implementations.

2 Overview of call control

In this Recommendation the terms “incoming” and “outgoing” are used to describe the call as viewed by the user side of the interface.

In the subclauses which follow states are defined for circuit switched calls in 2.1 (call states), for packet mode access connections in 2.2 (access connection states) for temporary signalling connections in 2.3 (call states), and for the interface in 2.4 (global call reference states).

This clause defines the basic call control states that individual calls may have. These definitions do not apply to the state of the interface itself, any attached equipment, the D-channel, or the logical links used for signalling on the D-channel. Because several calls may exist simultaneously at a user-network interface, and each call may be in a different state, the state of the interface itself cannot be unambiguously defined.

NOTE – Additional states and SDL diagrams may be defined when new procedures are developed.

Superseded by a more recent version

A detailed description of the procedures for call control is given in clauses 5, 6, 7, and 8 in terms of:

- (a) the messages defined in clause 3 which are transferred across the user-network interface; and
- (b) the information processing and actions that take place at the userside and the network side.

Overview and detailed SDL diagrams for call control of circuit-switched calls are contained in Annex A.

Throughout this Recommendation, references are made to B-channels. For services using H-channels, the references to B-channels should be taken to refer to the appropriate H-channel. Further study may be needed on other enhancements to support such services.

2.1 Circuit switched calls

This subclause defines the basic call control states for circuit switched calls. The procedures for call control are given in clause 5.

Annex D contains optional procedures (as an extension to the basic procedures) to allow symmetric signalling. These states are defined in Annex D.

2.1.1 Call states at the user side of the interface

The states which may exist on the user side of the user-network interface are defined in this subclause.

2.1.1.1 Null state (U0)

No call exists.

2.1.1.2 Call initiated (U1)

This state exists for an outgoing call, when the user requests call establishment from the network.

2.1.1.3 Overlap sending (U2)

This state exists for an outgoing call when the user has received acknowledgement of the call establishment request which permits the user to send additional call information to the network in overlap mode.

2.1.1.4 Outgoing call proceeding (U3)

This state exists for an outgoing call when the user has received acknowledgement that the network has received all call information necessary to effect call establishment.

2.1.1.5 Call delivered (U4)

This state exists for an outgoing call, when the calling user has received an indication that remote user alerting has been initiated.

2.1.1.6 Call present (U6)

This state exists for an incoming call when the user has received a call establishment request but has not yet responded.

2.1.1.7 Call received (U7)

This state exists for an incoming call when the user has indicated alerting but has not yet answered.

2.1.1.8 Connect request (U8)

This state exists for an incoming call when the user has answered the call and is waiting to be awarded the call.

2.1.1.9 Incoming call proceeding (U9)

This state exists for an incoming call when the user has sent acknowledgement that the user has received all call information necessary to effect call establishment.

Superseded by a more recent version

2.1.1.10 Active (U10)

This state exists for an incoming call when the user has received an acknowledgement from the network that the user has been awarded the call. This state exists for an outgoing call when the user has received an indication that the remote user has answered the call.

2.1.1.11 Disconnect request (U11)

This state exists when the user has requested the network to clear the end-to-end connection (if any) and is waiting for a response.

2.1.1.12 Disconnect indication (U12)

This state exists when the user has received an invitation to disconnect because the network has disconnected the end-to-end connection (if any).

2.1.1.13 Suspend request (U15)

This state exists when the user has requested the network to suspend the call and is waiting for a response.

2.1.1.14 Resume request (U17)

This state exists when the user has requested the network to resume a previously suspended call and is waiting for a response.

2.1.1.15 Release request (U19)

This state exists when the user has requested the network to release and is waiting for a response.

2.1.1.16 Overlap receiving (U25)

This state exists for an incoming call when the user has acknowledged the call establishment request from the network and is prepared to receive additional call information (if any) in overlap mode.

2.1.2 Network call states

The call states that may exist on the network side of the user-network interface are defined in this subclause.

2.1.2.1 Null state (N0)

No call exists.

2.1.2.2 Call initiated (N1)

This state exists for an outgoing call when the network has received a call establishment request but has not yet responded.

2.1.2.3 Overlap sending (N2)

This state exists for an outgoing call when the network has acknowledged the call establishment request and is prepared to receive additional call information (if any) in overlap mode.

2.1.2.4 Outgoing call proceeding (N3)

This state exists for an outgoing call when the network has sent acknowledgement that the network has received all call information necessary to effect call establishment.

2.1.2.5 Call delivered (N4)

This state exists for an outgoing call when the network has indicated that remote user alerting has been initiated.

2.1.2.6 Call present (N6)

This state exists for an incoming call when the network has sent a call establishment request but has not yet received a satisfactory response.

Superseded by a more recent version

2.1.2.7 Call received (N7)

This state exists for an incoming call when the network has received an indication that the user is alerting but has not yet received an answer.

2.1.2.8 Connect request (N8)

This state exists for an incoming call when the network has received an answer but the network has not yet awarded the call.

2.1.2.9 Incoming call proceeding (N9)

This state exists for an incoming call when the network has received acknowledgement that the user has received all call information necessary to effect call establishment.

2.1.2.10 Active (N10)

This state exists for an incoming call when the network has awarded the call to the called user. This state exists for an outgoing call when the network has indicated that the remote user has answered the call.

2.1.2.11 Disconnect request (N11)

This state exists when the network has received a request from the user to clear the end-to-end connection (if any).

2.1.2.12 Disconnect indication (N12)

This state exists when the network has disconnected the end-to-end connection (if any) and has sent an invitation to disconnect the user-network connection.

2.1.2.13 Suspend request (N15)

This state exists when the network has received a request to suspend the call but has not yet responded.

2.1.2.14 Resume request (N17)

This state exists when the network has received a request to resume a previously suspended call but has not yet responded.

2.1.2.15 Release request (N19)

This state exists when the network has requested the user to release and is waiting for a response.

2.1.2.16 Call abort (N22)

This state exists for an incoming call for the point-to-multipoint configuration when the call is being cleared before any user has been awarded the call.

2.1.2.17 Overlap receiving (N25)

This state exists for an incoming call when the network has received acknowledgement of the call establishment request which permits the network to send additional call information (if any) in the overlap mode.

2.2 Packet-mode access connections

This subclause defines the basic packet-mode access connection control states for access to the ISDN virtual circuit bearer service (case B). The procedures for access connection control are given in clause 6.

2.2.1 Access connection states at the user side of the interface

The states which may exist on the user side of the user-network interface are defined in this subclause.

2.2.1.1 Null state (U0)

No access connection exists.

Superseded by a more recent version

2.2.1.2 Call initiated (U1)

This state exists for an outgoing access connection, when the user requests access connection establishment from the network.

2.2.1.3 Outgoing call proceeding (U3)

This state exists for an outgoing access connection when the user has received acknowledgement that the network has received all access connection information necessary to effect access connection establishment.

2.2.1.4 Call present (U6)

This state exists for an incoming access connection when the user has received an access connection establishment request but has not yet responded.

2.2.1.5 Call received (U7)

This state exists for an incoming access connection when the user has indicated alerting but has not yet answered.

2.2.1.6 Connect request (U8)

This state exists for an incoming access connection when the user has accepted the access connection and is waiting to be awarded the access connection.

2.2.1.7 Incoming call proceeding (U9)

This state exists for an incoming access connection when the user has sent acknowledgement that the user has received all access connection information necessary to effect access connection establishment.

2.2.1.8 Active (U10)

This state exists for an incoming access connection when the user has received an acknowledgement from the network that the user has been awarded the access connection. This state exists for an outgoing access connection when the user has received an indication that the local network has completed the access connection.

2.2.1.9 Disconnect request (U11)

This state exists when the user has requested the local network to clear the access connection and is waiting for a response.

2.2.1.10 Disconnect indication (U12)

This state exists when the user has received an invitation to disconnect because the network has disconnected the access connection to-end connection (if any).

2.2.1.11 Release request (U19)

This state exists when the user has requested the network to release the access connection and is waiting for a response.

2.2.2 Access connection states at the network side of the interface

The states which may exist on the network side of the user-network interface are defined in this subclause.

2.2.2.1 Null state (N0)

No access connection exists.

2.2.2.2 Call initiated (N1)

This state exists for an outgoing access connection when the network has received an access connection establishment request but has not yet responded.

2.2.2.3 Outgoing call proceeding (N3)

This state exists for an outgoing access connection when the network has sent acknowledgement that the network has received all access connection information necessary to effect access connection establishment.

Superseded by a more recent version

2.2.2.4 Call present (N6)

This state exists for an incoming access connection when the network has sent an access connection establishment request but has not yet received a satisfactory response.

2.2.2.5 Call received (N7)

This state exists for an incoming access connection when the network has received an indication that the user is alerting but has not yet received an answer.

2.2.2.6 Connect request (N8)

This state exists for an incoming access connection when the network has received an answer but the network has not yet awarded the access connection.

2.2.2.7 Incoming call proceeding (N9)

This state exists for an incoming access connection when the network has received acknowledgment that the user has received all access connection information necessary to effect access connection establishment.

2.2.2.8 Active (N10)

This state exists for an incoming access connection when the network has awarded the access connection to the called user. This state exists for an outgoing access connection when the local network has indicated that the access connection has been completed.

2.2.2.9 Disconnect request (N11)

This state exists when the network has received a request from the user to clear the access connection.

2.2.2.10 Disconnect indication (N12)

This state exists when the network has sent an invitation to disconnect the user-network access connection.

2.2.2.11 Release request (N19)

This state exists when the network has requested the user to release the access connection and is waiting for a response.

2.2.2.12 Call abort (N22)

This state exists for an incoming access connection for the point-to-multipoint configuration when the access connection is being cleared before any user has been awarded the access connection.

2.3 Temporary signalling connections

This subclause defines the basic call control states for user-to-user signalling not associated with circuit switched calls. The procedures for call control are given in 7.2.

2.3.1 Call states at the user side of the interface

The states which may exist on the user side of the user-network interface are defined in this subclause.

2.3.1.1 Null state (U0)

No call exists.

2.3.1.2 Call initiated (U1)

This state exists for an outgoing call, when the user requests call establishment from the network.

2.3.1.3 Overlap sending (U2)

This state exists for an outgoing call when the user has received acknowledgement of the call establishment request which permits the user to send additional call information to the network in overlap mode.

Superseded by a more recent version

2.3.1.4 Outgoing call proceeding (U3)

This state exists for an outgoing call when the user has received acknowledgement that the network has received all call information necessary to effect call establishment.

2.3.1.5 Call delivered (U4)

This state exists for an outgoing call, when the calling user has received an indication that remote user alerting has been initiated.

2.3.1.6 Call present (U6)

This state exists for an incoming call when the user has received a call establishment request but has not yet responded.

2.3.1.7 Call received (U7)

This state exists for an incoming call when the user has indicated alerting but has not yet answered.

2.3.1.8 Connect request (U8)

This state exists for an incoming call when the user has answered the call and is awaiting to be awarded the call.

2.3.1.9 Incoming call proceeding (U9)

This state exists for an incoming call when the user has sent acknowledgement that the user has received all call information necessary to effect call establishment.

2.3.1.10 Active (U10)

This state exists for an incoming call when the user has received an acknowledgement from the network that the user has been awarded the call. This state exists for an outgoing call when the user has received an indication that the remote user has answered the call.

2.3.1.11 Release request (U19)

This state exists when the user has requested the network to release and is waiting for a response.

2.3.1.12 Overlap receiving (U25)

This state exists for an incoming call when the user has acknowledged the call establishment request from the network and is prepared to receive additional call information (if any) in overlap mode.

2.3.2 Network call states

The call states that may exist on the network side of the user-network interface are defined in this subclause.

2.3.2.1 Null state (N0)

No call exists.

2.3.2.2 Call initiated (N1)

This state exists for an outgoing call when the network has received a call establishment request but has not yet responded.

2.3.2.3 Overlap sending (N2)

This state exists for an outgoing call when the network has acknowledged the call establishment request and is prepared to receive additional call information (if any) in overlap mode.

2.3.2.4 Outgoing call proceeding (N3)

This state exists for an outgoing call when the network has sent acknowledgement that the network has received all call information necessary to effect call establishment.

Superseded by a more recent version

2.3.2.5 Call delivered (N4)

This state exists for an outgoing call when the network has indicated that remote user alerting has been initiated.

2.3.2.6 Call present (N6)

This state exists for an incoming call when the network has sent a call establishment request but has not yet received a satisfactory response.

2.3.2.7 Call received (N7)

This state exists for an incoming call when the network has received an indication that the user is alerting but has not yet received an answer.

2.3.2.8 Connect request (N8)

This state exists for an incoming call when the network has received an answer but the network has not yet awarded the call.

2.3.2.9 Incoming call proceeding (N9)

This state exists for an incoming call when the network has received acknowledgement that the user has received all call information necessary to effect call establishment.

2.3.2.10 Active (N10)

This state exists for an incoming call when the network has awarded the call to the called user. This state exists for an outgoing call when the network has indicated that the remote user has answered the call.

2.3.2.11 Release request (N19)

This state exists when the network has requested the user to release and is waiting for a response.

2.3.2.12 Call abort (N22)

This state exists for an incoming call for the point-to-multipoint configuration when the call is being cleared before any user has been awarded the call.

2.3.2.13 Overlap receiving (N25)

This state exists for an incoming call when the network has received acknowledgement of the call establishment request which permits the network to send additional call information (if any) in the overlap mode.

2.4 States associated with the global call reference

This subclause defines the states that the protocol may adopt using the global call reference. The procedures for use of the global call reference for RESTART are contained in 5.5.

There is only one global call reference per interface.

2.4.1 Call states at the user side of the interface

The states which may exist on the user side of the user network interface are defined in this subclause.

2.4.1.1 Null (Rest 0)

No transaction exists.

2.4.1.2 Restart request (Rest 1)

This state exists for a restart transaction when the user has sent a restart request but has not yet received an acknowledgement response from the network.

Superseded by a more recent version

2.4.1.3 Restart (Rest 2)

This state exists when a request for a restart has been received from the network and responses have not yet been received from all locally active call references.

2.4.2 Call states at the network side of the interface

The states which may exist on the network side of the user-network interface are defined in this subclause.

2.4.2.1 Null (Rest 0)

No transaction exists.

2.4.2.2 Restart request (Rest 1)

This state exists for a restart transaction when the network has sent a restart request but has not yet received an acknowledgement response from the user.

2.4.2.3 Restart (Rest 2)

This state exists when a request for a restart has been received from the user and a response has not yet been received from all locally active call references.

3 Message functional definitions and content

This subclause provides an overview of the Q.931 message structure, which highlights the functional definition and information content (i.e. semantics) of each message. Each definition includes:

- a) A brief description of the message direction and use, including whether the message has:
 - 1) Local significance, i.e. relevant only in the originating or terminating access;
 - 2) Access significance, i.e. relevant in the originating and terminating access, but not in the network;
 - 3) Dual significance, i.e. relevant in either the originating or terminating access and in the network; or
 - 4) Global significance, i.e. relevant in the originating and terminating access and in the network.
- b) A table listing the codeset 0 information elements in the order of their appearance in the message (same relative order for all message types). For each information element the table indicates:
 - 1) the clause of this Recommendation describing the information element;
 - 2) the direction in which it may be sent; i.e. user to network (“u → n”), network to user (“n → u”), or both;

NOTE 1 – The user-network terminology in 3 refers to the TE-ET, TE-NT2, and NT2-ET interface structures. Annex D contains a description of the information element usage for symmetric NT2-NT2 interfaces.

- 3) whether inclusion is mandatory (“M”) or optional (“O”), with a reference to Notes explaining the circumstances under which the information element shall be included;
 - 4) the length of the information element (or permissible range of lengths), in octets, where “*” denotes an undefined maximum length, which may be network or service dependant;
- NOTE 2 – All messages may contain information elements from codesets 5, 6 and 7 and corresponding locking and non-locking shift information elements which comply with the coding rules specified in 4.5.2-4.5.4. None of these information elements, however, are listed in any of the tables in clause 3;
- c) further explanatory Notes, as necessary.

Superseded by a more recent version

3.1 Messages for circuit mode connection control

Table 3-1 summarizes the messages for circuit-mode connection control.

TABLE 3-1/Q.931

Messages for circuit-mode connection control

	Reference (subclauses)
<i>Call establishment messages:</i> ALERTING CALL PROCEEDING CONNECT CONNECT ACKNOWLEDGE PROGRESS SETUP SETUP ACKNOWLEDGE	3.1.1 3.1.2 3.1.3 3.1.4 3.1.8 3.1.14 3.1.15
<i>Call information phase messages:</i> RESUME RESUME ACKNOWLEDGE RESUME REJECT SUSPEND SUSPEND ACKNOWLEDGE SUSPEND REJECT	3.1.11 3.1.12 3.1.13 3.1.18 3.1.19 3.1.20
<i>Call clearing messages:</i> DISCONNECT RELEASE RELEASE COMPLETE	3.1.5 3.1.9 3.1.10
<i>Miscellaneous messages:</i> INFORMATION NOTIFY STATUS STATUS ENQUIRY	3.1.6 3.1.7 3.1.16 3.1.17
NOTE – In Recommendation Q.931 (1988) [53], support of user-user signalling was included for a number of reasons, including support of additional compatibility checking upon bilateral agreement with other users or in accordance with other standards (e.g. Recommendation X.213 [23]). To utilize this capability, the User-user information element can be included in the ALERTING, CONNECT, DISCONNECT, PROGRESS, RELEASE, RELEASE COMPLETE and SETUP messages. Details on this capability (explicit and implicit Type 1 user-user signalling) are given in Recommendation Q.957 [54].	

Superseded by a more recent version

3.1.1 ALERTING

This message is sent by the called user to the network and by the network to the calling user, to indicate that called user alerting has been initiated. See Table 3-2.

TABLE 3-2/Q.931

ALERTING message content

Message type: ALERTING Significance: global Direction: both				
Information element	Reference (subclause)	Direction	Type	Length
Protocol discriminator	4.2	Both	M	1
Call reference	4.3	Both	M	2-*
Message type	4.4	Both	M	1
Bearer capability	4.5	Both	O (Note 1)	4-12
Channel identification	4.5	Both (Note 2)	O (Note 3)	2-*
Progress indicator	4.5	Both	O (Note 4)	2-4
Display	4.5	n → u	O (Note 5)	(Note 6)
Signal	4.5	n → u	O (Note 7)	2-3
High layer compatibility	4.5	Both	O (Note 8)	2-5
NOTES 1 The Bearer capability information element is included when the procedures of 5.11 for bearer capability selection apply. When present, progress description No. 5, <i>interworking has occurred and has resulted in a telecommunication service change</i> shall also be present. 2 Included in the network to user direction for support of the procedures in Annex D. 3 Mandatory if this message is the first message in response to a SETUP, unless the user accepts the B-channel indicated in the SETUP message. 4 Included in the event of interworking. Included in the network-to-user direction in connection with the provision of in-band information/patterns. Included in the user-to-network direction in connection with the provision of in-band information/patterns if Annex K is implemented or in accordance with the procedures of 5.11.3 and 5.12.3. 5 Included if the network provides information that can be presented to the user. 6 The minimum length is 2 octets; the maximum length is network dependent and is either 34 or 82 octets. 7 Included if the network optionally provides information describing tones or alerting signals. 8 The High layer compatibility information element is included when the procedures of 5.12 for high layer compatibility selection apply. When present, progress description No. 5, <i>interworking has occurred and has resulted in a telecommunication service change</i> shall also be present.				

Superseded by a more recent version

3.1.2 CALL PROCEEDING

This message is sent by the called user to the network or by the network to the calling user to indicate that requested call establishment has been initiated and no more call establishment information will be accepted. See Table 3-3.

TABLE 3-3/Q.931

CALL PROCEEDING message content

Message type: CALL PROCEEDING Significance: local Direction: both				
Information element	Reference (subclause)	Direction	Type	Length
Protocol discriminator	4.2	Both	M	1
Call reference	4.3	Both	M	2-*
Message type	4.4	Both	M	1
Bearer capability	4.5	Both	O (Note 5)	4-12
Channel identification	4.5	Both	O (Note 1)	2-*
Progress indicator	4.5	Both	O (Note 2)	2-4
Display	4.5	n → u	O (Note 3)	(Note 4)
High layer compatibility	4.5	Both	O (Note 6)	2-5

NOTES

- 1 Mandatory in the network-to-user direction if this message is the first message in response to a SETUP message. It is mandatory in the user-to-network direction if this message is the first message in response to a SETUP message, unless the user accepts the B-channel indicated in the SETUP message.
- 2 Included in the event of interworking. Included in the network to user direction in connection with the provision of in-band information/patterns. Included in the user to network direction in connection with the provision of in-band information/patterns if Annex K is implemented or in accordance with the procedures of 5.11.3 and 5.12.3.
- 3 Included if the network provides information that can be presented to the user.
- 4 The minimum length is 2 octets; the maximum length is network dependent and is either 34 or 82 octets.
- 5 The Bearer capability information element is included when the procedures of 5.11 for bearer capability selection apply. When present, progress indication No. 5, *interworking has occurred and has resulted in a telecommunication service change* shall also be present.
- 6 The High layer compatibility information element is included when the procedures of 5.12 for high layer compatibility selection apply. When present, progress description No. 5, *interworking has occurred and has resulted in a telecommunication service change* shall also be present.

Superseded by a more recent version

3.1.3 CONNECT

This message is sent by the called user to the network and by the network to the calling user, to indicate call acceptance by the called user. See Table 3-4.

TABLE 3-4/Q.931

CONNECT message content

Message type: CONNECT Significance: global Direction: both				
Information element	Reference (subclause)	Direction	Type	Length
Protocol discriminator	4.2	Both	M	1
Call reference	4.3	Both	M	2-*
Message type	4.4	Both	M	1
Bearer capability	4.5	Both	O (Note 1)	4-12
Channel identification	4.5	Both (Note 2)	O (Note 3)	2-*
Progress indicator	4.4	Both	O (Note 4)	2-4
Display	4.5	n → u	O (Note 5)	(Note 6)
Date/time	4.5	n → u	O (Note 7)	8
Signal	4.5	n → u	O (Note 8)	2-3
Low layer compatibility	4.5	Both	O (Note 9)	2-18
High layer compatibility	4.5	Both	O (Note 10)	2-5
<p>NOTES</p> <p>1 The Bearer capability information element is included when the procedures of 5.11 for bearer capability selection apply.</p> <p>2 Included in the network-to-user direction for support of the procedures in Annex D.</p> <p>3 Mandatory if this is the first message in response to a SETUP, unless the user accepts the B-channel indicated in the SETUP message.</p> <p>4 Included in the event of interworking or in connection with the provision of in-band information/patterns.</p> <p>5 Included if the network provides information that can be presented to the user.</p> <p>6 The minimum length is 2 octets; the maximum length is network dependent and is either 34 or 82 octets.</p> <p>7 As a network option, may be included to provide date and time information to the calling user for all calls or for calls involving specific telecommunication services.</p> <p>8 Included if the network optionally provides additional information describing tones.</p> <p>9 Included in the user-to-network when the answering user wants to return low layer compatibility information to the calling user. Included in the network-to-user direction if the user awarded the call included a Low layer compatibility information element in the CONNECT message. Optionally included for low layer compatibility negotiation, but some networks may not transport this information element to the calling user (see Annex J).</p> <p>10 The High layer compatibility information element is included when the procedures of 5.12 for high layer compatibility selection apply.</p>				

Superseded by a more recent version

3.1.4 CONNECT ACKNOWLEDGE

This message is sent by the network to the called user to indicate the user has been awarded the call. It may also be sent by the calling user to the network to allow symmetrical call control procedures. See Table 3-5.

TABLE 3-5/Q.931

CONNECT ACKNOWLEDGE message content

Message type: CONNECT ACKNOWLEDGE Significance: local Direction: both				
Information element	Reference (subclause)	Direction	Type	Length
Protocol discriminator	4.2	Both	M	1
Call reference	4.3	Both	M	2-*
Message type	4.4	Both	M	1
Display	4.5	n → u	O (Note 1)	(Note 2)
Signal	4.5	n → u	O (Note 3)	2-3
NOTES				
1 Included if the network provides information that can be presented to the user.				
2 The minimum length is 2 octets; the maximum length is network dependent and is either 34 or 82 octets.				
3 Included if the network optionally provides additional information describing tones.				

Superseded by a more recent version

3.1.5 DISCONNECT

This message is sent by the user to request the network to clear an end-to-end connection or is sent by the network to indicate that the end-to-end connection is cleared. See Table 3-6.

TABLE 3-6/Q.931

DISCONNECT message content

Message type: DISCONNECT Significance: global Direction: both				
Information element	Reference (subclause)	Direction	Type	Length
Protocol discriminator	4.2	Both	M	1
Call reference	4.3	Both	M	2-*
Message type	4.4	Both	M	1
Cause	4.5	Both	M	4-32
Progress indicator	4.5	(Note 1)	O (Note 2)	2-4
Display	4.5	n → u	O (Note 3)	(Note 4)
Signal	4.5	n → u	O (Note 5)	2-3
NOTES				
1 Included in the network-to-user direction if the network provides in-band tones. See Annex D for usage in the user-to-network direction.				
2 Included by the network if in-band tones are provided. However, the user may include the progress indicator and provide in-band tones. See Annex D. In such cases the network will ignore this information element and will not convey the in-band tones.				
3 Included if the network provides information that can be presented to the user.				
4 The minimum length is 2 octets; the maximum length is network dependent and is either 34 or 82 octets.				
5 Included if the network optionally provides additional information describing tones.				

Superseded by a more recent version

3.1.6 INFORMATION

This message is sent by the user or the network to provide additional information. It may be used to provide information for call establishment (e.g. overlap sending) or miscellaneous call-related information. See Table 3-7.

TABLE 3-7/Q.931

INFORMATION message content

Message type: INFORMATION Significance: local (Note 1) Direction: both				
Information element	Reference (subclause)	Direction	Type	Length
Protocol discriminator	4.2	Both	M	1
Call reference	4.3	Both	M (Note 2)	2-*
Message type	4.4	Both	M	1
Sending complete	4.5	Both	O (Note 3)	1
Display	4.5	n → u	O (Note 4)	(Note 5)
Keypad facility	4.5	u → n	O (Note 6)	2-34
Signal	4.5	n → u	O (Note 7)	2-3
Called party number	4.5	u → n	O (Note 8)	2-*
NOTES 1 This message has local significance, but may carry information of global significance. 2 This message may be sent with the dummy call reference defined in 4.3 when feature key management procedures are used (see Recommendation Q.932); otherwise the minimum length is 2 octets. 3 Included if the user optionally indicates completion of overlap sending to the network, or if the network optionally indicates completion of overlap receiving to the user. 4 Included if the network provides information that can be presented to the user. 5 The minimum length is 2 octets; the maximum length is network dependent and is either 34 or 82 octets. 6 Either the Called party number or the Keypad facility information element is included by the user to transfer called party number information to the network during overlap sending. The Keypad facility information element may also be included if the user wants to convey other call establishment information to the network, or to convey supplementary service information. 7 Included if the network optionally provides additional information describing tones. 8 Either the Called party number or the Keypad facility information element is included by the user to convey called party number information to the network during overlap sending. The Called party number information element is included by the network to convey called party number information to the user during overlap receiving.				

Superseded by a more recent version

3.1.7 NOTIFY

This message is sent by the user or the network to indicate information pertaining to a call, such as user suspended. See Table 3-8.

TABLE 3-8/Q.931

NOTIFY message content

Message type: NOTIFY Significance: access Direction: both				
Information element	Reference (subclause)	Direction	Type	Length
Protocol discriminator	4.2	Both	M	1
Call reference	4.3	Both	M	2-*
Message type	4.4	Both	M	1
Bearer capability	4.5	n → u	O (Note 1)	2-12
Notification indicator	4.5	Both	M	3
Display	4.5	n → u	O (Note 2)	(Note 3)
NOTES				
1 Included by the network to indicate a change of the bearer capability (see Annex L).				
2 Included if the network provides information that can be presented to the user.				
3 The minimum length is 2 octets; the maximum length is network dependent and is either 34 or 82 octets.				

Superseded by a more recent version

3.1.8 PROGRESS

This message is sent by the user or the network to indicate the progress of a call in the event of interworking or in relation with the provision of in-band information/patterns. See Table 3-9.

TABLE 3-9/Q.931

PROGRESS message content

Message type: PROGRESS Significance: global Direction: both				
Information element	Reference (subclause)	Direction	Type	Length
Protocol discriminator	4.2	Both	M	1
Call reference	4.3	Both	M	2-*
Message type	4.4	Both	M	1
Bearer capability	4.5	Both	O (Note 1)	4-12
Cause	4.5	Both	O (Note 2)	2-32
Progress indicator	4.5	Both	M	4
Display	4.5	n → u	O (Note 3)	(Note 4)
High layer compatibility	4.5	Both	O (Note 5)	2-5
<p>NOTES</p> <p>1 The Bearer capability information element is included when the procedures of 5.11 for bearer capability selection apply. The Bearer capability information element indicates the bearer service now being used for the call.</p> <p>2 Included by the user or the network to provide additional information concerning the provision of in-band information/patterns.</p> <p>3 Included if the network provides information that can be presented to the user.</p> <p>4 The minimum length is 2 octets; the maximum length is network dependent and is either 34 or 82 octets.</p> <p>5 The High layer compatibility information element is included when the optional procedures of 5.12 for high layer compatibility selection apply. The High layer compatibility information element indicates the high layer compatibility now being used for the call.</p>				

Superseded by a more recent version

3.1.9 RELEASE

This message is sent by the user or the network to indicate that the equipment sending the message has disconnected the channel (if any) and intends to release the channel and the call reference. Thus the receiving equipment should release the channel and prepare to release the call reference after sending a RELEASE COMPLETE. See Table 3-10.

TABLE 3-10/Q.931

RELEASE message content

Message type: RELEASE Significance: local (Note 1) Direction: both				
Information element	Reference (subclause)	Direction	Type	Length
Protocol discriminator	4.2	Both	M	1
Call reference	4.3	Both	M	2-*
Message type	4.4	Both	M	1
Cause	4.5	Both	O (Note 2)	2-32
Display	4.5	n → u	O (Note 3)	(Note 4)
Signal	4.5	n → u	O (Note 5)	2-3
NOTES				
1 This message has local significance; however, it may carry information of global significance when used as the first call clearing message.				
2 Mandatory in the first call clearing message, including when the RELEASE message is sent as a result of an error handling condition.				
3 Included if the network provides information that can be presented to the user.				
4 The minimum length is 2 octets; the maximum length is network dependent and is either 34 or 82 octets.				
5 Included if the network optionally provides additional information describing tones.				

3.1.10 RELEASE COMPLETE

This message is sent by the user or the network to indicate that the equipment sending the message has released the channel (if any) and call reference, the channel is available for reuse, and the receiving equipment shall release the call reference. See Table 3-11.

Superseded by a more recent version

TABLE 3-11/Q.931

RELEASE COMPLETE message content

Message type: RELEASE COMPLETE Significance: local (Note 1) Direction: both				
Information element	Reference (subclause)	Direction	Type	Length
Protocol discriminator	4.2	Both	M	1
Call reference	4.3	Both	M	2-*
Message type	4.4	Both	M	1
Cause	4.5	Both	O (Note 2)	2-32
Display	4.5	n → u	O (Note 3)	(Note 4)
Signal	4.5	n → u	O (Note 5)	2-3
NOTES 1 This message has local significance; however, it may carry information of global significance when used as the first call clearing message. 2 Mandatory in the first call clearing message, including when the RELEASE COMPLETE message is sent as a result of an error handling condition. 3 Included if the network provides information that can be presented to the user. 4 The minimum length is 2 octets; the maximum length is network dependent and is either 34 or 82 octets. 5 Included if the network optionally provides additional information describing tones.				

3.1.11 RESUME

This message is sent by the user to request the network to resume a suspended call. See Table 3-12.

TABLE 3-12/Q.931

RESUME message content

Message type: RESUME Significance: local Direction: user to network				
Information element	Reference (subclause)	Direction	Type	Length
Protocol discriminator	4.2	u → n	M	1
Call reference	4.3	u → n	M	2-*
Message type	4.4	u → n	M	1
Call identity	4.5	u → n	O (Note 2)	2-10
NOTE – Included when the SUSPEND message used to suspend the call included a Call identity information element.				

Superseded by a more recent version

3.1.12 RESUME ACKNOWLEDGE

This message is sent by the network to the user to indicate completion of a request to resume a suspended call. See Table 3-13.

TABLE 3-13/Q.931

RESUME ACKNOWLEDGE message content

Message type: RESUME ACKNOWLEDGE Significance: local Direction: network to user				
Information element	Reference (subclause)	Direction	Type	Length
Protocol discriminator	4.2	n → u	M	1
Call reference	4.3	n → u	M	2-*
Message type	4.4	n → u	M	1
Channel identification	4.5	n → u	M	3-*
Display	4.5	n → u	O (Note 1)	(Note 2)
NOTES 1 Included if the network provides information that can be presented to the user. 2 The minimum length is 2 octets; the maximum length is network dependent and is either 34 or 82 octets.				

3.1.13 RESUME REJECT

This message is sent by the network to the user to indicate failure of a request to resume a suspended call. See Table 3-14.

TABLE 3-14/Q.931

RESUME REJECT message content

Message type: RESUME REJECT Significance: local Direction: network to user				
Information element	Reference (subclause)	Direction	Type	Length
Protocol discriminator	4.2	n → u	M	1
Call reference	4.3	n → u	M	2-*
Message type	4.4	n → u	M	1
Cause	4.5	n → u	M	4-32
Display	4.5	n → u	O (Note 1)	(Note 2)
NOTES 1 Included if the network provides information that can be presented to the user. 2 The minimum length is 2 octets; the maximum length is network dependent and is either 34 or 82 octets.				

Superseded by a more recent version

3.1.14 SETUP

This message is sent by the calling user to the network and by the network to the called user to initiate call establishment. See Table 3-15.

TABLE 3-15/Q.931

SETUP message content

Message type: SETUP Significance: global Direction: both				
Information element	Reference (subclause)	Direction	Type	Length
Protocol discriminator	4.2	Both	M	1
Call reference	4.3	Both	M	2-*
Message type	4.4	Both	M	1
Sending complete	4.5	Both	O (Note 1)	1
Repeat indicator	4.5	Both	O (Note 2)	1
Bearer capability	4.5	Both	M (Note 3)	4-12
Channel identification	4.5	Both	O (Note 4)	2-*
Progress indicator	4.5	Both	O (Note 5)	2-4
Network specific facilities	4.5	Both	O (Note 6)	2-*
Display	4.5	n → u	O (Note 7)	(Note 8)
Keypad facility	4.5	u → n	O (Note 9)	2-34
Signal	4.5	n → u	O (Note 10)	2-3
Calling party number	4.5	Both	O (Note 11)	2-*
Calling party subaddress	4.5	Both	O (Note 12)	2-23
Called party number	4.5	Both	O (Note 13)	2-*
Called party subaddress	4.5	Both	O (Note 14)	2-23
Transit network selection	4.5	u → n	O (Note 15)	2-*
Repeat indicator	4.5	Both	O (Note 16)	1
Low layer compatibility	4.5	Both	O (Note 17)	2-18
High layer compatibility	4.5	Both	O (Note 18)	2-5

Superseded by a more recent version

NOTES

- 1 Included if the user or the network optionally indicates that all information necessary for call establishment is included in the SETUP message.
- 2 The Repeat indicator information element is included immediately before the first Bearer capability information element when the bearer capability negotiation procedure is used (see Annex L).
- 3 May be repeated if the bearer capability negotiation procedure is used (see Annex L). For bearer capability negotiation, two Bearer capability information elements may be included in descending order of priority, i.e., highest priority first. Although support of multiple Bearer capability information elements may not be supported on all networks, on networks that do support it, and through suitable subscription arrangements, two Bearer capability information elements may be included (see 5.11). When they are not preceded by a Repeat indicator information element, they are included in ascending order of priority.
- 4 Mandatory in the network-to-user direction. Included in the user-to-network direction when a user wants to indicate a channel. If not included, its absence is interpreted as “any channel acceptable”.
- 5 Included in the event of interworking or in connection with the provision of in-band information/patterns.
- 6 Included by the calling user or the network to indicate network specific facilities information (see Annex E).
- 7 Included if the network provides information that can be presented to the user.
- 8 The minimum length is 2 octets; the maximum length is network dependent and is either 34 or 82 octets.
- 9 Either the Called party number or the Keypad facility information element is included by the user to convey called party number information to the network. The Keypad facility information element may also be included by the user to convey other call establishment information to the network.
- 10 Included if the network optionally provides additional information describing tones.
- 11 May be included by the calling user or the network to identify the calling user. Not included in the network-to-user direction for basic call control, but may be included for some supplementary services.
- 12 Included in the user-to-network direction when the calling user wants to indicate the calling party subaddress. Not included in the network-to-user direction for basic call control, but may be included for some supplementary services.
- 13 Either the Called party number or the Keypad facility information element is included by the user to convey called party number information to the network. The Called party number information element is included by the network when called party number information is to be conveyed to the user.
- 14 Included in the user-to-network direction when the calling user wants to indicate the called party subaddress. Included in the network-to-user direction if the calling user included a Called party subaddress information element in the SETUP message.
- 15 Included by the calling user to select a particular transit network (see Annex C).
- 16 Included when two or more Low layer compatibility information elements are included for low layer compatibility negotiation.
- 17 Included in the user-to-network direction when the calling user wants to pass low layer compatibility information to the called user. Included in the network-to-user direction if the calling user included a Low layer compatibility information element in the SETUP message. Two, three or four information elements may be included in descending order of priority, i.e. highest priority first, if the low layer compatibility negotiation procedures are used (see Annex J).
- 18 Included in the user-to-network direction when the calling user wants to pass high layer compatibility information to the called user. Included in the network-to-user direction if the calling user included a High layer compatibility information element in the SETUP message. Although support of multiple High layer compatibility information elements may not be supported on all networks, on networks that do support it, and through suitable subscription arrangements, two High layer compatibility information elements may be included (see 5.12). When they are not preceded by a Repeat indicator information element, they are included in ascending order of priority.

Superseded by a more recent version

3.1.15 SETUP ACKNOWLEDGE

This message is sent by the network to the calling user, or by the called user to the network, to indicate that call establishment has been initiated, but additional information may be required. See Table 3-16.

TABLE 3-16/Q.931

SETUP ACKNOWLEDGE message content

Message type: SETUP ACKNOWLEDGE Significance: local Direction: both				
Information element	Reference (subclause)	Direction	Type	Length
Protocol discriminator	4.2	Both	M	1
Call reference	4.3	Both	M	2-*
Message type	4.4	Both	M	1
Channel identification	4.5	Both	O (Note 1)	2-*
Progress indicator	4.5	Both	O (Note 2)	2-4
Display	4.5	n → u	O (Note 3)	(Note 4)
Signal	4.5	n → u	O (Note 5)	2-3
NOTES 1 Mandatory in all cases, except when the user accepts the specific B-channel indicated in the SETUP message. 2 Included in the event of interworking or in connection with the provision of in-band information/patterns. 3 Included if the network provides information that can be presented to the user. 4 The minimum length is 2 octets; the maximum length is network dependent and is either 34 or 82 octets. 5 Included if the network optionally provides information describing tones (e.g. activate dial tone).				

Superseded by a more recent version

3.1.16 STATUS

This message sent is by the user or the network in response to a STATUS ENQUIRY message or at any time during a call to report certain error conditions listed in 5.8. See Table 3-17.

TABLE 3-17/Q.931

STATUS message content

Message type: STATUS Significance: local Direction: both				
Information element	Reference (subclause)	Direction	Type	Length
Protocol discriminator	4.2	Both	M	1
Call reference	4.3	Both	M	2-*
Message type	4.4	Both	M	1
Cause	4.5	Both	M	4-32
Call state	4.5	Both	M	3
Display	4.5	n → u	O (Note 1)	(Note 2)
NOTES				
1 Included if the network provides information that can be presented to the user.				
2 The minimum length is 2 octets; the maximum length is network dependent and is either 34 or 82 octets.				

Superseded by a more recent version

3.1.17 STATUS ENQUIRY

The STATUS ENQUIRY message is sent by the user or the network at any time to solicit a STATUS message from the peer layer 3 entity. Sending a STATUS message in response to a STATUS ENQUIRY message is mandatory. See Table 3-18.

TABLE 3-18/Q.931

STATUS ENQUIRY message content

Message type: STATUS ENQUIRY Significance: local Direction: both				
Information element	Reference (subclause)	Direction	Type	Length
Protocol discriminator	4.2	Both	M	1
Call reference	4.3	Both	M	2-*
Message type	4.4	Both	M	1
Display	4.5	n → u	O (Note 1)	(Note 2)
NOTES				
1 Included if the network provides information that can be presented to the user.				
2 The minimum length is 2 octets; the maximum length is network dependent and is either 34 or 82 octets.				

3.1.18 SUSPEND

This message is sent by the user to request the network to suspend a call. See Table 3-19.

TABLE 3-19/Q.931

SUSPEND message content

Message type: SUSPEND Significance: local Direction: user to network				
Information element	Reference (subclause)	Direction	Type	Length
Protocol discriminator	4.2	u → n	M	1
Call reference	4.3	u → n	M	2-*
Message type	4.4	u → n	M	1
Call identity	4.5	u → n	O (Note)	2-10
NOTE – Included if the user wants to identify the suspended call explicitly.				

Superseded by a more recent version

3.1.19 SUSPEND ACKNOWLEDGE

This message is sent by the network to the user to indicate completion of a request to suspend a call. See Table 3-20.

TABLE 3-20/Q.931

SUSPEND ACKNOWLEDGE message content

Message type: SUSPEND ACKNOWLEDGE Significance: local Direction: network to user				
Information element	Reference (subclause)	Direction	Type	Length
Protocol discriminator	4.2	n → u	M	1
Call reference	4.3	n → u	M	2*
Message type	4.4	n → u	M	1
Display	4.5	n → u	O (Note 1)	(Note 2)
NOTES				
1 Included if the network provides information that can be presented to the user.				
2 The minimum length is 2 octets; the maximum length is network dependent and is either 34 or 82 octets.				

3.1.20 SUSPEND REJECT

This message is sent by the network to the user to indicate failure of a request to suspend a call. See Table 3-21.

TABLE 3-21/Q.931

SUSPEND REJECT message content

Message type: SUSPEND REJECT Significance: local Direction: network to user				
Information element	Reference (subclause)	Direction	Type	Length
Protocol discriminator	4.2	n → u	M	1
Call reference	4.3	n → u	M	2-*
Message type	4.4	n → u	M	1
Cause	4.5	n → u	M	4-32
Display	4.5	n → u	O (Note 1)	(Note 2)
NOTES				
1 Included if the network provides information that can be presented to the user.				
2 The minimum length is 2 octets; the maximum length is network dependent and is either 34 or 82 octets.				

Superseded by a more recent version

3.2 Messages for packet mode connection control

Table 3-22 summarizes the messages for packet-mode access connection control. The message tables in this subclause should be used for Case B (packet switched access to an ISDN virtual circuit service) as defined in clause 6. For Case A (circuit switched access to PSPDN services) the message tables in 3.1 should be used.

TABLE 3-22/Q.931

Messages for packet-mode access connection control

	Reference (subclause)
<i>Access connection establishment messages:</i>	
ALERTING	3.2.1
CALL PROCEEDING	3.2.2
CONNECT	3.2.3
CONNECT ACKNOWLEDGE	3.2.4
PROGRESS	3.2.6
SETUP	3.2.9
<i>Access connection clearing messages:</i>	
DISCONNECT	3.2.5
RELEASE	3.2.7
RELEASE COMPLETE	3.2.8
<i>Miscellaneous messages:</i>	
STATUS	3.2.10
STATUS ENQUIRY	3.2.11

3.2.1 ALERTING

This message is sent by the called user to the network to indicate that called user alerting has been initiated. See Table 3-23.

TABLE 3-23/Q.931

ALERTING message content

Message type: ALERTING Significance: local Direction: user to network				
Information element	Reference (subclause)	Direction	Type	Length
Protocol discriminator	4.2	u → n	M	1
Call reference	4.3	u → n	M	2-*
Message type	4.4	u → n	M	1
Channel identification	4.5	u → n	O (Note 1)	2-*
Progress indicator	4.5	u → n	O (Note 2)	2-4
NOTES 1 Mandatory if this message is the first message in response to SETUP, unless the user accepts the channel indicated in the SETUP message. 2 Included in the event of interworking within a private network.				

Superseded by a more recent version

3.2.2 CALL PROCEEDING

This message is sent by the called user or by the network to the calling user to indicate that requested access connection establishment has been initiated. See Table 3-24.

TABLE 3-24/Q.931

CALL PROCEEDING message content

Message type: CALL PROCEEDING Significance: local Direction: both				
Information element	Reference (subclause)	Direction	Type	Length
Protocol discriminator	4.2	Both	M	1
Call reference	4.3	Both	M	2-*
Message type	4.4	Both	M	1
Channel identification	4.5	Both	O (Note 1)	2-*
Progress indicator	4.5	u → n	O (Note 2)	2-4
Display	4.5	n → u	O (Note 3)	(Note 4)

NOTES

- 1 Mandatory in the network-to-user direction if this message is the first message in response to a SETUP. Mandatory in the user-to-network direction if this message is the first message in response to SETUP message, unless the user accepts the channel indicated in the SETUP message.
- 2 Included in the event of interworking. Included in the network-to-user direction in connection with the provision of in-band information/patterns. Included in the user-to-network direction in connection with in-band information/patterns if Annex K is implemented or in accordance with the procedures of 5.11.3 and 5.12.3.
- 3 Included if the network provides information that can be presented to the user.
- 4 The minimum length is 2 octets; the maximum length is network dependent and is either 34 or 82 octets.

Superseded by a more recent version

3.2.3 CONNECT

This message is sent by the called user to the network, and by the network to the calling user, to indicate acceptance of the access connection. See Table 3-25.

TABLE 3-25/Q.931

CONNECT message content

Message type: CONNECT Significance: global Direction: both				
Information element	Reference (subclause)	Direction	Type	Length
Protocol discriminator	4.2	Both	M	1
Call reference	4.3	Both	M	2-*
Message type	4.4	Both	M	1
Channel identification	4.5	u → n	O (Note 1)	2-*
Progress indicator	4.5	u → n	O (Note 4)	2-4
Display	4.5	n → u	O (Note 2)	(Note 3)
NOTES 1 Mandatory if this message is the first message in response to SETUP, unless the user accepts the channel indicated in the SETUP message. 2 Included in the network provides information that can be presented to the user. 3 The minimum length is 2 octets; the maximum length is network dependent and is either 34 or 82 octets. 4 Included in the event of interworking within a private network.				

3.2.4 CONNECT ACKNOWLEDGE

This message is sent by the network to the called user to indicate that the user has been awarded the access connection. It may also be sent by the calling user to the network to allow symmetrical access connection control procedures. See Table 3-26.

TABLE 3-26/Q.931

CONNECT ACKNOWLEDGE message content

Message type: CONNECT ACKNOWLEDGE Significance: local Direction: both				
Information element	Reference (subclause)	Direction	Type	Length
Protocol discriminator	4.2	Both	M	1
Call reference	4.3	Both	M	2-*
Message type	4.4	Both	M	1
Display	4.5	n → u	O (Note 1)	(Note 2)
NOTES 1 Included if the network provides information that can be presented to the user. 2 The minimum length is 2 octets; the maximum length is network dependent and is either 34 or 82 octets.				

Superseded by a more recent version

3.2.5 DISCONNECT

This message is sent by the user to request the network to clear an access connection or is sent by the network to the user to indicate clearing of the access connection. See Table 3-27.

TABLE 3-27/Q.931

DISCONNECT message contents

Message type: DISCONNECT Significance: local Direction: both				
Information element	Reference (subclause)	Direction	Type	Length
Protocol discriminator	4.2	Both	M	1
Call reference	4.3	Both	M	2-*
Message type	4.4	Both	M	1
Cause	4.5	Both	M	4-32
Display	4.5	n → u	O (Note 1)	(Note 2)
User-user	4.5	u → n	O (Note 3)	(Note 4)
NOTES 1 Included if the network provides information that can be presented to the user. 2 The minimum length is 2 octets; the maximum length is network dependent and is either 34 or 82 octets. 3 May be sent if the access connection has not yet reached the active state. However, user-user information is not sent after the access connection has reached the active state since X.25 procedures would be used for this information transfer. 4 The minimum length is 2 octets; the standard default maximum length is 131 octets.				

3.2.6 PROGRESS

This message is sent by the called user or the network to indicate the progress of an access connection establishment in the event of interworking within a private network. See Table 3-28.

TABLE 3-28/Q.931

PROGRESS message content

Message type: PROGRESS Significance: local Direction: user to network				
Information element	Reference (subclause)	Direction	Type	Length
Protocol discriminator	4.2	u → n	M	1
Call reference	4.3	u → n	M	2-*
Message type	4.4	u → n	M	1
Cause	4.5	u → n	O (Note)	2-32
Progress indicator	4.5	u → n	M	4
NOTE – Included by the called user to provide additional information.				

Superseded by a more recent version

3.2.7 RELEASE

This message is sent by the user or the network to indicate that the equipment sending the message has disconnected the channel (if any) and intends to release the channel and the call reference, and that the receiving equipment should release the channel and prepare to release the call reference after sending RELEASE COMPLETE. The RELEASE message is sent by the network to the user to indicate that the access connection is awarded on either the D-channel or an existing channel and that the network intends to release the call reference. See Table 3-29.

TABLE 3-29/Q.931

RELEASE message content

Message type: RELEASE Significance: local (Note 1) Direction: both				
Information element	Reference (subclause)	Direction	Type	Length
Protocol discriminator	4.2	Both	M	1
Call reference	4.3	Both	M	2-*
Message type	4.4	Both	M	1
Cause	4.5	Both	O (Note 2)	2-32
Display	4.5	n → u	O (Note 3)	(Note 4)
User-user	4.5	u → n	O (Note 5)	(Note 6)

NOTES

- 1 This message has local significance; however, it may carry information of global significance when used as the first call clearing message.
- 2 Mandatory in the first clearing message, including when the RELEASE message is sent as a result of an error handling condition.
- 3 Included if the network provides information that can be presented to the user.
- 4 The minimum length is 2 octets; the maximum length is network dependent and is either 34 or 82 octets.
- 5 User-user information may be sent if RELEASE is the first clearing message and the access connection has not yet reached the active state and Q.931/X.25 mapping service is provided by the network. However, user-user information is not sent if the access connection has reached the active state since X.25 procedures would be used for this information transfer.
- 6 The minimum length is 2 octets; the standard default maximum length is 131 octets.

Superseded by a more recent version

3.2.8 RELEASE COMPLETE

This message is sent by the user or the network to indicate that the equipment sending the message has released the channel (if any) and call reference. The channel is available for reuse, and the receiving equipment shall release the call reference. See Table 3-30.

TABLE 3-30/Q.931

RELEASE COMPLETE message content

Message type: RELEASE COMPLETE Significance: local (Note 1) Direction: both				
Information element	Reference (subclause)	Direction	Type	Length
Protocol discriminator	4.2	Both	M	1
Call reference	4.3	Both	M	2-*
Message type	4.4	Both	M	1
Cause	4.5	Both	O (Note 2)	2-32
Display	4.5	n → u	O (Note 3)	(Note 4)
User-user	4.5	u → n	O (Note 5)	(Note 6)

NOTES

- 1 This message has local significance; however, it may carry information of global significance when used as the first call clearing message.
- 2 Mandatory in the first call clearing message, including when the RELEASE COMPLETE message is sent as a result of an error handling condition.
- 3 Included if the network provides information that can be presented to the user.
- 4 The minimum length is 2 octets; the maximum length is network dependent and is either 34 or 82 octets.
- 5 User-user information may be sent if RELEASE COMPLETE is the first clearing message and the access connection has not yet reached the active state and Q.931/X.25 mapping service is provided by the network. However, user-user information is not sent if the access connection has reached the active state since X.25 [5] procedures would be used for this information transfer.
- 6 The minimum length is 2 octets; the standard default maximum length is 131 octets.

Superseded by a more recent version

3.2.9 SETUP

This message is sent by the calling user to the network and by the network to the called user to initiate access connection establishment. See Table 3-31.

TABLE 3-31/Q.931

SETUP message content

Message type: SETUP Significance: global Direction: both				
Information element	Reference (subclause)	Direction	Type	Length
Protocol discriminator	4.2	Both	M	1
Call reference	4.3	Both	M	2-*
Message type	4.4	Both	M	1
Bearer capability	4.5	Both	M (Note 1)	4-12
Channel identification	4.5	Both	O (Note 2)	2-*
Progress indicator	4.5	u → n	O (Note 3)	2-4
Display	4.5	n → u	O (Note 4)	(Note 5)
Information rate	4.7	n → u	O (Note 6)	2-6
End-end transit delay	4.7	n → u	O (Note 8)	2-11
Transit delay selection and indication	4.7	n → u	O (Note 7)	2-5
Packet layer binary parameters	4.7	n → u	O (Note 9)	2-3
Packet layer window size	4.7	n → u	O (Note 10)	2-4
Packet size	4.7	n → u	O (Note 11)	2-4
Closed user group	4.7	n → u	O (Note 12)	4-7
Reverse charging indication	4.7	n → u	O (Note 13)	3
Calling party number	4.5	Both	O (Note 14)	2-*
Calling party subaddress	4.5	Both	O (Note 15)	2-23
Called party number	4.5	n → u	O (Note 16)	2-*
Called party subaddress	4.5	n → u	O (Note 17)	2-23
Redirecting number	4.7	n → u	O (Note 18)	2-4
User-user	4.5	n → u	O (Note 19)	(Note 20)

Superseded by a more recent version

TABLE 3-31/Q.931 (cont.)

NOTES

- 1 May be used to describe a CCITT telecommunication service involving packet-mode access connections, if appropriate.
- 2 Mandatory in the network-to-user direction. Included in the user-to-network direction when the user wants to indicate a channel. If not included, its absence is interpreted as “any channel acceptable”.
- 3 Included in the event of interworking within a private network.
- 4 Included if the network provides information that can be presented to the user.
- 5 The minimum length is 2 octets; the maximum length is network dependent and is either 34 or 82 octets.
- 6 Included in the network-to-user direction if the network implements X.25 [5]/Q.931 information element mapping and provides indication to the called user of the information rate for the call.
- 7 Included in the network-to-user direction if the network implements X.25/Q.931 information element mapping and provides indication to the called user of the maximum permissible transit delay for the call.
- 8 Included in the network-to-user direction if the network implements X.25/Q.931 information element mapping and provides indication to the called user of the end-end transit delay for the call.
- 9 Included in the network-to-user direction if the network implements X.25/Q.931 information element mapping and provides indication to the called user of the packet layer binary parameters for the call.
- 10 Included in the network-to-user direction if the network implements X.25/Q.931 information element mapping and provides indication to the called user of the packet layer window size for the call.
- 11 Included in the network-to-user direction if the network implements X.25/Q.931 information element mapping and provides indication to the called user of the packet size for the call.
- 12 Included in the network-to-user direction if the network implements X.25/Q.931 information element mapping and provides indication to the called party of the closed user group that belongs for that call.
- 13 Included in the network-to-user direction if the network implements X.25/Q.931 information element mapping and provides indication to the called party of the reverse charging request that applies for that call.
- 14 Included in the user-to-network direction depending on the user/network identification requirements. Included in the network-to-user direction if the network implements X.25/Q.931 information element mapping and provides indication to the called user of the calling party number.
- 15 Included in the user-to-network direction depending on the user/network identification requirements. Included in the network-to-user direction if the network implements X.25/Q.931 information element mapping and provides indication to the called user of the calling party subaddress.
- 16 Included in the network-to-user direction if the network implements X.25/Q.931 information element mapping and provides indication to the called user of the called party number.
- 17 Included in the network-to-user direction if the network implements X.25/Q.931 information element mapping and provides indication to the called user of the called party subaddress.
- 18 Included in the network-to-user direction if the network implements X.25/Q.931 information element mapping and provides indication to the called user of the number from which a call diversion or transfer was invoked.
- 19 Included in the network-to-user direction if the calling user included user information and the network implements X.25/Q.931 information element mapping.
- 20 The minimum length is 2 octets; the standard default maximum length is 131 octets.

Superseded by a more recent version

3.2.10 STATUS

This message is sent by the user or the network in response to a STATUS ENQUIRY message or at any time to report certain error conditions listed in 5.8. See Table 3-32.

TABLE 3-32/Q.931

STATUS message content

Message Type: STATUS Significance: local Direction: both				
Information element	Reference (subclause)	Direction	Type	Length
Protocol discriminator	4.2	Both	M	1
Call reference	4.3	Both	M	2-*
Message type	4.4	Both	M	1
Cause	4.5	Both	M	4-32
Call state	4.5	Both	M	3
Display	4.5	n → u	O (Note 1)	(Note 2)
NOTES				
1 Included if the network provides information that can be presented to the user.				
2 The minimum length is 2 octets; the maximum length is network dependent and is either 34 or 82 octets.				

3.2.11 STATUS ENQUIRY

The STATUS ENQUIRY message is sent by the user or the network at any time to solicit a STATUS message from the peer layer 3 entity. Sending a STATUS message in response to a STATUS ENQUIRY message is mandatory. See Table 3-33.

TABLE 3-33/Q.931

STATUS ENQUIRY message content

Message type: STATUS ENQUIRY Significance: local Direction: both				
Information element	Reference (subclause)	Direction	Type	Length
Protocol discriminator	4.2	Both	M	1
Call reference	4.3	Both	M	2-*
Message type	4.4	Both	M	1
Display	4.5	n → u	O (Note 1)	(Note 2)
NOTES				
1 Included if the network provides information that can be presented to the user.				
2 The minimum length is 2 octets; the maximum length is network dependent and is either 34 or 82 octets.				

Superseded by a more recent version

3.3 Messages for user signalling bearer service control

Table 3-34 summarizes the messages for the control of non-call associated temporary signalling connections and the transfer of user-user information.

TABLE 3-34/Q.931

Messages for temporary signalling connection control

	Reference (subclause)
<i>Call establishment messages:</i>	
ALERTING	3.3.1
CALL PROCEEDING	3.3.2
CONNECT	3.3.4
CONNECT ACKNOWLEDGE	3.3.5
SETUP	3.3.9
SETUP ACKNOWLEDGE	3.3.10
<i>Call information phase messages:</i>	
USER INFORMATION	3.3.13
<i>Call clearing messages:</i>	
RELEASE	3.3.7
RELEASE COMPLETE	3.3.8
<i>Miscellaneous messages:</i>	
CONGESTION CONTROL INFORMATION	3.3.3
STATUS	3.3.6
STATUS ENQUIRY	3.3.11
	3.3.12
NOTE – In Recommendation Q.931 (1988), support of user-user signalling was included for a number of reasons, including support of additional compatibility checking upon bilateral agreement with other users or in accordance with other standards (e.g. Recommendation X.213 [23]). To utilise this capability, the User-user information element can be included in the ALERTING, CONNECT, RELEASE, RELEASE COMPLETE and SETUP messages. Details on this capability (explicit and implicit Type 1 user-user signalling) are given in Recommendation Q.957 [54].	

Superseded by a more recent version

3.3.1 ALERTING

This message is sent by the called user to the network, and by the network to the calling user, to indicate that called user alerting has been initiated. See Table 3-35.

TABLE 3-35/Q.931

ALERTING message content

Message type: ALERTING Significance: global Direction: both				
Information element	Reference (subclause)	Direction	Type	Length
Protocol discriminator	4.2	Both	M	1
Call reference	4.3	Both	M	2-*
Message type	4.4	Both	M	1
Channel identification	4.5	u → n	O (Note 1)	2-*
Display	4.5	n → u	O (Note 2)	(Note 3)
NOTES				
1 Mandatory if this is the first message in response to SETUP, unless the user accepts the D-channel indicated in the SETUP message.				
2 Included if the network provides information that can be presented to the user.				
3 The minimum length is 2 octets; the maximum length is network dependent and is either 34 or 82 octets.				

Superseded by a more recent version

3.3.2 CALL PROCEEDING

This message is sent by the called user to the network or by the network to the calling user to indicate that requested call establishment has been initiated and no more call establishment information will be accepted. See Table 3-36.

TABLE 3-36/Q.931

CALL PROCEEDING message content

Message type: CALL PROCEEDING Significance: local Direction: both				
Information element	Reference (subclause)	Direction	Type	Length
Protocol discriminator	4.2	Both	M	1
Call reference	4.3	Both	M	2-*
Message type	4.4	Both	M	1
Channel identification	4.5	Both	O (Note 1)	2-*
Display	4.5	n → u	O (Note 2)	(Note 3)
NOTES				
1 Mandatory in the network to user direction if this message is the first message in response to a SETUP. Mandatory in the user to network direction if this message is the first message in response to a SETUP, unless the user accepts the D-channel indicated in the SETUP message.				
2 Included if the network provides information that can be presented to the user.				
3 The minimum length is 2 octets; the maximum length is network dependent and is either 34 or 82 octets.				

Superseded by a more recent version

3.3.3 CONGESTION CONTROL

This message is sent by the network or the user to indicate the establishment or termination of flow control on the transmission of USER INFORMATION messages. See Table 3-37.

TABLE 3-37/Q.931

CONGESTION CONTROL message content

Message type: CONGESTION CONTROL Significance: local (Note 1) Direction: both				
Information element	Reference (subclause)	Direction	Type	Length
Protocol discriminator	4.2	Both	M	1
Call reference	4.3	Both	M	2-*
Message type	4.4	Both	M	1
Congestion level	4.5	Both	M	1
Cause	4.5	Both	M	4-32
Display	4.5	n → u	O (Note 2)	(Note 3)
NOTES				
1 This message has local significance, but may carry information of global significance.				
2 Included if the network provides information that can be presented to the user.				
3 The minimum length is 2 octets; the maximum length is network dependent and is either 34 or 82 octets.				

Superseded by a more recent version

3.3.4 CONNECT

This message is sent by the called user to the network, and by the network to the calling user, to indicate call acceptance by the called user. See Table 3-38.

TABLE 3-38/Q.931

CONNECT message content

Message type: CONNECT Significance: local Direction: both				
Information element	Reference (subclause)	Direction	Type	Length
Protocol discriminator	4.2	Both	M	1
Call reference	4.3	Both	M	2-*
Message type	4.4	Both	M	1
Channel identification	4.5	u → n	O (Note 1)	2-*
Display	4.5	n → u	O (Note 2)	(Note 3)
NOTES				
1 Mandatory if this is the first message in response to a SETUP, unless the user accepts the D-channel indicated in the SETUP message.				
2 Included if the network provides information that can be presented to the user.				
3 The minimum length is 2 octets; the maximum length is network dependent and is either 34 or 82 octets.				

Superseded by a more recent version

3.3.5 CONNECT ACKNOWLEDGE

This message is sent by the network to the called user to indicate that the user has been awarded the call. It may also be sent by the calling user to the network to allow symmetrical call control procedures. See Table 3-39.

TABLE 3-39/Q.931

CONNECT ACKNOWLEDGE message content

Message type: CONNECT ACKNOWLEDGE Significance: local Direction: both				
Information element	Reference (subclause)	Direction	Type	Length
Protocol discriminator	4.2	Both	M	1
Call reference	4.3	Both	M	2-*
Message type	4.4	Both	M	1
Display	4.5	n → u	O (Note 1)	(Note 2)
NOTES				
1 Included if the network provides information that can be presented to the user.				
2 The minimum length is 2 octets; the maximum length is network dependent and is either 34 or 82 octets.				

Superseded by a more recent version

3.3.6 INFORMATION

This message is sent by the user or the network to provide additional information. It may be used to provide information for call establishment (e.g. overlap sending and receiving) or miscellaneous call-related information. See Table 3-40.

TABLE 3-40/Q.931

INFORMATION message content

Message type: INFORMATION				
Significance: local (Note 1)				
Direction: both				
Information element	Reference (subclause)	Direction	Type	Length
Protocol discriminator	4.2	Both	M	1
Call reference	4.3	Both	M	2-*
Message type	4.4	Both	M	1
Sending complete	4.5	Both	O (Note 2)	1
Cause	4.5	n → u	O (Note 3)	2-32
Display	4.5	n → u	O (Note 4)	(Note 5)
Keypad facility	4.5	u → n	O (Note 6)	2-34
Called party number	4.5	Both	O (Note 7)	2-*
NOTES				
1 This message has local significance, but may carry information of global significance.				
2 Included when the user optionally indicates completion of overlap sending to the network, or if the network optionally indicates completion of overlap receiving to the user.				
3 Included when the network optionally conveys additional information pertaining to user-user signalling (see clause 7).				
4 Included if the network provides information that can be presented to the user.				
5 The minimum length is 2 octets; the maximum length is network dependent and is either 34 or 82 octets.				
6 Either the Called party number or the Keypad facility information element is included by the user to convey called party number information to the network during overlap sending.				
7 The Called party number information element is included by the network to convey called party number information to the user during overlap receiving.				

Superseded by a more recent version

3.3.7 RELEASE

This message is sent by the user or the network to indicate that the equipment sending the message has disconnected the channel (if any), and intends to release the channel and the call reference, and that the receiving equipment should release the channel and prepare to release the call reference after sending RELEASE COMPLETE. See Table 3-41.

TABLE 3-41/Q.931

RELEASE message content

Message type: RELEASE Significance: local (Note 1) Direction: both				
Information element	Reference (subclause)	Direction	Type	Length
Protocol discriminator	4.2	Both	M	1
Call reference	4.3	Both	M	2-*
Message type	4.4	Both	M	1
Cause	4.5	Both	O (Note 2)	2-32
Display	4.5	n → u	O (Note 3)	(Note 4)

NOTES

- 1 This message has local significance; however, it may carry information of global significance when used as the first call clearing message.
- 2 Mandatory in the first call clearing message, including when the RELEASE message is sent as a result of an error handling condition.
- 3 Included if the network provides information that can be presented to the user.
- 4 The minimum length is 2 octets; the maximum length is network dependent and is either 34 or 82 octets.

Superseded by a more recent version

3.3.8 RELEASE COMPLETE

This message is sent by the user or the network to indicate that the equipment sending the message has released the channel (if any) and call reference. The channel is available for reuse, and the receiving equipment shall release the call reference. See Table 3-42.

TABLE 3-42/Q.931

RELEASE COMPLETE message content

Message type: RELEASE COMPLETE Significance: local (Note 1) Direction: both				
Information element	Reference (subclause)	Direction	Type	Length
Protocol discriminator	4.2	Both	M	1
Call reference	4.3	Both	M	2-*
Message type	4.4	Both	M	1
Cause	4.5	Both	O (Note 2)	2-32
Display	4.5	n → u	O (Note 3)	(Note 4)
NOTES				
1 This message has local significance; however, it may carry information of global significance when used as the first call clearing message.				
2 Mandatory in the first call clearing message, including when the RELEASE message is sent as a result of an error handling condition.				
3 Included if the network provides information that can be presented to the user.				
4 The minimum length is 2 octets; the maximum length is network dependent and is either 34 or 82 octets.				

Superseded by a more recent version

3.3.9 SETUP

This message is sent by the calling user to the network and by the network to the called user to initiate call establishment. See Table 3-43.

TABLE 3-43/Q.931

SETUP message content

Message type: SETUP Significance: global Direction: both				
Information element	Reference (subclause)	Direction	Type	Length
Protocol discriminator	4.2	Both	M	1
Call reference	4.3	Both	M	2-*
Message type	4.4	Both	M	1
Sending complete	4.5	Both	O (Note 1)	1
Bearer capability	4.5	Both	M (Note 2)	6-8
Channel identification	4.5	Both	M	3-*
Network specific facility	4.5	Both	O (Note 3)	2-*
Display	4.5	n → u	O (Note 4)	(Note 5)
Keypad facility	4.5	u → n	O (Note 6)	2-34
Calling party number	4.5	Both	O (Note 7)	2-*
Calling party subaddress	4.5	Both	O (Note 8)	2-23
Called party number	4.5	Both	O (Note 9)	2-*
Called party subaddress	4.5	Both	O (Note 10)	2-23
Transit network selection	4.5	u → n	O (Note 11)	2-*
Low layer compatibility	4.5	Both	O (Note 12)	2-18
High layer compatibility	4.5	Both	O (Note 13)	2-5

Superseded by a more recent version

TABLE 3-43/Q.931 (cont.)

NOTES

- 1 Included if the user or the network optionally indicates that all information necessary for call establishment is included in the SETUP message.
- 2 The Bearer capability and Low layer compatibility information elements may be used to describe a CCITT telecommunication service, if appropriate.
- 3 Included by the calling user or the network to indicate network specific facilities information (see Annex E).
- 4 Included if the network provides information that can be presented to the user.
- 5 The minimum length is 2 octets; the maximum length is network dependent and is either 34 or 82 octets.
- 6 Either the Called party number or the Keypad facility information element is included by the user to convey called party number information to the network during overlap sending. The Keypad facility information element may also be included by the user to convey other call establishment information to the network.
- 7 May be included by the calling user or the network to identify the calling user.
- 8 Included in the user-to-network direction when the calling user wants to indicate the calling party subaddress. Included in the network-to-user direction if the calling user included a Calling party subaddress information element in the SETUP message.
- 9 Either the Called party number or the Keypad facility information element is included by the user to convey called party number information to the network during overlap sending. The Called party number information element is included by the network when called party number information is conveyed to the user.
- 10 Included in the user-to-network direction when the calling user wants to indicate the called party subaddress. Included in the network-to-user direction if the calling user included a Called party subaddress information element in the SETUP message.
- 11 Included by the calling user to select a particular transit network (see Annex C).
- 12 Included in the user-to-network direction when the calling user wants to pass low layer compatibility information to the called user. Included in the network-to-user direction if the calling user included a Low layer compatibility information element in the SETUP message.
- 13 Included in the user-to-network direction when the calling user wants to pass high layer compatibility information to the called user. Included in the network-to-user direction if the calling user included a High layer compatibility information element in the SETUP message.

Superseded by a more recent version

3.3.10 SETUP ACKNOWLEDGE

This message is sent by the network to the calling user, or by the called user to the network, to indicate that call establishment has been initiated but additional information may be required. See Table 3-44.

TABLE 3-44/Q.931

SETUP ACKNOWLEDGE message content

Message type: SETUP ACKNOWLEDGE Significance: local Direction: both				
Information element	Reference (subclause)	Direction	Type	Length
Protocol discriminator	4.2	Both	M	1
Call reference	4.3	Both	M	2-*
Message type	4.4	Both	M	1
Channel identification	4.5	Both	O (Note 1)	2-*
Display	4.5	n → u	O (Note 2)	(Note 3)
NOTES				
1 Mandatory in all cases, except when the user accepts the D-channel indicated in the SETUP message.				
2 Included if the network provides information that can be presented to the user.				
3 The minimum length is 2 octets; the maximum length is network dependent and is either 34 or 82 octets.				

3.3.11 STATUS

This message is sent by the user or the network in response to a STATUS ENQUIRY message or at any time during a call to report certain error conditions listed in 5.8. See Table 3-45.

TABLE 3-45/Q.931

STATUS message content

Message type: STATUS Significance: local Direction: both				
Information element	Reference (subclause)	Direction	Type	Length
Protocol discriminator	4.2	Both	M	1
Call reference	4.3	Both	M	2-*
Message type	4.4	Both	M	1
Cause	4.5	Both	M	4-32
Call state	4.5	Both	M	3
Display	4.5	n → u	O (Note 1)	(Note 2)
NOTES				
1 Included if the network provides information that can be presented to the user.				
2 The minimum length is 2 octets; the maximum length is network dependent and is either 34 or 82 octets.				

Superseded by a more recent version

3.3.12 STATUS ENQUIRY

This message is sent by the user or the network at any time to solicit a STATUS message from the peer layer 3 entity. Sending a STATUS message in response to a STATUS ENQUIRY message is mandatory. See Table 3-46.

TABLE 3-46/Q.931

STATUS ENQUIRY message content

Message type: STATUS ENQUIRY Significance: local Direction: both				
Information element	Reference (subclause)	Direction	Type	Length
Protocol discriminator	4.2	Both	M	1
Call reference	4.3	Both	M	2-*
Message type	4.4	Both	M	1
Display	4.5	n → u	O (Note 1)	(Note 2)
NOTES				
1 Included if the network provides information that can be presented to the user.				
2 The minimum length is 2 octets; the maximum length is network dependent and is either 34 or 82 octets.				

3.3.13 USER INFORMATION

This message is sent by the user to the network to transfer information to the remote user. This message is also sent by the network to the user to deliver information from the other user. See Table 3-47.

TABLE 3-47/Q.931

USER INFORMATION message content

Message type: USER INFORMATION Significance: access Direction: both				
Information element	Reference (subclause)	Direction	Type	Length
Protocol discriminator	4.2	Both	M	1
Call reference	4.3	Both	M	2-*
Message type	4.4	Both	M	1
More data	4.5	Both	O (Note)	1
User-user	4.5	Both	M	2-255
NOTE – Included by the sending user to indicate that another USER INFORMATION message pertaining to the same message block will follow.				

Superseded by a more recent version

3.4 Messages with the global call reference

Table 3-48 summarizes the messages which may use the global call reference defined in 4.3.

TABLE 3-48/Q.931

Messages used with the global call reference

Messages	Reference (subclause)
RESTART	3.4.1
RESTART ACKNOWLEDGE	3.4.2
STATUS	3.4.3

3.4.1 RESTART

This message is sent by the user or network to request the recipient to restart (i.e. return to an idle condition) the indicated channel(s) or interface. See Table 3-49.

TABLE 3-49/Q.931

RESTART message content

Message type: RESTART Significance: local Direction: both				
Information element	Reference (subclause)	Direction	Type	Length
Protocol discriminator	4.2	Both	M	1
Call reference	4.3	Both	M (Note 1)	2-*
Message type	4.4	Both	M	1
Channel identification	4.5	Both	O (Note 2)	2-*
Display	4.5	n → u	O (Note 3)	(Note 4)
Restart indicator	4.5	Both	M	3
NOTES 1 This message is sent with the global call reference defined in 4.3. 2 Included when necessary to indicate the particular channel(s) to be restarted. 3 Included if the network provides information that can be presented to the user. 4 The minimum length is 2 octets; the maximum length is network dependent and is either 34 or 82 octets.				

Superseded by a more recent version

3.4.2 RESTART ACKNOWLEDGE

This message is sent to acknowledge the receipt of the RESTART message and to indicate that the requested restart is complete. See Table 3-50.

TABLE 3-50/Q.931

RESTART ACKNOWLEDGE message content

Message type: RESTART ACKNOWLEDGE Significance: local Direction: both				
Information element	Reference (subclause)	Direction	Type	Length
Protocol discriminator	4.2	Both	M	1
Call reference	4.3	Both	M (Note 1)	2-*
Message type	4.4	Both	M	1
Channel identification	4.5	Both	O (Note 2)	2-*
Display	4.5	n → u	O (Note 3)	(Note 4)
Restart indicator	4.5	Both	M	3
NOTES				
1 This message is sent with the global call reference defined in 4.3.				
2 Included when necessary to indicate the particular channel(s) which have been restarted. May be repeated in the case of non-associated signalling that controls two or more interfaces.				
3 Included if the network provides information that can be presented to the user.				
4 The minimum length is 2 octets; the maximum length is network dependent and is either 34 or 82 octets.				

Superseded by a more recent version

3.4.3 STATUS

This message is sent by the user or the network at any time during a call to report certain error conditions listed in 5.8. See Table 3-51.

TABLE 3-51/Q.931

STATUS message content

Message type: STATUS Significance: local Direction: both				
Information element	Reference (subclause)	Direction	Type	Length
Protocol discriminator	4.2	Both	M	1
Call reference	4.3	Both	M (Note 1)	2-*
Message type	4.4	Both	M	1
Cause	4.5	Both	M	4-32
Call state	4.5	Both	M	3
Display	4.5	n → u	O (Note 2)	(Note 3)
NOTES				
1 This message may be sent with the global call reference defined in 4.3.				
2 Included if the network provides information that can be presented to the user.				
3 The minimum length is 2 octets; the maximum length is network dependent and is either 34 or 82 octets.				

4 General message format and information elements coding

The figures and text in this clause describe message contents. Within each octet, the bit designated “bit 1” is transmitted first, followed by bits 2, 3, 4, etc. Similarly, the octet shown at the top of each figure is sent first.

4.1 Overview

Within this protocol, every message shall consist of the following parts:

- a) protocol discriminator;
- b) call reference;
- c) message type;
- d) other information elements, as required.

Information elements a), b) and c) are common to all the messages and shall always be present, while information element d) is specific to each message type.

This organization is illustrated in the example shown in Figure 4-1.

A particular message may contain more information than a particular (user or network) equipment needs or can understand. All equipment should be able to ignore any extra information, present in a message, which is not required for the proper operation of that equipment. For example, a user may ignore the calling party number if that number is of no interest to the user when a SETUP message is received.

Superseded by a more recent version

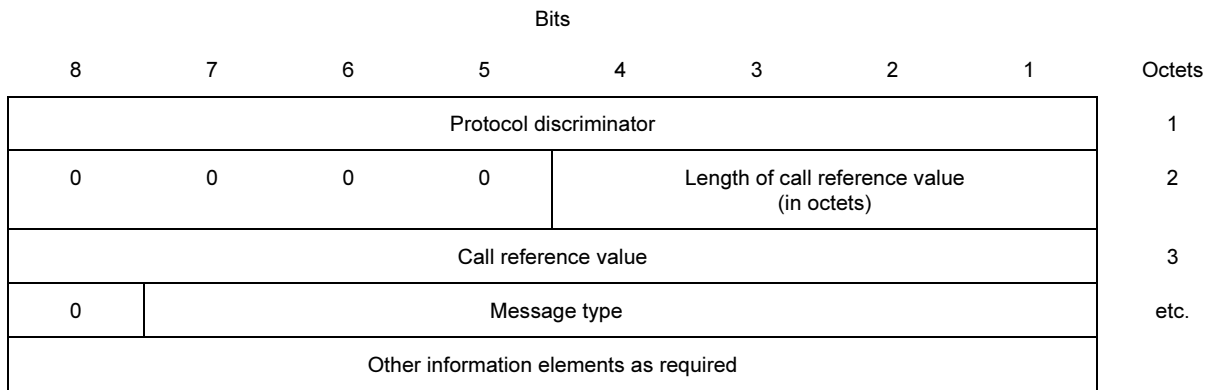

FIGURE 4-1/Q.931

General message organization example

Unless specified otherwise, a particular information element may be present only once in a given message.

The term “default” implies that the value defined should be used in the absence of any assignment, or the negotiation of alternative values.

When a field, such as the call reference value, extends over more than one octet, the order of bit values progressively decreases as the octet number increases. The least significant bit of the field is represented by the lowest numbered bit of the highest-numbered octet of the field.

4.2 Protocol discriminator

The purpose of the protocol discriminator is to distinguish messages for user-network call control from other messages (to be defined). It also distinguishes messages of this Standard from those OSI network layer protocol units which are coded to other CCITT Recommendations and other standards.

NOTE – A protocol discriminator field is also included in the User-user information element to indicate the user protocol within the user information; however, the coding of the protocol discriminator in this case is shown in 4.5.30.

The protocol discriminator is the first part of every message. The protocol discriminator is coded according to Table 4-1.

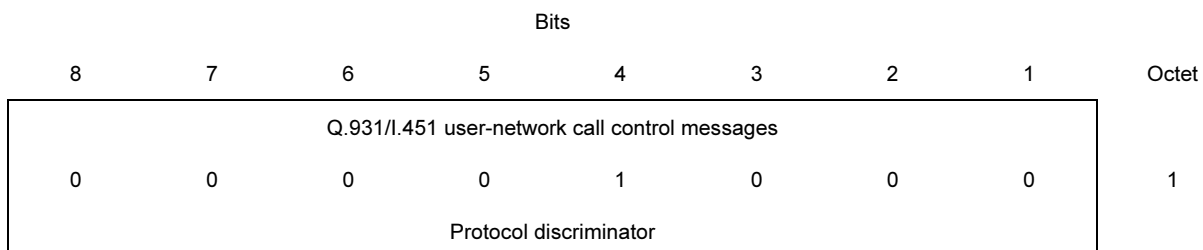

FIGURE 4-2/Q.931

Protocol discriminator

Superseded by a more recent version

TABLE 4-1/Q.931

Protocol discriminator

8	7	6	5	4	3	2	1
Error! Assigned in subclause 4.5.30; not available for use in the message protocol discriminator							
0	0	0	0	1	0	0	0
Recommendation Q.931/I.451 user-network call control messages							
Error! Reserved for other network layer or layer 3 protocols, including Recommendation X.25 [5] (Note)							
Error! National use							
Error! Reserved for other network layer or layer 3 protocols, including Recommendation X.25 (Note)							
All other values are reserved.							
NOTE – These values are reserved to discriminate these protocol discriminators from the first octet of a Recommendation X.25 packet including general format identifier.							

4.3 Call reference

The purpose of the call reference is to identify the call or facility registration/cancellation request at the local user-network interface to which the particular message applies. The call reference does not have end-to-end significance across ISDNs.

The call reference is the second part of every message. The call reference is coded as shown in Figure 4-3. The length of the call reference value is indicated in octet 1, bits 1-4. The default maximum length of the call reference information element is three octets long. The actions taken by the receiver are based on the numerical value of the call reference and are independent of the length of the call reference information element.

At a minimum, all networks and users must be able to support a call reference value of one octet for a basic user-network interface, and a call reference value of two octets for a primary rate interface.

As a network option for a primary rate interface, the call reference value may be one octet also. In this case, a call reference value up to 127 may be sent in one or two octets.

The call reference information element includes the call reference value and the call reference flag.

Call reference values are assigned by the originating side of the interface for a call. These values are unique to the originating side only within a particular D-Channel layer two logical link connection. The call reference value is assigned at the beginning of a call and remains fixed for the lifetime of a call (except in the case of call suspension). After a call ends, or, after a successful suspension, the associated call reference value may be reassigned to a later call. Two identical call reference values on the same D-Channel layer two logical link connection may be used when each value pertains to a call originated at opposite ends of the link.

Superseded by a more recent version

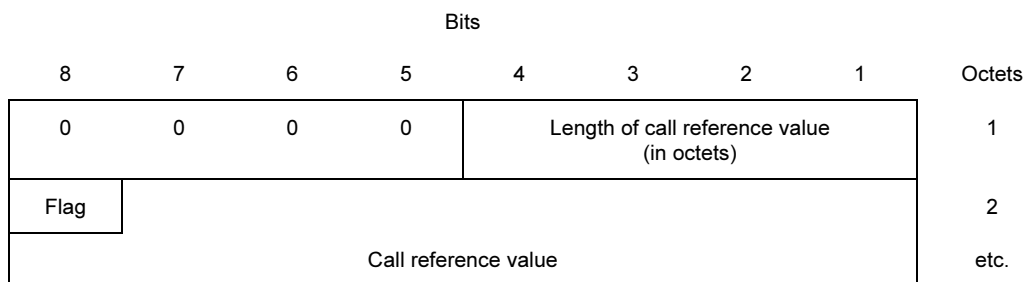

NOTE – For call reference flag (octet 2):

bit

Error! Error!

1 the message is sent to the side that originates the call reference.

FIGURE 4-3/Q.931

Call reference information element

The call reference flag can take the values “0” or “1”. The call reference flag is used to identify which end of the layer two logical link originated a call reference. The origination side always sets the call reference flag to “0”. The destination side always sets the call reference flag to a “1”.

Hence the call reference flag identifies who allocated the call reference value for this call and the only purpose of the call reference flag is to resolve simultaneous attempts to allocate the same call reference value.

The call reference flag also applies to functions which use the global call reference (e.g. restart procedures).

NOTES

1 The call reference information element containing a dummy call reference is one octet long and is coded “0000 0000”. The use of the dummy call reference is specified in Recommendation Q.932.

2 The numerical value of the global call reference is zero. The equipment receiving a message containing the global call reference should interpret the message as pertaining to all call references associated with the appropriate data link connection identifier. See Figure 4-5.

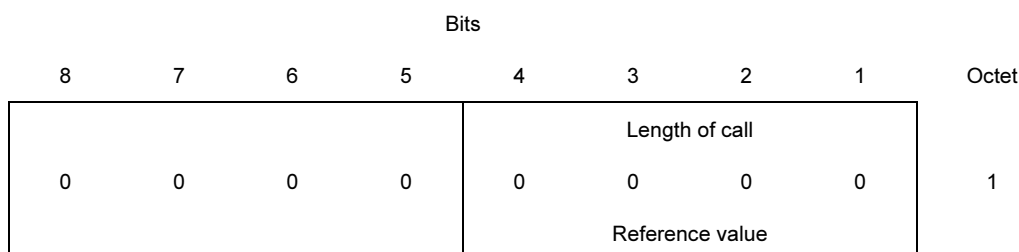
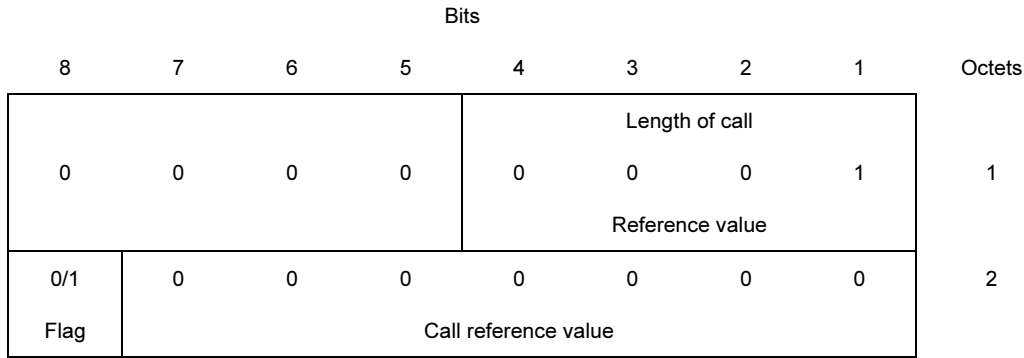

FIGURE 4-4/Q.931

Dummy call reference

Superseded by a more recent version



a) One octet call reference value

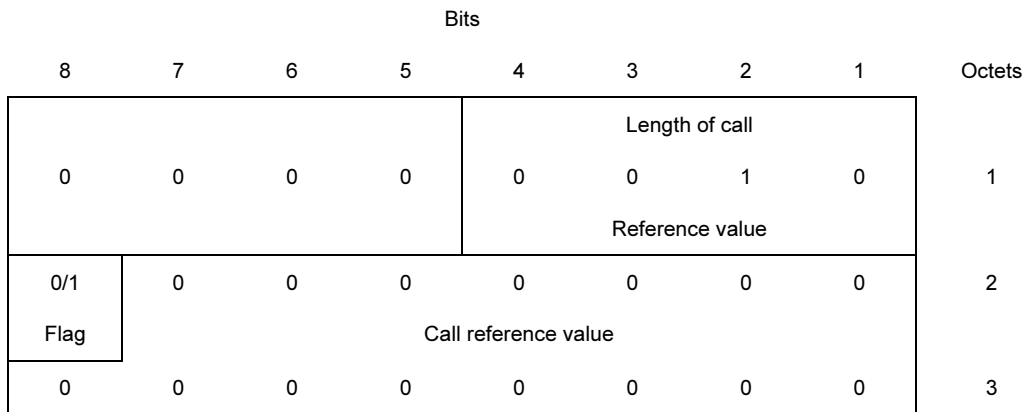

b) Two octet call reference value

FIGURE 4-5/Q.931

Examples of the encoding for global call reference

4.4 Message type

The purpose of the message type is to identify the function of the message being sent.

The message type is the third part of every message. The message type is coded as shown in Figure 4-6 and Table 4-2.

Bit 8 is reserved for possible future use as an extension bit.

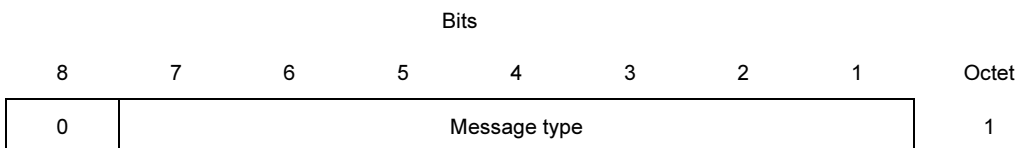

FIGURE 4-6/Q.931

Message type

Superseded by a more recent version

TABLE 4-2/Q.931

Message types

Bits	
8	7 6 5 4 3 2 1
0 0 0 0 0 0 0 0	Escape to nationally specific message type (Note)
0 0 0 - - - - -	<i>Call establishment message:</i>
0 0 0 0 1	– ALERTING
0 0 0 1 0	– CALL PROCEEDING
0 0 1 1 1	– CONNECT
0 1 1 1 1	– CONNECT KNOWLEDGE
0 0 0 1 1	– PROGRESS
0 0 1 0 1	– SETUP
0 1 1 0 1	– SETUP ACKNOWLEDGE
0 0 1 - - - - -	<i>Call information phase message:</i>
0 0 1 1 0	– RESUME
0 1 1 1 0	– RESUME ACKNOWLEDGE
0 0 0 1 0	– RESUME REJECT
0 0 1 0 1	– SUSPEND
0 1 1 0 1	– SUSPEND ACKNOWLEDGE
0 0 0 0 1	– SUSPEND REJECT
0 0 0 0 0	– USER INFORMATION
0 1 0 - - - - -	<i>Call clearing messages:</i>
0 0 1 0 1	– DISCONNECT
0 1 1 0 1	– RELEASE
1 1 0 1 0	– RELEASE COMPLETE
0 0 1 1 0	– RESTART
0 1 1 1 0	– RESTART ACKNOWLEDGE
0 1 1 - - - - -	<i>Miscellaneous messages:</i>
0 0 0 0 0	– SEGMENT
1 1 0 0 1	– CONGESTION CONTROL
1 1 0 1 1	– INFORMATION
0 1 1 1 0	– NOTIFY
1 1 1 0 1	– STATUS
1 0 1 0 1	– STATUS ENQUIRY

NOTE – When used, the message type is defined in the following octet(s), according to the

Superseded by a more recent version

4.5 Other information elements

4.5.1 Coding rules

The coding of other information elements follows the coding rules described below. These rules are formulated to allow each equipment which processes a message to find information elements important to it, and yet remain ignorant of information elements not important to that equipment.

Two categories of information elements are defined:

- a) single octet information elements (see diagrams a) and b) of Figure 4-7);
- b) variable length information elements (see diagram c) of Figure 4-7).

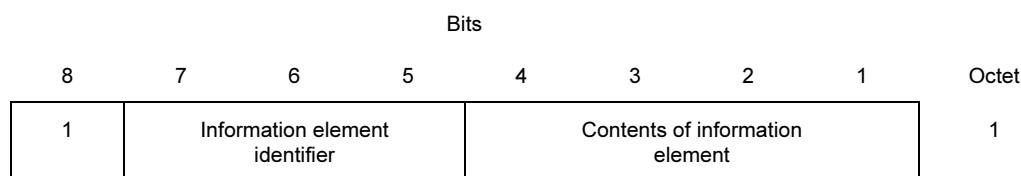

a) **Single octet information element format (type 1)**

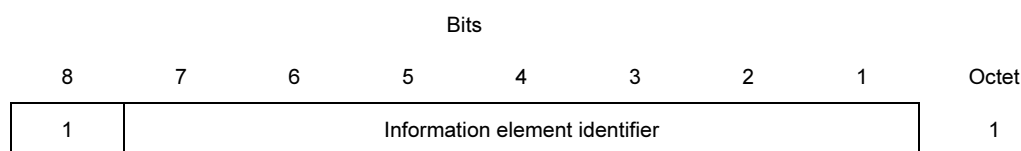

b) **Single octet information element format (type 2)**

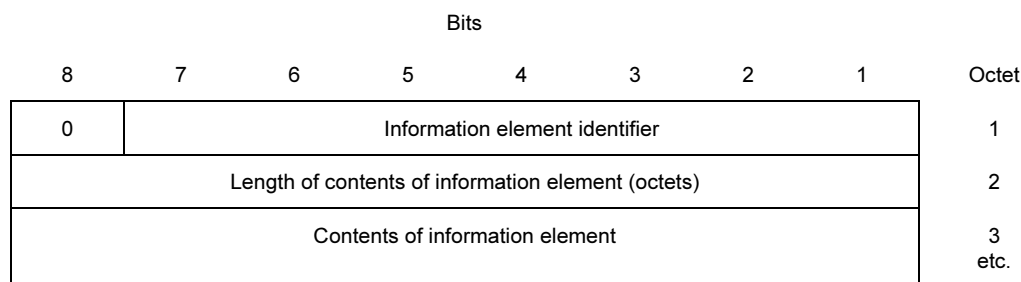

c) **Variable length information element format**

FIGURE 4-7/Q.931
Formats of information elements

For the information elements listed below, the coding of the information element identifier bits is summarized in Table 4-3.

Superseded by a more recent version

TABLE 4-3/Q.931

Information element identifier coding

Bits		Reference (subclause)	Maximum length (octets) (Note 1)
<u>8 7 6 5 4 3 2 1</u>			
1 : : : - - - -	<i>Single octet information elements:</i>		
0 0 0 - - - -	Reserved		
0 0 1 - - - -	Shift (Note 2)	4.5.3/4.5.4	1
0 1 0 0 0 0 0	More data	4.5.20	1
0 1 0 0 0 0 1	Sending complete	4.5.27	1
0 1 1 - - - -	Congestion level	4.5.14	1
1 0 1 - - - -	Repeat indicator	4.5.24	1
0 : : : : : :	<i>Variable length information element:</i>		
0 0 0 0 0 0 0	Segmented message	4.5.26	4
0 0 0 0 1 0 0	Bearer capability (Note 2)	4.5.5	12
0 0 0 1 0 0 0	Cause (Note 2)	4.5.12	32
0 0 1 0 0 0 0	Call identity	4.5.6	10
0 0 1 0 1 0 0	Call state	4.5.7	3
0 0 1 1 0 0 0	Channel identification (Note 2)	4.5.13	(Note 4)
0 0 1 1 1 1 0	Progress indicator (Note 2)	4.5.23	(Note 4)
0 1 0 0 0 0 0	Network-specific facilities (Note 2)	4.5.21	(Note 4)
0 1 0 0 1 1 1	Notification indicator	4.5.22	3
0 1 0 1 0 0 0	Display	4.5.16	34/82
0 1 0 1 0 0 1	Date/time	4.5.15	8
0 1 0 1 1 0 0	Keypad facility	4.5.18	34
0 1 1 0 1 0 0	Signal (Note 2)	4.5.28	3
1 0 0 0 0 0 0	Information rate	4.6.3	6
1 0 0 0 0 1 0	End-to-end transit delay	4.6.2	11
1 0 0 0 0 1 1	Transit delay selection and indication	4.6.9	5
1 0 0 0 1 0 0	Packet layer binary parameters	4.6.4	3
1 0 0 0 1 0 1	Packet layer window size	4.6.5	4
1 0 0 0 1 1 0	Packet size	4.6.6	4
1 0 0 0 1 1 1	Closed user group	4.6.1	7
1 0 0 1 0 1 0	Reverse charge indication	4.6.8	3
1 1 0 1 1 0 0	Calling party number	4.5.10	(Note 4)
1 1 0 1 1 0 1	Calling party subaddress	4.5.11	23
1 1 1 0 0 0 0	Called party number	4.5.8	(Note 4)
1 1 1 0 0 0 1	Called party subaddress	4.5.9	23
1 1 1 0 1 0 0	Redirecting number	4.6.7	(Note 4)
1 1 1 1 0 0 0	Transit network selection (Note 2)	4.5.29	(Note 4)
1 1 1 1 0 0 1	Restart indicator	4.5.25	3
1 1 1 1 1 0 0	Low layer compatibility (Note 2)	4.5.19	18
1 1 1 1 1 0 1	High layer compatibility (Note 2)	4.5.17	5
1 1 1 1 1 1 0	User-user	4.5.30	35/131
1 1 1 1 1 1 1	Escape for extension (Note 3)		
All other values are reserved (Note 5)			

Superseded by a more recent version

TABLE 4-3/Q.931 (concl.)

Information element identifier coding

NOTES

- 1 The length limits described for the variable length information elements take into account only the present CCITT standardized coding values. Future enhancements and expansions to this Recommendation will not be restricted to these limits.
- 2 This information element may be repeated.
- 3 This escape mechanism is limited to codesets 4, 5, 6 and 7 (see 4.5.2). When the escape for extension is used, the information element identifier is contained in octet-group 3 and the content of the information element follows in the subsequent octets as shown in Figure 4-8.
- 4 The maximum length is network dependent.
- 5 The reserved values with bits 5-8 coded "0000" are for future information elements for which comprehension by the receiver is required (see 5.8.7.1).

The descriptions of the information elements below are organized in alphabetical order. However, there is a particular order of appearance for each information element in a message within each codeset (see 4.5.2). The code values of the information element identifier for the variable length formats are assigned in ascending numerical order, according to the actual order of appearance of each information element in a message. This allows the receiving equipment to detect the presence or absence of a particular information element without scanning through an entire message.

Single octet information elements may appear at any point in the message. Two types of single octet information elements have been defined. Type 1 elements provide the information element identification in bit positions 7, 6, 5. The value "010" in these bit positions is reserved for Type 2 single octet elements.

Where the description of information elements in this Recommendation contains spare bits, these bits are indicated as being set to "0". In order to allow compatibility with future implementation, messages should not be rejected simply because a spare bit is set to "1".

The second octet of a variable length information element indicates the total length of the contents of that information element regardless of the coding of the first octet (i.e. the length starting with octet 3). It is the binary coding of the number of octets of the contents, with bit 1 as the least significant bit (2°).

An optional variable-length information element may be present, but empty. For example, a SETUP message may contain a called party number information element, the content of which is of zero length. This should be interpreted by the receiver as equivalent to that information element being absent. Similarly, an absent information element should be interpreted by the receiver as equivalent to that information element being empty.

The following rules apply for the coding of variable length information elements (octets 3, etc.):

- a) The first digit in the octet number identifies one octet or a group of octets.
- b) Each octet group is a self contained entity. The internal structure of an octet group may be defined in alternative ways.
- c) An octet group is formed by using some extension mechanism. The preferred extension mechanism is to extend an octet (N) through the next octet(s) (Na, Nb, etc.) by using bit 8 in each octet as an extension bit. The bit value "0" indicates that the octet continues through the next octet. The bit value "1" indicates that this octet is the last octet. If one octet (Nb) is present, also the preceding octets (N and Na) must be present.

In the format descriptions appearing in 4.5.5 etc., bit 8 is marked "0/1 ext," if another octet follows. Bit 8 is marked "1 ext," if this is the last octet in the extension domain.

Additional octets may be defined later ("1 ext." changed to "0/1 ext.") and equipments shall be prepared to receive such additional octets although the equipment need not be able to interpret or act upon the content of these octets.

- d) In addition to the extension mechanism defined above, an octet (N) may be extended through the next octet(s) (N1, N2 etc.) by indications in bits 7-1 (of octet N).

Superseded by a more recent version

- e) The mechanisms in c) and d) may be combined. Mechanism c) shall take priority in the ordering, such that all octets Na, Nb, etc. shall occur before octets N1, N2, etc. This rule shall apply even where the extension to octets N1, N2, etc. is indicated in one of octet Na, Nb, etc.
- f) Similar conventions apply even when mechanism d) is being repeated, i.e. octets N.1 shall occur before octets N.1.1, N.1.2, etc.
- g) Optional octets are marked with asterisks (*).

NOTES

- 1 It is not possible to use mechanism c) repeatedly, i.e. it is not possible to construct an octet 4a as this would become octet 4b.
- 2 Protocol designers should exercise care in using multiple extension mechanisms to ensure that a unique interpretation of the resultant coding is possible.
- 3 For a number of information elements there is a field that defines the coding standard. When the coding standard defines a national standard it is recommended that the national standard be structured similar to the information element defined in this Recommendation.

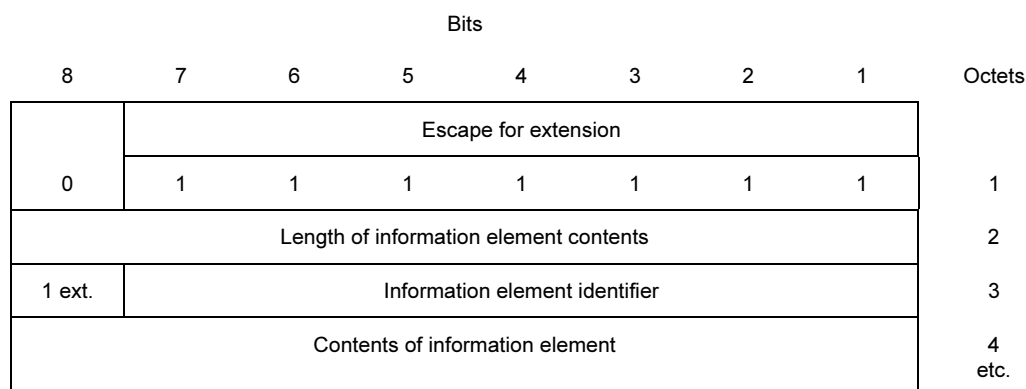

FIGURE 4-8/Q.931

Information element format using escape for extension

4.5.2 Extensions of codesets

There is a certain number of possible information element identifier values using the formatting rules described in 4.5.1; 128 from the variable length information element format and at least 8 from the single octet information element format.

One value in the single octet format is specified for shift operations described below. One other value in both the single octet and variable format is reserved. This leaves at least 133 information element identifier values available for assignment.

It is possible to expand this structure to eight codesets of at least 133 information element identifier values each. One common value in the single octet format is employed in each codeset to facilitate shifting from one codeset to another. The contents of this Shift information element identifies the codeset to be used for the next information element or elements. The codeset in use at any given time is referred to as the “active codeset”. By convention, codeset 0 is the initially active codeset.

Two codeset shifting procedures are supported: locking shift and non-locking shift.

Codeset 4 is reserved for use by ISO/IEC standards.

Codeset 5 is reserved for information elements reserved for national use.

Codeset 6 is reserved for information elements specific to the local network (either public or private).

Superseded by a more recent version

Codeset 7 is reserved for user-specific information elements.

The coding rules specified in 4.5.1 shall apply for information elements belonging to any active codeset.

Transitions from one active codeset to another (i.e. by means of the locking shift procedure) may only be made to a codeset with a higher numerical value than the codeset being left.

An information element belonging to codesets 4, 5, 6, or 7, may appear together with information elements belonging to codeset 0 (being the active codeset) by using the non-locking shift procedure (see 4.5.4).

A user of network equipment shall have the capability to recognize a Shift information element and to determine the length of the following information element, although the equipment need not be able to interpret and act upon the content of the information element. This enables the equipment to determine the start of a subsequent information element.

Codeset 7 information element shall be handled according to the procedures for unrecognized information elements (see 5.8.7.1) by the first exchange in the local network, unless allowed by a future service definition, bilateral agreement, or provision is made to support this across the local network for a specific user.

Codeset 6 is reserved for information elements specific to the local network (either public or private). As such they do not have significance across the boundaries between local networks, or across a national, or international boundary. Therefore, codeset 6 information elements shall be handled according to the procedures for unrecognized information elements (see 5.8.7.1) beyond local network boundary, unless allowed by bilateral agreement.

Codeset 5 is reserved for information elements reserved for national use. As such they do not have significance across an international boundary. Therefore, codeset 5 information elements shall be handled according to the procedures for unrecognized information elements (see 5.8.7.1) at the first exchange beyond the international boundary, unless there are bilateral agreements to the contrary.

Codeset 4 is reserved for information elements specified in ISO/IEC standards.

4.5.3 Locking shift procedure

The locking shift procedure employs an information element to indicate the new active codeset. The specified codeset remains active until another locking shift information element is encountered which specifies the use of another codeset. For example, codeset 0 is active at the start of message content analysis. If a locking shift to codeset 5 is encountered, the next information elements will be interpreted according to the information element identifiers assigned in codeset 5, until another shift information element is encountered.

This procedure is used only to shift to a higher order codeset than the one being left.

The locking shift is valid only within that message which contains the locking Shift information element. At the start of every message content analysis, the active codeset is codeset 0.

The locking Shift information element uses the single octet information element format and coding shown in Figure 4-9 and Table 4-4.

4.5.4 Non-locking shift procedure

The non-locking shift procedure provides a temporary shift to the specified lower or higher codeset. The non-locking shift procedure uses a single octet information element to indicate the codeset to be used to interpret the next single information element. After the interpretation of the next single information element, the active codeset is again used for interpreting any following information elements. For example, codeset 0 is active at the beginning of message content analysis. If a non-locking shift to codeset 6 is encountered, only the next information element is interpreted according to the information element identifiers assigned in codeset 6. After this information element is interpreted, codeset 0 will again be used to interpret the following information elements. A non-locking Shift information element indicating the current codeset shall not be regarded as an error.

Superseded by a more recent version

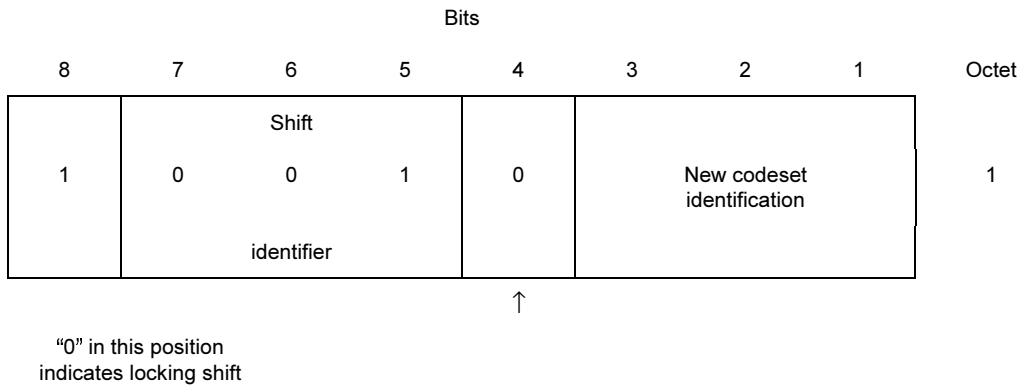

FIGURE 4-9/Q.931

Locking Shift information element

TABLE 4-4/Q.931

Locking Shift information element

<i>Codeset identification (bits 3 to 1):</i>	
Bits	
<u>3</u> <u>2</u> <u>1</u>	
0 0 0	Not applicable
0 0 1 } to 0 1 1 }	Reserved
1 0 0	Codeset 4: information elements for ISO/IEC use
1 0 1	Codeset 5: information elements for national use
1 1 0	Codeset 6: information elements specific to the local network (either public or private)
1 1 1	Codeset 7: user-specific information elements

A locking Shift information element shall not follow directly on a non-locking Shift information element. If this combination is received, it shall be interpreted as though a locking Shift information element only had been received.

The non-locking Shift information element uses the single octet information element format and coding shown in Figure 4-10 and Table 4-5.

Superseded by a more recent version

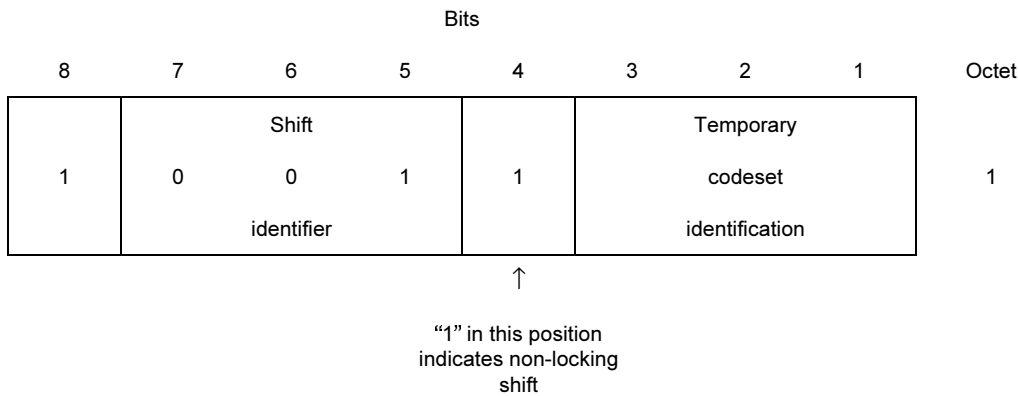

FIGURE 4-10/Q.931

Non-locking Shift information element

TABLE 4-5/Q.931

Non-locking Shift information element

<i>Codeset identification (bits 3 to 1):</i>	
Bits	
<u>3 2 1</u>	
0 0 0	Codeset 0 (initially active): Q.931 information elements
0 0 1 } to 0 1 1 }	Reserved
1 0 0	Codeset 4: information elements for ISO/IEC use
1 0 1	Codeset 5: information elements for national use
1 1 0	Codeset 6: information elements specific to the local network (either public or private)
1 1 1	Codeset 7: user-specific information elements

4.5.5 Bearer capability

The purpose of the Bearer capability information element is to indicate a requested Recommendation I.231 [6] bearer service to be provided by the network. It contains only information which *may* be used by the network (see Annex I). The use of the Bearer capability information element in relation to compatibility checking is described in Annex B.

The Bearer capability information element is coded as shown in Figure 4-11 and Table 4-6.

No default bearer capability may be assumed by the absence of this information element.

The maximum length of this information element is 12 octets.

NOTE – Future extensions to the codings of the Bearer capability information element should not be in conflict with the initially defined coding of the Low layer compatibility information element. See 4.5.19.

Superseded by a more recent version

		Bits							Octets	
		8	7	6	5	4	3	2	1	
		Bearer capability								
0		0	0	0	0	0	1	0	0	1
		Information element identifier								
		Length of the bearer capability contents							2	
1 ext.	Coding standard	Information transfer capability							3	
1 ext.	Transfer mode	Information transfer rate							4	
1 ext.	Rate multiplier							4.1* (Note 1)		
0/1 ext.	0 Layer 1	1 ident.	User information layer 1 protocol					5*		
0/1 ext.	Synch./ asynch	Negot.	User rate					5a* (Note 2)		
0/1 ext.	Intermediate rate		NIC on Tx	NIC on Rx	Flow control on Tx	Flow control on Rx	0 Spare	5b* (Note 3)		
0/1 ext.	Hdr/ no Hdr	Multi frame	Mode	LLI negot.	Assignor/ee	In-band neg.	0 Spare	5b* (Note 4)		
0/1 ext.	Number of stop bits		Number of data bits		Parity			5c* (Note 2)		
1 ext.	Duplex mode	Modem type					5d* (Note 2)			
1 ext.	1 Layer 2	0 ident.	User information layer 2 protocol					6*		
1 ext.	1 Layer 3	1 ident.	User information layer 3 protocol					7*		

NOTES

- 1 This octet is required if octet 4 indicates multirate (64 kbit/s base rate). Otherwise, it shall not be present.
- 2 This octet may be present if octet 3 indicates *unrestricted digital information* and octet 5 indicates either of the CCITT standardized rate adaptations V.110 and X.30 or V.120 [9]. It may also be present if octet 3 indicates 3.1 kHz audio and octet 5 indicates G.711.
- 3 This octet is significant only if octet 5 indicates CCITT standardized rate adaption (see Recommendation V.110 [7] and X.30 [8]).
- 4 This octet is significant only if octet 5 indicates CCITT standardized rate adaption see Recommendation V.120 [9].

FIGURE 4-11/Q.931

Bearer capability information element

Superseded by a more recent version

TABLE 4-6/Q.931

Bearer capability information element

Coding standard (octet 3)

Bits

7 6

- 0 0 CCITT standardized coding as described below
- 0 1 ISO/IEC standard (Note 1)
- 1 0 National standard (Note 1)
- 1 1 Standard defined for the network (either public or private) present on the network side of the interface (Note 1)

NOTE 1 – These other coding standards should be used only when the desired bearer capability cannot be represented with the CCITT-standardized coding.

Information transfer capability (octet 3)

Bits

5 4 3 2 1

- 0 0 0 0 0 Speech
- 0 1 0 0 0 Unrestricted digital information
- 0 1 0 0 1 Restricted digital information
- 1 0 0 0 0 3.1 kHz audio
- 1 0 0 0 1 Unrestricted digital information with tones/announcements (Note 2)
- 1 1 0 0 0 Video

All other values are reserved.

NOTE 2 – Unrestricted digital information with tones/announcements (UDI-TA) is the new information transfer attribute value that had previously been named “7 kHz audio” in Recommendation Q.931 (1988).

Transfer mode (octet 4)

Bits

7 6

- 0 0 Circuit mode
- 1 0 Packet mode

All other values are reserved.

Information transfer rate (octets 4 , bits 5 to 1)

Bits

5 4 3 2 1

- | | <i>Circuit mode</i> | <i>Paquet-mode</i> |
|-----------|---------------------------------|---|
| 0 0 0 0 0 | – | This code shall be used for packet mode calls |
| 1 0 0 0 0 | 64 kbit/s | – |
| 1 0 0 0 1 | 2 × 64 kbit/s | – |
| 1 0 0 1 1 | 384 kbit/s | – |
| 1 0 1 0 1 | 1536 kbit/s | – |
| 1 0 1 1 1 | 1920 kbit/s | – |
| 1 1 0 0 0 | Multirate (64 kbit/s base rate) | |

All other values are reserved.

NOTE 1– When the information transfer rate 2 × 64 kbit/s is used, the coding of octets 3 and 4 refer to both 64 kbit/s channels.

NOTE 2 – Additional attributes are defined in Table 4-7.

Rate multiplier (octet 4.1)

NOTE 3 – Coded as a binary representation of the multiplier to the base rate. The multiplier can take any value from 2 up to the maximum number of B-channels available on the interface.

Superseded by a more recent version

TABLE 4-6/Q.931 (cont.)

Bearer capability information element

User information layer 1 protocol (octet 5)

Bits

5 4 3 2 1

- | | |
|-----------|--|
| 0 0 0 0 1 | CCITT standardized rate adaption V.110 and X.30. This implies the presence of octet 5a and optionally octets 5b, 5c and 5d as defined below. |
| 0 0 0 1 0 | Recommendation G.711 [10] μ -law |
| 0 0 0 1 1 | Recommendation G.711 A-law |
| 0 0 1 0 0 | Recommendation G.721 [11] 32 kbit/s ADPCM and Recommendation I.460. |
| 0 0 1 0 1 | Recommendations H.221 and H.242 |
| 0 0 1 1 1 | Non-CCITT standardized rate adaption. This implies the presence of octet 5a and, optionally, octets 5b, 5c and 5d. The use of this code point indicates that the user rate specified in octet 5a is defined by the user. Additionally, octets 5b, 5c and 5d, if present, are defined consistent with the user specified rate adaption. |
| 0 1 0 0 0 | CCITT standardized rate adaption V.120 [9]. This implies the presence of octets 5a and 5b as defined below, and optionally octets 5c and 5d. |
| 0 1 0 0 1 | CCITT standardized rate adaption X.31 [14] HDLC flag stuffing. |

All other values are reserved.

NOTE – If the transfer mode is “circuit mode”, and if the information transfer capability is “unrestricted digital information” or “restricted digital information”; and if the user information layer 1 protocol is to be identified only to the addressed entity octet 5 shall be omitted. If the transfer mode is packet mode, octet 5 may be omitted. Otherwise, octet 5 shall be present.

Synchronous/Asynchronous (octet 5a)

Bit

7

- | | |
|---|-------------------|
| 0 | Synchronous data |
| 1 | Asynchronous data |

NOTE 1 – Octets 5b – 5d may be omitted in the case of synchronous user rates.

Negotiation (octet 5a)

- | | | |
|------|---|----------------------------------|
| Bits | 0 | In-band negotiation not possible |
| | 1 | In-band negotiation not possible |

NOTE 2 – See Recommendations V.110 [7] and X.30 [8] or modem type recommendation

Superseded by a more recent version

TABLE 4-6/Q.931 (cont.)

Bearer capability information element

User rate (octet 5a)

Bits

5 4 3 2 1

0 0 0 0 0	Rate is indicated by E-bits specified in Recommendation I.460 [15] or may be negotiated in-band
0 0 0 0 1	0.6 kbit/s Recommendations V.6 [16] and X.1 [17]
0 0 0 1 0	1.2 kbit/s Recommendation V.6
0 0 0 1 1	2.4 kbit/s Recommendations V.6 and X.1
0 0 1 0 0	3.6 kbit/s Recommendation V.6
0 0 1 0 1	4.8 kbit/s Recommendations V.6 and X.1
0 0 1 1 0	7.2 kbit/s Recommendation V.6
0 0 1 1 1	8 kbit/s Recommendation I.460
0 1 0 0 0	9.6 kbit/s Recommendations V.6 and X.1
0 1 0 0 1	14.4 kbit/s Recommendation V.6
0 1 0 1 0	16 kbit/s Recommendation I.460
0 1 0 1 1	19.2 kbit/s Recommendation V.6
0 1 1 0 0	32 kbit/s Recommendation I.460
0 1 1 1 0	48 kbit/s Recommendations V.6 and X.1
0 1 1 1 1	56 kbit/s Recommendation V.6
1 0 1 0 1	0.1345 kbit/s Recommendation X.1
1 0 1 1 0	0.100 kbit/s Recommendation X.1
1 0 1 1 1	0.075/1.2 kbit/s Recommendations V.6 and X.1 (Note 3)
1 1 0 0 0	1.2/0.075 kbit/s Recommendations V.6 and X.1 (Note 3)
1 1 0 0 1	0.050 kbit/s Recommendations V.6 and X.1
1 1 0 1 0	0.075 kbit/s Recommendations V.6 and X.1
1 1 0 1 1	0.110 kbit/s Recommendations V.6 and X.1
1 1 1 0 0	0.150 kbit/s Recommendations V.6 and X.1
1 1 1 0 1	0.200 kbit/s Recommendations V.6 and X.1
1 1 1 1 0	0.300 kbit/s Recommendations V.6 and X.1
1 1 1 1 1	12 kbit/s Recommendation V.6

All other values are reserved.

NOTE 3 – The first rate is the transmit rate in the forward direction of the call. The second rate is the transmit rate in the backward direction of the call.

Octet 5b for V.110 and X.30 rate adaption

Intermediate rate (octet 5b)

Bits

7 6

0 0	Not used
0 1	8 kbit/s
1 0	16 kbit/s
1 1	32 kbit/s

Superseded by a more recent version

TABLE 4-6/Q.931 (cont.)

Bearer capability information element

<i>Network independent clock (NIC) on transmission (Tx) (octet 5b) (Note 1)</i>	
Bit	
<u>5</u>	
0	Not required to send data with network independent clock
1	Required to send data with network independent clock
NOTE 1 – Refers to transmission in the forward direction of the call.	
NOTE 2 – See Recommendations V.110 [7] and X.30.	
<i>Network independent clock (NIC) on reception (Rx) (octet 5b) (Note 3)</i>	
Bit	
<u>4</u>	
0	Cannot accept data with network independent clock (i.e. sender does not support this optional procedure)
1	Can accept data with network independent clock (i.e. sender does support this optional procedure)
NOTE 3 – Refers to transmission in the backward direction of the call.	
NOTE 4 – See Recommendations V.110 [7] and X.30 [8].	
<i>Flow control on transmission (Tx) (octet 5b) (Note 5)</i>	
Bit	
<u>3</u>	
0	Not required to send data with flow control mechanism
1	Required to send data with flow control mechanism
NOTE 5 – Refers to transmission in the forward direction of the call.	
NOTE 6 – See Recommendations V.110 and X.30.	
<i>Flow control on reception (Rx) (octet 5b) (Note 7)</i>	
Bit	
<u>2</u>	
0	Cannot accept data with flow control mechanism (i.e. sender does not support this optional procedure)
1	Can accept data with flow control mechanism (i.e. sender does support this optional procedure)
NOTE 7 – Refers to transmission in the backward direction of the call	
NOTE 8 – See Recommendations V.110 and X.30.	
<i>Octet 5b for V.120 [9] rate adaption</i>	
<i>Rate adaption header/no header (octet 5b)</i>	
Bit	
<u>7</u>	
0	Rate adaption header not included
1	Rate adaption header included
<i>Multiple frame establishment support in data link (octet 5b)</i>	
Bit	
<u>6</u>	
0	Multiple frame establishment not supported. Only UI frames allowed
1	Multiple frame establishment supported

Superseded by a more recent version

TABLE 4-6/Q.931 (concl.)

Bearer capability information element

<i>Mode of operation (octet 5b)</i>	
Bit	
<u>5</u>	
0	Bit transparent mode of operation
1	Protocol sensitive mode of operation
<i>Logical link identifier negotiation (octet 5b)</i>	
Bit	
<u>4</u>	
0	Default, LLI = 256 only
1	Full protocol negotiation (Note)
NOTE – A connection over which protocol negotiation will be executed is indicated in bit 2 of octet 5b.	
<i>Assignor/assignee (octet 5b)</i>	
Bit	
<u>3</u>	
0	Message originator is “Default assignee”
1	Message originator is “Assignor only”
<i>In-band/out-band negotiation (octet 5b)</i>	
Bit	
<u>2</u>	
0	Negotiation is done with USER INFORMATION messages on a temporary signalling connection
1	Negotiation is done in-band using logical link zero
<i>Number of stop bits (octet 5c)</i>	
Bits	
<u>7 6</u>	
0 0	Not used
0 1	1 bit
1 0	1.5 bits
1 1	2 bits
<i>Number of data bits excluding parity Bit if present (octet 5c)</i>	
Bits	
<u>5 4</u>	
0 0	Not used
0 1	5 bits
1 0	7 bits
1 1	8 bits
<i>Parity information (Octet 5c)</i>	
Bits	
<u>3 2 1</u>	
0 0 0	Odd
0 1 0	Even
0 1 1	None
1 0 0	Forced to 0
1 0 1	Forced to 1
All other values are reserved.	

Superseded by a more recent version

TABLE 4-6/Q.931 (concl.)

Bearer capability information element

Mode duplex (octet 5d)

Bit

7

0 Half duplex

1 Full duplex

Modem type (octet 5d)

Bits

6 5 4 3 2 1

0 0 0 0 0 0
through national use

0 0 0 1 0 1

0 1 0 0 0 1 Recommendation V.21 [55]

0 1 0 0 1 0 Recommendation V.22 [56]

0 1 0 0 1 1 Recommendation V.22 bis [57]

0 1 0 1 0 0 Recommendation V.23 [58]

0 1 0 1 0 1 Recommendation V.26 [59]

0 1 0 1 1 0 Recommendation V.26 bis [60]

0 1 0 1 1 1 Recommendation V.26 ter [61]

0 1 1 0 0 0 Recommendation V.27 [62]

0 1 1 0 0 1 Recommendation V.27 bis [63]

0 1 1 0 1 0 Recommendation V.27 ter [64]

0 1 1 0 1 1 Recommendation V.29 [65]

0 1 1 1 0 1 Recommendation V.32 [66]

1 0 0 0 0 0
through national use

1 0 1 1 1 1

1 1 0 0 0 0
through user specified

1 1 1 1 1 1

All other values reserved.

User information layer 2 protocol (octet 6)

Bits

5 4 3 2 1

0 0 0 1 0 Recommendation Q.921/I.441 [3]

0 0 1 1 0 Recommendation X.25 [5], link layer

All other values are reserved.

NOTE 1 – If the transfer mode is “packet mode”, octet 6 shall be present. For other cases, if the user layer 2 protocol is to be identified to the network, then octet 6 shall be present; otherwise octet 6 shall be omitted.

User information layer 3 protocol (octet 7)

Bits

5 4 3 2 1

0 0 0 1 0 Recommendation Q.931/I.451

0 0 1 1 0 Recommendation X.25, packet layer

All other values are reserved.

NOTE 2 – If the user information layer 3 protocol is to be identified to the network, octet 7 shall be present; otherwise octet 7 shall be omitted.

Superseded by a more recent version

TABLE 4-7/Q.931

Bearer capability attributes

BC Attributes		Additional Attributes			
Transfer mode	Information transfer capability	Structure	Configuration	Establishment	Symmetry
Circuit	Speech	8 kHz integrity	Point-to-point	Demand	Bi-directional symmetric
Circuit	Unrestricted data	8 kHz integrity	Point-to-point	Demand	Bi-directional symmetric
Circuit	Restricted data	8 kHz integrity	Point-to-point	Demand	Bi-directional symmetric
Circuit	3,1 kHz audio	8 kHz integrity	Point-to-point	Demand	Bi-directional symmetric
Circuit	Unrestricted data with tones/-announcements	8 kHz integrity	Point-to-point	Demand	Bi-directional symmetric
Circuit	Video	8 kHz integrity	Point-to-point	Demand	Bi-directional symmetric
Packet	Unrestricted data	Service data unit integrity	Point-to-point	Demand	Bi-directional symmetric

NOTES

- When the information transfer rate 2×64 kbit/s is used, 8 kHz integrity with Restricted Differential Time Delay (RDTD) is offered.
- When multirate (64 kbit/s base rate) is indicated as the information transfer rate, Time Slot Sequence integrity shall be provided.

4.5.6 Call identity

The purpose of the Call identity information element is to identify the suspended call. The call identity provided by the user is guaranteed by the network to be unique over the user-network interface on which the user resides. The call identity is assigned at the start of the call suspension, and is available for re-use after the resume procedure has completed successfully.

The Call identity information element is coded as shown in Figure 4-12.

The default maximum length of this information element is ten octets.

4.5.7 Call state

The purpose of the Call state information element is to describe the current status of a call, (see 2.1) or an access-connection (see 2.2) or a global interface state (see 2.4).

The Call state information element is coded as shown in Figure 4-13 and Table 4-8.

The length of this information element is three octets.

Superseded by a more recent version

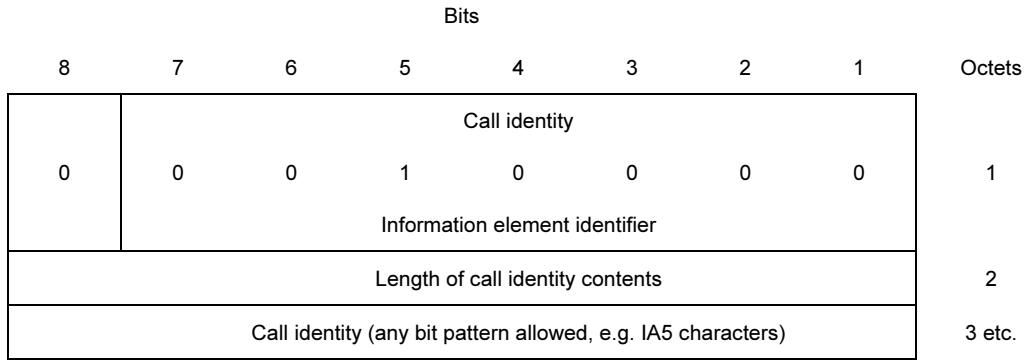

FIGURE 4-12/Q.931

Call identity information element

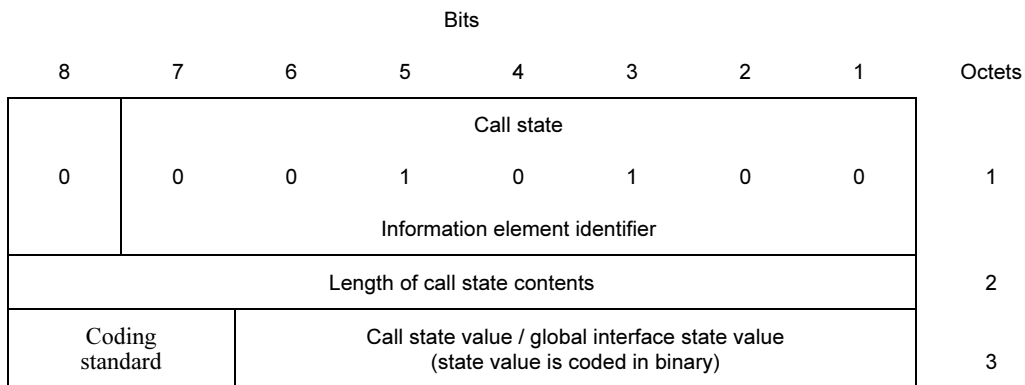

FIGURE 4-13/Q.931

Call state information element

Superseded by a more recent version

TABLE 4-8/Q.931

Call state information element

<i>Coding standard (octet 3)</i>		
Bits		
<u>8 7</u>		
0 0	CCITT standardized coding, as described below	
0 1	ISO/IEC standard (Note)	
1 0	National standard (Note)	
1 1	Standard defined for the network (either public or private) present on the network side of the interface (Note)	
NOTE – These other coding standards should only be used only when the desired call states cannot be represented by CCITT-standardized coding.		
<i>Call state value (octet 3)</i>		
Bits		
<u>6 5 4 3 2 1</u>	<i>User State</i>	<i>Network state</i>
0 0 0 0 0 0	U0 – Null	N0 – Null
0 0 0 0 0 1	U1 – Call initiated	N1 – Call initiated
0 0 0 0 1 0	U2 – Overlap sending	N2 – Overlap sending
0 0 0 0 1 1	U3 – Outgoing call proceeding	N3 – Outgoing call proceeding
0 0 0 1 0 0	U4 – Call delivered	N4 – Call delivered
0 0 0 1 1 0	U6 – Call present	N6 – Call present
0 0 0 1 1 1	U7 – Call received	N7 – Call received
0 0 1 0 0 0	U8 – Connect request	N8 – Connect request
0 0 1 0 0 1	U9 – Incoming call proceeding	N9 – Incoming call proceeding
0 0 1 0 1 0	U10 – Active	N10 – Active
0 0 1 0 1 1	U11 – Disconnect request	N11 – Disconnect request
0 0 1 1 0 0	U12 – Disconnect indication	N12 – Disconnect indication
0 0 1 1 1 1	U15 – Suspend request	N15 – Suspend request
0 1 0 0 0 1	U17 – Resume request	N17 – Resume request
0 1 0 0 1 1	U19 – Release request	N19 – Release request
0 1 0 1 1 0	-----	N22 – Call abort
0 1 1 0 0 1	U25 – Overlap receiving	N25 – Overlap receiving
<i>Global interface state value (octet 3)</i>		
Bits		
<u>6 5 4 3 2 1</u>	State	
0 0 0 0 0 0	REST0 – Null	
1 1 1 1 0 1	REST1 – Restart request	
1 1 1 1 1 0	REST2 – Restart	
All other values are reserved.		

Superseded by a more recent version

4.5.8 Called party number

The purpose of the Called party number information element is to identify the called party of a call.

The Called party number information element is coded as shown in Figure 4-14 and Table 4-9.

The maximum length of this information element is network dependent.

Bits								Octets
8	7	6	5	4	3	2	1	
Called party number-								1
0	1	1	1	0	0	0	0	
Information element identifier								
Length of called party number contents								2
1 Ext.	Type of number			Numbering plan identification				3
0	Number digits (IA5 characters) (Note)							4 etc.

NOTE – The number digits appear in multiple octet 4's in the same order in which they would be entered, that is, the number digit which would be entered first is located in the first octet 4.

FIGURE 4-14/Q.931

Called party number information element

Superseded by a more recent version

TABLE 4-9/Q.931

Called party number information element

Type of number (octet 3) (Note 1)

Bits

7 6 5

0 0 0	Unknown (Note 2)
0 0 1	International number (Note 3)
0 1 0	National number (Note 3)
0 1 1	Network specific number (Note 4)
1 0 0	Subscriber number (Note 3)
1 1 0	Abbreviated number (Note 5)
1 1 1	Reserved for extension

All other values are reserved.

NOTE 1 – For the definition of international, national and subscriber number, see Recommendation I.330 [18].

NOTE 2 – The type of number “unknown” is used when the user or the network has no knowledge of the type of number, e.g. international number, national number, etc. In this case the number digits field is organized according to the network dialling plan, e.g. prefix or escape digits might be present.

NOTE 3 – Prefix or escape digits shall not be included.

NOTE 4 – The type of number “network specific number” is used to indicate administration/service number specific to the serving network, e.g. used to access an operator.

NOTE 5 – The support of this code is network dependent. The number provided in this information element presents a shorthand representation of the complete number in the specified numbering plan as supported by the network.

Numbering plan identification (octet 3)

Numbering plan (applies for type of number = 000, 001, 010 and 100)

Bits

4 3 2 1

0 0 0 0	Unknown (Note 6)
0 0 0 1	ISDN/telephony numbering plan (Recommendation E.164 [19])
0 0 1 1	Data numbering plan (Recommendation X.121 [21])
0 1 0 0	Telex numbering plan (Recommendation F.69 [22])
1 0 0 0	National standard numbering plan
1 0 0 1	Private numbering plan
1 1 1 1	Reserved for extension

All other values are reserved.

NOTE 6 – The numbering plan “unknown” is used when the user or network has no knowledge of the numbering plan. In this case the number digits field is organized according to the network dialling plan, e.g. prefix or escape digits might be present.

Number digits (octets 4, etc.)

This field is coded with IA5 characters, according to the formats specified in the appropriate numbering/dialling plan.

Superseded by a more recent version

4.5.9 Called party subaddress

The purpose of the Called party subaddress information element is to identify the subaddress of the called party of the call. The network does not interpret this information. For the definition of subaddress see Recommendation I.330 [18].

The Called party subaddress information element is coded as shown in Figure 4-15 and Table 4-10.

The maximum length of this information element is 23 octets.

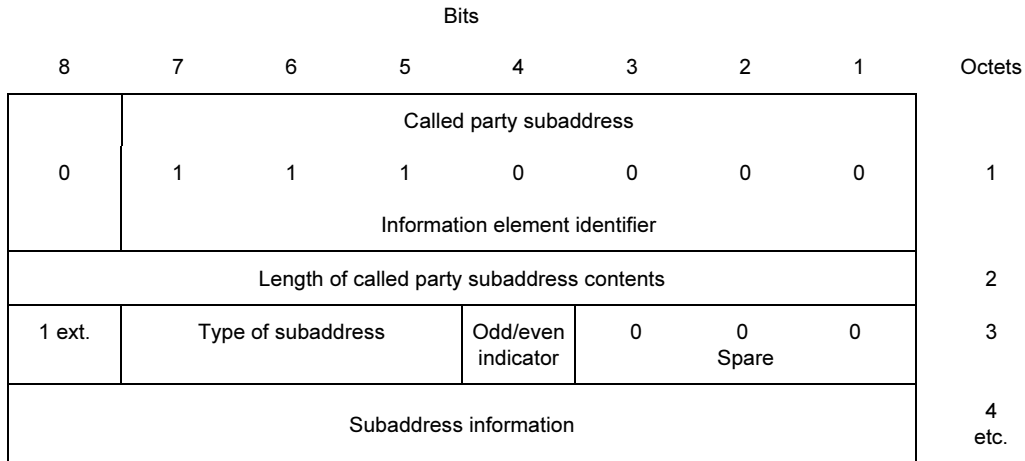

FIGURE 4-15/Q.931

Called party subaddress information element

Superseded by a more recent version

TABLE 4-10/Q.931

Called party subaddress information element

<i>Type of subaddress (octet 3)</i>	
Bits	
<u>7</u> <u>6</u> <u>5</u>	
0 0 0	NSAP (CCITT Rec. X.213 [23]/ISO 8348 AD2 [24])
0 1 0	User specified
All other values are reserved.	
<i>Odd/even indicator (octet 3)</i>	
Bit	
<u>4</u>	
0	Even number of address signals
1	Odd number of address signals
NOTE 1 – The odd/even indicator is used when the type of subaddress is “user specified” and the coding is BCD.	
<i>Subaddress information (octets 4, etc.)</i>	
The NSAP X.213/ISO8348AD2 address, shall be formatted as specified by octet 4 which contains the Authority and Format Identifier (AFI). The encoding is made according to the “preferred binary encoding” as defined in CCITT Rec. X.213/ISO 8348 AD2 except when used for Terminal selection at the S interface (see Note 3). For the definition of this type of subaddress, see Recommendation I.334 [25].	
For user specified subaddress, this field is encoded according to the user specification, subject to a maximum length of 20 octets. When interworking with X.25 [5] networks BCD coding should be applied.	
NOTE 2 – It is recommended that users apply the NSAP subaddress type since this subaddress type allows the use of decimal, binary and IA5 syntaxes in a standardized manner.	
NOTE 3 – It is recommended that users apply the Local IDI format (the AFI field coded 50 in BCD) when the subaddress is used for terminal selection purposes at the S interface. In this case the IA5 character syntax using only digits 0 to 9 shall be used for the DSP. Each character is then encoded in one octet according to Recommendation T.50/ISO 646, with zero parity in the most significant position.	

Superseded by a more recent version

4.5.10 Calling party number

The purpose of the Calling party number information element is to identify the origin of a call.

The Calling party number information element is coded as shown in Figure 4-16, and Table 4-11.

The maximum length of this information element is network dependent.

Bits								Octets
8	7	6	5	4	3	2	1	
Calling party number								1
0	1	1	0	1	1	0	0	
Information element identifier								
Length of calling party number contents								2
0/1 ext.	Type of number			Numbering plan identification				3
1 ext.	Presentation indicataor	0	0	0	Spare		Screening indicator	3a*
0	Number digits (IA5 characters)							4*

FIGURE 4-16/Q.931

Calling party number information element

Superseded by a more recent version

TABLE 4-11/Q.931

Calling party number information element

Type of number (octet 3) (Note 1)

Bits

7 6 5

0 0 0	Unknown (Note 2)
0 0 1	International number (Note 3)
0 1 0	National number (Note 3)
0 1 1	Network specific number (Note 4)
1 0 0	Subscriber number (Note 3)
1 1 0	Abbreviated number (Note 5)
1 1 1	Reserved for extension

All other values are reserved.

NOTE 1 – For the definition of international, national and subscriber number, (see Recommendation I.330 [18]).

NOTE 2 – The type of number “unknown” is used when the user or the network has no knowledge of the type of number, e.g. international number, national number, etc. In this case the number digits field is organized according to the network dialling plan; e.g. prefix or escape digits might be present.

NOTE 3 – Prefix or escape digits shall not be included.

NOTE 4 – The type of number “network specific number” is used to indicate administration/service number specific to the serving network, e.g. used to access an operator.

NOTE 5 – The support of this code is network dependent. The number provided in this information element presents a shorthand representation of the complete number in the specified numbering plan as supported by the network.

Numbering plan identification (octet 3)

Numbering plan (applies for type of number = 000, 001, 010 and 100)

Bits

4 3 2 1

0 0 0 0	Unknown (Note 6)
0 0 0 1	ISDN/telephony numbering plan (Recommendation E.164 [19])
0 0 1 1	Data numbering plan (Recommendation X.121 [21])
0 1 0 0	Telex numbering plan (Recommendation F.69 [22])
1 0 0 0	National standard numbering plan
1 0 0 1	Private numbering plan
1 1 1 1	Reserved for extension

All other values are reserved.

NOTE 6 – The numbering plan “unknown” is used when the user or network has no knowledge of the numbering plan. In this case the number digits field is organized according to the network dialling plan. e.g. prefix or escape digits might be present.

Superseded by a more recent version

TABLE 4-11/Q.931 (concluded)

Calling party number information element

<i>Presentation indicator (octet 3a)</i>	
Bits	
<u>7 6</u>	Meaning
0 0	Presentation allowed
0 1	Presentation restricted
1 0	Number not available due to interworking
1 1	Reserved
NOTE 1 – The meaning and the use of this field is defined in 3/Q.951 and 4/Q.951.	
<i>Screening indicator (octet 3a)</i>	
Bits	
<u>2 1</u>	Meaning
0 0	User-provided, not screened
0 1	User-provided, verified and passed
1 0	User-provided, verified and failed
1 1	Network provided
NOTE 2 – The meaning and the use of this field is defined in 3/Q.951 and 4/Q.951.	
<i>Number digits (octets 4, etc.)</i>	
This field is coded with IA5 characters, according to the formats specified in the appropriate numbering/dialling plan.	

4.5.11 Calling party subaddress

The purpose of the Calling party subaddress information element is to identify a subaddress associated with the origin of a call. For the definition of subaddress, see Recommendation I.330 [21].

The Calling party subaddress information element is coded as shown in Figure 4-17 and Table 4-12.

The maximum length of this information element is 23.

Superseded by a more recent version

Bits								Octets	
8	7	6	5	4	3	2	1		
Calling party subaddress								1	
0	1	1	0	1	1	0	1		
Information element identifier									
Length of calling party subaddress contents								2	
1 ext.	Type of subaddress		Odd/even indicator	0	0	Spare		0	3
Subaddress information								4 etc.	

FIGURE 4-17/Q.931

Calling party subaddress information element

TABLE 4-12/Q.931

Calling party subaddress information element

<p><i>Type of subaddress (octet 3)</i></p> <p>Bits</p> <p><u>7 6 5</u></p> <p>0 0 0 NSAP(CCITT Rec. X.213 [23]/ISO 8348 AD2 [24])</p> <p>0 1 0 User specified</p> <p>All other values are reserved.</p> <p><i>Odd/even indicator (octet 3)</i></p> <p>Bit</p> <p><u>4</u></p> <p>0 Even number of address signals</p> <p>1 Odd number of address signals</p> <p>NOTE 1 – The odd/even indicator is used when the type of subaddress is “user specified” and the coding is BCD.</p> <p><i>Subaddress information (octets 4, etc.)</i></p> <p>The NSAP CCITT Rec. X.213/ISO 8348 AD2 address, shall be formatted as specified by octet 4 which contains the Authority and Format Identifier (AFI). The encoding is made according to the “preferred binary encoding” as defined in CCITT Rec. X.213/ISO 8348 AD2 except when used for Terminal selection at the S interface (see Note 3). For the definition of this type of subaddress, see Recommendation I.334 [25].</p> <p>For user specified subaddress, this field is encoded according to the user specification, subject to a maximum length of 20 octets. When interworking with X.25 [5] networks BCD coding should be applied.</p> <p>NOTE 2 – It is recommended that users apply the NSAP subaddress type since this subaddress type allows the use of decimal, binary and IA5 syntaxes in a standardized manner.</p> <p>NOTE 3 – It is recommended that users apply the Local IDI format (the AFI field coded 50 in BCD) when the subaddress is used for terminal selection purposes at the S interface. In this case the IA5 character syntax using only digits 0 to 9 shall be used for the DSP. Each character is then encoded in one octet according to CCITT Rec. T.50/ISO 646, with zero parity in the most significant position.</p>
--

Superseded by a more recent version

4.5.12 Cause

The content and use of the Cause information element is defined in Recommendation Q.850 [67].

4.5.13 Channel identification

The purpose of the Channel identification information element is to identify a channel within the interface(s) controlled by these signalling procedures.

The Channel identification information element is coded as shown in Figures 4-18 and 4-19 and Table 4-13. The channel identification element may be repeated in a message, e.g. to list several acceptable channels during channel negotiation.

The default maximum length for this information element is network dependent.

Bits							Octets	
8	7	6	5	4	3	2		1
Channel identification							1	
0	0	0	1	1	0	0		0
Information element identifier								
Length of channel identification contents							2	
1 ext.	Int. id. present	Int. type	0 spare	Pref./Excl.	D-channel ind.	Info. channel selection		3
0/1 ext.	Interface identifier						3.1*, etc. (Note 1)	
1 ext.	Coding standard		Number/ Map	Channel type/Map element type			3.2* (Note 2) (Note 5)	
Channel number/Slot map (Note 3)							3.3* (Note 2) (Note 4) (Note 5)	
NOTES								
1 When the "interface identifier present" field in octet 3 indicates "interface implicitly identified" octet 3.1 is omitted. When octet 3.1 is present it may be extended by using the extension bit (bit 8).								
2 When the "interface type" field in octet 3 indicates "basic interface", octets 3.2 and 3.3 are functionally replaced by the "information channel selection" field in octet 3, and thus omitted.								
3 When channel number is used and a single channel is indicated bit 8 shall be set to "1". When channel number is used and multiple channels are indicated, bit 8 shall be used as an extension bit to indicate an extension to subsequent channels and coded according to the rules specified in 4.5.1.								
4 When channel number is used, this octet may be repeated to indicate multiple channels.								
5 These octets shall be omitted when the entire interface is to be identified.								

FIGURE 4-18/Q.931

Channel identification information element

Superseded by a more recent version

TABLE 4-13/Q.931

Channel identification information element

<i>Interface identifier present (octet 3)</i>		
Bit		
<u>7</u>		
0	Interface implicitly identified (Note 1)	
1	Interface explicitly identified in one or more octets, beginning with octet 3.1.	
NOTE 1 – The interface which includes the D-channel carrying this information element is indicated.		
<i>Interface type (octet 3)</i>		
Bit		
<u>6</u>		
0	Basic interface	
1	Other interface e.g. primary rate (Note 2)	
NOTE 2 – The type of interface should be understood because the interface is identified by the “interface identifier present” field (octet 3, bit 7) and the interface identifier field (octet 3.1), if any.		
<i>Preferred/Exclusive (octet 3)</i>		
Bit		
<u>4</u>		
0	Indicated channel is preferred	
1	Exclusive; only the indicated channel is acceptable	
NOTE 3 – Preferred/exclusive has significance only for B-channel selection.		
<i>D-channel indicator (octet 3)</i>		
Bit		
<u>3</u>		
0	The channel identified is not the D-channel	
1	The channel identified is the D-channel	
NOTE 4 – D-channel indication has significance in D-channel use. No other information affects D-channel use.		
<i>Information channel selection (octet 3) (Note 5)</i>		
	<i>Basic interface</i>	<i>Other interfaces</i>
<i>Bits</i>		
<u>2 1</u>		
0 0	No channel	No channel
0 1	B1 channel	As indicated in following octets
1 0	B2 channel	Reserved
1 1	Any channel (Note 6)	Any channel
NOTE 5 – The information channel selection does not apply to the D-channel.		
NOTE 6 – This value shall be used on a basic access when both B-channels are to be identified, e.g. multirate (64 kbit/s base rate). This shall not be used for restart procedures.		

Superseded by a more recent version

TABLE 4-13/Q.931 (concluded)

Channel identification information element

<i>Interface identifier (octet 3.1)</i>	
Binary code assigned to the interface at subscription time. At subscription time, the binary code for the interface will specify the number of octets to be used and the content of each octet.	
<i>Coding standard (octet 3.2)</i>	
Bits	
<u>7 6</u>	
0 0	CCITT standardized coding, as described below
0 1	ISO/IEC standard (Note 1)
1 0	National standard (Note 1)
1 1	Standard defined for the network (either public or private) present on the network side of the interface (Note 1)
NOTE 1 – These other coding standards should only be used when the desired call states cannot be represented by CCITT-standardized coding.	
<i>Number/map (octet 3.2)</i>	
Bit	
<u>5</u>	
0	Channel is indicated by the number in the following octet.
1	Channel is indicated by the slot map (Map) in the following octet(s).
NOTE 2 – When the information transfer rate is 64 kbit/s the channel number shall be used unless there exists a bilateral agreement between the user and the network to use the slot map.	
NOTE 3 – Slot map shall be used when supporting the multirate (64 kbit/s base rate) bearer capability on a primary rate access.	
<i>Channel type/map element type (octet 3.2)</i>	
Bits	
<u>4 3 2 1</u>	
0 0 1 1	B-channel units(Note 4)
0 1 1 0	H0-channel units
1 0 0 0	H11-channel units
1 0 0 1	H12-channel units
All other values are reserved.	
NOTE 4 – This value shall be used for multirate (64 kbit/s base rate) bearer capability.	
<i>Channel number (octet 3.3)</i>	
Binary number assigned to the channel. For B-channels, the channel number equals the time slot number. See Recommendation I.431 [27].	
NOTE 1 – Either “Channel Number” or “Slot map” is used exclusively, depending on the “Number/Map” information.	
<i>Slot map (octet 3.3)</i>	
Bit position(s) in slot map corresponding to time slot(s) used by the channel is set to 1, see Figure 4-19. The remaining bits are set to 0.	
NOTE 2 – The length of the slot-map (in bits) is defined by the capacity of the interface type (e.g. 1534 kbit/s or 2048 kbit/s for a primary rate interface) divided by the capacity of the channel type/map-element type (e.g. 64 kbit/s for a B-channel). The length of the slot map is the smallest number of complete octets that contain the length in bits.	

Superseded by a more recent version

Bits								Octets
8	7	6	5	4	3	2	1	
24	23	22	21	20	19	18	17	3.3.1
16	15	14	13	12	11	10	9	3.3.2
8	7	6	5	4	3	2	1	3.3.3

1544 kbit/s

Bits								Octets
8	7	6	5	4	3	2	1	
31	30	29	28	27	26	25	24	3.3.1
23	22	21	20	19	18	17	16	3.3.2
15	14	13	12	11	10	9	8	3.3.3
7	6	5	4	3	2	1	0	3.3.4

2048 kbit/s

a) Primary rate interface, map element type = B channel

Bits								Octets
8	7	6	5	4	3	2	1	
				d(4)	c(3)	b(2)	a(1)	3.3

1544 kbit/s

Bits								Octets
8	7	6	5	4	3	2	1	
			e(5)	d(4)	c(3)	b(2)	a(1)	3.3

2048 kbit/s

b) Primary rate interface, map element type = H₀ channel

NOTE 1 – See Recommendation I.431 [27], Annex A, concerning meaning of a-e.

NOTE 2 – Number within () indicates the associated H₀-channel number used when corresponding H₀-channel is represented by channel number in octet 3.3.

Bits								Octet
8	7	6	5	4	3	2	1	
							H11(1)	3.3

1544 kbit/s

Bits								Octet
8	7	6	5	4	3	2	1	
							H12(1)	3.3

2048 kbit/s

c) Primary rate interface, map element type = H₁-channel

NOTE 3 – Number within () indicates the associated H₁-channel number used when corresponding H₁-channel is represented by channel number in octet 3.3.

NOTE 4 – For 2048 kbit/s interface, H₁₁ slot will be indicated by the same format.

FIGURE 4-19/Q.931

Slot map field

Superseded by a more recent version

4.5.14 Congestion level

The purpose of the Congestion level information element is to describe the congestion status of the call. It is a single octet information element coded as shown in Figure 4-20 and Table 4-14.

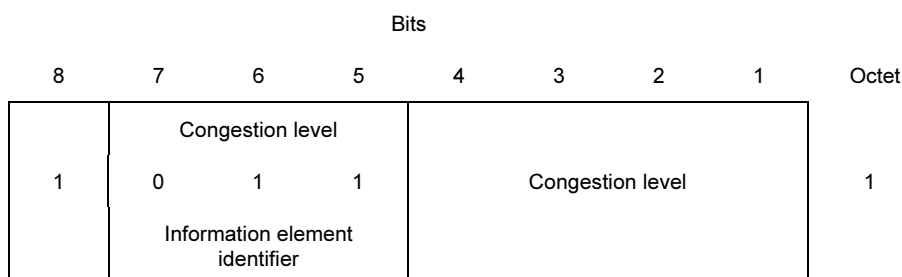

FIGURE 4-20/Q.931

Congestion level information element

TABLE 4-14/Q.931

Congestion level information element

Congestion level (octet 1)	
Bits	
4 3 2 1	
0 0 0 0	receiver ready
1 1 1 1	receiver not ready
All other values are reserved.	

4.5.15 Date/time

The purpose of the Date/time information element is to provide the date and time to the user. It indicates the point in time when the message has been generated by the network.

NOTE – It is a network dependent matter whether the time indicated is local time or Coordinated Universal Time (UTC) and which calendar is used for referencing the date.

The Date/time information element is coded as shown in Figure 4-21.

Superseded by a more recent version

Bits								Octets
8	7	6	5	4	3	2	1	
0	0	1	0	1	0	0	1	1
Date/time Information element identifier								
Length of date/time contents								2
Year								3
Month								4
Day								5
Hour								6*
Minute								7*
Second								8*

NOTE – Octets 3-8 are binary coded (bit 1 being the least significant bit).

FIGURE 4-21/Q.931

Date/time information element

4.5.16 Display

The purpose of the Display information element is to supply display information that may be displayed by the user. The information contained in this element is coded in IA5 characters.

The display information element is coded as shown in Figure 4-22.

The Display information element has a network dependent default maximum length of 34 or 82 octets. The evolution to a single maximum value of 82 octets is an objective. If a user receives a Display information element with a length exceeding the maximum length which the user can handle, the information element should be truncated by the user.

Bits								Octets
8	7	6	5	4	3	2	1	
0	0	1	0	1	0	0	0	1
Display Information element identifier								
Length of display contents								2
0	Display information (IA5 characters)							3 etc.

FIGURE 4-22/Q.931

Display information element

Superseded by a more recent version

4.5.17 High layer compatibility

The purpose of the High layer compatibility information element is to provide a means which should be used by the remote user for compatibility checking. See Annex B.

The High layer compatibility information element is coded as shown in Figure 4-23 and Table 4-15.

The High layer compatibility information element can be repeated in the SETUP message to indicate dual high layer capabilities for selection. By default, if the High layer compatibility information element is repeated without the Repeat indicator information element, it shall be interpreted as increasing order of priority.

The maximum length of this information element is five octets.

NOTE – The High layer compatibility information element is transported transparently by an ISDN between a call originating entity, e.g. a calling user and the addressed entity, e.g. a remote user or a high layer function network node addressed by the call originating entity. However, if explicitly requested by the user (at subscription time), a network which provides some capabilities to realize teleservices may interpret this information to provide a particular service.

Bits								Octets
8	7	6	5	4	3	2	1	
High layer compatibility								1
0	1	1	1	1	1	0	1	
Information element identifier								
Length of high layer compatibility contents								2
1 ext.	Coding standard	Interpretation			Presentation method of protocol profile			3
0/1 ext.	High layer characteristics identification							4
1 ext.	Extended high layer characteristics identification							4a* (Note)

NOTE – This octet may be present when octet 4 indicates Maintenance or Management.

FIGURE 4-23/Q.931

High layer compatibility information element

Superseded by a more recent version

TABLE 4-15/Q.931

High layer compatibility information element

Coding standard (octet 3)

Bits	
<u>7</u>	<u>6</u>
0 0	CCITT standardized coding, as described below
0 1	ISO/IEC standard (Note 1)
1 0	National standard (Note 1)
1 1	Standard defined for the network (either public or private) present on the network side of the interface (Note 1)

NOTE 1 – These other coding standards should only be used only when the desired high layer compatibility cannot be represented by CCITT standardized coding.

Interpretation (octet 3)

Bits		
<u>5</u>	<u>4</u>	<u>3</u>
1 0 0	First (primary or only) high layer characteristics identification (in octet 4) to be used in the call	

All other values are reserved.

NOTE 2 – “Interpretation” indicates how the “High layer characteristics identification” (in octet 4) should be interpreted.

NOTE 3 – Currently, “Interpretation” has only a single value. However, “Interpretation”, when enhanced, will be able to indicate how the “High layer characteristics identification” in the same information element shall be interpreted when multiple “High layer characteristics identifications” are used and exact relationship among them needs to be indicated (e.g. sequential usage, alternative list, simultaneous usage). Such enhancements in conjunction with the possible negotiation procedures are left for further study.

Presentation method of protocol profile (octet 3)

Bits	
<u>2</u>	<u>1</u>
0 1	High layer protocol profile (without specification of attributes)

All other values are reserved.

NOTE 4 – Currently, “Presentation method of protocol profile” has only a single value, i.e. a “profile value” is used to indicate a service to be supported by high layer protocols as required. Necessity of other presentation methods, e.g. service indications in the forum of layer-by-layer indication of protocols to be used in high layers, is left for further study.

High layer characteristics identification (octet 4)

Bits						
<u>7</u>	<u>6</u>	<u>5</u>	<u>4</u>	<u>3</u>	<u>2</u>	<u>1</u>
0 0 0 0 0 0 1	Telephony					
0 0 0 0 1 0 0	Facsimile Group 2/3 (Recommendation F.182 [68])					
0 1 0 0 0 0 1	Facsimile Group 4 Class I (Recommendation F.184 [69])					
0 1 0 0 1 0 0	Teletex service, basic and mixed mode of operation (Recommendation F.230 [70]) and facsimile service Group 4, Classes II and III (Recommendation F.184)					
0 1 0 1 0 0 0	Teletex service, basic and processable mode of operation (Recommendation F.220 [71])					
0 1 1 0 0 0 1	Teletex service, basic mode of operation (Recommendation F.200 [72])					
0 1 1 0 0 1 0	Syntax based Videotex (Recommendations F.300 [73] and T.102 [74])					
0 1 1 0 0 1 1	International Videotex interworking via gateways or interworking units (Recommendations F.300 and T.101 [75])					
0 1 1 0 1 0 1	Telex service (Recommendation F.60 [76])					
0 1 1 1 0 0 0	Message Handling Systems (MHS) (X.400 - Series Recommendations [77])					
1 0 0 0 0 0 1	OSI application (Note 2) (X.200 - Series Recommendations [78])					
1 0 1 1 1 1 0	Reserved for maintenance (Note 4)					
1 0 1 1 1 1 1	Reserved for management (Note 4)					
1 1 0 0 0 0 0	Audio visual (Recommendation F.721 [79])					
1 1 0 0 0 0 1	Reserved for audiovisual services (F.700 - Recommendations Series [80])					
through	1 1 0 1 1 1 1					
	1 1 1 1 1 1 1	Reserved				

Superseded by a more recent version

TABLE 4-15/Q.931 (continued)

High layer compatibility information element

All other values are reserved.

NOTES

- 1 The coding above applies in case of "Coding standard" = "CCITT standard" and "Presentation method of protocol profile" = "High layer protocol profile".
- 2 Further compatibility checking will be executed by the OSI high layer protocol.
- 3 Code points are added only to those services for which CCITT Recommendations are available. See also Recommendation I.241 [34].
- 4 When this coding is included, octet 4 may be followed by octet 4a.

Extended high layer characteristics identification (octet 4a)

Bits

7 6 5 4 3 2 1

0 0 0 0 0 0 1	Telephony
0 0 0 0 1 0 0	Facsimile Group 2/3 (Recommendation F.182)
0 1 0 0 0 0 1	Facsimile Group 4 Class I (Recommendation F.184)
0 1 0 0 1 0 0	Teletex service, basic and mixed mode of operation (Recommendation F.230) and facsimile service Group 4, Classes II and III (Recommendation F.184)
0 1 0 1 0 0 0	Teletex service, basic and processable mode of operation (Recommendation F.220)
0 1 1 0 0 0 1	Teletex service, basic mode of operation (Recommendation F.200)
0 1 1 0 0 1 0	Syntax based Videotex (Recommendations F.300 and T.102)
0 1 1 0 0 1 1	International Videotex interworking via gateways or interworking units (Recommendations F.300 and T.101)
0 1 1 0 1 0 1	Telex service (Recommendation F.60)
0 1 1 1 0 0 0	Message Handling Systems (MHS) (X.400 - Series Recommendations)
1 0 0 0 0 0 1	OSI application (Note 2) (X.200 - Series Recommendations)
1 0 1 1 1 1 0	Not available for assignment
1 0 1 1 1 1 1	Not available for assignment
1 1 0 0 0 0 0	Audio visual (Recommendation F.721)
1 1 0 0 0 0 1	Reserved for audiovisual services (F.700 - Series Recommendations)
through	
1 1 0 1 1 1 1	
1 1 1 1 1 1 1	Reserved

All other values are reserved.

Superseded by a more recent version

4.5.18 Keypad facility

The purpose of the Keypad facility information element is to convey IA5 characters, e.g. entered by means of a terminal keypad.

The Keypad facility information element is coded as shown in Figure 4-24.

The maximum length of this information element is 34 octets.

8	7	6	5	4	3	2	1	Octets
Keypad facility								
0	0	1	0	1	1	0	0	1
Information element identifier								
Length of the keypad facility contents								2
0	Keypad facility information (IA5 characters)							3 etc.

FIGURE 4-24/Q.931

Keypad facility information element

4.5.19 Low layer compatibility

The purpose of the Low layer compatibility information element is to provide a means which should be used for capability checking by an addressed entity (e.g. a remote user or an interworking unit or a high layer function network node addressed by the calling user). The Low layer compatibility information element is transferred transparently by an ISDN between the call originating entity (e.g. the calling user) and the addressed entity. See Annex B and Annex I.

If low layer compatibility negotiation is allowed by the network (see Annex J), the Low layer compatibility information element is also passed transparently from the addressed entity to originating entity.

The Low layer compatibility information element is coded as shown in Figure 4-25 and Table 4-16. The maximum length of this information element is 18 octets.

NOTE – Some networks conforming to Recommendation Q.931 (1988) may support a maximum information element length of only 16 octets.

Superseded by a more recent version

		Bits									
		8	7	6	5	4	3	2	1	Octets	
0		Low layer compatibility									1
		1	1	1	1	1	1	0	0		
		Information element identifier									
		Length of the low layer compatibility contents									2
0/1 ext.		Coding standard		Information transfer capability							3
1 ext.	Negot. indic.	0	0	0	0	0	0	0	0	3a*	
		Spare									
1 ext.		Transfer mode		Information transfer rate							4
1 ext.		Rate multiplier									4.1* (Note 1)
0/1 ext.		0	1	User information layer 1 protocol							5*
		Layer 1 ident.									
0/1 ext.	Synch./ asynch.	Negot.		User rate							5a* (Note 2)
0/1 ext.		Intermediate rate		NIC on Tx	NIC on Rx	Flow control	Flow control	0 Spare		5b* (Note 3)	
0/1 ext.	Hdr/no Hdr	Multiframe		Mode	Negot. LLI	Assignor/ Assignoree	In-band negot.	0 Spare		5b* (Note 4)	
0/1 ext.		Number of stop bits		Number of data bits		Parity				5c* (Note 2)	
1 ext.	Duplex mode	Modem type								5d* (Note 2)	
0/1 ext.		1	0	User information layer 2 protocol							6*
		layer 2 ident.									
0/1 ext.		Mode		0	0	0	Q.933 use			6a* (Note 5)	
		Spare									
1 ext.		User specified layer 2 protocol information								6a* (Note 6)	
1 ext.		Window size (k)								6b* (Note 5)	
0/1 ext.		1	1	User information layer 3 protocol							7*
		layer 3 ident.									
0/1 ext.		Mode		0	0	0	0	0	0	7a* (Note 7)	
		Spare									
1 ext.		Optional layer 3 protocol information								7a* (Note 8)	
0/1 ext.		0	0	0	Default packet size					7b* (Note 7)	
		Spare									
1 ext.		Packet window size								7c* (Note 7)	

FIGURE 4-25/Q.931

Low layer compatibility information element

Superseded by a more recent version

NOTES to Figure 4-25:

- 1 This octet is required if octet 4 indicates multirate (64 kbit/s base rate). Otherwise, it shall not be present.
- 2 This octet may be present if octet 3 indicates *unrestricted digital information* and octet 5 indicates either of the CCITT standardized rate adaptations V.110 and X.30 or V.120 [9]. It may also be present if octet 3 indicates 3.1 kHz audio and octet 5 indicates G.711.
- 3 This octet is significant only if octet 5 indicates CCITT standardized rate adaptation (V.110 [7] and X.30 [8]).
- 4 This octet is significant only if octet 5 indicates CCITT standardized rate adaptation V.120 [9].
- 5 This octet may be present only if octet 6 indicates certain acknowledged mode HDLC elements of procedure as indicated in Table 4-16.
- 6 This octet may be present only if octet 6 indicates user specified layer 2 protocol.
- 7 This octet may be present only if octet 7 indicates a layer 3 protocol based on CCITT X.25 | ISO/IEC 8208 or CCITT Rec. X.223 | ISO 8878 as indicated in Table 4-16.
- 8 This octet may be present only if octet 7 indicates user specified layer 3 protocol.

Superseded by a more recent version

TABLE 4-16/Q.931

Low layer compatibility information element

Coding standard (octet 3)

bits	
<u>7</u> <u>6</u>	
0 0	CCITT standardized coding, as described below
0 1	ISO/IEC standard (Note 1)
1 0	National standard (Note 1)
1 1	Standard defined for the network (either public or private) present on the network side of the interface (Note 1)

NOTE 1 – These other coding standards should only be used only when the desired low layer compatibility cannot be represented by CCITT-standardized coding.

Information transfer capability (octet 3)

Bits	
<u>5</u> <u>4</u> <u>3</u> <u>2</u> <u>1</u>	
0 0 0 0 0	Speech
0 1 0 0 0	Unrestricted digital information
0 1 0 0 1	Restricted digital information
1 0 0 0 0	3.1 kHz audio
1 0 0 0 1	Unrestricted digital information with tones/announcements (Note 2)
1 1 0 0 0	Video

All other values are reserved.

NOTE 2 – Unrestricted digital information with tones/announcements (UDI-TA) is the new information transfer attribute value that had previously been named “7 kHz audio” in Recommendation Q.931 (1988).

Negotiation indicator (octet 3a)

Bits	
<u>7</u>	
0	Out-band negotiation not possible
1	Out-band negotiation possible

NOTE 3 – See Annex J for description of low layer compatibility negotiation.

NOTE 4 – When octet 3a is omitted, “out-band negotiation not possible” shall be assumed.

Transfer mode (octet 4)

Bits	
<u>7</u> <u>6</u>	
0 0	Circuit mode
1 0	Packet-mode

All other values are reserved.

Information transfer rate (octet 4)

Bits			
<u>5</u> <u>4</u> <u>3</u> <u>2</u> <u>1</u>	Circuit mode	Packet-mode	
0 0 0 0 0	–	This code shall be used for all packet calls	
1 0 0 0 0	64 kbit/s	–	
1 0 0 0 1	2 × 64 kbit/s	–	
1 0 0 1 1	384 kbit/s	–	
1 0 1 0 1	1536 kbit/s	–	
1 0 1 1 1	1920 kbit/s	–	
1 1 0 0 0	Multirate (64 kbit/s base rate)		

All other values are reserved.

NOTE 1 – When the information transfer rate 2 × 64 kbit/s is used the coding of octets 3 and 4 refer to both 64 kbit/s channels.

NOTE 2 – Additional attributes are defined in Table 4-17.

Rate multiplier (octet 4.1)

Coded as a binary representation of the multiplier to the base rate. The multiplier can take any value from 2 up to the maximum number of B-channels available on the interface.

Superseded by a more recent version

TABLE 4-16/Q.931 (continued)

Low layer compatibility information element

User information layer 1 protocol (octet 5)

Bits

5 4 3 2 1

0 0 0 0 1	CCITT standardized rate adaption V.110 [7] and X.30 [8]. This implies the presence of octet 5a and optionally octets 5b, 5c and 5d as defined below.
0 0 0 1 0	Recommendation G.711 [10] μ -law.
0 0 0 1 1	Recommendation G.711 A-law.
0 0 1 0 0	Recommendation G.721 [11] 32 kbit/s ADPCM and Recommendation I.460 [15].
0 0 1 0 1	Recommendations H.221 and H.242.
0 0 1 1 1	Non-CCITT standardized rate adaption. This implies the presence of octet 5a and, optionally, octets 5b, 5c and 5d. The use of this code point indicates that the user rate specified in octet 5a is defined by the user. Additionally, octets 5b, 5c and 5d, if present, are defined consistent with the user specified rate adaption.
0 1 0 0 0	CCITT standardized rate adaption V.120 [9]. This implies the presence of octets 5a and 5b as defined below, and optionally octets 5c and 5d.
0 1 0 0 1	CCITT standardized rate adaption X.31 [14] HDLC flag stuffing.

All other values are reserved.

NOTE 3 – If the transfer mode is “circuit mode” and if the information transfer capability is “unrestricted digital information” or “Restricted digital information”, and if a specific user information layer 1 protocol is to be identified to the addressed entity octet 5 shall be present. If the transfer mode is packet mode, octet 5 may be omitted.

Synchronous/Asynchronous (octet 5a)

Bit

7

0	Synchronous data
1	Asynchronous data

NOTE 1 – Octets 5b-5d may be omitted in the case of synchronous user rates.

Negotiation (octet 5a)

Bit

6

0	In-band negotiation not possible
1	In-band negotiation possible

NOTE 2 – See Recommendations V.110 [7] and X.30 [8] or modem type recommendations.

User rate (octet 5a)

Bits

5 4 3 2 1

0 0 0 0 0	Rate is indicated by E-bits specified in Recommendation I.460 or may be negotiated in-band
0 0 0 0 1	0.6 kbit/s Recommendations V.6 [16] and X.1 [17]
0 0 0 1 0	1.2 kbit/s Recommendation V.6
0 0 0 1 1	2.4 kbit/s Recommendations V.6 and X.1
0 0 1 0 0	3.6 kbit/s Recommendation V.6
0 0 1 0 1	4.8 kbit/s Recommendations V.6 and X.1
0 0 1 1 0	7.2 kbit/s Recommendation V.6
0 0 1 1 1	8 kbit/s Recommendation I.460
0 1 0 0 0	9.6 kbit/s Recommendations V.6 and X.1
0 1 0 0 1	14.4 kbit/s Recommendation V.6
0 1 0 1 0	16 kbit/s Recommendation I.460
0 1 0 1 1	19.2 kbit/s Recommendation V.6
0 1 1 0 0	32 kbit/s Recommendation I.460
0 1 1 1 0	48 kbit/s Recommendations V.6 and X.1
0 1 1 1 1	56 kbit/s Recommendation V.6
1 0 0 0 0	64 kbit/s Recommendation X.1
1 0 1 0 1	0.1345 kbit/s Recommendation X.1
1 0 1 1 0	0.100 kbit/s Recommendation X.1
1 0 1 1 1	0.075/1.2 kbit/s Recommendations V.6 and X.1 (Note 3)
1 1 0 0 0	1.2/0.075 kbit/s Recommendations V.6 and X.1 (Note 3)

Superseded by a more recent version

TABLE 4-16/Q.931 (continued)

Low layer compatibility information element

1 1 0 0 1	0.050 kbit/s Recommendations V.6 and X.1
1 1 0 1 0	0.075 kbit/s Recommendations V.6 and X.1
1 1 0 1 1	0.110 kbit/s Recommendations V.6 and X.1
1 1 1 0 0	0.150 kbit/s Recommendations V.6 and X.1
1 1 1 0 1	0.200 kbit/s Recommendations V.6 and X.1
1 1 1 1 0	0.300 kbit/s Recommendations V.6 and X.1
1 1 1 1 1	12 kbit/s Recommendation V.6

All other values are reserved.

NOTE 3 – The first rate is the transmit rate in the forward direction of the call. The second rate is the transmit rate in the backward direction of the call.

Octet 5b for V.110 [7] and X.30 [8] rate adaptation

Intermediate rate (octet 5b)

Bits	
<u>7</u> <u>6</u>	
0 0	Not used
0 1	8 kbit/s
1 0	16 kbit/s
1 1	32 kbit/s

Network independent clock (NIC) on transmission (Tx) (octet 5b) (Note 1)

Bit	
<u>5</u>	
0	Not required to send data with network independent clock
1	Required to send data with network independent clock

NOTE 1 – Refers to transmission in the forward direction of the call.

NOTE 2 – See Recommendations V.110 and X.30.

Network independent clock (NIC) on reception (Rx) (octet 5b) (Note 3)

Bit	
<u>4</u>	
0	Cannot accept data with Network Independent Clock (i.e. sender does not support this optional procedure)
1	Can accept data with Network Independent Clock (i.e. sender does support this optional procedure)

NOTE 3 – Refers to transmission in the backward direction of the call.

NOTE 4 – See Recommendations V.110 [7] and X.30 [8].

Flow control on transmission (Tx) (octet 5b) (Note 5)

Bit	
<u>3</u>	
0	Not required to send data with flow control mechanism
1	Required to send data with flow control mechanism

NOTE 5 – Refers to transmission in the forward direction of the call.

NOTE 6 – See Recommendations V.110 and X.30.

Flow control on reception (Rx) (octet 5b) (Note 7)

Bit	
<u>2</u>	
0	Cannot accept data with flow control mechanism (i.e. sender does not support this optional procedure)
1	Can accept data with flow control mechanism (i.e. sender does support this optional procedure)

NOTE 7 – Refers to transmission in the backward direction of the call.

NOTE 8 – See Recommendations V.110 and X.30.

Superseded by a more recent version

TABLE 4-16/Q.931 (continued)

Low layer compatibility information element

Octet 5b for V.120 [9] Rate adaption

Rate adaption header/no header (octet 5b)

Bit	
<u>7</u>	
0	Rate adaption header not included
1	Rate adaption header included

Multiple frame establishment support in data link (octet 5b)

Bit	
<u>6</u>	
0	Multiple frame establishment not supported. Only UI frames allowed
1	Multiple frame establishment supported

Mode of operation (octet 5b)

Bit	
<u>5</u>	
0	Bit transparent mode of operation
1	Protocol sensitive mode of operation

Logical link identifier negotiation (octet 5b)

Bit	
<u>4</u>	
0	Default, LLI = 256 only
1	Full protocol negotiation (Note)

NOTE – A connection over which protocol negotiation will be executed is indicated in bit 2 of octet 5b.

Assignor/assignee (octet 5b)

Bit	
<u>3</u>	
0	Message originator is “default assignee”
1	Message originator is “assignor only”

In-band/out-band negotiation (octet 5b)

Bit	
<u>2</u>	
0	Negotiation is done with USER INFORMATION messages on a temporary signalling connection
1	Negotiation is done in-band using logical link zero

Number of stop bits (octet 5c)

Bits	
<u>7 6</u>	
0 0	Not used
0 1	1 bit
1 0	1.5 bits
1 1	2 bits

Number of data bits excluding parity bit if present (octet 5c)

Bits	
<u>5 4</u>	
0 0	Not used
0 1	5 bits
1 0	7 bits
1 1	8 bits

Parity information (octet 5c)

Bits	
<u>3 2 1</u>	
0 0 0	Odd
0 1 0	Even
0 1 1	None
1 0 0	Forced to 0
1 0 1	Forced to 1

All other values are reserved.

Superseded by a more recent version

TABLE 4-16/Q.931 (continued)

Low layer compatibility information element

Duplex mode (octet 5d)

Bit	
7	
0	Half duplex
1	Full duplex

Modem type (octet 5d)

Bits	
6 5 4 3 2 1	
0 0 0 0 0 0	National use
through	
0 0 0 1 0 1	
0 1 0 0 0 1	Recommendation V.21
0 1 0 0 1 0	Recommendation V.22
0 1 0 0 1 1	Recommendation V.22 bis
0 1 0 1 0 0	Recommendation V.23
0 1 0 1 0 1	Recommendation V.26
0 1 0 1 1 0	Recommendation V.26 bis
0 1 0 1 1 1	Recommendation V.26 ter
0 1 1 0 0 0	Recommendation V.27
0 1 1 0 0 1	Recommendation V.27 bis
0 1 1 0 1 0	Recommendation V.27 ter
0 1 1 0 1 1	Recommendation V.29
0 1 1 1 0 0	Recommendation V.32
1 0 0 0 0 0	National use
through	
1 0 1 1 1 1	
1 1 0 0 0 0	User specified
through	
1 1 1 1 1 1	
All other values reserved.	

User information layer 2 protocol (octet 6)

Bits	
5 4 3 2 1	
0 0 0 0 1	Basic mode ISO 1745 [36]
0 0 0 1 0	Recommendation Q.921 (I.441) [3] (Note 4)
0 0 1 1 0	Recommendation X.25 [5], link layer (Notes 1, 4)
0 1 1 1 1	Recommendation X.25 Multilink (Note 4)
0 1 0 0 0	Extended LAPB; for half duplex operation (T.71 [37])
0 1 0 0 1	HDLC ARM (ISO 4335) [38] (Note 4)
0 1 0 1 0	HDLC NRM (ISO 4335) (Note 4)
0 1 0 1 1	HDLC ABM (ISO 4335) (Note 4)
0 1 1 0 0	LAN logical link control (ISO 8802/2) [39]
0 1 1 0 1	Recommendation X.75 [40]. Single Link Procedure (SLP) (Note 4)
0 1 1 1 0	Recommendation Q.922 [] (Note 4)
0 1 1 1 1	Core aspects of Recommendation Q.922
1 0 0 0 0	User specified (Note 2)
1 0 0 0 1	ISO 7776 DTE-DTE operation (Notes 3, 4)
All other values are reserved.	

NOTES

- 1 This Recommendation is compatible with ISO 7776 DTE-DCE operation.
- 2 When this coding is included, octet 6a will include user coding for the user specified Layer 2 protocol.
- 3 This Standard is compatible with Recommendation X.75 modified by the application rules defined in Recommendation T.90.
- 4 When this coding is included, octets 6a and 6b with CCITT encoding may be included.

Superseded by a more recent version

TABLE 4-16/Q.931 (continued)

Low layer compatibility information element

Octet 6a for CCITT codings

Mode of operation (octet 6a)

Bits		
7	6	
0	1	Normal mode of operation
1	0	Extended mode of operation

All other values are reserved.

Q.933 use (octet 6a)

Bits		
2	1	
0	0	For use when the coding defined in Recommendation Q.933 is not used

All other values are reserved.

Octet 6a for user protocol

User specified layer 2 protocol information (octet 6a)

The use and coding of octet 6a is according to user defined requirements.

Window size (k) (octet 6b)

Bits 7-1 binary coding of *k* parameter value in the range from 1 to 127.

User information layer 3 protocol (octet 7)

Bits					
5	4	3	2	1	
0	0	0	1	0	Recommendation Q.931 (I.451)
0	0	1	1	0	Recommendation X.25, packet layer (Note 2)
0	0	1	1	1	ISO/IEC 8208 [41] (X.25 packet level protocol for data terminal equipment) (Note 2)
0	1	0	0	0	CCITT Rec. X.223 ISO 8878 [81] (use of ISO/IEC 8208 [41] and Recommendation X.25 to provide the OSI-CONS) (Note 2)
0	1	0	0	1	ISO/IEC 8473 [43] (OSI connectionless mode protocol)
0	1	0	1	0	Recommendation T.70 [32] minimum network layer
0	1	0	1	1	ISO/IEC TR 9577 [82] (Protocol identification in the network layer)
1	0	0	0	0	User specified (Note 1)

All other values are reserved.

NOTE 1 – When this coding is included, octet 7a will included user coding for the user specified layer 3 protocol.

NOTE 2 – When this coding is included, octets 7a, 7b and 7c with CCITT encoding may be included.

Octet 7a for CCITT codings

Mode of operation (octet 7a)

Bits		
7	6	
0	1	Normal packet sequence numbering
1	0	Extended packet sequence numbering

All other values are reserved.

Superseded by a more recent version

TABLE 4-16/Q.931 (continued)

Low layer compatibility information element

Octet 7a for user protocol

User specified layer 3 protocol information (octet 7a)

The use and coding of octet 7a depends on user defined requirements.

Default packet size (octet 7b)

Bits	
4	3 2 1
0 1 0 0	Default packet size 16 octets
0 1 0 1	Default packet size 32 octets
0 1 1 0	Default packet size 64 octets
0 1 1 1	Default packet size 128 octets
1 0 0 0	Default packet size 256 octets
1 0 0 1	Default packet size 512 octets
1 0 1 0	Default packet size 1024 octets
1 0 1 1	Default packet size 2048 octets
1 1 0 0	Default packet size 4096 octets

All other values are reserved.

Packet window size (octet 7c)

Bits 7-1 binary coding of packet window size value in the range from 1 to 127.

Superseded by a more recent version

TABLE 4-17/Q.931

Low layer compatibility attributes

LLC attributes		Additional attributes			
Transfer mode	Information transfer capability	Structure	Configuration	Establishment	Symmetry
Circuit	Speech	8 kHz integrity	Point-to-point	Demand	Bi-directional symmetric
Circuit	Unrestricted data	8 kHz integrity	Point-to-point	Demand	Bi-directional symmetric
Circuit	Restricted data	8 kHz integrity	Point-to-point	Demand	Bi-directional symmetric
Circuit	3.1 kHz audio	8 kHz integrity	Point-to-point	Demand	Bi-directional symmetric
Circuit	Unrestricted data with tones/announcements	8 kHz integrity	Point-to-point	Demand	Bi-directional symmetric
Circuit	Video	8 kHz integrity	Point-to-point	Demand	Bi-directional symmetric
Packet	Unrestricted data	Service data unit integrity	Point-to-point	Demand	Bi-directional symmetric

NOTES

1 When the information transfer rate 2×64 kbit/s is used, 8 kHz integrity with Restricted Differential Time Delay (RDTD) is offered.

2 When multirate (64 kbit/s base rate) is indicated as the information transfer rate, Time Slot Sequence integrity shall be provided.

4.5.20 More data

The More data information element is sent by the user to the network in a USER INFORMATION message, and delivered by the network to the destination user(s) in the corresponding USER INFORMATION message. The presence of the More data information element indicates to the destination user that another USER INFORMATION message will follow, containing information belonging to the same block.

The use of the More data information element is not supervised by the network.

The More data information element is coded as shown in Figure 4-26.

The length of this information element is one octet.

Superseded by a more recent version

8	7	6	5	4	3	2	1	Octet
More data								
1	0	1	0	0	0	0	0	1
Information element identifier								

FIGURE 4-26/Q.931

More data information element

4.5.21 Network-specific facilities

The purpose of the Network-specific facilities information element is to indicate which network facilities are to be invoked. The Network-specific facilities information element is coded as shown in Figure 4-27 and Table 4-18. No more than four Network-specific facilities information elements may be included in a single message.

The maximum length of this information element is network dependent.

Bits								
8	7	6	5	4	3	2	1	Octets
Network-specific facilities								
0	0	1	0	0	0	0	0	1
Information element identifier								
Length of network-specific facilities contents								2
Length of network identification								3
1 ext.	Type of network identification			Network identification plan				3.1*
0 spare	Network identification (IA5 characters)							3.2*
Network-specific facility specification								4

NOTES

- 1 Octets 3.1 and 3.2 are only present when the length in octet 3 is non-zero.
- 2 Octet 3.2 may be repeated as appropriate.

FIGURE 4-27/Q.931

Network-specific facilities information element

Superseded by a more recent version

TABLE 4-18/Q.931

Network-specific facilities information element

Length of network identification (octet 3)

This field contains the length, in octets, of the network identification found in octet 3.1 and the repetition of octet 3.2. If the value is “0000 0000”, then the default provider (see E.1) is assumed and octets 3.1 and 3.2 are omitted.

Type of network identification (octet 3.1)

Bits	
<u>7</u>	<u>6 5</u>
0 0 0	User specified
0 1 0	National network identification (Note 1)
0 1 1	International network identification

All other values are reserved.

NOTE 1 – In the case that “type of network identification” is coded as 010, “national network identification”, “national identification plan” is coded according to national specification.

Network identification plan (octet 3.1)

Bits	
<u>4</u>	<u>3 2 1</u>
0 0 0 0	Unknown
0 0 0 1	Carrier Identification Code (Note 2)
0 0 1 1	Data network identification code (Recommendation X.121 [21])

All other values are reserved.

NOTE 2 – Carrier Identification Codes may be an appropriate method of identifying the network serving the remote user.

Network identification (octets 3.2, etc.)

These IA5 characters are organized according to the network identification plan specified in octet 3.1.

Network-specific facilities (octets 4, etc.)

This field is encoded according to the rules specified by the identified network.

4.5.22 Notification indicator

The purpose of the Notification indicator information element is to indicate information pertaining to a call.

The Notification indicator information element is coded as shown in Figure 4-28 and Table 4-19.

The maximum length of this information element is three octets.

Superseded by a more recent version

Bits								Octets
8	7	6	5	4	3	2	1	
Notification indicator								1
0	0	1	0	0	1	1	1	
Information element identifier								
Length of notification indicator contents								2
1 ext.	Notification description							3

FIGURE 4-28/Q.931

Notification indicator information element

TABLE 4-19/Q.931

Notification indicator information element

<i>Notification description (octet 3)</i>		
Bits		
7	6	5 4 3 2 1
0	0	0 0 0 0 0 0 User suspended
0	0	0 0 0 0 0 1 User resumed
0	0	0 0 0 0 1 0 Bearer service change
All other values are reserved.		

Superseded by a more recent version

4.5.23 Progress indicator

The purpose of the Progress indicator information element is to describe an event which has occurred during the life of a call. The information element may occur two times in a message.

The Progress indicator information element is coded as shown in Figure 4-29 and Table 4-20.

The maximum length of this information element is four octets.

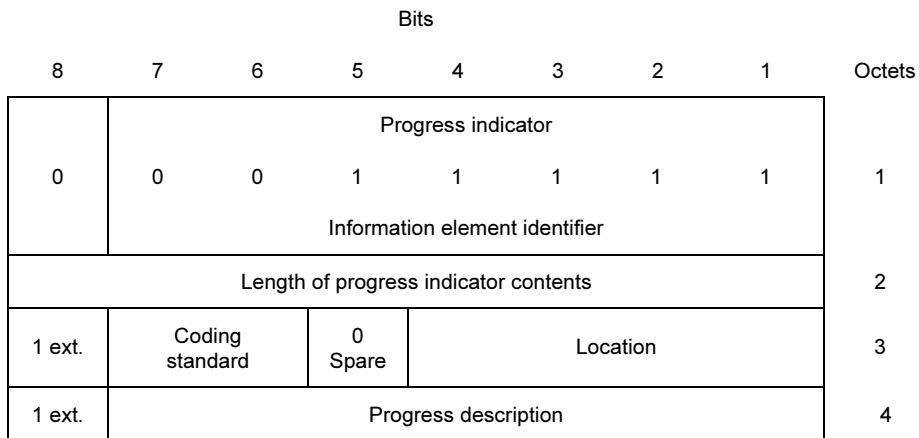

FIGURE 4-29/Q.931

Progress indicator information element

Superseded by a more recent version

TABLE 4-20/Q.931

Progress indicator information element

Coding standard (octet 3)

Bits	
7	6
0 0	CCITT standardized coding, as described below
0 1	ISO/IEC standard (Note 1)
1 0	National standard (Note 1)
1 1	Standard specific to identified location (Note 1)

NOTE 1 – These other coding standards should be used only when the desired progress indication can not be represented with the CCITT-standardized coding.

Location (octet 3)

Bits			
4	3	2	1
0 0 0 0	User		
0 0 0 1	Private network serving the local user		
0 0 1 0	Public network serving the local user		
0 0 1 1	Transit network (Note 2)		
0 1 0 0	Public network serving the remote user		
0 1 0 1	Private network serving the remote user		
1 0 1 0	Network beyond the interworking point		

All other values are reserved.

NOTE 2 – This value may be generated by some networks.

NOTE 3 – Depending on the location of the users, the local public network and remote public network may be the same network.

Progress description (octet 4)

Bits								No.
7	6	5	4	3	2	1		
0 0 0 0 0 0 1	1.	Call is not end-to-end ISDN; further call progress information may be available in-band						
0 0 0 0 0 1 0	2.	Destination address is non ISDN						
0 0 0 0 0 1 1	3.	Origination address is non ISDN						
0 0 0 0 1 0 0	4.	Call has returned to the ISDN						
0 0 0 0 1 0 1	5.	Interworking has occurred and has resulted in a telecommunication service change (Note 5)						
0 0 0 1 0 0 0	8.	In-band information or an appropriate pattern is now available.						

All other values are reserved.

NOTE 4 – The use of different progress descriptions is further explained in Annex G.

NOTE 5 – This progress description value shall be used only in the case of interworking in a full ISDN environment, e.g. when bearer capability selection is not supported or when resource or route of the preferred capability is not available. In case of interworking with a non-ISDN environment a progress description No. 1 shall be used. If the destination address is non-ISDN, the progress description No. 2 shall be used.

Superseded by a more recent version

4.5.24 Repeat indicator

The purpose of the Repeat indicator information element is to indicate how repeated information elements shall be interpreted, when included in a message. The Repeat indicator information element is included before the first occurrence of the information element which will be repeated in a message. The Repeat indication information element is coded as shown in Figure 4-30 and Table 4-21.

The length of this information element is one octet.

NOTE – Use of the Repeat indicator information element in conjunction with an information element that occurs only once in a message shall not of itself constitute an error.

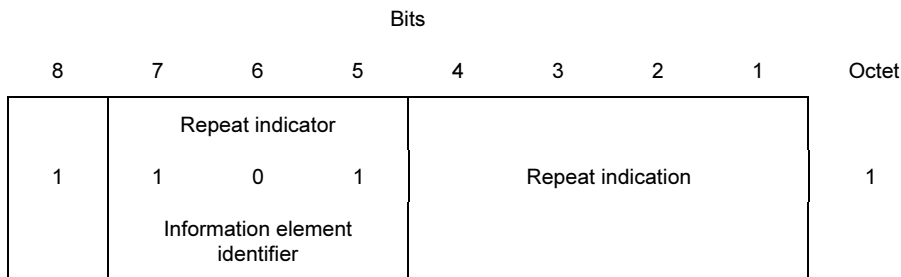

FIGURE 4-30/Q.931

Repeat indicator information element

TABLE 4-21/Q.931

Repeat indicator information element

<i>Repeat indication (octet 1)</i>	
Bits	
4 3 2 1	
0 0 1 0	Prioritized list for selecting one possibility (Note)
All other values are reserved.	
NOTE – Used for Bearer service change procedures (see Annex L).	

4.5.25 Restart indicator

The purpose of the Restart indicator information element is to identify the class of the facility (i.e. channel or interface) to be restarted.

The Restart indicator information element is coded as shown in Figure 4-31 and Table 4-22.

The maximum length of this information element is three octets.

Superseded by a more recent version

Bits								Octets
8	7	6	5	4	3	2	1	
Restart indicator								1
0	1	1	1	1	0	0	1	
Information element identifier								2
Length of restart indicator contents								
1 ext.	0	0	0	0	Class			3

FIGURE 4-31/Q.931

Restart indicator information element

TABLE 4-22/Q.931

Restart indicator information element

<i>Class (octet 3)</i>	
Bits	
<u>3</u> <u>2</u> <u>1</u>	
0 0 0	Indicated channels (Note 1)
1 1 0	Single interface (Note 2)
1 1 1	All interfaces (Note 3)
All other values are reserved.	
NOTES	
1 The channel identification information element must be included and indicates which channels are to be restarted.	
2 If non-associated signalling is used, the channel identification information element must be included to indicate the interface to be restarted if it is other than the one on which the D-channel is present.	
3 May be used when there are two or more interfaces controlled by the D-channel. The channel identification information element must not be included with this coding.	

4.5.26 Segmented message

The purpose of the Segmented message information element is to indicate that the transmission in which it appears is part of a segmented message, in addition to the use of message type SEGMENT. When included in a message segment, it appears directly after the Message type information element (see Annex H).

The Segmented message information element is coded as shown in Figure 4-32 and Table 4-23.

The length of this information element is four octets.

Superseded by a more recent version

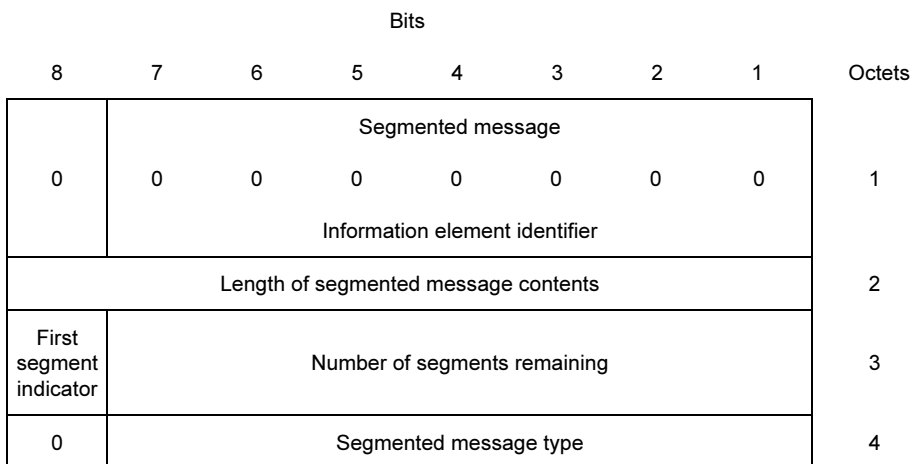

FIGURE 4-32/Q.931

Segmented message information element

TABLE 4-23/Q.931

Segmented message information element

<i>First segment indicator (octet 3)</i>	
Bit	
8	
0	Subsequent segment to first segment
1	First segment of segmented message
<i>Number of segments remaining (octet 3)</i>	
Binary number indicating the number of remaining segments within the message to be sent.	
<i>Segmented message type (octet 4)</i>	
Type of message being segmented coded as per 4.4.	
NOTE – Bit 8 is reserved for possible future use as an extension bit.	

Superseded by a more recent version

4.5.27 Sending complete

The purpose of the Sending complete information element is to optionally indicate completion of called party number, see 5.1.3, 5.2.1 and 5.2.4.

It is a single octet information element coded as shown in Figure 4-33.

Bits								Octet
8	7	6	5	4	3	2	1	
Sending complete								1
1	0	1	0	0	0	0	1	
Information element identifier								

FIGURE 4-33/Q.931

Sending complete information element

4.5.28 Signal

The purpose of the Signal information element is to allow the network to optionally convey information to a user regarding tones and alerting signals. (See 7).

The Signal information element is coded as shown in Figure 4-34 and Table 4-24.

The length of this information element is three octets.

The Signal information element may be repeated in a message.

Bits								Octets
8	7	6	5	4	3	2	1	
Signal								1
0	0	1	1	0	1	0	0	
Information element identifier								
Length of signal contents								2
0	0	0	0	0	0	0	1	
Signal value								3

FIGURE 4-34/Q.931

Signal information element

Superseded by a more recent version

TABLE 4-24/Q.931

Signal information element

<i>Signal value (octet 3)</i>								
Bits								
8	7	6	5	4	3	2	1	
0	0	0	0	0	0	0	0	Dial tone on
0	0	0	0	0	0	0	1	Ring back tone on
0	0	0	0	0	0	1	0	Intercept tone on
0	0	0	0	0	0	1	1	Network congestion tone on
0	0	0	0	0	1	0	0	Busy tone on
0	0	0	0	0	1	0	1	Confirm tone on
0	0	0	0	0	1	1	0	Answer tone on
0	0	0	0	0	1	1	1	Call waiting tone
0	0	0	0	1	0	0	0	Off-hook warning tone
0	0	0	0	1	0	0	1	Preemption tone on
0	0	1	1	1	1	1	1	Tones off
0	1	0	0	0	0	0	0	Alerting on – pattern 0 (Note 1)
0	1	0	0	0	0	0	1	Alerting on – pattern 1 (Note 1)
0	1	0	0	0	0	1	0	Alerting on – pattern 2 (Note 2)
0	1	0	0	0	0	1	1	Alerting on – pattern 3 (Note 1)
0	1	0	0	0	1	0	0	Alerting on – pattern 4 (Note 1)
0	1	0	0	0	1	0	1	Alerting on – pattern 5 (Note 1)
0	1	0	0	0	1	1	0	Alerting on – pattern 6 (Note 1)
0	1	0	0	0	1	1	1	Alerting on – pattern 7 (Note 1)
0	1	0	0	1	1	1	1	Alerting off

All other values are reserved.

NOTES

- 1 The use of these patterns is network dependent.
- 2 Used for special/priority alerting.

4.5.29 Transit network selection

The purpose of the Transit network selection information element is to identify one requested transit network. The Transit network selection information element may be repeated in a message to select a sequence of transit networks through which a call must pass (see Annex C).

The Transit network selection information element is coded as shown in Figure 4-35 and Table 4-25. The maximum length of this information element is network dependent.

Superseded by a more recent version

Bits								Octets
8	7	6	5	4	3	2	1	
0	Transit network selection							1
	1	1	1	1	0	0	0	
Information element identifier								
Length of transit network selection contents								2
1 ext.	Type of network identification			Network identification plan				3
0	Network identification (IA5 characters)							4 etc.

FIGURE 4-35/Q.931

Transit network selection information element

TABLE 4-25/Q.931

Transit network selection information element

<i>Type of network identification (octet 3)</i>	
Bits	
<u>7 6 5</u>	
0 0 0	User specified
0 1 0	National network identification (Note 1)
0 1 1	International network identification
All other values are reserved.	
NOTE 1 – In the case that “type of network identification” is coded as 010, “national network identification”, “national identification plan” is coded according to national specification.	
<i>Network identification plan (octet 3)</i>	
Bits	
<u>4 3 2 1</u>	
0 0 0 0	Unknown
0 0 0 1	Carrier Identification Code (Note 2)
0 0 1 1	Data network identification code (Recommendation X.121) [21]
All other values are reserved.	
NOTE 2 – Carrier Identification Codes may be an appropriate method of identifying the network serving the remote user.	
<i>Network identification (octet 4)</i>	
These IA5 characters are organized according to the network identification plan specified in octet 3.	

Superseded by a more recent version

4.5.30 User-user

The purpose of the User-user information element is to convey information between ISDN users. This information is not interpreted by the network, but rather is carried transparently and delivered to the remote user(s).

The User-user information element is coded as shown in Figure 4-36 and Table 4-26. There are no restrictions on content of the user information field.

In SETUP, ALERTING, CONNECT, DISCONNECT, RELEASE and RELEASE COMPLETE messages, the User-user information element has a network dependent maximum size of 35 or 131 octets. The evolution to a single maximum value is the long term objective; the exact maximum value is the subject of further study.

In USER INFORMATION messages sent in association with a circuit-mode connection, the User-user information element has a network dependent maximum size of 35 or 131 octets. For USER INFORMATION messages sent in a temporary or permanent user-user signalling connection, the user information field contained inside this information element has a maximum size equal to the maximum size of messages defined in clause 3, that is 260 octets.

NOTE – The User-user information element is transported transparently by an ISDN between a call originating entity, e.g. a calling user and the addressed entity, e.g. a remote user or a high layer function network node addressed by the call originating entity.

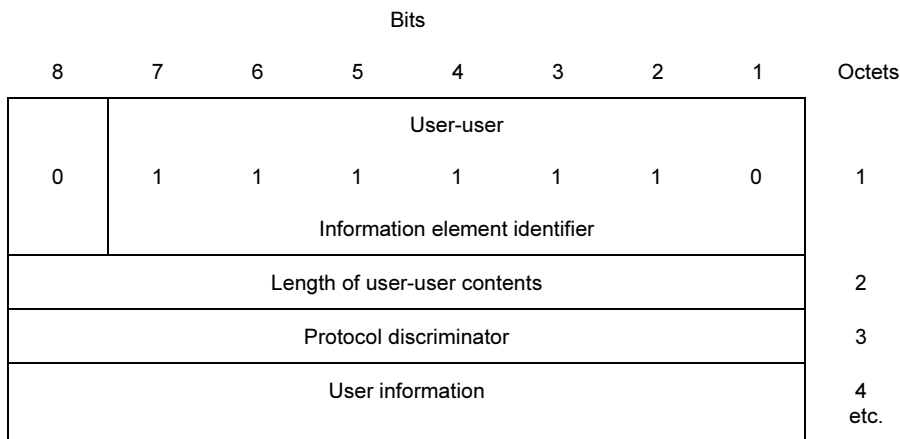

FIGURE 4-36/Q.931

User-user information element

Superseded by a more recent version

TABLE 4-26/Q.931

User-user information element

<i>Protocol discriminator (octet 3)</i>									
Bits									
	8	7	6	5	4	3	2	1	
	0	0	0	0	0	0	0	0	User-specific protocol (Note 1)
	0	0	0	0	0	0	0	1	OSI high layer protocols
	0	0	0	0	0	0	1	0	X.244 [44] (Note 2)
	0	0	0	0	0	0	1	1	Reserved for system management convergence function
	0	0	0	0	0	1	0	0	IA5 characters (Note 4)
	0	0	0	0	0	1	0	1	X.208 and X.209 coded user information (Note 5)
	0	0	0	0	0	1	1	1	Rec. V.120 [9] rate adaption
	0	0	0	0	1	0	0	0	Q.931/I.451 user-network call control messages
through	0	0	0	1	0	0	0	0	Reserved for other network layer or layer 3 protocols, Including Recommendation X.25 [5] (Note 3)
	0	0	1	1	1	1	1	1	
through	0	1	0	0	0	0	0	0	National use.
	0	1	0	0	1	1	1	1	
through	0	1	0	1	0	0	0	0	Reserved for other network layer or layer 3 Protocols, including Recommendation X.25 (Note 3)
	1	1	1	1	1	1	0		
All other values are reserved.									
NOTES									
1	The user information is structured according to user needs.								
2	The user information is structured according to Recommendation X.244 which specifies the structure of X.25 call user data.								
3	These values are reserved to discriminate these protocol discriminators from the first octet of a Recommendation X.25 packet including general format identifier.								
4	The user information consists of IA5 characters.								
5	The number of X.208 and X.209 components contained in a User-user information element as well as their semantics and use are user-application dependent and may be subject to other Recommendations.								

Superseded by a more recent version

4.6 Information element for packet communications

The information elements defined below are intended to be used in the support of packet communications as described in clause 6 and Recommendation X.31 [14].

The use of these information elements for out-of-band call control for packet calls is for further study.

4.6.1 Closed user group

The purpose of the Closed user group information element is to indicate the closed user group to be used for that call. It may be used for X.25 packet-mode calls when either an X.25 CUG selection facility or an X.25 CUG with Outgoing Access selection facility is received in an X.25 Incoming Call packet and X.25 and Q.931 mapping applies.

The Closed user group information element is coded as shown in Figure 4-37 and Table 4-27.

The maximum length of this information element is 7 octets.

		Bits									
		8	7	6	5	4	3	2	1		
0	Closed user group information element identifier	1	0	0	0	0	1	1	1	Octets	1
		Length of information element contents									
1 ext.	CUG indication	0	0	Spare	0	0					3
0 spare		CUG index code (IA5) characters)									4 etc.

FIGURE 4-37/Q.931

Closed user group information element

Superseded by a more recent version

TABLE 4-27/Q.931

Closed user group information element

CUG indication (octet 3)

Bits

3 2 1

0 0 1 Closed user group selection

0 1 0 Closed user group with outgoing access selection and indication

All other values are reserved.

CUG index code (octet 4)

Bits

7 6 5 4 3 2 1

0 1 1 0 0 0 0 0

0

0 1 1 0 0 0 0 1

1

0 1 1 0 0 1 0

2

0 1 1 0 0 1 1

3

0 1 1 0 1 0 0

4

0 1 1 0 1 0 1

5

0 1 1 0 1 1 0

6

0 1 1 0 1 1 1

7

0 1 1 1 0 0 0

8

0 1 1 1 0 0 1

9

All other values are reserved.

NOTE – The CUG index code should be represented by up to four IA5 characters, encoded as shown above.

4.6.2 End-to-end transit delay

The purpose of the End-to-end transit delay information element is to request and indicate the nominal maximum permissible transit delay applicable on a per call basis to that virtual call.

The End-to-end transit delay information element is coded as shown in Figure 4-38 and Table 4-28.

The maximum length of this information element is 11 octets.

Superseded by a more recent version

Bits								Octets
8	7	6	5	4	3	2	1	
0	End-to-end transit delay 1 0 0 0 0 0 1 0							1
Information element identifier								
Length of end-to-end transit delay contents								2
0 ext.	0	0	0	0	0	Cumulative transit delay value		3
0 ext.	Cumulative transit delay value (cont.)							3a
1 ext.	Cumulative transit delay value (cont.)							3b
0 ext.	0	0	0	0	0	Requested end-to-end transit delay value		4* (Note 1)
0 ext.	Requested end-to-end transit delay value (cont.)							4a*
1 ext.	Requested end-to-end transit delay value (cont.)							4b*
0 ext.	0	0	0	0	0	Maximum end-to-end transit delay value		5* (Note 2)
0 ext.	Maximum transit delay value (cont.)							5a*
1 ext.	Maximum transit delay value (cont.)							5b*

NOTES

- 1 Octets 4, 4a and 4b are optional. If present, these octets are always interpreted as Requested end-to-end transit delay.
- 2 Octets 5, 5a and 5b are optional. If present, octets 4, 4a and 4b must also be present.

FIGURE 4-38/Q.931

End-to-end transit delay information element

Superseded by a more recent version

TABLE 4-28/Q.931

End-to-end transit delay information element

Cumulative transit delay value [octet 3 (bits 1-2) octets 3a and 3b]

Cumulative transit delay value binary encoded in milliseconds. Bit 2 of octet 3 is the highest order bit and bit 1 of octet 3b is the lowest order bit. The cumulative transit delay value occupies 16 bits total.

Requested end-to-end transit delay value [octet 4 (bits 1-2) octets 4a and 4b]

Requested end-to-end transit delay value binary encoded in milliseconds. Bit 2 of octet 4 is the highest order bit and bit 1 of octet 4b is the lowest order bit. The requested end-to-end transit delay value occupies 16 bits total.

Maximum end-to-end transit delay value [octet 5 (bits 1-2) octets 5a and 5b]

Maximum end-to-end transit delay value binary encoded in milliseconds. Bit 2 of octet 5 is the highest order bit and bit 1 of octet 5b is the lowest order bit. The maximum end-to-end transit delay value occupies 16 bits total.

NOTE – For a Recommendation X.31 type of access to an ISDN the procedures only apply in the notification phase at the terminating exchange. At the terminating exchange, if the End-to-End Transit Delay facility is present in the X.25 [5] incoming call request packet, the contents should be copied into End-to-end transit delay information element as follows:

- i) The cumulative transit delay field (octets 3 and 4) of the X.25 end-to-end transit delay facility should be copied into octets 3, 3a and 3b. The bit order should be preserved as described above in the description.
- ii) If octets 5 and 6 are present in the Recommendation X.25 end-to-end transit delay facility, they should be interpreted as the requested end-to-end transit delay value. The value present should be copied into octets 4, 4a and 4b. The bit order should be preserved as described above in the description.
- iii) If octets 7 and 8 are present in the Recommendation X.25 end-to-end transit delay facility, the value present is the minimum end-to-end transit delay allowed. Octets 7 and 8 should be copied into octets 5, 5a and 5b. The bit order should be preserved as described above in the description.

4.6.3 Information rate

The purpose of the Information rate information element is to notify the terminating user of the throughput indicated by the incoming Recommendation X.25 call request packet.

The Information rate information element is coded as shown in Figure 4-39 and Tables 4-29 and 4-30.

The maximum length of this information element is 6 octets.

Superseded by a more recent version

Bits								Octets
8	7	6	5	4	3	2	1	
0	1	1	0	0	0	0	0	1
Information rate Information element identifier								
Length of information rate contents								2
1 ext.	0	0	Incoming information rate					3
Spare								
1 ext.	0	0	Outgoing information rate					4
Spare								
1 ext.	0	0	Minimum incoming information rate					5
Spare								
1 ext.	0	0	Minimum outgoing information rate					6
Spare								

NOTE – This information element applies only in the notification phase at the terminating exchange. If the throughput class facility/minimum throughput class facility is present in the X.25 incoming call packet the contents may be copied into the Information rate information element. The Information rate for the direction of data transmission from the calling user is copied into octet 3/5. The information rate for the direction of data transmission from the called user is copied into octet 4/6. The bit order should be preserved as described in Table 4-30.

FIGURE 4-39/Q.931

Information rate information element

TABLE 4-29/Q.931

Information rate information element

Incoming/outgoing information rate (octets 3 and 4)

The incoming outgoing information rate fields are used to indicate the information rate in the direction network to user, and user to network respectively.

The information rate for the direction of data transmission from the calling DTE is indicated in bits 5, 4, 3, 2 and 1 of octet 3. The information rate for the direction of data transmission from the called DTE is indicated in bits 5, 4, 3, 2 and 1 of octet 4. The bits are coded as specified in Table 4-30.

Minimum incoming/outgoing information rate (octets 5 and 6)

The minimum information rate for the direction of data transmission from the calling DTE is indicated in bits 5, 4, 3, 2 and 1 of octet 5. The minimum information rate for the direction of data transmission from the called DTE is indicated in bits 5, 4, 3, 2 and 1 of octet 6. The bits are encoded as specified in Table 4-30.

Superseded by a more recent version

TABLE 4-30/Q.931

Throughput class coding

5	4	Bits 3	2	1	Throughput class (bit/s)
0	0	0	0	0	Reserved
0	0	0	0	1	Reserved
0	0	0	1	0	Reserved
0	0	0	1	1	75
0	0	1	0	0	150
0	0	1	0	1	300
0	0	1	1	0	600
0	0	1	1	1	1200
0	1	0	0	0	2400
0	1	0	0	1	4800
0	1	0	1	0	9600
0	1	0	1	1	19 200
0	1	1	0	0	48 000
0	1	1	0	1	64 000
0	1	1	1	0	Reserved
0	1	1	1	1	Reserved

4.6.4 Packet layer binary parameters

The purpose of the Packet layer binary parameters information element is to indicate requested layer 3 parameter values to be used for the call.

The Packet layer binary parameters information element is coded as shown in Figure 4-40 and Table 4-31.

The maximum length of this information element is 3 octets.

Bits							Octets	
8	7	6	5	4	3	2		1
0	Packet layer binary parameters Information element identifier						1	
Length of packer layer binary parameters contents							2	
1 ext.	0	0	Fast selected		Exp data	Delivery conf.	Modulus	3
		Spare						

FIGURE 4-40/Q.931

Packet layer binary parameters information element

Superseded by a more recent version

TABLE 4-31/Q.931

Packet layer binary parameters information element

<i>fast select (octet 3)</i>	
Bit	
<u>5</u> <u>4</u>	
0 0	Fast select not requested
0 1	
1 0	Fast select requested with no restriction of response
1 1	Fast select requested with restrictions of response
<i>Expedited data (octet 3)</i>	
Bit	
<u>3</u>	
0	No request/request denied
1	Request indicated/request accepted
<i>Delivery confirmation (octet 3)</i>	
Bit	
<u>2</u>	
0	Link-by-link confirmation
1	End-to-end confirmation
<i>Modulus (octet 3)</i>	
Bit	
<u>1</u>	
0	Modulus 8 sequencing
1	Modulus 128 sequencing

4.6.5 Packet layer window size

The purpose of the Packet layer window size information element is to indicate the requested layer 3 window size value to be used for the call. The values are binary encoded.

The Packet layer window size information element is coded as shown in Figure 4-41.

The maximum length of this information element is 4 octets.

		Bits								
		8	7	6	5	4	3	2	1	Octets
0	Packet layer window size	1	0	0	0	1	0	1		1
	Information element identifier									
Length of packer layer window size contents										2
1 ext.	Forward value									3
1 ext.	Backward value									4* (Note)

NOTE – This octet may be omitted. When omitted it indicates a request for the default value.

FIGURE 4-41/Q.931

Packet layer window size information element

Superseded by a more recent version

4.6.6 Packet size

The purpose of the Packet size information element is to indicate the requested packet size values to be used for the call. The values are encoded log 2.

The Packet size information element is coded as shown in Figure 4-42.

The maximum length of this information element is 4 octets.

Bits								Octets
8	7	6	5	4	3	2	1	
Packet size								1
0	1	0	0	0	1	1	0	
Information element identifier								
Length of packet size contents								2
1 ext.	Forward value (Note 2)							3
1 ext.	Backward value (Note 2)							4* (Note 1)

NOTES

- 1 This octet may be omitted. When omitted it indicates a request for the default value.
- 2 000 0000 is reserved.

FIGURE 4-42/Q.931

Packet size information element

Superseded by a more recent version

4.6.7 Redirecting number

The purpose of the Redirecting number information element is to identify the number from which a call diversion or transfer was invoked.

The Redirecting number information element is coded as shown in Figure 4-43 and Table 4-32.

The maximum length of this information element is network dependent.

Bits								Octets
8	7	6	5	4	3	2	1	
0	1	1	1	0	1	0	0	1
Redirecting number Information element identifier								
Length of redirecting number contents								2
0/1 ext.	Type of number				Numbering plan identification			3
0/1 ext.	Presentation indicator	0 Spare		0 Spare		0 Screening indicator		3a*
1 ext.	0	0 Spare		Reason for redirection				3b*
0 spare	Number digits (IA5 characters)							4 etc.

FIGURE 4-43/Q.931

Redirecting number information element

Superseded by a more recent version

TABLE 4-32/Q.931

Redirecting number information element

Type of number (octet 3) (Note 1)

Bits

7 6 5

0 0 0	Unknown (Note 2)
0 0 1	International number (Note 3)
0 1 0	National number (Note 3)
0 1 1	Network specific number (Note 4)
1 0 0	Subscriber number (Note 3)
1 1 0	Abbreviated number
1 1 1	Reserved for extension

All other values are reserved.

NOTE 1 – For the definition of international, national and subscriber number, see Recommendation I.330 [18].

NOTE 2 – The type of number “unknown” is used when the user or the network has no knowledge of the type of number, e.g. international number, national number, etc. In this case the number of digits field is organized according to the network dialling plan; e.g. prefix or escape digits might be present.

NOTE 3 – Prefix or escape digits shall not be included.

NOTE 4 – The type of number “network specific number” is used to indicate administration/service number specific to the serving network, e.g. used to access an operator.

Numbering plan identification (octet 3)

Numbering plan (applies for type of number = 000, 001, 010 and 100)

Bits

4 3 2 1

0 0 0 0	Unknown (Note 5)
0 0 0 1	ISDN/telephony numbering plan (Recommendation E.164 [19])
0 0 1 1	Data numbering plan (Recommendation X.121 [21])
0 1 0 0	Telex numbering plan (Recommendation F.69 [22])
1 0 0 0	National standard numbering plan
1 0 0 1	Private numbering plan
1 1 1 1	Reserved for extension

All other values are reserved.

NOTE 5 – The numbering plan “unknown” is used when the user on network has no knowledge of the numbering plan. In this case the number digits field is organized according to the network dialling plan; e.g. prefix or escape digits might be present.

Presentation indicator (octet 3a)

Bits

7 6

	Meaning
0 0	Presentation allowed
0 1	Presentation restricted
1 0	Number not available due to interworking
1 1	Reserved

NOTE 6 – The meaning and use of this field is defined in 3/Q.951 and 4/Q.951

Screening indicator (octet 3a)

Bits

2 1

0 0	User-provided, not screened
0 1	User-provided, verified and passed
1 0	User-provided, verified and failed
1 1	Network provided

NOTE 7 – If octet 3a is omitted, “00 – user-provided, not screened” is assumed.

Superseded by a more recent version

TABLE 4-32/Q.931 (concluded)

Redirecting number information element

<i>Reason for redirection (octet 3b)</i>	
Bits	
4 3 2 1	
0 0 0 0	Unknown
0 0 0 1	Call forwarding busy or called DTE busy
0 0 1 0	Call forwarding no reply
0 1 0 0	Call deflection
1 0 0 1	Called DTE out of order
1 0 1 0	Call forwarding by the called DTE
1 1 1 1	Call forwarding unconditional or systematic call redirection
All other values are reserved.	
<i>Number digits (octets 4, etc.)</i>	
This field is coded with IA5 characters, according to the formats specified in the appropriate numbering/dialling plan.	

4.6.8 Reverse charging indication

The purpose of the Reverse charging information element is to indicate that reverse charging has been requested for that call. It may be used for X.25 packet-mode calls when either an X.25 Reverse charging facility is received in an X.25 Incoming Call packet and X.25 and Q.931 mapping applies.

The Reverse charging information element is coded as shown in Figure 4-44 and Table 4-33.

The maximum length of this information element is 3 octets.

Bits								Octets
8	7	6	5	4	3	2	1	
Reverse charging indication								1
0	1	0	0	1	0	1	0	
Information element identifier								2
Length of information element contents								
1 ext.	0	0	0	0	Reverse charging indication			3
Spare								

FIGURE 4-44/Q.931

Reverse charging indication information element

Superseded by a more recent version

TABLE 4-33/Q.931

Reverse charging indication information element

<i>Reverse charging indication (octet 3)</i>	
Bits	
<u>3</u> <u>2</u> <u>1</u>	
0 0 1	Reverse charging requested
All other values are reserved	

4.6.9 Transit delay selection and indication

The purpose of the Transit delay selection and indication information element is to request the nominal maximum permissible transit delay applicable on a per call basis to that virtual call.

The Transit delay selection and indication information element is coded as shown in Figure 4-45 and Table 4-34.

The maximum length of this information element is 5 octets.

Bits							Octets	
8	7	6	5	4	3	2		1
0	1	0	0	0	0	1	1	1
Transit delay selection and indication Information element identifier								
Length of transit delay selection and indication contents								2
0 ext.	0	0	0	0	0	Transit delay selection and indication value		3
Spare								
0 ext.	Transit delay selection and indication value (cont.)							3a
1 ext.	Transit delay selection and indication value (cont.)							3b

FIGURE 4-45/Q.931

Transit delay selection and indication information element

TABLE 4-34/Q.931

Transit delay selection and indication information element

<i>Transit delay selection and indication value [octet 3 (bits 1-2), octets 3a and 3b]</i>	
Transit delay value binary encoded in milliseconds. Bit 2 of octet 3 is the highest order bit and bit 1 of octet 3b is the lowest order bit. The transit delay value occupies 16 bits total.	
NOTE – For a Recommendation X.31[14] type of access to an ISDN the procedures only apply in the notification phase at the terminating exchange. At the terminating exchange, if the Transit Delay Selection and Indication facility is present in the X.25 [5] incoming call request packet, the two octet value should be copied into octets 3, 3a and 3b with the highest order bit contained in bit 2 of octet 3 and the lowest order bit contained in bit 1 of octet 3b.	

Superseded by a more recent version

5 Circuit-switched call control procedures

This clause provides the D-channel signalling procedures in support of circuit-mode bearer capabilities other than multirate (64 kbit/s base rate).

Extensions to this basic protocol and exceptions that apply in the case of packet-mode connections or of circuit-mode multirate (64 kbit/s base rate) or supplementary services are described elsewhere in this Recommendation.

The call states referred to in this clause cover the states perceived by the network, states perceived by the user, and states which are common to both user and network. Unless specifically qualified, all states described in the following text should be understood as common (see 2.1.1 and 2.1.2 for user and network call states respectively). An overview diagram of call states is given in Figures A.2 and A.3 (see Annex A).

Detailed specification and description language (SDL) diagrams for the procedures specified in this clause are contained in Figures A.4 through A.6. When there is an ambiguity in the narrative text, the SDL diagrams in Figures A.4 through A.6 should be used to resolve the conflict. Where the text and the SDL are in disagreement, the text should be used as the prime source.

NOTE 1 – This clause describes the sequences of messages associated with the control of circuit-switched connections. Optional extensions to this basic protocol and exceptions that apply in the case of packet-mode connections or supplementary services are described elsewhere in this Recommendation, in Recommendation Q.932 [4] or the Q.95x-Series Recommendations [83]. Annex D also contains extensions to the basic call establishment procedures defined in clause 5 for symmetric signalling.

All messages in this Recommendation may contain two types of information elements, functional and/or stimulus. Functional information elements are characterized as requiring a degree of intelligent processing by the terminal in either their generation or analysis. Stimulus information elements, on the other hand, are either generated as a result of a single event at the user/terminal interface or contain a basic instruction from the network to be executed by the terminal.

As a general principle, all the messages sent by the network to the user may contain a Display information element whose contents may be displayed by the terminal; the content of this information element shall be network dependent.

NOTE 2 – Keypad facility information elements shall be conveyed only in the direction user to network. Display information elements shall be conveyed only in the direction network to user.

In addition to the messages exchanged as described in the following subclauses, INFORMATION messages for call control may be sent by the user or by the network only after the first response to a SETUP message has been sent or received, and before the clearing of the call reference is initiated. An INFORMATION message received in the Release Request state may be ignored.

In order to accommodate the transfer of Layer 3 messages which exceeds the data link layer maximum frame length (i.e. defined in Recommendation Q.921 [3]), a method of message segmentation and reassembly may optionally be implemented as described in Annex H. Message segmentation shall only be used where all the information comprising the unsegmented message is available at the time of sending the first message segment.

NOTE 3 – Message segmentation is not used to replace existing procedures where information is yet to be provided by call control, e.g. digit by digit sending in overlap mode, although this may be used in addition. Message segmentation shall only be used when the message length exceeds the value of the N201 parameter defined in Recommendation Q.921 [3].

5.1 Call establishment at the originating interface

Before these procedures are invoked, a reliable data link connection must be established between the user (TE/NT2) and the network. All layer 3 messages shall be sent to the data link layer using a DL-DATA request primitive. The data link services described in Recommendations Q.920/I.440 [45] and Q.921 [3] are assumed.

5.1.1 Call request

A user initiates call establishment by transferring a SETUP message across the user-network interface. Following the transmission of the SETUP message, the call shall be considered by the user to be in the call initiated state. The message shall always contain a call reference, selected according to the procedures given in 4.3. In selecting a call reference, the dummy call reference value shall not be used in association with the basic call. The bearer capability information element is mandatory in the SETUP message, even in the case of overlap sending.

Superseded by a more recent version

If the user knows all appropriate channels controlled by the D-channel are in use, it shall not transfer a SETUP message across the user-network interface. If the user does not monitor the status of channels in use, it may send a SETUP during an all channels busy condition. In this case the network returns a RELEASE COMPLETE message with cause No. 34, *no circuit/channel available*.

Furthermore the SETUP message may also contain all or part of the call information (i.e. address and facility requests) necessary for call establishment depending on whether *en-bloc* or overlap procedures are being used respectively (see 5.1.3).

If *en-bloc* sending is used, the SETUP message shall contain all the information required by the network to process the call, and, in particular, the called party address information if present, is contained as follows:

- a) in the called party number information element possibly completed by the called party subaddress information element; or
- b) the keypad facility information element which may also be used to convey other call information.

NOTE – The support of a) is mandatory in all networks. Whether the support of b) is mandatory or optional requires further study.

If *en-bloc* sending is used, the SETUP message may contain the sending complete indication (i.e. either the Sending complete information element or the “#” character within the Called party number information element). It is mandatory for the network to recognize at least one of the sending complete indications. It is for further study which sending complete indication is preferred.

For overlap sending, see 5.1.3.

Called party subaddress information, if present, shall be given in the Called party subaddress information element and, in the case of overlap sending, shall be sent only in the SETUP message.

5.1.2 B-channel selection – Originating

In the SETUP message, the user will indicate one of the following:

- a) channel is indicated, no acceptable alternative [i.e. channel is indicated by the information channel selection field of octet 3 (bits 2-1) and, if applicable, octet 3.3, and the preferred/exclusive field (bit 4 of octet 3) is set to “1” in the Channel identification information element]; or
- b) channel is indicated, any alternative is acceptable [i.e. channel is indicated by the information channel selection field of octet 3 (bits 2-1) and, if applicable, octet 3.3, and the preferred/exclusive field (bit 4 of octet 3) is set to “0” in the Channel identification information element]; or
- c) any channel is acceptable [i.e. either the information channel selection field of octet 3 (bits 2-1) of the Channel identification information element indicate “any channel” or the Channel identification information element is not present].

If no indication is included, alternative c) is assumed. In cases a) and b), if the indicated channel is available, the network selects it for the call.

In case b), if the network cannot grant the preferred channel, it selects any other available B-channel associated with the D-channel. In case c), the network selects any available B-channel associated with the D-channel.

NOTE – It is recommended that TEs connected to the ISDN basic access in a point-to-multipoint configuration use alternative c) for basic circuit-switched call control unless the TE is already using a given B-channel.

The selected B-channel is indicated in the Channel identification information element coded as “channel is indicated, no acceptable alternative” in the first message returned by the network in response to the SETUP message (i.e. a SETUP ACKNOWLEDGE or CALL PROCEEDING message). After transmitting this message, the network shall activate the B-channel connection.

The user need not attach until receiving a CALL PROCEEDING/SETUP ACKNOWLEDGE/PROGRESS/ALERTING message with the progress indicator No. 8, *in-band information or appropriate pattern is now available* or progress indication No. 1, *call is not end-to-end ISDN; further call progress information may be available in-band*. Prior to this

Superseded by a more recent version

time, the network cannot assume that the user has attached to the B-channel. After this time, the user shall be connected to the B-channel, provided the equipment does not generate local tone. Upon receipt of the CONNECT message the user shall attach to the B-channel (if it has not already done so).

In case a) if the specified channel is not available, and in cases b) and c) if no channel is available, a RELEASE COMPLETE message with cause No. 44, *requested circuit/channel not available* or No. 34, *no circuit/channel available*, respectively, is sent by the network as described in 5.3.

In case a), if the specified channel does not exist, cause No. 82, *identified channel does not exist* is included in the RELEASE COMPLETE message.

5.1.3 Overlap sending

If overlap sending is used, the SETUP message contains either:

- a) no called number information; or
- b) incomplete called number information; or
- c) called number information which the network cannot determine to be complete.

On receipt of such a SETUP message, the network starts timer T302 (the value of timer T302 is specified in 9.1), sends a SETUP ACKNOWLEDGE message to the user, and enters the overlap sending state. In case a), the network will return dial tone, if required by the tone option. In this case it may include progress indicator No. 8, *in-band information or appropriate pattern is now available* in the SETUP ACKNOWLEDGE message.

NOTE 1 – Some networks which systematically provide the conventional telephone dial tone will not generate the progress indicator when providing the dial tone.

When the SETUP ACKNOWLEDGE message is received, the user enters the overlap sending state and optionally starts timer T304 (the value of timer T304 is specified in 9.2).

After receiving the SETUP ACKNOWLEDGE message, the user sends the remainder of the call information (if any) in one or more INFORMATION messages.

The called party number information may be provided by the user as follows:

- a) in the called party number information element; or
- b) in the keypad facility information element, exclusively.

The called party number must be sent in a unique way.

NOTE 2 – The support of a) is mandatory in all networks. Whether the support of b) is mandatory or optional requires further study.

NOTE 3 – Besides the possible called party number [conveyed by method a) or b) as described above], the INFORMATION messages may contain additional call information (i.e. for supplementary services). The interpretation of the contents of keypad facility information elements is network-specific, and in accordance with the dialling plan provided to that user. It should be noted that the user shall transfer all the additional call information (contained within the keypad facility information element) before the network determines that the called party number (contained within the called party number information element or the keypad facility information element) is complete, and terminates the overlap sending procedure using the CALL PROCEEDING message as recommended in 5.1.5.2.

If, for symmetry purposes, the user employs timer T304, the user restarts timer T304 when each INFORMATION message is sent.

The call information in the message which completes the information sending may contain a *sending complete* indication, (e.g. the # character or, as a network option, the sending complete information element) appropriate to the dialling plan being used. The network shall restart timer T302 on the receipt of every INFORMATION message not containing a sending complete indication.

5.1.4 Invalid call information

If, following the receipt of a SETUP message or during overlap sending, the network determines that the call information received from the user is invalid, (e.g. invalid number), then the network shall follow the procedures described in 5.3 with a cause such as one of the following:

- No. 1 – *Unassigned (unallocated) number*;
- No. 3 – *No route to destination*;
- No. 22 – *Number changed*;
- No. 28 – *Invalid number format (incomplete number)*.

Superseded by a more recent version

5.1.5 Call proceeding

5.1.5.1 Call proceeding, *en-bloc* sending

If *en-bloc* sending is used, (i.e. the network can determine that the SETUP message contains all the information required from the user to establish the call) and if the network can determine that access to the requested service is authorized and available, the network shall send a CALL PROCEEDING message to the user. This acknowledges the SETUP message, and indicates that the call is being processed. The network will then enter the Outgoing Call Proceeding state. When the user receives the CALL PROCEEDING message, the user shall also enter the Outgoing Call Proceeding state.

Similarly, if the network determines that a requested service is not authorized or is not available, the network shall initiate call clearing in accordance with 5.3, with one of the following causes:

No. 57 – *Bearer capability not authorized;*

No. 58 – *Bearer capability not presently available;*

No. 63 – *Service or option not available, unspecified; or*

No. 65 – *Bearer service not implemented.*

NOTES

1 If a supplementary service is not authorized or is not available, the procedure to be used is defined in the supplementary service control procedures.

2 When the network cannot assign a channel due to congestion, the procedures of 5.1.2 shall be followed.

5.1.5.2 Call proceeding, overlap sending

If overlap sending is used, then following the occurrence of one of these conditions:

- a) the receipt by the network of a sending complete indication which the network understands; or
- b) analysis by the network that all call information necessary to effect call establishment has been received,

and if the network can determine that access to the requested service and supplementary service is authorized and available, the network shall: send a CALL PROCEEDING message to the user; stop timer T302; and enter the Outgoing Call Proceeding state. Similarly if the network determines that a requested service or supplementary service is not authorized or is not available, the network shall initiate call clearing in accordance with 5.3, with one of the following causes:

No. 57 – *Bearer capability not authorized;*

No. 58 – *Bearer capability not presently available;*

No. 63 – *Service or option not available, unspecified; or*

No. 65 – *Bearer service not implemented.*

NOTES

1 The CALL PROCEEDING message is sent to indicate that the requested call establishment has been initiated, and no more call establishment information will be accepted.

2 If a supplementary service is not authorized or is not available, the procedure to be used is defined in the supplementary service control procedures.

3 When the network cannot assign a channel due to congestion, the procedures of 5.1.2 shall be followed.

When the user receives the CALL PROCEEDING message, the user shall enter the outgoing call proceeding state. If, for symmetry purposes, the calling user employs timer T304, the user shall stop timer T304 when the CALL PROCEEDING message is received. If, for symmetry purposes, the calling user employs timer T304 then, on expiry of T304, the user shall initiate call clearing in accordance with 5.3 with cause No. 102, *recovery on time expiry*.

An alerting or connect indication received from the called party will stop timer T302 and cause an ALERTING or CONNECT message respectively to be sent to the calling user. No CALL PROCEEDING message shall be sent by the network. If, for symmetry purposes, the calling user employs timer T304, the user shall stop timer T304 on receiving the ALERTING or CONNECT message.

Superseded by a more recent version

At the expiration of timer T302, the network shall

- i) initiate call clearing in accordance with 5.3, with cause No. 28, *invalid number format* (incomplete number) sent to the calling user and with cause No. 102, *recovery on timer expiry* is sent towards the called user, if the network determines that the call information is definitely incomplete; otherwise
- ii) send a CALL PROCEEDING message and enter the outgoing call proceeding state.

5.1.6 Notification of interworking at the originating interface

During call establishment, the call may leave the ISDN environment, e.g. because of interworking with another network, with a non-ISDN user, or with non-ISDN equipment within the called user's premises. When such situations occur a progress indication shall be returned to the calling user either:

- a) in an appropriate call control message when a state change is required: CALL PROCEEDING, ALERTING, SETUP ACKNOWLEDGE or CONNECT; or
- b) in the PROGRESS message when no state change is appropriate.

One of the following progress description values shall be included in the Progress indicator information element in the messages sent to the user, (for further information see Annex G).

- 1) No. 1 – *Call is not end-to-end ISDN; further call progress information may be available in-band;*
- 2) No. 2 – *Destination address is non-ISDN;*
- 3) No. 4 – *Call has returned to the ISDN.*

If the Progress indicator information element is included in a call control message, the procedures as described in the rest of 5.1 apply. If the Progress indicator information element is included in the Progress message, no state change will occur but any supervisory timers shall be stopped except network timer T302. In both cases, if indicated by the Progress indicator information element, the user shall connect to (if not connected already) and then monitor the B channel for further in-band information.

If the interface at which the progress indication originates is the point at which a call enters the ISDN environment from a non-ISDN environment, one or more of the following progress indicator information elements shall be included in the SETUP message sent to the network:

- i) No. 1 – *Call is not end-to-end ISDN; further call progress information may be available in-band;*
- ii) No. 3 – *Origination address is non-ISDN.*

5.1.7 Call confirmation indication

Upon receiving an indication that user alerting has been initiated at the called address, the network shall send an ALERTING message across the user-network interface of the calling address, and shall enter the call delivered state. When the user receives the ALERTING message, the user may begin an internally-generated alerting indication and shall enter the call delivered state.

5.1.8 Call connected

Upon the network receiving an indication that the call has been accepted, the network shall send a CONNECT message across the user-network interface to the calling user, and shall enter the Active state. As a network option, the Date/time information element may be included in the CONNECT message.

This message indicates to the calling user that a connection has been established through the network and stops a possible local indication of alerting.

On receipt of the CONNECT message, the calling user shall stop any user-generated alerting indications; may optionally send a CONNECT ACKNOWLEDGE message, and shall enter the active state. The network shall not take any action on receipt of a CONNECT ACKNOWLEDGE message when it perceives the call to be in the active state.

Superseded by a more recent version

5.1.9 Call rejection

Upon receiving an indication that the network or the called user is unable to accept the call, the network shall initiate call clearing at the originating user-network interface as described in 5.3, using the cause provided by the terminating network or the called user.

5.1.10 Transit network selection

When the transit network selection information element is present, the call shall be processed according to Annex C.

5.2 Call establishment at the destination interface

This procedure assumes that a data link connection providing services described in Recommendation Q.920/I.440 [45] may not exist before the first layer 3 message (SETUP) is transferred across the interface. However, reliable data link connections must be established by each of the users (terminals and/or NT2s) at the interface before they respond to the SETUP message.

Data link connections may be established by the TA, TE or NT2 as soon as a TEI is assigned (either locally or by automatic assignment procedure), and may be retained indefinitely. This may be recommended as a network option.

The SETUP message offered on a point-to-point data link shall be delivered to layer 2 using a DL-DATA request primitive. No use shall be made of the DL-UNIT-DATA request primitive other than for operation using the broadcast capability of the data link layer.

The call reference contained in all messages exchanged across the user-network interface shall contain the call reference value specified in the SETUP message delivered by the network. In selecting a call reference, the dummy call reference shall not be used in association with the basic call.

5.2.1 Incoming call

The network will indicate the arrival of a call at the user-network interface by transferring a SETUP message across the interface. This message is sent if the network can select an idle B-channel. In some circumstances (e.g. provision of other bearer services see 6.1) the SETUP message may also be sent when no B-channel is idle. The number of calls presented in these circumstances may be limited.

In addition to the mandatory information elements, the SETUP message may include, as required, the information elements described in 3.1.14 (e.g. Display, Low layer compatibility).

If a multipoint terminal configuration exists at the user-network interface, this message shall be sent using a broadcast capability at the data link layer. In this case, the SETUP message should contain the appropriate part of the called party number as required and/or sub-address if provided. However, if the network has knowledge that a single-point configuration exists at the interface, a point-to-point data link shall be used to carry the SETUP message. The knowledge that a point-to-point configuration exists may be based on information entered at the time of configuration of the access. After sending the SETUP message, the network starts timer T303. If the SETUP message is sent via a broadcast data link, timer T312 shall also be started. (The values of timers T303 and T312 are specified in 9.1.) The network then enters the call present state.

NOTE 1 – Timer T312 is used to supervise the retention of the call reference when the SETUP message was transmitted by a broadcast data link. The value of timer T312 is such that if a network disconnect indication is received during the call establishment phase, it maximizes the probability that all responding users will be released prior to release of the call reference. Refer to 5.3.2 e) and 5.2.5.3 (Case 1) for procedures to be followed on expiry of timer T312.

If *en-bloc* receiving is used, the SETUP message shall contain all the information required by the called user to process the call. In this case, the SETUP message may contain the Sending complete information element.

Upon receipt of a SETUP message, the user will enter the Call present state.

Depending on the contents of the received message, either *en-bloc* receiving procedure (see 5.2.5.1) or overlap receiving procedure (see 5.2.4) follows. However, if the SETUP message includes the Sending complete information element, *en-bloc* receiving procedure shall follow. Therefore, those users who support overlap receiving procedure shall recognize the Sending complete information element.

Superseded by a more recent version

NOTE 2 – Users supporting only the *en-bloc* receiving procedure need not recognize the Sending complete information element and may directly analyze the received SETUP message on the assumption that all the call information is contained in the message.

If no response to the SETUP message is received by the network before the first expiry of timer T303, the SETUP message will be retransmitted and timers T303 and T312 restarted.

NOTE 3 – In the case of overlap sending within the network, the appropriate part of the called party number as required (e.g. for supplementary services) may also be conveyed by means of INFORMATION messages to the called user on a point-to-point data link (see 5.2.4).

5.2.2 Compatibility checking

A user receiving a SETUP message shall perform compatibility checking before responding to that SETUP message. Any reference to user in 5.2.3 through 5.2.7 implicitly refers to a compatible user equipment. Annex B defines compatibility checking to be performed by users upon receiving a SETUP message.

When the SETUP message is delivered via a broadcast data link, an incompatible user shall either:

- a) ignore the incoming call; or
- b) respond by sending a RELEASE COMPLETE message with cause No. 88, *incompatible destination*, and enter the Null state. The network processes this RELEASE COMPLETE message in accordance with 5.2.5.3.

When the SETUP message is delivered via a point-to-point data link, an incompatible user shall respond with RELEASE COMPLETE message with cause No. 88, *incompatible destination*, and enter the Null state. The network shall process this RELEASE COMPLETE message in accordance with 5.2.5.3.

5.2.3 B-channel selection – Destination

5.2.3.1 SETUP message delivered by point-to-point data link

When the SETUP message is delivered by a point-to-point data link, negotiation for the selection of a B-channel will be permitted between the network and the user. Only B-channels controlled by the same D-channel will be the subject of the selection procedure. The selection procedure is as follows:

- a) In the SETUP message, the network will indicate one of the following:
 - 1) channel is indicated, no acceptable alternative [i.e. channel is indicated by the information channel selection field of octet 3 (bits 2-1) and, if applicable, octet 3.3, and the preferred/exclusive field (bit 4 of octet 3) is set to “1” in the Channel identification information element]; or
 - 2) channel is indicated, any alternative is acceptable [i.e. channel is indicated by the information channel selection field of octet 3 (bits 2-1) and, if applicable, octet 3.3, and the preferred/exclusive field (bit 4 of octet 3) is set to “0” in the Channel identification information element]; or
 - 3) any channel is acceptable [i.e. either the information channel selection field of octet 3 (bits 2-1) of the Channel identification information element indicate “any channel” or the Channel identification information element is not present]; or
 - 4) no B-channel available [i.e. the information channel field (Bits 2 and 1 of octet 3) of the Channel identification information element set to “00”].

NOTE – Not all networks will support the *no B-channel available* condition.

- b) In cases 1) and 2), if the indicated channel is acceptable and available, the user selects it for the call.

In case 2), if the user cannot grant the indicated channel, it selects any other available B-channel associated with the D-channel, and identifies that channel in the Channel identification information element as “channel is indicated, no acceptable alternative” in the first message sent in response to the SETUP message.

In case 3), the user selects any available B-channel associated with the D-channel, and identifies that channel in the first message sent in response to the SETUP message.

If in case 1) the B-channel indicated in the first response message is not the channel offered by the network, or in cases 2) and 3) the B-channel indicated in the first response message is unacceptable to the network, it will clear the call by sending a RELEASE message with cause No. 6, *channel unacceptable*.

Superseded by a more recent version

In case 4), the user rejects the call by sending RELEASE COMPLETE message with cause No. 34 *no circuit/channel available* unless it is able to proceed with the call. Unless the procedures of the Call Waiting supplementary service (see Recommendation Q.953 [84]) are followed, the user wishing to re-use a B-channel it has already allocated to another call (e.g. by multiplexing packet calls) shall send the appropriate message containing the channel identification information element, coded as *channel is indicated, no alternative acceptable*.

- c) If no Channel identification information element is present in the first response message, the B-channel indicated in the SETUP message will be assumed.
- d) When a B-channel has been selected by the user, that channel may be connected by the user.
- e) In case 1) if the indicated B-channel is not available, or in cases 2), 3), and 4) if no B-channel is available and the user cannot proceed with the offered call, the user returns a RELEASE COMPLETE message with cause No. 44 *requested circuit/channel not available* or No. 34 *no circuit/channel available*, respectively, and returns to the Null state.

See 5.2.4 and 5.2.5 for the appropriate first response to the SETUP message.

5.2.3.2 SETUP message delivered by broadcast data link

When the SETUP message is delivered by a broadcast data link the channel selection procedure, provided in 5.2.3.1, is not applicable. The network sends a SETUP message with the Channel identification information element indicating one of the following:

- a) channel indicated, no alternative is acceptable [i.e. channel is indicated by the information channel selection field of octet 3 (bits 2-1) and, if applicable, octet 3.3, and the preferred/exclusive field (bit 4 of octet 3) is set to "1" in the Channel identification information element]; or
- b) no channel available [i.e. the information channel field (bits 2 and 1 of octet 3) of the Channel identification information element set to "00"].

The network starts timers T303 and T312.

In case a), if the user can accept the call on the indicated channel, the user shall send the appropriate message (see 5.2.4 and 5.2.5). If the user cannot accept the call on the indicated channel, the user shall send a RELEASE COMPLETE message with cause No. 44, *requested circuit/channel not available*.

The user, in any case, must not connect to the channel until a CONNECT ACKNOWLEDGE message has been received.

In case b), the user not controlling any channel shall send a RELEASE COMPLETE message with cause No. 34, *no circuit/channel available*. Unless the procedures of the Call Waiting supplementary service (see Recommendation Q.953 [84]) are followed, the user wishing to re-use a B-channel it has already allocated to another call (e.g. by multiplexing packet calls) shall send the appropriate message containing the Channel identification information element, coded as *channel is indicated, no alternative acceptable*.

5.2.4 Overlap receiving

When a user determines that a received SETUP message contains either:

- a) no called number information; or
- b) incomplete called number information; or
- c) called number information which the user cannot determine to be complete; and

when the user

- d) is compatible with other call characteristics (see Annex B); and
- e) implements overlap receiving;

the user shall start timer T302; send a SETUP ACKNOWLEDGE message to the network; and enter the Overlap receiving state.

When the SETUP ACKNOWLEDGE message is received, the network shall: stop timer T303; start timer T304; enter the Overlap receiving state; and send the remainder of the call information (if any) in one or more INFORMATION messages, starting timer T304 when each INFORMATION message is sent.

Superseded by a more recent version

The called party number information is provided in the Called party number information element.

The call address information may contain a *sending complete* indication (e.g. No. or, as a network option, the Sending complete information element) appropriate to the dialling plan being used.

NOTE 1 – If the network can determine that sufficient call set-up information will be received by the called user by sending the next INFORMATION message, it is recommended that the INFORMATION message contains the Sending complete information element.

The user shall start timer T302 on receipt of every INFORMATION message not containing a sending complete indication.

Following the receipt of a sending complete indication which the user understands, or the determination that sufficient call information has been received, the user shall stop timer T302 (if implemented) and send a CALL PROCEEDING message to the network. Alternatively, depending on internal events, the user may send an ALERTING or a CONNECT message to the network.

NOTE 2 – The CALL PROCEEDING message in this case will cause the originating exchange to send a CALL PROCEEDING message to the originating user, if not already sent.

At the expiration of timer T302 the user shall

- a) initiate clearing in accordance with 5.3, with cause No. 28, *invalid number format (incomplete number)* if it determines that the call information is definitely incomplete; or
- b) if sufficient information has been received, send a CALL PROCEEDING, ALERTING or CONNECT message as appropriate.

At the expiration of timer T304 the network initiates call clearing in accordance with 5.3, with cause No. 28, *invalid number format (incomplete number)* sent to the calling user, and cause No. 102, *recovery on timer expiry* sent to the called user.

If, following the receipt of a SETUP message or during overlap receiving, the user determines that the received call information is invalid (e.g. invalid called party number), it shall initiate call clearing in accordance with 5.3 with a cause such as one of the following:

- No. 1 – *Unassigned (unallocated) number*;
- No. 3 – *No route to destination*;
- No. 22 – *Number changed*;
- No. 28 – *Invalid number format (incomplete number)*.

Upon receipt of the complete call information the user may further perform some compatibility checking functions, as outlined in Annex B.

When the call is offered on a point-to-point data link, only one SETUP ACKNOWLEDGE message can be received in response to the call offering.

When the call is offered to the user on a broadcast data link, multiple SETUP ACKNOWLEDGE messages may be received by the network which shall then complete as many overlap receiving procedures as such SETUP ACKNOWLEDGE messages were received. It is the network responsibility to limit the number of overlap receiving procedures to be completed for a given call. The default maximum is fixed to eight. Some networks will limit the call offering completion in overlap receiving to single data link and will therefore clear the subsequent responding users after the first SETUP ACKNOWLEDGE message has been received, in accordance with the non-selected user clearing procedures described in 5.2.9.

5.2.5 Call confirmation

5.2.5.1 Response to *en-block* SETUP or completion of overlap receiving

When the user determines that sufficient call set-up information has been received and compatibility requirements (see Annex B) have been satisfied, the user responds with either a CALL PROCEEDING, ALERTING, or CONNECT message (see Note), and enters the Incoming Call Proceeding, Call Received, or Connect Request state respectively.

NOTE – A Progress indicator information element may be included in CALL PROCEEDING, ALERTING and CONNECT messages (e.g. when an analogue terminal is connected to an ISDN PABX). The CALL PROCEEDING message may be sent by the user which cannot respond to a SETUP message with an ALERTING, CONNECT, or RELEASE COMPLETE message before expiration of timer T303.

Superseded by a more recent version

When the SETUP message was delivered via a broadcast data link, an incompatible user shall either

- a) ignore the incoming call; or
- b) respond by sending a RELEASE COMPLETE message with cause No. 88, *incompatible destination*, and enter the Null state. The network processes this RELEASE COMPLETE message in accordance with 5.2.5.3.

When the SETUP message was delivered via a point-to-point data link, an incompatible user shall respond with a RELEASE COMPLETE message with cause No. 88, *incompatible destination*. The network processes this RELEASE COMPLETE message in accordance with 5.2.5.3.

A busy user which satisfies the compatibility requirements indicated in the SETUP message shall normally respond with a RELEASE COMPLETE message with cause No. 17, *user busy*. The network processes this RELEASE COMPLETE message in accordance with 5.2.5.3.

If the user wishes to refuse the call, a RELEASE COMPLETE message shall be sent with the cause No. 21, *call rejected*, and the user returns to the Null state. The network processes this RELEASE COMPLETE message in accordance with 5.2.5.3.

5.2.5.2 Receipt of CALL PROCEEDING and ALERTING

When the SETUP message is delivered on a broadcast data link, the network shall maintain a state machine that tracks the overall progression of the incoming call. The network shall also maintain an associated call state for each responding user as determined by the data link on which a message is received.

Upon receipt of the first CALL PROCEEDING message from a user (assuming no other user had previously responded with an ALERTING or CONNECT message when the SETUP message has been delivered on a broadcast data link), the network shall stop timer T303 (or, in the case of overlap receiving, timer T304 for that user); start timer T310, and enter the incoming call proceeding state.

When the SETUP message has been delivered on a broadcast data link, the network shall (at a minimum) associate the incoming call proceeding state with each called user that sends a CALL PROCEEDING message as a first response to the broadcast SETUP message prior to expiration of timer T312. Actions to be taken when a user sends a first response to an incoming call after the expiration of timer T312 are described in 5.2.5.4. Timer T310 shall not be restarted.

Upon receipt of the first ALERTING message from a user (assuming no other user has previously responded with a CONNECT message when the SETUP message has been delivered on a broadcast data link), the network shall stop timer T304 for that user (in the case of overlap receiving); stop timer T303 or T310 (if running); start timer T301 (unless another internal alerting supervision timer function exists, e.g. incorporated in call control); enter the call received state, and send a corresponding ALERTING message to the calling user.

When the SETUP message has been delivered on a broadcast data link, the network shall (at a minimum) associate the call received state with each called user that sends an ALERTING message either as a first response to the broadcast SETUP message or following a CALL PROCEEDING message. Timer T304 shall not be restarted.

5.2.5.3 Called user clearing during incoming call establishment

If the SETUP message has been delivered on a point-to-point data link and a RELEASE COMPLETE or DISCONNECT message is received before a CONNECT message has been received, the network shall stop timer T303, T304, T310 or T301 (if running); continue to clear the user as described in 5.3.3, and clear the call to the calling user with the cause received in the RELEASE COMPLETE or DISCONNECT message.

If the SETUP message has been delivered on a broadcast data link and a RELEASE COMPLETE message is received whilst timer T303 is running, the message cause shall be retained by the network. If timer T303 expires (i.e. if no valid message such as CALL PROCEEDING, ALERTING or CONNECT has been received) the cause previously retained when a RELEASE COMPLETE message was received is sent back to the calling user in a DISCONNECT message and the network shall enter the Call Abort state. When multiple RELEASE COMPLETE messages are received with different causes, the network shall

- 1) ignore any cause No. 88, *incompatible destination*; and

Superseded by a more recent version

- 2) give preference to the following causes (if received) in the order listed below:
(highest) No. 17 *user busy*;
No. 21 *call rejected*;
- 3) any other received cause may also be included in the clearing message sent to the originating user (see 5.3).

If the SETUP message has been delivered on a broadcast data link and a user which has previously sent a SETUP ACKNOWLEDGE, CALL PROCEEDING or ALERTING message sends a DISCONNECT message to the network, the actions taken by the network depend on whether timer T312 is running and whether other called users have responded to the SETUP message.

Case 1 – DISCONNECT received prior to expiry of timer T312

If timer T312 is running and the network receives a DISCONNECT message after having received a SETUP ACKNOWLEDGE, CALL PROCEEDING or ALERTING message from a called user (but before receiving a CONNECT message), timer T312, as well as timer T310 or T301 (if running), should continue to run. The network shall retain the cause in the DISCONNECT message and shall continue to clear the user as described in 5.3.3. The network shall stop timer T304 (if running) for this user.

Upon expiration of timer T312, if either

- a) no other users have responded to the incoming call; or
- b) all users that have responded to the incoming call have been cleared or are in the process of being cleared,

the network shall stop timer T310 or T301 (if running) and shall clear the call to the calling user. If an ALERTING message has been received, the cause sent to the calling user shall be a cause received from the called user, giving preference to (in order of priority): No. 21, *call rejected*; any other cause sent by a called user. If only SETUP ACKNOWLEDGE, or CALL PROCEEDING messages have been received, the cause sent to the calling user shall be a cause received from the called user, giving preference to (in order of priority): No. 17, *user busy*; No. 21, *call rejected*; any other appropriate cause sent by a called user.

Case 2 – DISCONNECT received after expiry of timer T312

If timer T312 has expired and the network receives a DISCONNECT message from the called user after having received a SETUP ACKNOWLEDGE, CALL PROCEEDING or ALERTING message (but before receiving a CONNECT message), the network shall continue to clear the user as described in 5.3.3. The network shall stop timer T304 (if running) for this user.

If other called users have responded to the SETUP message with a SETUP ACKNOWLEDGE, CALL PROCEEDING or ALERTING message, and still have the opportunity to accept the call by sending a CONNECT message, the network shall retain the cause in the DISCONNECT message. The network shall continue to process the incoming call for the remaining responding users (T310 or T301, if running, shall continue to run).

If either

- a) no other users have responded to the incoming call; or
- b) all users that have responded to the incoming call have been cleared or are in the process of being cleared,

the network shall stop timer T310 or T301 (if running) and shall clear the call to the calling user. If an ALERTING message has been received, the cause sent to the calling user shall be a cause received from the called user, giving preference to (in order of priority): No. 21, *call rejected*; or any other cause sent by a called user. If only SETUP ACKNOWLEDGE, or CALL PROCEEDING message have been received, the cause sent to the calling user shall be a cause received from the called user, giving preference to (in order of priority): No. 17, *user busy*; No. 21, *call rejected*; any other appropriate cause sent by a called user.

5.2.5.4 Call failure

If the network does not receive any response to the retransmitted SETUP message prior to the expiration of timer T303, then the network shall initiate clearing procedures towards the calling user with cause No. 18, *no user responding*.

- a) If the SETUP message was delivered by a broadcast data link, the network shall enter the Call Abort state.
- b) If the SETUP message was delivered on a point-to-point data link, the network shall also initiate clearing procedures towards the called user in accordance with 5.3.4, using cause No. 102, *recovery on timer expiry*.

Superseded by a more recent version

If the network receives a user's first response to SETUP when in the Call Abort state but before timer T312 has expired, the network shall initiate clearing to the called user as described in 5.3.2 b), except that the cause No. 102, *recovery on timer expiry* shall be sent. If the network receives a message that is a user's first response to an incoming call after timer T312 has expired, the network will interpret this message as a message received with an invalid call reference value, as described in 5.8.3.2.

If the network has received a CALL PROCEEDING message, but does not receive an ALERTING, CONNECT, or DISCONNECT message prior to the expiration of timer T310, then the network shall initiate clearing procedures towards the calling user with cause No. 18, *no user responding* and initiate clearing procedures towards the called user.

- 1) If the SETUP message is delivered by a broadcast data link, the called user shall be cleared in accordance with 5.3.2 e), except that cause No. 102, *recovery on timer expiry* shall be sent.
- 2) If the SETUP message was delivered on a point-to-point data link, the called user shall be cleared in accordance with 5.3.4 using cause No. 102, *recovery on timer expiry*.

If the network has received an ALERTING message, but does not receive a CONNECT or DISCONNECT message prior to the expiry of timer T301 (or a corresponding internal alerting supervision timing function), then the network shall initiate clearing procedures towards the calling user with cause No. 19, *user alerting, no answer*; and initiate clearing procedures towards the called user.

- i) If the SETUP message was delivered by a broadcast data link, the called user shall be cleared in accordance with 5.3.2 e), except that cause No. 102, *recovery on timer expiry* shall be sent.
- ii) If the SETUP message was delivered on a point-to-point data link, the called user shall be cleared in accordance with 5.3.4, using cause No. 102, *recovery on timer expiry*.

5.2.6 Notification of interworking at the terminating interface

During call establishment the call may enter an ISDN environment, e.g. because of interworking with another network, with a non-ISDN user, or with non-ISDN equipment within the calling or called user's premises. When this occurs, the point at which the call enters an ISDN environment shall cause a Progress indicator information element to be included in the SETUP message to be sent to the called user:

- a) *No. 1 "call is not end-to-end ISDN; further call progress information may be available in-band"*;

NOTE – On receipt of progress indicator No. 1, the called user shall connect to the B-channel in accordance with the procedures of 5.2.8.

- b) *No. 3 "origination address is non-ISDN"*.

In addition, the user shall notify the calling party if the call has left the ISDN environment within the called user's premises, or upon the availability of in-band information/patterns. When such situations occur, a progress indication shall be sent by the user to the network either

- a) in an appropriate call control message when a state change is required (SETUP ACKNOWLEDGE, CALL PROCEEDING, ALERTING, or CONNECT); or
- b) in the PROGRESS message when no state change is appropriate.

One of the following progress description values shall be included in the Progress indicator information element in the message sent to the network (for further information, see Annex G):

- i) *No. 1 – Call is not end-to-end ISDN; further call progress information may be available in-band;*
- ii) *No. 2 – Destination address is non-ISDN;*
- iii) *No. 4 – Call has returned to the ISDN.*

If the progress indicator information element is included in a call control message, the procedures as described in the rest of 5.2 apply. If the progress indicator information element is included in the PROGRESS message, no state change will occur but any supervisory timers shall be stopped except network timers T304 and T312.

Superseded by a more recent version

5.2.7 Call accept

A user indicates acceptance of an incoming call by sending a CONNECT message to the network. Upon sending the CONNECT message the user shall start timer T313 (specified in 9.2). If an ALERTING message had previously been sent to the network, the CONNECT message may contain only the call reference.

If a call can be accepted using the B-channel indicated in the SETUP message, and no user alerting is required, a CONNECT message may be sent without a previous ALERTING message.

5.2.8 Active indication

On receipt of the first CONNECT message, the network shall stop (if running) timers T301, T303, T304 and T310; complete the circuit-switched path to the selected B-channel; send a CONNECT ACKNOWLEDGE message to the user which first accepted the call; initiate procedures to send a CONNECT message towards the calling user, and enter the active state.

The CONNECT ACKNOWLEDGE message indicates completion of the circuit-switched connection. There is no guarantee of an end-to-end connection until a CONNECT message is received at the calling user. Upon receipt of the CONNECT ACKNOWLEDGE message the user shall stop timer T313 and enter the active state.

When timer T313 expires prior to receipt of a CONNECT ACKNOWLEDGE message, the user shall initiate clearing in accordance with 5.3.3.

A user which has received the SETUP via the broadcast data link, and has been awarded the call, shall connect to the B-channel only after it has received the CONNECT ACKNOWLEDGE message. Only the user that is awarded the call will receive the CONNECT ACKNOWLEDGE message.

A user which has received the SETUP via a point-to-point data link may connect to the B-channel as soon as channel selection has been completed.

5.2.9 Non-selected user clearing

In addition to sending the CONNECT ACKNOWLEDGE message to the user selected for the call, the network shall send RELEASE message [as described in 5.3.2 b)] to all other users at the interface that have sent SETUP ACKNOWLEDGE, CALL PROCEEDING, ALERTING or CONNECT messages in response to the SETUP message. These RELEASE messages are used to notify the users that the call is no longer offered to them. The procedures described in 5.3.4 are then followed. Any user which having previously sent a CONNECT message and started timer T313, and which subsequently receives a RELEASE message, shall stop timer T313 and follow the procedures of 5.3.4.

5.3 Call clearing

5.3.1 Terminology

The following terms are used in this Recommendation in the description of clearing procedures:

- A channel is *connected* when the channel is part of a circuit-switched ISDN connection established according to this Recommendation.
- A channel is *disconnected* when the channel is no longer part of a circuit-switched ISDN connection, but is not yet available for use in a new connection.
- A channel is *released* when the channel is not part of a circuit-switched ISDN connection and is available for use in a new connection. Similarly, a call reference that is *released* is available for reuse.

5.3.2 Exception conditions

Under normal conditions, call clearing is usually initiated when the user or the network sends a DISCONNECT message and follows the procedures defined in 5.3.3 and 5.3.4 respectively. The only exceptions to the above rule are as follows:

- a) In response to a SETUP message, the user or network can reject a call (e.g. because of the unavailability of a suitable B-channel) by responding with a RELEASE COMPLETE message provided no other response has previously been sent (e.g. the SETUP ACKNOWLEDGE message in the case of overlap sending); releasing the call reference, and enter the Null state.

Superseded by a more recent version

- b) In the case of a multipoint terminal configuration, non-selected user call clearing will be initiated with RELEASE message(s) from the network (see 5.2.9). The RELEASE message shall contain cause No. 26, *non-selected user clearing*.
- c) Clearing of temporary signalling connections will be initiated by sending a RELEASE message as described in 5.3.3 and 5.3.4.
- d) Unsuccessful termination of the B-channel selection procedure (see 5.2.3.1 and 5.1.2) by the side offering the call is accomplished by sending a RELEASE message. The RELEASE message shall contain cause No. 6, *channel unacceptable*. The network and user shall subsequently follow the procedures of 5.3.3 and 5.3.4.
- e)
 - 1) In the case of a SETUP message sent via the broadcast data link, if a network disconnect indication is received during call establishment, and prior to the expiry of timer T312, timer T303 is stopped (if running) and the network enters the Call Abort state. Any user which has responded, or subsequently responds before timer T312 expires, will be cleared by a RELEASE message (with the cause code(s) contained in the network disconnect indication) and the procedures of 5.3.4 are then followed for that user. Upon expiry of timer T312, the network shall treat any subsequent responses according to the procedures defined in 5.8.3.2. The network shall enter the Null state upon completion of clearing procedures for all responding users.
 - 2) In the case of a SETUP message sent via the broadcast data link, if a network disconnect indication is received during call establishment after expiry of timer T312, any user which has responded shall be cleared by a RELEASE message (with the cause code(s) contained in the network disconnect indication) and the procedures of 5.3.4 are then followed for that user. The network enters the Null state upon completion of clearing procedures for all responding users.
- f) When timer T318 expires, the user initiates call clearing by sending a RELEASE message with cause No. 102 “recovery on timer expiry”; starting timer T308, and continuing as described in 5.3.3.

NOTE – A separate state machine exists for each responding user.

5.3.3 Clearing initiated by the user

Apart from the exceptions identified in 5.3.2 and 5.8, the user shall initiate clearing by sending a DISCONNECT message; starting timer T305 (the value of timer T305 is specified in 9.2); disconnecting the B-channel, and entering the disconnect request state.

NOTE 1 – When a user initiates call clearing by sending a RELEASE message, the procedures described in 5.3.4 are then followed.

The network shall enter the Disconnect Request state upon receipt of a DISCONNECT message. This message then prompts the network to disconnect the B-channel, and to initiate procedures for clearing the network connection to the remote user. Once the B-channel used for the call has been disconnected, the network shall send a RELEASE message to the user; start timer T308 (the value of a timer T.308 is specified in 9.1), and enter the Release Request state.

NOTE 2 – The RELEASE message has only local significance and does not imply an acknowledgement of clearing from the remote user.

On receipt of the RELEASE message the user shall cancel timer T305; release the B-channel; send a RELEASE COMPLETE message; release the call reference; and return to the Null state. Following the receipt of a RELEASE COMPLETE message from the user, the network shall stop timer T308; release both the B-channel and the call reference, and return to the Null state.

If timer T305 expires, the user shall send a RELEASE message to the network with the cause number originally contained in the DISCONNECT message; start timer T308 and enter the Release Request state. In addition, the user may indicate a second Cause information element with cause No. 102, *recovery on timer expiry*.

If timer T308 expires for the first time, the network shall retransmit the RELEASE message and timer T308 shall be restarted. In addition, the network may indicate a second Cause information element with cause No. 102, *recovery on timer expiry*. If no RELEASE COMPLETE message is received from the user before timer T308 expires a second time, the network shall place the B-channel in a maintenance condition, release the call reference, and return to the Null state.

Superseded by a more recent version

NOTE 3 – The restart procedures contained in 5.5 may be used on B-channels in the maintenance condition.

NOTE 4 – Other actions which could be taken by the network upon receipt of a DISCONNECT message are for further study.

The actions to be taken with regard to the maintenance condition are network dependent.

5.3.4 Clearing initiated by the network

Apart from the exception conditions identified in 5.3.2 and 5.8, the network shall initiate clearing by sending a DISCONNECT message, and entering the Disconnect Indication state. The DISCONNECT message is a local invitation to clear and does not imply that the B-channel has been disconnected at the user-network interface.

NOTE – When the network initiates clearing by sending a RELEASE message, the procedures described in 5.3.3 are followed.

5.3.4.1 Clearing when tones/announcements provided

When in-band tones/announcements are provided (see 5.4), the DISCONNECT message contains progress indicator No. 8, *in-band information or appropriate pattern now available*. The network shall: start timer T306; and enter the Disconnect Indication state.

On receipt of the DISCONNECT message with progress indicator No. 8, the user may connect (if not already connected) to the B-channel to receive the in-band tone/announcement; and enter the disconnect indication state. Alternatively, to continue clearing without connecting to the in-band tone/announcement, the user shall disconnect the B-channel; send a RELEASE message, start timer T308, and enter the Release Request state.

If the user connects to the provided in-band tone/announcement, the user may subsequently continue clearing (before the receipt of a RELEASE from the network) by disconnecting from the B-channel; sending a RELEASE message; starting timer T308; and entering the Release Request state.

On receipt of the RELEASE message, the network shall stop timer T306; disconnect and release the B-channel; send a RELEASE COMPLETE message; release the call reference, and return to the Null state.

If timer T306 expires, the network shall continue clearing by disconnecting the B-channel; sending a RELEASE message with the cause number originally contained in the DISCONNECT message; starting timer T308, and entering the Release Request state.

In addition to the original clearing cause, the RELEASE message may contain a second cause information element with cause No. 102, *recovery on timer expiry*; this cause may optionally contain a diagnostic field identifying the timer that expired.

On receipt of the RELEASE message, the user shall act according to 5.3.3.

5.3.4.2 Clearing when tones/announcements not provided

When in-band tones/announcements are *not* provided, the DISCONNECT message does *not* contain progress indicator No. 8 *in-band information or appropriate pattern now available*. The network shall initiate clearing by sending the DISCONNECT message; start timer T305; disconnects the B-channel, and enters the Disconnect Indication state.

On the receipt of the DISCONNECT message without progress indicator No. 8, the user shall disconnect the B-channel; send a RELEASE message; start timer T308, and enter the Release Request state.

On receipt of the RELEASE message, the network shall stop timer T305; release the B-channel; send a RELEASE COMPLETE message; release the call reference, and return to the Null state.

If timer T305 expires, the network shall send a RELEASE message to the user with the cause number originally contained in the DISCONNECT message; start timer T308, and enter the Release Request state. In addition to the original clearing cause, the RELEASE message may contain a second Cause information element with cause No. 102, *recovery on timer expiry*.

Superseded by a more recent version

5.3.4.3 Completion of clearing

Following the receipt of a RELEASE COMPLETE message from the network, the user shall stop timer T308; release both the B-channel and the call reference, and return to the Null state.

If a RELEASE COMPLETE is not received by the user before the first expiry of timer T308, the RELEASE message shall be retransmitted and timer T308 shall be restarted. If no RELEASE COMPLETE message is received from the network before timer T308 expires a second time, the user may place the B-channel in a maintenance condition; shall release the call reference, and return to the Null state.

NOTE – The restart procedures contained in 5.5 may be used on B-channels in the maintenance condition.

5.3.5 Clear collision

Clear collision occurs when the user and the network simultaneously transfer DISCONNECT messages specifying the same call reference value. When the network receives a DISCONNECT message whilst in the Disconnect Indication state, the network shall stop timer T305 or T306 (whichever is running); disconnect the B-channel (if not disconnected); send a RELEASE message; start timer T308, and enter the Release Request state. Similarly, when the user receives a DISCONNECT message whilst in the Disconnect Request state, the user shall stop timer T305; send a RELEASE message; start timer T308, and enter the Release Request state.

Clear collision can also occur when both sides simultaneously transfer RELEASE messages related to the same call reference value. The entity receiving such a RELEASE message whilst within the Release Request state shall stop timer T308; release the call reference and B-channel, and enter the Null state (without sending or receiving a RELEASE COMPLETE message).

5.4 In-band tones and announcements

When in-band tones/announcements not associated with a call state change are to be provided by the network before reaching the Active state, a PROGRESS message is returned simultaneously with the application of the in-band tone/announcement. The PROGRESS message contains the progress indicator No. 8, *in-band information or appropriate pattern is now available*.

When tones/announcements have to be provided together with a call state change, then the appropriate message [e.g. for ALERTING, DISCONNECT, etc., (see appropriate section)] with progress indicator No. 8, *in-band information or appropriate pattern is now available* is sent simultaneously with the application of the in-band tone/announcement.

NOTES

1 When the network provides CCITT standardized telecommunications services, the service requirement for provision of in-band tones/announcements is as indicated in the I.200-Series Recommendations.

2 When the PROGRESS message is used, the user may initiate call clearing as a result of the applied in-band tone/announcement, according to the procedures specified in 5.3.3.

3 The protocol currently described in 5.4 applies at the calling user-network interface. The protocol to be applied at the internetwork interface and at the called user-network interface requires further study.

5.5 Restart procedure

The restart procedure is used to return calls to the Null state or the interface to an idle condition. The procedure is usually invoked when the other side of the interface does not respond to other call control messages or a failure has occurred (e.g. following a data link failure, when a backup D-channel can be used, or following the expiry of timer T308 due to the absence of response to a clearing message). It may also be initiated as a result of local failure, maintenance action or mis-operation.

NOTES

1 Layer 3 procedures and resources associated with those data links with SAPI = "0000 000" should be initialized by the restart procedures.

2 The call reference flag of the global call reference applies to restart procedures. In the case when both sides of the interface initiate simultaneous restart requests, they shall be handled independently. In the case when the same channel(s) or interface(s) are specified, they shall not be considered free for reuse until all the relevant restart procedures are completed.

Superseded by a more recent version

When

- a) both the user and the network are aware of the configuration of the interface; and,
- b) the interface is a basic access (Recommendation I.431 [27]) where a point-to-point configuration exists; or
- c) the interface is a primary rate access (Recommendation I.430 [46]);

then the user and the network shall implement the procedures of 5.5. In all other cases, the procedures of 5.5 are optional.

5.5.1 Sending RESTART message

A RESTART message is sent by the network or user equipment in order to return channels or interfaces to the Null state. The Restart indicator information element shall be present in the RESTART message to indicate whether an *Indicated channel*, *Single interface* or *All interfaces* are to be restarted. If the Restart indicator information element is coded as “Indicated channel”, or “Single interface” and the interface is one other than the one containing the D-channel, then the Channel identification information element shall be present to indicate which channel or interface is to be returned to the idle condition. If the Restart indicator information element is coded as “Single interface” and the interface is the one containing the D-channel, then the Channel identification information element may be omitted. If the Restart indicator information element is coded as “All interfaces” then the Channel identification information element shall not be included.

Upon transmitting the RESTART message the sender enters the Restart Request state, starts timer T316, and waits for a RESTART ACKNOWLEDGE message. Also, no further RESTART messages shall be sent until a RESTART ACKNOWLEDGE is received or timer T316 expires. Receipt of a RESTART ACKNOWLEDGE message stops timer T316, frees the channels and call reference values for reuse, and enters the Null state.

If a RESTART ACKNOWLEDGE message is not received prior to the expiry of timer T316 one or more subsequent RESTART messages may be sent until a RESTART ACKNOWLEDGE message is returned. Meanwhile, no calls shall be placed or accepted over the channel or interface by the originator of the RESTART message. A network shall limit the number of consecutive unsuccessful restart attempts to a default limit of two. When this limit is reached, the network shall make no further restart attempts. An indication will be provided to the appropriate maintenance entity. The channel or interface is considered to be in an out-of-service condition until maintenance action has been taken.

NOTE – If a RESTART ACKNOWLEDGE message is received indicating only a subset of the specified channels, an indication shall be given to the maintenance entity. It is the responsibility of the maintenance entity to determine what actions shall be taken on the channel(s) which have not been returned to the idle condition.

The RESTART and RESTART ACKNOWLEDGE message shall contain the global call reference value (all zeros) to which the Restart Request state is associated. These messages are transferred via the appropriate point-to-point data link in the multiple frame mode using the DL-DATA request primitive.

5.5.2 Receipt of RESTART message

Upon receiving a RESTART message the recipient shall enter the Restart state associated to the global call reference and start timer T317; it shall then initiate the appropriate internal actions to return the specified channels to the idle condition and call references to the Null state. Upon completion of internal clearing, timer T317 shall be stopped and a RESTART ACKNOWLEDGE message transmitted to the originator, and the Null state entered.

NOTE 1 – If only a subset of the specified channels have been returned to the idle condition when timer T317 expires, a RESTART ACKNOWLEDGE message should be transmitted to the originator, containing a Channel identification information element indicating the channel(s) that have been returned to the idle condition.

If timer T317 expires prior to completion of internal clearing an indication shall be sent to the maintenance entity (i.e. a primitive should be transmitted to the system management entity).

NOTE 2 – Even if all call references are in the Null state, and all channels are in the idle condition, the receiving entity shall transmit a RESTART ACKNOWLEDGE message to the originator upon receiving a RESTART message.

If the Restart indicator information element is coded as “all interfaces” then all calls on all interfaces associated with the D-channel shall be cleared. If the Restart indicator information element is coded as “all interfaces” and a Channel identification information element is included, the Channel identification information element is treated as described in 5.8.7.3.

If the Restart indicator information element is coded as “indicated channel” and the Channel indication information element is not included, then the procedures in 5.8.6.1 shall be followed.

Superseded by a more recent version

If the Restart indicator information element is coded as “single interface” and that interface includes the D-channel then only those calls associated with the D-channel on that interface shall be cleared.

The receiving DSS1 protocol control entity for the global call reference shall indicate a restart request to only those DSS1 protocol control entities for specific call references which

- a) are supported by the same Data Link Connection Endpoint Identifier (DLCI) (see Recommendation Q.920) as the DSS1 protocol control entity for the global call reference which received the RESTART message; and
- b) correspond to the specified channel(s) or interface(s), or (if the D-channel was implicitly specified) are not associated with any channel, including calls in the call establishment phase for which a channel has not yet been allocated.

The following entities shall be released:

- a) B and H channels established by Q.931 messages including channels used for packet access (case B) (consequently all virtual calls carried in the released channel(s) will be handled as described in 6.4.1);
- b) user signalling bearer service connections.
- c) other resources associated with a call reference, where specified in other DSS1 Recommendations.

NOTE 3 – Application to the Register procedures in Recommendation Q.932 requires further study.

The following entities shall not be released:

- a) semi-permanent connections that are established by man-machine commands;
- b) calls associated with DSS1 protocol control entities supported by any DLCI other than one supporting the DSS1 protocol entity for the global call reference which received the RESTART message;
- c) X.25 virtual calls and permanent virtual circuits using SAPI = 16;
- d) TID and USID values established using terminal initialization procedures (see Annex A/Q.932).

If semi-permanent connections established by man-machine command are implicitly specified (by specifying “single interface or “all interfaces”), no action shall be taken on these channels, but a RESTART ACKNOWLEDGE message shall be returned containing the appropriate indications (i.e. “single interface” or “all interfaces”).

If semi-permanent connections established by man-machine command are explicitly specified (by including a Channel identification information element in the RESTART message) no action shall be taken on these channels, and a STATUS message should be returned with cause No. 82, “*identified channel does not exist*” optionally indicating in the diagnostic field the channel(s) that could not be handled.

5.6 Call rearrangements

The elements of procedure in this subclause provide for physical layer and/or data link layer rearrangements after a call has entered the Active state as defined in 2.2.1.5. The procedure is restricted to use on the same interface structure, and resumption on the same B-channel. The use of call rearrangement procedure is restricted to basic access, i.e. it will not be available for primary rate access. For call rearrangements controlled by an NT2, see 5.6.7.

The activation of this procedure at a user-network interface may correspond to a number of possible events such as the following:

- a) physical disconnection of user equipment and reconnection;
- b) physical replacement of one user equipment by another;
- c) the human user moves from one equipment to another;
- d) suspension of call and its subsequent reactivation at the same user equipment.

These procedures have only local significance, i.e. the invocation of call rearrangement affects only states at the originating end, and it does not affect any terminating states.

Superseded by a more recent version

The procedures in this subsection are described in terms of functional messages and information elements.

If the procedures for call suspension in this subsection are not followed prior to the physical disconnection of the terminal from the interface, then the integrity of the call cannot be guaranteed by the network.

5.6.1 Call suspension

The procedure is initiated by the user, who shall send a SUSPEND message containing the current call reference; start timer T319, and enter the Suspend Request state. The user may optionally include in this message a bit sequence (e.g. IA5 characters) to be known by the application or human user, and by the network, as the call identity for subsequent reconnection. Where no call identity information is included by the user, (e.g. the Call identity information element is absent or empty) the network shall store this fact so that resumption is possible only by a procedure conveying no call identity information.

NOTE – If the Call identity information element is present with a null length, the message shall be handled as if it was absent.

The default maximum length of the call identity value within the Call identity information element is eight octets. If the network receives a call identity value longer than the maximum length supported, the network shall truncate the call identity value to the maximum length; take the action specified in 5.8.7 and continue processing.

5.6.2 Call suspended

Following the receipt of a SUSPEND message the network enters the Suspend Request state. After a positive validation of the received call identity the network shall send a SUSPEND ACKNOWLEDGE message, and start timer T307. (The value of T307 is specified in 9.1.)

At this time, the network shall consider the call reference to be released and enter the Null state for that call reference. The call identity associated with the suspended call has to be stored by the network and cannot be accepted for another suspension until it is released.

The B-channel involved in the connection will be reserved by the network until reconnection of the call (or until a clearing cause occurs, e.g. expiry of timer T307). A NOTIFY message with notification indicator No. 0 (user suspended) is sent to the other user.

When the user receives the SUSPEND ACKNOWLEDGE message, the user shall stop timer T319, release the B-channel and call reference, and enter the Null state.

Following the receipt of the SUSPEND ACKNOWLEDGE message, the user may disconnect the underlying data link connection. In any case, if the user physically disconnects from the interface without having disconnected the data link connection, standard data link layer procedures are started by the network side of the data link layer supervision, resulting in the release of the data link layer connection.

5.6.3 Call suspend error

If the network does not support the call rearrangement procedures, it shall reject a SUSPEND message according to the error handling procedures of 5.8.4. If the network supports the call rearrangement procedures on a subscription basis, but the user does not subscribe to the service, the network shall reject a SUSPEND message with cause No. 50, *requested facility not subscribed*; the Cause information element shall not contain a diagnostic field under these circumstances.

On receipt of a SUSPEND message, the network will respond by sending a SUSPEND REJECT message with cause No. 84, *call identity in use* if the information contained in the SUSPEND message is not sufficient to avoid ambiguities on subsequent call re-establishment. This will apply, in particular, when at a given user-network interface, a SUSPEND message is received with a call identity sequence already in use, or when the SUSPEND message does not contain any call identity sequence and the null-value call identity is already allocated for that interface. On receipt of the SUSPEND REJECT message, the user shall stop timer T319, and return to the active state. If timer T319 expires, the user shall notify the user application and return to the Active state.

In these cases the state of the call is not altered within the network (i.e. it remains in the Active state).

Superseded by a more recent version

5.6.4 Call re-establishment

At the connection end where suspension was initiated, the user may request re-establishment of a call after physical reconnection of a terminal by sending a RESUME message containing the call identity exactly as that used at the time of call suspension; starting timer T318, and entering the Resume Request state. If the SUSPEND message did not include a Call identity information element, then the corresponding RESUME message shall also not include a Call identity information element. The call reference included in the RESUME message is chosen by the user according to the normal allocation of outgoing call reference (see 4.3).

On receipt of a RESUME message, the network enters the Resume Request state. After a positive validation of the call identity that relates to the suspended call containing a valid identity that relates to a currently suspended call, the network shall, send a RESUME ACKNOWLEDGE message to the user; release the call identity; stop timer T307 and enter the Active state. The RESUME ACKNOWLEDGE message shall specify the B-channel reserved to the call by the network by means of the channel identification element, coded *B-channel is indicated, no alternative is acceptable*.

The network shall also send a NOTIFY message with the notification indicated *user resumed* to the other user.

No memory of the previously received call identity sequence is kept by the network after sending the RESUME ACKNOWLEDGE message. This call identity is now available for another suspension.

On receipt of the RESUME ACKNOWLEDGE message, the user shall, stop timer T318 and enter the Active state.

No compatibility is performed during the call arrangement phase.

5.6.5 Call resume errors

If the network does not support the call rearrangement procedures, it shall reject a RESUME message according to the error handling procedures of 5.8.3.2 a). For this purpose, the RESUME message would be deemed to be an unrecognized message.

If a received RESUME message cannot be actioned by the network (e.g. as a result of an unknown call identity, a RESUME REJECT message shall be returned to the requesting user indicating one of the following causes:

- a) No. 83 – *A suspended call exists, but this call identity does not;*
- b) No. 85 – *No call suspended;* or
- c) No. 86 – *Call having the requested call identity has been cleared.*

The call identity remains unknown. The call reference contained in the RESUME message is released by both the user and network side. Upon receipt of the RESUME REJECT message the user shall, stop timer T318, and enter the Null state.

If timer T307 expires the network shall initiate clearing of the network connection with cause No. 102, *recovery on timer expiry*; discard the call identity and release the reserved B-channel.

On release, the call identity can then be used for subsequent call suspension. If before the expiry of timer T307 the call is cleared by the remote user, the B-channel reservation is released but the call identity may be preserved by some networks along with a clearing cause (e.g. cause No. 16, *normal clearing*).

If timer T318 expires, the user shall initiate call clearing in accordance with 5.3.2 f).

5.6.6 Double suspension

Simultaneous suspension of the call at both ends is possible. The procedures do not prevent this from occurring. If double suspensions are not desired the users must protect against this by other means, e.g. higher layer negotiation protocols.

5.6.7 Call re-arrangement notification controlled by an NT2

When the call rearrangement is controlled by the NT2, the procedures shall be applied by the NT2 at reference point S. The NT2 shall inform the remote user by sending a NOTIFY message described in 5.6.2 and 5.6.4 across reference point T.

Superseded by a more recent version

5.7 Call collisions

Call collisions as such cannot occur at the network. Any simultaneous incoming or outgoing calls are dealt with separately and assigned different call references.

Channel selection conflicts may occur if an incoming call and outgoing call select the same channel. This is resolved by the network through channel selection mechanisms described in 5.1.2 and 5.2.2.

In the case of such conflicts, the network shall give priority to the incoming call over the call request received from the user. It shall clear the outgoing call whenever the B-channel cannot be allocated by the network or accepted by the user originating the call.

NOTE – Some terminal adaptors supporting existing non-voice terminals (e.g. Recommendation X.21) may need to resolve double channel selection by clearing the incoming call and reattempting the outgoing call setup in order to satisfy the requirements of the interface at reference point R.

5.8 Handling of error conditions

All procedures transferring signalling information by using the protocol discriminator of Q.931 user-network call control messages are applicable only to those messages which pass the checks described in 5.8.1 through 5.8.7. The error handling procedures of 5.8.1 through 5.8.7 apply to messages using an ordinary call reference or the global call reference, except where otherwise noted.

Detailed error handling procedures are implementation dependent and may vary from network to network. However, capabilities facilitating the orderly treatment of error conditions are provided for in this section and shall be provided in each implementation.

Subclauses 5.8.1 through 5.8.7 are listed in order of precedence.

5.8.1 Protocol discrimination error

When a message is received with a protocol discriminator coded other than *Q.931 user-network call control message*, that message shall be ignored, means to do nothing, as if the message had never been received.

5.8.2 Message too short

When a message is received that is too short to contain a complete message type information element, that message shall be ignored.

5.8.3 Call reference error

5.8.3.1 Invalid Call reference format

If the Call reference information element octet 1, bits 5 through 8 do not equal 0000, then the message shall be ignored.

If the Call reference information element octet 1, bits 1 through 4 indicate a length greater than the maximum length supported by the receiving equipment (see 4.3), then the message shall be ignored.

When a message is received with the dummy call reference it shall be ignored unless it is required for a supplementary service (see Recommendation Q.932 [4]).

5.8.3.2 Call reference procedural errors

Only item f) applies to messages using the global call reference.

- a) Whenever any message except SETUP, RELEASE, RELEASE COMPLETE, STATUS, STATUS ENQUIRY or (for networks supporting the call rearrangement procedures of 5.6) RESUME is received specifying a call reference which it does not recognize as relating to an active call or a call in progress, clearing is initiated by sending a RELEASE message with cause No. 81, "invalid call reference value" and following the procedures in 5.3, specifying the call reference in the received message.

Alternatively, the receiving entity may send a RELEASE COMPLETE message with cause No. 81, "invalid call reference value" and remain in the Null state.

Superseded by a more recent version

- b) When a RELEASE message is received that specified a call reference which is not recognized as relating to an active call or a call in progress, a RELEASE COMPLETE message with cause No. 81, “invalid call reference value” is returned, specifying the call reference in the received message.
- c) When a RELEASE COMPLETE message is received specifying a call reference which it does not recognize as relating to an active call or a call in progress, no action should be taken.
- d) When a SETUP or RESUME message is received specifying a call reference which is recognized as relating to an active call or to a call in progress, and with a call reference flag incorrectly set to “1”, that message shall be ignored.
- e) When a SETUP message is received specifying a call reference which is recognized as relating to an active call, or a call in progress, this SETUP message shall be ignored.
- f) When any message except RESTART, RESTART ACKNOWLEDGE, or STATUS is received using the global call reference, no action should be taken on this message and a STATUS message using the global call reference with a call state indicating the current state associated with the global call reference and cause No. 81 “invalid call reference value” shall be returned.
- g) When a STATUS message is received specifying a call reference which is not recognized as relating to an active call or to a call in progress, the procedures of 5.8.11 shall apply.
- h) When a STATUS ENQUIRY message is received specifying a call reference which is not recognized as relating to an active call or to a call in progress, the procedures of 5.8.10 shall apply.

NOTE – Some implementations conforming to Recommendation Q.931 (1988) may choose to initiate clearing by sending a RELEASE message with cause No. 81 *invalid call reference value* and continue to follow the procedures in 5.3, specifying the call reference in the received message, or respond with a RELEASE COMPLETE message with cause No. 81, *invalid call reference value* and remain in the Null state.

5.8.4 Message type or message sequence errors

Whenever an unexpected message, except RELEASE or RELEASE COMPLETE, or unrecognized message is received in any state other than the Null state, a STATUS message shall be returned with cause No. 98, *message not compatible with call state or message type non-existent or not implemented* and the corresponding diagnostic. If a network or user can distinguish between unimplemented (or non-existent) message types and implemented message types which are incompatible with the call state, then a STATUS message may be sent with one of the following causes:

- a) cause No. 97 *message type non-existent or not implemented*; or
- b) cause No. 101 *message not compatible with call state*.

Alternatively, a STATUS ENQUIRY message may be sent requesting the call state of the entity (see 5.8.10). No change in state shall be made in either case at this time. This alternative is not applicable to messages using the global call reference.

However, two exceptions to this procedure exist. The first exception is when the network or the user receives an unexpected RELEASE message (e.g. if the DISCONNECT message was corrupted by undetected transmission errors). In this case no STATUS or STATUS ENQUIRY message is sent. Whenever the network receives an unexpected RELEASE message, the network shall disconnect and release the B-channel; clear the network connection and the call to the remote user with the cause in the RELEASE message sent by the user or, if not included, cause No. 31, *normal, unspecified*; return a RELEASE COMPLETE message to the user; release the call reference, stop all timers and enter the Null state. Whenever the user receives an unexpected RELEASE message, the user shall disconnect and release the B-channel; return a RELEASE COMPLETE message to the network; release the call reference; stop all timers, and enter the Null state.

The second exception is when the network or the user receives an unexpected RELEASE COMPLETE message. Whenever the network receives an unexpected RELEASE COMPLETE message, the network shall disconnect and release the B-channel; clear the network connection and the call to the remote user with the cause indicated by the user or, if not included, cause No. 111, *protocol error, unspecified*; release the call reference; stop all timers and enter the Null state. Whenever the user receives an unexpected RELEASE COMPLETE message, the user shall disconnect and release the B-channel; release the call reference; stop all timers, and enter the Null state.

Superseded by a more recent version

5.8.5 General information element errors

The general information element error procedures may also apply to information elements in codesets other than 0. In that case, the diagnostics in the cause information element may indicate information elements other than those in codeset 0 by applying the locking or non-locking shift procedures as described in 4.5.

5.8.5.1 Information element out of sequence

A variable length information element which has a code value lower than the code value of the variable length information element preceding it shall be considered as an out of sequence information element.

If the network or user receives a message containing an out of sequence information element, it may ignore this information element and continue to process the message. If this information is mandatory, and the network or user chooses to ignore this out of sequence information element, then the error handling procedure for missing mandatory information elements as described in 5.8.6.1 shall be followed. If the ignored information element is non-mandatory, the receiver continues to process the message.

NOTE – Some implementations may choose to process all the information elements received in a message regardless of the order in which they are placed.

5.8.5.2 Duplicated information elements

If an information element is repeated in a message in which repetition of the information element is not permitted, only the contents of information element appearing first shall be handled and all subsequent repetitions of the information element shall be ignored. When repetition of information elements is permitted, only the contents of permitted information elements shall be handled. If the limit on repetition of information elements is exceeded, the contents of information elements appearing first up to the limit of repetitions shall be handled and all subsequent repetitions of the information element shall be ignored.

5.8.6 Mandatory information element errors

5.8.6.1 Mandatory information element missing

When a message other than SETUP, DISCONNECT, RELEASE or RELEASE COMPLETE is received which has one or more mandatory information elements missing, no action should be taken on the message and no state change should occur. A STATUS message is then returned with cause No. 96, *mandatory information element is missing*.

When a SETUP or RELEASE message is received which has one or more mandatory information elements missing, a RELEASE COMPLETE message with cause No. 96, *mandatory information element is missing* shall be returned.

When a DISCONNECT message is received with the cause information element missing, the actions taken shall be the same as if a DISCONNECT message with cause No. 31, *normal, unspecified* was received (see 5.3), with the exception that the RELEASE message sent on the local interface contains cause No. 96, *mandatory information element is missing*.

When a RELEASE COMPLETE message is received with a cause information element missing, it will be assumed that a RELEASE COMPLETE message was received with cause No. 31, *normal, unspecified*.

5.8.6.2 Mandatory information element content error

When a message other than SETUP, DISCONNECT, RELEASE, or RELEASE COMPLETE is received which has one or more mandatory information elements with invalid content, no action should be taken on the message and no state change should occur. A STATUS message is then returned with cause No. 100, “invalid information element contents”.

When a SETUP or RELEASE message is received which has one or more mandatory information elements with invalid content, a RELEASE COMPLETE message with cause No. 100, “invalid information element contents” shall be returned.

When a DISCONNECT message is received with invalid content of the Cause information element, the actions shall be the same as if a DISCONNECT message with cause No. 31, “normal, unspecified” was received (see 5.3), with the exception that the RELEASE message sent on the local interface contains cause No. 100, “invalid information element contents”.

Superseded by a more recent version

When a RELEASE COMPLETE message is received with invalid content of the Cause information element, it will be assumed that a RELEASE COMPLETE message was received with cause No. 31, “normal, unspecified”.

Information elements with a length exceeding the maximum length (given in 3) shall be treated as an information element with content error.

NOTE – As an option of the user equipment (e.g. NT2), cause values, location codes, and diagnostics which are not understood by the NT2 may be passed on to another entity (e.g. user or NT2) instead of treating the cause value as if it were cause No. 31, *normal, unspecified* and sending cause No. 100, *invalid information element contents* with the RELEASE message. This option is intended to aid user equipment to be compatible with future additions of cause values, location codes and diagnostics to the Recommendation.

5.8.7 Non-mandatory information element errors

The following subclauses identify actions on information elements not recognized as mandatory.

5.8.7.1 Unrecognized information element

When a message is received which has one or more unrecognized information elements, the receiving entity shall check whether any are encoded to indicate “comprehension required” (refer to Table 4-3/Q.931 for information element identifiers reserved with this meaning). If any unrecognized information element is encoded to indicate “comprehension required” then the procedures in 5.8.6.1 are followed, i.e. as if a “missing mandatory information element” error condition had occurred. If all unrecognized information elements are **not** encoded to indicate “comprehension required”, then the receiving entity shall proceed as follows:

Action shall be taken on the message and those information elements which are recognized and have valid content. When the received message is other than DISCONNECT, RELEASE or RELEASE COMPLETE, a STATUS message may be returned containing one cause information element. The STATUS message indicates the call state of the receiver after taking action on the message. The Cause information element shall contain cause No. 99, “information element non-existent or not implemented”, and the diagnostic field, if present, shall contain the information element identifier for each information element which was unrecognized.

Subsequent actions are determined by the sender of the unrecognized information elements. If a clearing message contains one or more unrecognized information elements, the error is reported to the local user in the following manner:

- a) When a DISCONNECT message is received which has one or more unrecognized information elements, a RELEASE message with cause No. 99, “information element non-existent or not implemented”, shall be returned. The Cause information element diagnostic field, if present, shall contain the information element identifier for each information element which was unrecognized.
- b) When a RELEASE message is received which has one or more unrecognized information elements, a RELEASE COMPLETE message with cause No. 99 “information element non-existent or not implemented”, shall be returned. The Cause information element diagnostic field, if present, shall contain the information element identifier for each information element which was unrecognized.
- c) When a RELEASE COMPLETE message is received which has one or more unrecognized information elements, no action shall be taken on the unrecognized information.

NOTE – The diagnostic(s) of cause No. 99 facilitates the decision in selecting an appropriate recovery procedure at the reception of a STATUS message. Therefore, it is recommended to provide cause No. 99 with diagnostic(s) if a layer 3 entity expects the peer to take an appropriate action at the receipt of a STATUS message, although inclusion of diagnostic(s) is optional.

5.8.7.2 Non-mandatory information element content error

When a message is received which has one or more non-mandatory information elements with invalid content, action shall be taken on the message and those information elements which are recognized and have valid content. A STATUS message may be returned containing one Cause information element. The STATUS message indicates the call state of the receiver after taking action on the message. The Cause information element shall contain cause No. 100 “invalid information element contents”, and the diagnostic field, if present, shall contain the information element identifier for each information element which has invalid contents.

Superseded by a more recent version

Information elements with a length exceeding the maximum length (given in 3) will be treated as an information element with content error. But for access information elements (e.g. User-user information element, Called party subaddress information element), cause No. 43, “access information discarded” is used instead of cause No. 100 “invalid information element contents”. However, in some networks, access information elements may be truncated and processed.

The Call identity information element shall have a special treatment and shall be truncated and processed in the case that it exceeds the maximum length implemented.

NOTE – As an option of user equipment (e.g. NT2), cause values, location codes, and diagnostics which are not understood by the NT2 may be accepted, or in the case of an NT2, passed on to another entity (e.g. user or NT2) instead of ignoring the cause information element contents and optionally sending a STATUS message with cause No. 100, *invalid information element contents*. This option is intended to aid user equipment to be compatible with future additions of cause values, location codes and diagnostics to the Recommendation.

5.8.7.3 Unexpected recognized information element

When a message is received with a recognized information element that is not marked as comprehension required and is not defined to be contained in that message, the receiving entity shall (except as noted below) treat the information element as an unrecognized information element and follow the procedures defined in 5.8.7.1. When a message is received with a recognized information element that is marked as comprehension required and is not defined to be contained in that message, the receiving entity shall follow the procedures of 5.8.6.1.

NOTE – Some implementations may choose to process unexpected recognized information elements when the procedure for processing the information element is independent of the message in which it is received.

5.8.8 Data link reset

Whenever a Q.931 entity is informed of a spontaneous data link layer reset by means of the DL-ESTABLISH indication primitive, the following procedures apply:

- a) For calls in the Overlap Sending and Overlap Receiving states, the entity shall initiate clearing by sending a DISCONNECT message with cause No. 41, *temporary failure*, and following the procedures of 5.3.
- b) For calls in the disestablishment phase (states N11, N12, N19, N22, U11, U12 and U19), no action shall be taken.
- c) Calls in the establishment phase (states N1, N3, N4, N6, N7, N8, N9, U1, U3, U4, U6, U7, U8 and U9) and in the Active, Suspend Request, and Resume Request states shall be maintained according to the procedures contained in other parts of 5.

5.8.9 Data link failure

Whenever the network layer entity is notified by its data link layer entity via the DL-RELEASE indication primitive that there is a data link layer malfunction, the following procedure shall apply:

- a) Any calls not in the Active state shall be cleared internally.
- b) For any call in the Active state a timer T309 shall be started (if implemented).

If timer T309 is already running, it shall not be restarted.

The Q.931 entity shall request layer 2 reestablishment by sending a DL-ESTABLISH request primitive.

When informed of layer 2 re-establishment by means of the DL-ESTABLISH confirmation primitive, the following procedure shall apply:

the Q.931 entity shall stop timer T309, and either:

- the Q.931 entity shall send a STATUS message with cause No. 31, *normal, unspecified* to report the current state to the peer entity; or
- the Q.931 entity shall perform the status enquiry procedure according to 5.8.10 to verify the call state of the peer entity.

If timer T309 expires prior to data link reestablishment, the network shall clear the network connection and call to the remote user with cause No. 27, *destination out of order*; disconnect and release the B-channel; release the call reference, and enter the Null state.

If timer T309 expires prior to data link reestablishment, the user shall clear the attached connection (if any) with cause No. 27, *destination out of order*; disconnect and release the B-channel; release the call reference, and enter the Null state.

When a back-up D-channel is available, the procedures in Annex F may be used.

Superseded by a more recent version

The implementation of timer T309 in the user side is optional and in the network side is mandatory.

When a Q.931 entity internally clears the call as a result of data link failure, as an option, it may request the reestablishment of the data link in order to attempt to send a DISCONNECT message across the interface.

5.8.10 Status enquiry procedure

Whenever an entity wishes to check the correctness of a call state at a peer entity, a STATUS ENQUIRY message may be sent requesting the call state. This may, in particular, apply to procedural error conditions described in 5.8.8 and 5.8.9.

Upon sending the STATUS ENQUIRY message, timer T322 shall be started in anticipation of receiving a STATUS message. While timer T322 is running, only one outstanding request for call state information shall exist. Therefore, if timer T322 is already running, it shall not be restarted. If a clearing message is received before timer T322 expires, timer T322 shall be stopped, and call clearing shall continue.

Upon receipt of a STATUS ENQUIRY message, the receiver shall respond with a STATUS message, reporting the current call state (the current state of an active call or a call in progress, or the Null state if the call reference does not relate to an active call or to a call in progress) and cause No. 30, *response to STATUS ENQUIRY* or No. 97, *message type non-existent or not implemented* (see 5.8.4). Receipt of the STATUS ENQUIRY message does not result in a state change.

The sending or receipt of the STATUS message in such a situation will not directly affect the call state of either the sender or receiver. The side having received the STATUS message shall inspect the Cause information element. If the STATUS message contains cause No. 97, *message type non-existent or not implemented*, timer T322 shall continue to time for an explicit response to the STATUS ENQUIRY message. If a STATUS message is received that contains cause No. 30, *response to status enquiry*, timer T322 shall be stopped and the appropriate action taken, based on the information in that STATUS message, relative to the current state of the receiver. If timer T322 expires and a STATUS message with cause No. 97, *message type non-existent or not implemented* was received, the appropriate action shall be taken, based on the information in that STATUS message, relative to the current call state of the receiver.

These further *appropriate actions* are implementation dependent. However, the actions prescribed in the following subclause shall apply.

If timer T322 expires, and no STATUS message was received, the STATUS ENQUIRY message may be retransmitted one or more times until a response is received. The number of times the STATUS ENQUIRY message is retransmitted as an implementation dependent value. The call shall be cleared to the local interface with cause No. 41, *temporary failure*, if the STATUS ENQUIRY is retransmitted the maximum number of times. If appropriate, the network shall also clear the network connection, using cause No. 41, *temporary failure*.

5.8.11 Receiving a STATUS message

On receipt of a STATUS message reporting an incompatible state, the receiving entity shall

- a) clear the call by sending the appropriate clearing message with cause No. 101, *message not compatible with call state*; or
- b) take other actions which attempt to cover from a mismatch and which are an implementation option.

Except for the following rules, the determination of which states are incompatible is left as an implementation decision:

- a) If a STATUS message indicating any call state except the Null state is received in the Null state, then the receiving entity shall either
 - 1) send a RELEASE message with cause No. 101, *message not compatible with call state*, and then follow the procedures of 5.3; or
 - 2) send a RELEASE COMPLETE message with cause No. 101, *message not compatible with call state*; and remain in the Null state.

Superseded by a more recent version

- b) If a STATUS message indicating any call state except the Null state is received in the release request state, no action shall be taken.
- c) If a STATUS message, indicating the Null state, is received in any state except the Null state, the receiver shall release all resources and move into the Null state.

When in the Null state, the receiver of a STATUS message indicating the Null state shall take no action other than to discard the message and shall remain in the Null state.

A STATUS message may be received indicating a compatible call state but containing one of the following causes:

- i) No. 96 – *Mandatory information element is missing;*
- ii) No. 97 – *Message type non-existing or not implemented;*
- iii) No. 99 – *Information element non-existent or not implemented;* or
- iv) No. 100 – *Invalid information element contents.*

In this case the actions to be taken are an implementation option. If other procedures are not defined, the receiver shall clear the call with the appropriate procedure defined in 5.3, using the cause specified in the received STATUS message.

On receipt of a STATUS message specifying the global call reference and reporting an incompatible state in the restart request or restart state, the receiving Q.931 entity shall inform layer management and take no further action on this message.

When in the Null state, then on receipt of a STATUS message with the global call reference no action shall be taken.

NOTE – Further actions as a result of higher layer activity (e.g. system or layer management) and implementation dependent (including the retransmission of RESTART).

Except for the above case, the error handling procedures when receiving a STATUS message specifying the global call reference are an implementation option.

5.9 User notification procedure

This procedure allows the network to notify a user of any appropriate call-related event during the active state of a call. It also allows a user to notify the remote user of any appropriate call-related event during the active state of a call by sending a NOTIFY message containing a notify indicator to the network; upon receipt of this message, the network must send a NOTIFY message containing the same notify indicator to the other user involved in the call. No state change occurs at any of the interface sides following the sending or the receipt of this message.

5.10 Basic telecommunication service identification and selection

Procedures for bearer capability selection are described in 5.11 and procedures for high layer compatibility selection are described in 5.12.

When these procedures are used, the user shall ensure that the first High layer compatibility information element shall be compatible with the first Bearer capability information element.

For teleservices, the network and the destination user shall identify the requested teleservices by taking the presented Bearer capability and High layer compatibility information elements in all combinations. Where a permutation is not defined as a legal basic telecommunications service, that permutation shall be ignored. Where a permutation is defined as a legal basic telecommunications service, that permutation may be considered for the purposes of service provision.

For bearer services, the High layer compatibility information element, if included, does not identify a supported teleservice and the contents of the High layer compatibility information element is not used by the network. The network and the destination user shall identify the requested bearer services from the values of the presented Bearer capability information elements.

NOTES

1 Each basic telecommunication service will have the required Bearer capability information element encodings, and if applicable, the required High layer compatibility information element encodings, defined for that service.

2 These requirements do not preclude the user performing compatibility checking on all compatibility information according to Annex B.

Superseded by a more recent version

5.11 Signalling procedures for bearer capability selection

The procedures in this subclause form an optional part of this Recommendation, but are a mandatory requirement for the provision of certain bearer services or teleservices. Provision of these procedures between the originating user and the originating network, and also between the destination network and the destination user, is thus subject to bilateral agreement, e.g. a subscription arrangement for the provision of that bearer service or teleservice to each user.

These procedures shall apply only in the case where the call, or call request, as currently routed, is entirely within the ISDN. It will not apply to situations involving interworking with non-ISDNs.

NOTE – The use of the Low layer compatibility information element in conjunction with these procedures requires further study and the interpretation of any received Low layer compatibility information element is not defined.

5.11.1 Procedures for the originating user to indicate bearer capability selection is allowed

5.11.1.1 Normal operation

For some bearer services or teleservices, the originating user can indicate that

- fallback to an alternative bearer capability is allowed; or
- fallback to an alternative bearer capability is not allowed.

If the calling user allows fallback to occur to an alternative bearer capability, then the user shall indicate this to the network by means of repeated Bearer capability information elements within the SETUP message sent to indicate the presence of a call request. This procedure allows a maximum of two Bearer capability information elements in the SETUP message.

The order of the information elements shall indicate the priority of the bearer capabilities. Bearer capability information elements shall be in ascending order of priority, i.e. a subsequent Bearer capability information element shall indicate a bearer capability with higher priority.

If fallback allowed is indicated in the SETUP message as described above, and fallback occurs at the destination user, or fallback does not occur, the originating network shall include in the CONNECT message sent to the calling user the Bearer capability information element of the resultant bearer service or teleservice.

If fallback allowed is indicated in the SETUP message as described above, and fallback occurs within the ISDN (e.g. bearer capability selection is not supported or the selected route does not support the preferred bearer capability), the originating network shall include in a PROGRESS message or other appropriate call control message sent to the calling user a Progress indicator information element with the progress description No. 5, *interworking has occurred and has resulted in a telecommunication service change*. The originating network shall include the Bearer capability information element of the resultant bearer service or teleservice.

5.11.1.2 Exceptional procedures

The procedures of 5.8 shall apply, with the addition that

- a) If the calling user receives no Bearer capability information element in the CONNECT message, or prior to the CONNECT message in some other call control message, the user shall assume that the bearer service or teleservice corresponds to the first Bearer capability information element that the user included in the SETUP message.
- b) If the calling user receives a Progress indicator information element with a progress description No. 1, *call is not end-to-end ISDN, further call progress information may be available in-band* or progress description No. 2, *destination address is non-ISDN* subsequent to a Progress indicator information element with a progress description No. 5, *interworking has occurred and has resulted in a telecommunication service change*, then the last received Progress indicator information element shall be taken account of. Where the progress description is No. 1, *call is not end-to-end ISDN, further call progress information may be available in-band* or progress description is No. 2, *destination address is non-ISDN* the user shall assume a bearer service category of circuit-mode 64 kbit/s 8 kHz structured usable for 3.1 kHz audio information transfer.

Superseded by a more recent version

5.11.2 Procedures for bearer capability selection at the destination side

5.11.2.1 Normal operation

If the calling user and the network operator allow fallback to occur to an alternative bearer capability, then the destination network shall indicate this to the destination user by means of repeated Bearer capability information elements within the SETUP message sent to indicate the presence of a call request.

The order of the information elements shall indicate the priority of the bearer capabilities. Bearer capability information elements shall be in ascending order of priority, i.e. a subsequent Bearer capability information element shall indicate a bearer capability with higher priority.

If fallback allowed is indicated in the SETUP message as described above, and the user wishes to accept the call without having fallback occur, the user shall include in the CONNECT message sent to the network the Bearer capability information element of the requested bearer service or teleservice.

If fallback allowed is indicated in the SETUP message as described above, and the user wishes to accept the call with having fallback occur to the lowest priority alternative bearer capability, the user may, but need not, include in the CONNECT message sent to the network the Bearer capability information element of the alternative bearer service or teleservice.

If no Bearer capability information element is indicated by the called user, the network shall assume that the lowest priority bearer capability is selected.

If fallback allowed is indicated in the call request, and no interworking has been encountered (i.e. a progress description No. 1, *call is not end-to-end ISDN, further call progress information may be available in-band* or progress description No. 2, *destination address is non-ISDN* has not been sent), the destination network shall indicate the resultant bearer capability and connection type to the originating network at the time the bearer is established, even if no Bearer capability information element is received from the destination user.

5.11.2.2 Exceptional procedures

The procedures of 5.8 shall apply.

5.11.3 Procedures for interworking with private ISDNs

5.11.3.1 Procedures for the originating user to indicate bearer capability selection is allowed

The procedures of 5.11.1 shall apply.

5.11.3.2 Procedures for bearer capability selection at the destination side of a public ISDN

5.11.3.2.1 Normal operation

If a private ISDN is attached to the access at the destination interface, the following procedures are applicable at call request. The private ISDN acts as the called user.

If the calling user allows fallback to occur to an alternative bearer capability, then the network shall indicate this to the called user by means of repeated Bearer capability information elements within the SETUP message sent to indicate the presence of a call request.

The order of the information elements shall indicate the priority of the bearer capabilities. Bearer capability information elements shall be in ascending order of priority, i.e. a subsequent Bearer capability information element shall indicate a bearer capability with higher priority.

If fallback allowed is indicated in the SETUP message as described above, and fallback occurs at the destination user (beyond the private ISDN) or fallback does not occur, the user shall include in the CONNECT message sent to the network the Bearer capability information element of the resultant bearer service or teleservice.

If fallback allowed is indicated in the SETUP message as described above, and fallback occurs within the private ISDN, the user shall include in a PROGRESS message or other appropriate call control message sent to the network a Progress indicator information element with a progress description No. 5, *interworking has occurred and has resulted in a telecommunication service change*. The user shall include the Bearer capability information element of the resultant bearer service or teleservice.

Superseded by a more recent version

5.11.3.2.2 Exceptional procedures

The procedures of 5.8 shall apply, with the addition that

- a) If the network receives no Bearer capability information element in the CONNECT message, or prior to the CONNECT message in some other call control message, the network shall assume that the bearer service or teleservice corresponds to the first Bearer capability information element that the network included in the SETUP message.

NOTE – In addition, a progress description No. 5 shall be returned to the calling user in the CONNECT message, unless a progress description No. 1 or No. 2 is returned in the CONNECT message. The lowest priority Bearer capability information element is also returned in the CONNECT message (see 5.11.1.1).

- b) If the network receives a Progress indicator information element with a progress description No. 1, *call is not end-to-end ISDN, further call progress information may be available in-band* or progress description No. 2, *destination address is non-ISDN* subsequent to a Progress indicator information element with a progress description No. 5 *interworking has occurred and has resulted in a telecommunication service change*, then the last received Progress indicator information element shall be taken account of. Where the progress description is No. 1 *call is not end-to-end ISDN, further call progress information may be available in-band* or the progress description is No. 2 *destination address is non-ISDN* the network shall assume a bearer service category of circuit-mode 64 kbit/s 8 kHz structured usable for 3.1 kHz audio information transfer.

5.12 Signalling procedures for high layer compatibility selection

The procedures in this subclause form an optional part of this Recommendation, but are a mandatory requirement for the provision of certain teleservices. Provision of these procedures between the originating user and the originating network, and also between the destination network and the destination user is thus subject to bilateral agreement, e.g. a subscription arrangement for the provision of that teleservice to each user.

These procedures shall apply only in the case where the call, or call request, as currently routed, is entirely within the ISDN. It will not apply to situations involving interworking with non-ISDNs.

5.12.1 Procedures for the originating user to indicate high layer compatibility selection is allowed

5.12.1.1 Normal operation

In some networks, the originating user can indicate that

- fallback to an alternative high layer compatibility is allowed; or
- fallback to an alternative high layer compatibility is not allowed.

If the calling user allows fallback to occur to an alternative high layer compatibility, then the user shall indicate this to the network by means of repeated High layer compatibility information elements within the SETUP message sent to indicate the presence of a call request. This procedure allows a maximum of two High layer compatibility information elements in the SETUP message.

The order of the information elements shall be in ascending order of priority, i.e. a subsequent High layer compatibility information element shall indicate a high layer compatibility with higher priority.

If fallback allowed is indicated in the SETUP message as described above, and fallback occurs at the destination user, or fallback does not occur, the originating network shall include in the CONNECT message sent to the calling user the High layer compatibility information element of the resultant high layer compatibility.

If fallback allowed is indicated in the SETUP message as described above, and fallback occurs within the ISDN, the originating network shall include in a PROGRESS message or other appropriate call control message sent to the calling user a Progress indicator information element with the progress description No. 5 *interworking has occurred and has resulted in a telecommunication service change*. The originating network shall include the High layer compatibility information element of the resultant high layer compatibility.

Superseded by a more recent version

5.12.1.2 Exceptional procedures

The procedures of 5.8 shall apply, with the addition that

- a) If the calling user receives no High layer compatibility information element in the CONNECT message, or prior to the CONNECT message in some other call control message, the user shall assume that the high layer compatibility is unknown.

NOTE – It may be possible to subsequently identify the high layer compatibility from any in-band protocol within the B-channel.

- b) If the calling user receives a Progress indicator information element with a progress description No. 1 *call is not end-to-end ISDN, further call progress information may be available in-band* or progress description No. 2 *destination address is non-ISDN* subsequent to a Progress indicator information element with a progress description No. 5 *interworking has occurred and has resulted in a telecommunication service change*, then the last received Progress indicator information element shall be taken account of. Where the progress description is No. 1 *call is not end-to-end ISDN, further call progress information may be available in-band* or progress description is No. 2 *destination address is non-ISDN* the user shall assume a bearer service category of circuit-mode 64 kbit/s 8 kHz structured usable for 3.1 kHz audio information transfer.

5.12.2 Procedures for high layer compatibility selection at the destination side

5.12.2.1 Normal operation

If the calling user and the network operator allow high layer compatibility selection, then the destination network shall indicate this to the destination user by means of repeated High layer compatibility information elements within the SETUP message sent to indicate the presence of a call request.

The order of the information elements shall be in ascending order of priority, i.e. a subsequent High layer compatibility information element shall indicate a high layer compatibility with higher priority.

If fallback allowed is indicated in the SETUP message as described above, and the user wishes to accept the call without having fallback occur, the user shall include in the CONNECT message sent to the network the High layer compatibility information element of the requested high layer compatibility.

If fallback allowed is indicated in the SETUP message as described above, and the user wishes to accept the call with having fallback occur to the lowest priority alternative high layer compatibility, the user may, but need not, include in the CONNECT message sent to the network the High layer compatibility information element of the alternative high layer compatibility.

If no High layer compatibility information element is indicated by the called user, the network shall assume that the lowest priority high layer compatibility is selected.

If fallback allowed is indicated in the call request, and no interworking has been encountered (i.e. a progress description No. 1, *call is not end-to-end ISDN, further call progress information may be available in-band* or progress description No. 2, *destination address is non-ISDN* has not been sent), then the destination network shall indicate the resultant high layer compatibility to the originating network at the time the bearer is established, even if no High layer compatibility information element is received from the destination user.

5.12.2.2 Exceptional procedures

The procedures of 5.8 shall apply.

5.12.3 Procedures for interworking with private ISDNs

5.12.3.1 Procedures for the originating user to indicate high layer compatibility selection is allowed

The procedures of 5.12.1 shall apply.

Superseded by a more recent version

5.12.3.2 Procedures for high layer compatibility selection at the destination side of a public ISDN

5.12.3.2.1 Normal operation

If a private ISDN is attached to the access at the destination interface, the following procedures are applicable at call request. The private ISDN acts as the called user.

If the calling user allows fallback to occur to an alternative high layer compatibility, then the network shall indicate this to the called user by means of repeated High layer compatibility information elements within the SETUP message sent to indicate the presence of a call request.

The order of the information elements shall be in ascending order of priority, i.e. a subsequent High layer compatibility information element shall indicate a high layer compatibility with higher priority.

If fallback allowed is indicated in the SETUP message as described above, and fallback occurs at the destination user (beyond the private ISDN) or fallback does not occur, the user shall include in the CONNECT message sent to the network the High layer compatibility information element of the resultant high layer compatibility.

If fallback allowed is indicated in the SETUP message as described above, and fallback occurs within the private ISDN, the user shall include in a PROGRESS message or other appropriate call control message sent to the network a Progress indicator information element with a progress description No. 5, *interworking has occurred and has resulted in a telecommunication service change*. The user shall include the High layer compatibility information element of the resultant high layer compatibility.

5.12.3.2.2 Exceptional procedures

The procedures of 5.8 shall apply, with the addition that

- a) If the network receives no High layer compatibility information element in the CONNECT message, or prior to the CONNECT message in some other call control message, the network shall assume that the high layer compatibility is unknown.

NOTE – It may be possible to subsequently identify the high layer compatibility from any in-band protocol within the B-channel.

- b) If the network receives a Progress indicator information element with a progress description No. 1 *call is not end-to-end ISDN, further call progress information may be available in-band* or progress description No. 2 *destination address is non-ISDN* subsequent to a Progress indicator information element with a progress description No. 5 *interworking has occurred and has resulted in a telecommunication service change*, then the last received Progress indicator information element shall be taken account of. Where the progress description is No. 1 *call is not end-to-end ISDN, further call progress information may be available in-band* or progress description is No. 2 *destination address is non-ISDN* the network shall assume a bearer service category of circuit-mode 64 kbit/s 8 kHz structured usable for 3.1 kHz audio information transfer.

6 Packet communication procedures

This clause is intended to explain the role of the D-channel signalling procedures in the support of packet communications in an ISDN. A complete description of terminal adaptor functions can be found in Recommendation X.31 [14].

According to Recommendation X.31, the user may access packet facilities by means of one of the following alternatives:

- a) *Circuit-switched access to PSPDN services (Case A)*

by establishing a transparent circuit-switched access connection through the ISDN to the access port of a public network (e.g. PSPDN) referred to as “access unit (AU)” in the following sections. This connection may be initiated by the user or the AU. From the ISDN point of view, the circuit-switched call control procedures of 5 apply. Only the B-channel is used in this case.

Superseded by a more recent version

b) *Packet switched access to an ISDN virtual circuit service (Case B)*

by establishing a packet-mode access connection to the packet handler (PH) of an ISDN. This connection may be initiated by the user or the ISDN. Both B- and D-channels may be used in this case.

The protocol and the text of 6.1-6.5 and Appendix II, and 6.1-6.5 and Appendix III/X.31, are identical.

The term “user” refers to the user equipment which may consist of an ISDN packet-mode terminal (TE1) or a combination of an existing data terminating equipment (DTE/TE2) attached to a terminal adaptor (TA). A DTE may not receive all of the information provided in Q.931 signalling messages at the user-network interface.

The ISDN TA/TE1 presents an S/T-interface towards the network and therefore the TA/TE1 implementation should embody the procedures described in Recommendation Q.921 and this Recommendation for B- and D-channel connection establishment and control.

For demand access connections, 6.1 through 6.4 apply. Example message flows for demand access connections are shown in Appendix II.

Two physical types of semi-permanent connections on B- and D-channels are covered in this clause:

- 1) physical layer semi-permanently established between the terminal and the PH/AU, i.e. the I.430 and I.431 physical layer remains activated and the physical path through the ISDN is connected semi-permanently; and
- 2) X.25 data link and physical layers semi-permanently established between the terminal and the PH/AU (in this type, both the user and the network shall keep the X.25 data link layer in the established state).

When a PVC is used, there must exist a type 2) semi-permanent connection.

In semi-permanent connection type 1), the procedures of 6.3 are followed for X.25 call establishment and release.

In semi-permanent connection type 2), only the procedures of 6.3.2 are followed for X.25 call establishment and release.

When semi-permanent connection type 2) is used for PVCs, none of the following procedures apply.

Semi-permanent connections are established via a provisioning process without Q.931 procedures.

6.1 **Outgoing access**

If the user selects an already established channel for the outgoing X.25 virtual call, then the procedures described in 6.3 apply. If the selected channel is not established to the AU/PH, then the procedures for activating a channel described in the following subsections are to be used before establishing the virtual call using the procedures of 6.3.

For outgoing X.25 data calls, the user first must decide whether circuit-switched (Case A) or packet-switched services (Case B) are desired from the network. For outgoing circuit calls, the user follows the procedures of 6.1.1. For outgoing packet calls, the user decides whether the B-channel or D-channel is to be used for the packet call. If the user decides to use the B-channel, then the procedures described in 6.1.2.1 are used. If the user decides to use the D-channel, then the procedures described in 6.1.2.2 are used.

NOTE – Some networks may not support every type of access. In the case of B-channel access, the network will clear a request for unsupported services by sending a RELEASE COMPLETE message with cause No. 65, *bearer capability not implemented*. In the case of a request for D-channel access (an SABME with SAPI=16), on a network port which does not support the service, no response is required of the network.

6.1.1 **Circuit-switched access to PSPDN services (Case A)**

The B-channel connection between the user and the AU shall be controlled using the D-channel signalling procedures for call establishment described in 5.1. The specific B-channel to be used as a switched connection is selected using the channel selection procedures described in 5.1.2 and summarized in Table 6-1.

Superseded by a more recent version

TABLE 6-1/Q.931

User requested channel and network response, Outgoing access to either an AU or PH

Channel indicated in the SETUP message user to network direction			Allowable network response (network-user)
Information channel selection	Preferred or exclusive	D-channel indicator (Note 1)	
Bi	Exclusive	No	Bi
	Preferred	No	Bi, Bi'
Any	(Ignore)	No	Bi'
(Absent)			Bi'
Bi The indicated (idle) B-channel Bi' Any (other) idle B-channel NOTES 1 D-channel indicator shall be encoded "0" to indicate No and "1" to indicate Yes. 2 All other encodings are invalid. 3 All columns under the heading "Channel indicated in the SETUP message" indicate possible user codings of the Channel identification information element contained in the SETUP message sent by the user to the network requesting a connection to an AU or PH (see 4.5.13). The column under "Allowable network response" refers to the allowable responses by the network to the user.			

On the basis of the call set-up information (e.g. called party number identifying an AU, transit network selection, etc.) and/or a subscription time agreement, the network provides a connection to the appropriate AU. The Bearer capability information element included in the SETUP message shall be encoded with

- information transfer capability set to either
 - a) *unrestricted digital information*; or
 - b) *restricted digital information*;
- transfer mode set to *circuit mode*;
- information rate set to *64 kbit/s*.

The user may also specify the layer 1 (e.g. rate adaption), layer 2 (i.e. LAPB), and layer 3 (i.e. X.25) information transfer protocols in the Low layer compatibility information element in the SETUP message (see Annex I).

6.1.2 Access to the ISDN virtual circuit service (Case B)

6.1.2.1 B-channel

Demand access B-channel connections are controlled using the D-channel signalling procedures for call establishment described in 5.1 using the messages defined in 3.2 with the following exceptions:

- a) the procedures for overlap sending specified in 5.1.3 do not apply;
- b) the procedures for call proceeding and overlap sending specified in 5.1.5.2 do not apply;
- c) the procedures for notification of interworking at the origination interface specified in 5.1.6 do not apply;
- d) the procedures for call confirmation indication specified in 5.1.7 do not apply;

Superseded by a more recent version

- e) the procedures for call connection specified in 5.1.8 apply as follows:
 - upon accepting the access connection, the network shall send a CONNECT message across the user-network interface to the calling user and enter the Active state;
 - this message indicates to the calling user that an access connection to the packet handler has been established;
 - on receipt of the CONNECT message, the calling user shall stop timer T310, if running, may optionally send a CONNECT ACKNOWLEDGE message, and shall enter the Active state;
- f) the procedures for call rejection specified in 5.1.9 apply as follows:
 - when unable to accept the access connection, the network shall initiate ISDN access connection clearing at the originating user-network interface as described in 5.3;
- g) the procedures for transit network selection specified in 5.1.10 do not apply.

The specific B-channel to be used as a demand connection is selected using the channel selection procedures described in 5.1.2 and summarized in Table 6-1.

For a demand connection to an ISDN PH, the Bearer capability information element included in the SETUP message shall be coded with:

- information transfer capability set to *unrestricted digital information*;
- transfer mode set to *packet mode*;
- information transfer rate set to 00000;
- user information layer 2 protocol set to *Recommendation X.25, link layer*;
- user information layer 3 protocol set to *Recommendation X.25, packet layer*.

NOTE – Octets 5a, 5b, 5c and 5d shall not be included.

The demand access connection can then be used to support packet communications according to X.25 link layer and X.25 packet layer procedures as specified in 6.3.

Some ISDNs may require the Calling party number and the Calling party subaddress information elements to be included in the SETUP message to select a specific user profile.

6.1.2.2 D-channel

The D-channel provides a connection which enables the ISDN user terminal to access a PH function within the ISDN by establishing a link layer connection (SAPI=16) to that function which can then be used to support packet communications according to X.25 layer 3 procedures as defined in 6.3. The X.25 packet layer uses the acknowledged information transfer service (i.e. I-frames) provided by LAPD (see Recommendation Q.920 [45]). Consequently, Q.931 procedures are not required to provide D-channel access.

A number of packet mode user equipment can operate simultaneously over the D-channel, each using a separate ISDN layer 2 data link identified by an appropriate address (see Recommendation Q.921) in frames transferred between the user and the PH.

6.2 Incoming access

6.2.1 Access from PSPDN services (Case A)

The ISDN signals the establishment of the circuit-mode connection using the procedures described in 5.2. The X.25 virtual calls are signalled between the user and the AU using the procedures described in 6.3.

6.2.1.1 General

The general procedures performed by the AU are those defined in Recommendation X.32.

Superseded by a more recent version

6.2.1.2 Channel selection

If the ISDN physical circuit desired by the AU does not exist between the terminal and the AU, the procedures for physical channel establishment described in the following sections apply.

The format of the SETUP message sent by the network to the user is in accordance with 3.1.

The Bearer capability information element included in the SETUP message shall be encoded with:

- information transfer capability set to either
 - a) *unrestricted digital information*; or
 - b) *restricted digital information*;
- transfer mode set to *circuit mode*;
- information rate set to *64 kbit/s*.

The Channel identification information element shall be encoded according to Table 6-2.

The B-channel connection to the called user shall be established by the network using the signalling procedures described in 5.2. The call is offered by sending the SETUP message on a point-to-point data link or on the broadcast data link.

The user responds to the SETUP as defined in 5.

TABLE 6-2/Q.931

**Network requested channel and user response,
Incoming access from an AU**

Channel indicated in the SETUP message network to user direction			Allowable network response (user-network)
Information channel selection	Preferred or exclusive	D-channel indicator (Note 1)	
Bi	Exclusive	No	Bi
Bi	Preferred	No	Bi, Bi' (Note 2)
Bi Indicated (idle) B-channel Bi' Any other idle B-channel (not permitted for broadcast call offering) NOTES 1 D-channel indicator shall be encoded "0" to indicate No and "1" to indicate Yes. 2 This encoding is not used for broadcast call offering. 3 All other encodings are invalid.			

6.2.2 Access from the ISDN virtual circuit service (Case B)

To offer an incoming X.25 call, the network must perform the following steps in sequence:

- 1) *Channel selection* – The physical channel/logical link to be used for the incoming call must be identified. The network may use customer profile information, network resources, etc., to choose the channel or the procedures of Step 2 below.
- 2) *Physical channel/logical link establishment* – If the physical B-channel or the logical link of the D-channel have not been determined by Step 1, the network may use the procedures in 6.2.2.3. The network may then proceed with Step 3.
- 3) *X.25 virtual call establishment* – The network establishes the virtual call using the procedures described in 6.3.

Superseded by a more recent version

In the configuration for the ISDN virtual circuit bearer service, the choice of channel type to be used for the delivery of a new *incoming call* packet shall be made by the network as described below.

- a) A new *incoming call* packet may be indicated to the ISDN customer by a call offering procedure between the network and all user packet-mode terminals (see 3.2.3.2/X.31 and 3.2.3.3/X.31 [14]).
- b) An incoming virtual call directed to a terminal with an established connection to the PH may be offered directly to the terminal over the established access connection without the use of Q.931 call offering procedures (see 3.2.3.1/X.31 and 3.2.3.2/X.31 [14]).

6.2.2.1 B-channel

When X.25 calls are to be offered on the B-channels without channel negotiation, the procedures described in 5.2 using the messages of 3.2 apply with the following exceptions:

- a) The procedures for overlap receiving specified in 5.2.4 do not apply.
- b) The procedures for receipt of CALL PROCEEDING and ALERTING specified in 5.2.5.2 apply with the following exception:
 - The receipt of an ALERTING message shall not cause the network to send a corresponding ALERTING message to the calling user.
- c) The procedures for call failure specified in 5.2.5.3 apply with the following remark:
 - The network clears the incoming X.25 virtual call towards the calling X.25 DTE using the appropriate cause from Table 6-5.
- d) The procedures for notification of interworking at the terminating interface specified in 5.2.6 apply with the following exceptions:
 - The case of the call entering an ISDN environment during call establishment is not applicable.
 - In the case of a call leaving the ISDN environment within the called user's premises, no notification is sent to the calling party.
 - The case of in-band information/patterns is not applicable.
- e) The procedures for active indication specified in 5.2.8 apply with the following exception:
 - The network shall not initiate procedures to send a CONNECT message towards the calling user.
- f) The procedures for user notification specified in 5.9 do not apply.

Where an established B-channel connection is to be used, the *incoming call* packet will be delivered in accordance with 6.3.

Where a new B-channel connection is to be established, the identity of the selected user will be associated with the Connection Endpoint Suffix (CES) from which the first CONNECT message has been received.

6.2.2.2 D-channel

The D-channel provides a connection which enables the ISDN PH to access an ISDN user terminal or vice versa. This access is accomplished by establishing an ISDN link layer connection (SAPI=16) to the terminal or network which can then be used to support packet communications according to X.25 [5] layer 3 procedures as defined in 6.3.

The layer 2 procedures shall be in accordance with Recommendation Q.921 [3]. The D-channel provides a semi-permanent connection for packet access since all D-channel layer 2 frames containing a packet-mode SAPI (16) are routed automatically between the user and the PH function.

When an incoming call is offered to packet-mode user equipment at the user interface, the channel selection procedures described in 6.2.2.3 shall be used.

A number of packet mode terminals can operate simultaneously over the D-channel, each using a separate layer 2 link identified by an appropriate TEI (see Recommendation Q.921) in frames transferred between the terminal and the network.

Superseded by a more recent version

6.2.2.3 Call offering

6.2.2.3.1 Channel selection through call offering

The call offering procedure is performed using the layer 3 messages and procedures of clause 5. The call offering procedure is integrated into the circuit-switched call control procedures, signalled on the D-channel, with the channel selection being accomplished by means of the channel selection procedure if offered as a network option.

As described in clause 5, the network selects the first user which responds to the call offering with a CONNECT message. When the selected user has requested that the X.25 call be set up over a new B-channel, the network will indicate that the channel is acceptable by returning a CONNECT ACKNOWLEDGE message to the user. If multiple terminals have responded positively to the SETUP message, the network shall clear each of the non-selected terminals with a RELEASE message containing cause No. 26, *non-selected user clearing*.

When the selected user has requested that the X.25 call be set up over an established B-channel or the D-channel, the network shall respond to the CONNECT message with a RELEASE message containing cause No. 7, *call awarded and being delivered in an established channel*. The network shall also return a RELEASE message containing cause No. 26, *non-selected user clearing* to any other positively responding terminals. The network will then deliver the X.25 virtual call over the selected channel.

NOTE 1 – There is no time significance between the delivery of the RELEASE message and the incoming call packet, i.e. either may occur first.

NOTE 2 – The network shall send the RELEASE message(s) and the user(s) shall respond with RELEASE COMPLETE.

If the channel indicated by the first positively responding user is not available, the network will use Q.931 call clearing procedures to clear the call with cause No. 6, *channel unacceptable*. If the channel indicated in the SETUP message is not acceptable to the user, the user will clear the call with a RELEASE COMPLETE message containing cause No. 34, *no circuit/channel available* or cause No. 44, *requested circuit/channel not available*.

On the basis of a network option or subscription agreement, the network may choose the access channel or access channel type (e.g. B or D) for a particular incoming packet call.

When the Channel indication information element indicates *Channel indication = No channel, Exclusive, and D-channel indication – Yes*, then the Bearer capability information element should be coded as follows:

- information transfer capability set to *unrestricted digital information*;
- transfer mode set to *packet mode*;
- information rate set to *packet mode (00000)*;
- layer 2 protocol set to *Recommendation Q.921*;
- layer 3 protocol set to *Recommendation X.25, packet layer*.

In all other cases, the Bearer capability information element should be encoded as follows:

- information transfer capability set to either
 - a) *unrestricted digital information*; or
 - b) *restricted digital information*;
- transfer mode set to *packet mode*;
- information rate set to *packet mode (00000)*;
- layer 2 protocol set to *Recommendation X.25, link layer*;
- layer 3 protocol set to *Recommendation X.25, Packet layer*.

There exists an understanding that if the terminal responds with D-channel indication set (see Table 6-3), the Layer 2 protocol to be used is Recommendation Q.921 (LAPD).

Superseded by a more recent version

TABLE 6-3/Q.931

Network requested channel and user response Incoming access for packet-mode

Channel indicated in the SETUP message network to user direction			Allowable network response (network-user)
Information channel selection	Preferred or exclusive	D-channel indicator (Note 1)	
Bi	Exclusive	No	Bi
		Yes	Bi, D
Bi	Preferred	No	Bi, Bi', Bj
		Yes	Bi, Bi', Bj, D
No channel	Preferred	No	Bj
		Yes	BJ, D
	Exclusive	Yes	D

Bi Indicated (idle) B-channel
Bi' Any other idle B-channel (not permitted in response to broadcast call offering)
Bj An established B-channel under the user's control (a semi-permanent B-channel which is allocated to the user may be indicated if the user subscribes to the unconditional notification class)
D The D-channel

NOTES

- D-channel indicator shall be encoded "0" to indicate No and "1" to indicate Yes.
- All other encodings are invalid.

The channel selection procedure for incoming calls is independent of the type of channel selected at the calling end. In this respect, any combination of channel type used at each end is possible, provided the user rates and available bandwidth are compatible.

The channel selection principle to be used in the procedure is shown in Table 6-3.

NOTE 3 – When the incoming SETUP message is sent on a broadcast data link with a Channel identification information element which indicates an idle B-channel and *preferred*, the called user is not permitted to respond with a different idle B-channel in the response. The option to respond with a different idle channel is restricted to point-to-point call offerings.

NOTE 4 – Networks providing packet-mode call offering shall provide Q.931 signalling procedures for packet-mode calls on SAPI=0. For an interim period, some networks, by subscription agreement, may offer SAPI=16 broadcast call offering procedures for providing Q.931 signalling. This option shall use all Q.931 procedures for packet-mode calls with the following restriction: All calls will be offered as *D-channel exclusive* and will not provide channel selection procedures. Terminals implementing SAPI=16 procedures should also implement SAPI=0 procedures for portability.

6.2.2.3.2 Information element mapping

Some networks may choose to provide a service of mapping some or all of the information from the *incoming call* packet into the SETUP message (see 3.2.3/X.31). Table 6-4 shows the mapping of the X.25 incoming call elements to Q.931 information elements. The *incoming call* packet will still contain these fields when it is delivered. See 3.2.3/X.31 for mapping requirements.

6.2.2.3.3 Channel selection without call offering

Where the network and user have agreed beforehand, the network may route an incoming call to the called user over an established B-channel connection or D-channel link without the need for any signalling for channel selection.

Superseded by a more recent version

6.3 X.25 virtual call establishment and release

In all cases, once the physical channel has been selected and, if necessary, connected to the PH or AU, the virtual call is established according to the procedures below. Some networks may require some of the terminal identification procedures of Recommendation X.32 as well.

6.3.1 Link layer establishment and release

Link layer (LAPB on the B-channel or LAPD on the D-channel) establishment shall be initiated by

- the calling terminal in the case of outgoing calls;
- the AU in the case of incoming calls in Case A; or
- the PH in the case of incoming calls in Case B.

Link layer release may be initiated by:

- the terminal;
- the AU in Case A; or
- the PH in Case B.

TABLE 6-4/Q.931

Mapping of X.25 information elements to corresponding Q.931 SETUP message information elements in packet-mode incoming call ^{a)}

	Information elements in X.25 <i>incoming call packet</i>	Corresponding information element in Q.931 SETUP message
	Calling DTE address	Calling party number (Note 6)
	Called DTE address	Called party number
	User data (UD)	User-user information (Note 1)
	A-bit (Note 2)	For further study
	D-bit	Packet layer binary parameters
	Modulus	Packet layer binary parameters
X.25 user facility	Flow control parameter negotiation	Packet size, Packet layer window size
	Throughput class negotiation	Information rate (Note 4)
	Fast select	Packet layer binary parameters
	Reverse charging	Reverse charging indication
	Closed user group selection	Closed user group
	Closed user group with outgoing access selection	Closed user group
	Bilateral closed user group	For further study
	Transit delay selection and indication	Transit delay selection and indication
	Call redirection and deflection notification	Redirecting number
DTE facility	Calling address extension	Calling party subaddress
	Called address extension	Called party subaddress (Note 5)
	End-to-end transit delay	End-to-end transit delay
	Minimum throughput class	Information rate (Note 3)
	Expedited data negotiation	Packet layer binary parameters
	Priority	For further study
	Protection	For further study

Superseded by a more recent version

TABLEAU 6-4/Q.931 (continued)

Mappint of X.25 information elements to corresponding Q.931 SETUP message information elements in packet-mode incoming call ^{a)}

a) Mapping is optional or required as indicated in 3.2.3/X.31.

NOTES

1 The maximum length of the user data within the User-user information element is network dependent and is either 32 or 128 octets.

2 The need and procedures for A-bit mapping is for further study.

3 This information is not always present even when the "Information rate" is provided in the Q.931 SETUP message.

4 When the "Throughput class negotiation" is not set in the X.25 incoming call packet, this information shall be provided as the default throughput values applying to the virtual call.

5 The network will map bits 8 and 7 of the first octet of the called address extension facility parameter field in X.25 incoming call packet to *type of subaddress* field in octet 3 of the Called party subaddress information element in the Q.931 SETUP message, assuming that the X.25 incoming call packet is coded based on the 1988 version of X.25. Therefore, the called user should notice that the received *type of subaddress* may not be correct when the X.25 incoming call packet is coded based on the 1984 version of X.25.

6 This mapping is mandatory and octet 3a shall be set with Presentation indicator set to *presentation allowed* and Screening indicator set to *network period*.

6.3.2 Packet layer virtual call setup and release

The packet layer procedures of Recommendation X.25 will be used for layer 3 call setup and release. The packet layer procedures will additionally be able to control and monitor the established or released state of the link layer.

In Case B, the PH may maintain a timer T320 (defined in this Recommendation). T320, if implemented, is started

- a) upon clearance of the last virtual call; or
- b) upon transmission of a CONNECT message by the network in case of an outgoing B-channel access connection; or
- c) upon transmission of a CONNECT ACKNOWLEDGE message by the network in case of an incoming B-channel access connection; or
- d) upon establishment of the link layer for D-channel access connections.

T320 is cancelled upon:

- 1) establishment of the first (next) virtual call; or
- 2) receipt of a Q.931 clearing message from the user; or
- 3) disconnection of the SAPI=16 link on the D-channel.

Upon expiry of timer T320, the PH will release the link layer and, in the case of B-channel access, initiate clearing of the B-channel.

X.25 logical channels are associated with their underlying logical link. Specifically, in the case of the use of the B-channel for packet communication there is an association between the logical channels and the LAPB logical link below them. Thus, the same logical channel number may be used simultaneously on each different B-channel.

Superseded by a more recent version

6.4 Call clearing

6.4.1 B-channel access

The clearing of the switched connection shall be effected by using the D-channel signalling procedures for call clearing as specified in 5.3. For access to PSPDN services, no exceptions apply. For the ISDN virtual circuit service, the messages of 3.2 are used, and the following exceptions apply:

- The terms defined in 5.3.1 (Terminology) apply by replacing “circuit-switched ISDN connection” with “demand packet mode access connection”.
- The exception condition f) specified in 5.3.2 does not apply.
- The procedures for clearing with tones and announcements provided in 5.3.4.1 do not apply.

The B-channel may be cleared at any time by the user though, in general, it will be cleared following the clearing of the last virtual call over that B-channel. In the ISDN virtual circuit service, if the user clears the B-channel access connection using a Q.931 clearing message while X.25 virtual calls still exist on the B-channel, the network shall clear the X.25 virtual call(s) with cause No. 17, *remote procedure error*, and diagnostic No. 64, *call set-up, call clearing, or registration problem*.

In Case B, if a Q.931 RESTART message is received by the PH during the X.25 data transfer phase, the X.25 virtual calls shall be treated as follows:

- For switched virtual circuits, an X.25 *clear indication* packet shall be sent with cause No. 9, *out of order* and diagnostic No. 0, *no additional information*.
- For permanent virtual circuits, an X.25 *reset* packet shall be sent containing cause No. 9, *out of order* and diagnostic No. 0, *no additional information*.

At the expiration of timer T320, the network may disconnect the X.25 link layer and the access connection. B-channel clearing is as described in 5.3 with the exceptions above, with cause No. 102, *recovery on timer expiry*.

6.4.2 D-channel access

D-channel access connections are cleared using the disconnect procedures as defined in 6.3.

6.4.3 Additional error handling information

When an ISDN access connection failure occurs, or the X.25 virtual call is cleared prematurely, the rules of 5.8 shall apply. In addition, the following rules for determining the appropriate cause to be used shall apply in order of decreasing priority:

- 1) If a Q.931 clearing message or RESTART message is received by the PH during the X.25 data transfer phase, 6.4.1 applies.
- 2) In general, if an ISDN access connection is rejected by the destination user using Q.931 messages, the X.25 virtual call shall be cleared using a *clear indication* packet and cause No. 0, *DTE originated* with diagnostic No. 0, *no additional information*. Some networks may map some Q.931 causes to the corresponding X.25 causes according to Table 6-5.
- 3) If a condition exists that prevents the Q.931 SETUP message from being delivered at the user-network interface, the X.25 virtual call shall be cleared using a *clear indication* packet and a cause shall be selected appropriate to the condition. Table 6-5 shall serve as a guide to selecting an appropriate cause, i.e. the X.25 mapping of the Q.931 cause describing the interface condition shall be used.
- 4) If the Q.931 SETUP message is sent across the user-network interface, but no response is received prior to the second expiry of timer T303, rule No. 3 applies.
- 5) If the Q.931 SETUP message is sent across the user-network interface, and a response other than a call rejection is received from a user which results in the clearing of the ISDN access connection at the user-network interface, the X.25 virtual call shall be cleared using a *clear indication* packet containing cause No. 17, *remote procedure error* with diagnostic No. 64, *call setup, call clearing or registration problem*.

Superseded by a more recent version

- 6) If an X.25 *clear request* packet is received from the originating user prior to the delivery of the X.25 *incoming call* packet to the called user (premature clearing), the PH shall send a *clear confirmation* packet to the calling user and the access connection shall be treated as follows:
- If the Q.931 SETUP message was associated with the Unconditional notification class of service (see 3.2.3/X.31), the access connection, when and if established, shall be cleared. The Q.931 clearing message shall contain the appropriate cause as described in Table 6-6.
 - If the Q.931 SETUP message was associated with the Conditional notification class of service (see 3.2.3/X.31) and there exists at least one terminal which responds positively to the Q.931 SETUP message, then two options are allowed:
 - a) the access connection is cleared as described for the Unconditional class of service; or
 - b) the access connection is established and timer T320 is started. Upon expiry of timer T320, the access connection is cleared with cause No. 102, *recovery on timer expiry* and diagnostic indicating timer T320.

6.4.4 Cause mappings

6.4.4.1 Access to/from PSPDN services (Case A)

The AU may choose to follow the procedures in 6.4.4.2 when mapping between causes delivered by the ISDN or the PSPDN.

6.4.4.2 Access to/from the ISDN virtual circuit service (Case B)

There are several cases where it is necessary to map causes between this Recommendation and Recommendation X.25. ISDN networks shall use Table 6-5 and Table 6-6 to map the causes between Q.931 and X.25 messages. The figures in Appendix II describe some example situations.

TABLE 6-5/Q.931

Mapping of Q.931 cause fields to X.25 cause field

Item	Q.931 cause	Code	Q.931 diagnostic	X.25 cause	Code	X.25 diagnostic	Code
1	Unallocated (unassigned) number	1	Condition: unknown, transient, permanent	Not obtainable	13	Invalid called address	67
2	No route to destination	3	Condition: unknown, transient, permanent	Not obtainable	13	Invalid called address	67
3	Channel unacceptable	6	(None)	Remote procedure error	17	Call set-up, call clearing or registration problem	64
4	Normal call clearing	16	Condition: unknown, transient, permanent	DTE originated	0	No additional information	0
5	User busy	17	(None)	Number busy	1	No logical channel available	71
6	No user responding	18	(None)	Remote procedure error	17	Call set-up, call clearing or registration problem	64

Superseded by a more recent version

TABLE 6-5/Q.931 (continued)

Mapping of Q.931 cause fields to X.25 cause field

Item	Q.931 cause	Code	Q.931 diagnostic	X.25 cause	Code	X.25 diagnostic	Code
7	User alerting, no answer	19	(None)	Remote procedure error	17	Call set-up, call clearing or registration problem	64
8	Call rejected	21	Condition: unknown, transient, permanent + user applied diagnostics	DTE originated	0	No additional information	0
9	Number changed	22	New destination address	Not obtainable	13	Invalid called address	67
10	Destination out of order	27	(None)	Out of order	9	No additional information	0
11	Invalid number format (incomplete number)	28	(None)	Local procedure error	19	Invalid called address	67
12	Normal, unspecified	31	(None)	DTE originated	0	No additional information	0
13	No circuit/channel available	34	(None)	Number busy	1	No logical channel available	71
14	Network out of order	38	(None)	Out of order	9	No additional information	0
15	Temporary failure	41	(None)	Out of order	9	No additional information	0
16	Switching equipment congestion	42	Network identity	Network congestion	5	No additional information	0
17	Requested circuit/channel available	44	(None)	Number busy	1	No logical channel available	71
18	Resources unavailable, unspecified	47	(None)	Network congestion	5	No additional information	0
19	Quality of service unavailable	49	Condition: unknown, transient, permanent	Network congestion	5	No additional information	0
20	Bearer capability not authorized	57	Attribute number	Incompatible destination	33	No additional information	0
21	Bearer capability not presently available	58	Attribute number	Remote procedure error	17	Call set-up, call clearing or registration problem	64
22m	Service or option not available, unspecified	63	(None)	Remote procedure error	17	Call set-up, call clearing or registration problem	64

Superseded by a more recent version

TABLE 6-5/Q.931 (continued)

Mapping of Q.931 cause fields to X.25 cause field

Item	Q.931 cause	Code	Q.931 diagnostic	X.25 cause	Code	X.25 diagnostic	Code
23	Bearer service not implemented	65	Attribute numbers	Incompatible destination	33	No additional information	0
24	Channel type not implemented	66	Channel type	Remote procedure error	17	Call set-up, call clearing or registration problem	64
25	Service or option not implemented, unspecified	79	(None)	Remote procedure error		Call set-up, call clearing or registration problem	64
26	Valid call reference value	81	(None)	Remote procedure error	17	Call set-up, call clearing or registration problem	64
27	Identified channel does not exist	82	Channel identity	Remote procedure error	17	Call set-up, call clearing or registration problem	64
28	Incompatible destination	88	Incompatible parameter	Incompatible destination	33	No additional information	0
29	Invalid message, unspecified	95	(None)	Remote procedure error	17	Call set-up, call clearing or registration problem	64
30	Mandatory information element is missing	96	Information element identifier(s)	Remote procedure error	17	Call set-up, call clearing or registration problem	64
31	Message type non-existent or not implemented	97	Message type	Remote procedure error	17	Call set-up, call clearing or registration problem	64
32	Message not compatible with call state or message type non-existent or not implemented	98	Message type	Remote procedure error	17	Call set-up, call clearing or registration problem	64
33	Information element non-existent or not implemented	99	Information element identifier(s)	Remote procedure error	17	Call set-up, call clearing or registration problem	64

Superseded by a more recent version

TABLE 6-5/Q.931 (end)

Mapping of Q.931 cause fields to X.25 cause field

Item	Q.931 cause	Code	Q.931 diagnostic	X.25 cause	Code	X.25 diagnostic	Code
34	Invalid information element contents	100	Information element identifier(s)	Remote procedure error	17	Call set-up, call clearing or registration problem	64
35	Message not compatible with call state	101	Message type	Remote procedure error	17	Call set-up, call clearing or registration problem	64
36	Recovery on timer expiry	102	Timer number	Remote procedure error	17	Call set-up, call clearing or registration problem	64
37	Protocol error, unspecified	111	(None)	Remote procedure error	17	Call set-up, call clearing or registration problem	64
38	Interworking, unspecified	127	(None)	Remote procedure error	17	Call set-up, call clearing or registration problem	64

NOTES

- 1 When clearing occurs during the X.25 data transfer phase, the procedure described in 6.4.1 should be used.
- 2 When a Q.931 RESTART message is received during the X.25 data transfer phase, switched virtual circuits shall be cleared with a *clear indication* packet containing cause No. 9, *Out of order*, with diagnostic No. 0, *no additional information*. Permanent virtual circuits shall have an X.25 *reset* packet sent with the same cause and diagnostic.

6.5 Access collision

When the network offers a packet-mode call at the interface simultaneously with the user requesting a packet-mode call, the network shall give priority to the completion of the incoming call. If the user determines that accepting the incoming call would meet the needs of its own outgoing call request, the user may clear the call request and accept the incoming call.

7 User signalling bearer service call control procedures

7.1 General characteristics

This feature allows the users to communicate by means of user-to-user signalling without setting up a circuit-switched connection. A temporary signalling connection is established and cleared in a manner similar to the control of a circuit-switched connection.

Superseded by a more recent version

TABLE 6-6/Q.931

Mapping of X.25 cause to Q.931 cause for premature clearing of the incoming call

Item	X.25 cause in clear indication packet				Q.931 error condition		
	X.25/X.96 cause	Code	Diagnostic	Code	Q.931 cause	Code	Diagnostic
1	DTE originated	0	No additional information	0	Normal call clearing	16	(None)
		1XX	DTE specified	XX			
2	Network congestion	5	No additional information	0	Switching equipment congestion	42	(None)
3	Out of order	9	No additional information	0	Destination out of order	27	(None)
4	Remote procedure error	17	(Any allowed)		Protocol error, unspecified	111	(None)

NOTE – Instead of providing the above mapping of X.25 to Q.931, the PH, as a network option, may code the Q.931 Cause information element to indicate *CCITT Coding Standard* in octet 3, X.25 in octet 3a, and code octets 4 and 5 according to Recommendation X.25, copying the cause from the X.25 *clear indication* packet rather than mapping it to a Q.931 cause.

7.2 Call establishment

Procedures for call establishment are as described in 5.1 and 5.2 with the following modifications.

On call request, the calling user sends a SETUP message identifying, within the Bearer capability and Channel identification information elements, a temporary signalling connection to be established on SAPI = 0. The SETUP message is encoded to indicate:

- i) *Bearer capability information element*
 - Unrestricted digital information in the information transfer capability field;
 - Packet mode in the transfer mode field;
 - User information layer 2 protocol is Recommendation Q.921 and user information layer 3 protocol is this Recommendation in the layer and protocol identification field.
- ii) *Channel identification information element*
 - Exclusive in the preferred/exclusive field;
 - D-channel in the D-channel indicator field;
 - No channel in the channel selection field.

If the network determines that the requested temporary signalling connection service is not authorized or is not available, the network shall initiate call clearing in accordance with 5.3.2 a) or 5.3.2 c) with one of the following causes:

- a) No. 57 – *Bearer capability not authorized;*
- b) No. 58 – *Bearer capability not presently available;*
- c) No. 63 – *Service or option not available, unspecified;* or
- d) No. 65 – *Bearer service not implemented.*

The called user accepts the temporary signalling connection request by sending a CONNECT message towards the calling user. After the called user has received a CONNECT ACKNOWLEDGE message, it may begin sending USER INFORMATION messages. Once the calling user receives a CONNECT message, it can begin sending USER INFORMATION messages.

Superseded by a more recent version

7.3 Transfer of USER INFORMATION messages

Once a temporary signalling connection is established, both users can transfer information between themselves by transferring USER INFORMATION messages across the user-network interface. The network provides for the transfer of such messages from the called to the calling side and vice versa.

The USER INFORMATION message includes the Call reference, the Protocol discriminator, and the User-to-user information elements as defined in 3.3.13. The More data information element may also be sent by the source user to indicate to the remote user that another USER INFORMATION message will follow, containing information belonging to the same block. The use of the More data information element is not supervised by the network.

7.4 Congestion control of USER INFORMATION messages

The network or user will flow-control, when needed, the transfer of USER INFORMATION messages from a user or network by means of a CONGESTION CONTROL message containing a congestion level information element. Two indications of congestion level are specified: "receive not ready" and "receive ready". On receipt of the former, the user or network should suspend sending USER INFORMATION messages; on receipt of the latter, sending may recommence. After having sent a "receive not ready" indication, the network or user shall discard USER INFORMATION messages which are subsequently received. The network or user will send a CONGESTION CONTROL message with a "receive not ready" indication whenever a USER INFORMATION message is locally discarded, if it is possible. The CONGESTION CONTROL message shall also include a cause No. 43 "*access information discarded*".

The receipt of the "receive ready" indication shall be interpreted as an indication that no more than n USER INFORMATION messages may be sent before another receive ready indication is received.

In each direction a Burst Capability of sending n messages is immediately available where n initially equals the value of the Burst parameter x . The value of n shall be decremented by one for every message sent by the user and incremented by y at regular intervals of T ($T = 10$ seconds) subject to the limitation that n may not exceed x , i.e. $n + y \leq x$.

The Burst parameter x is a variable which shall be set to a value of $x = 16$.

The replenishment parameter y shall be capable of taking a value $y = 8$.

NOTE – While some networks may support higher values of x and y , the value of x and y across international interfaces shall be set as above. It is up to the network using higher values to take the appropriate actions, unless bilateral agreements exist.

If USER INFORMATION messages are received at a rate which exceeds the flow control limit set by the network, the network shall discard the messages that cannot be handled and respond to the first discarded message with a control indication. The network shall also respond to the first USER INFORMATION message received following the removal of flow control restriction by returning an indication that further messages may be sent.

The Congestion control procedure should be regarded as local. Congestion control procedure for remote applications is for further study.

7.5 Call clearing

The clearing of an established temporary signalling connection can be initiated by the user or network by sending a RELEASE message towards the far end user. The clearing procedure followed and the timers involved are the same as those for clearing a circuit-switched connection as described in 5.3.3 and 5.3.4.

8 Circuit-mode multirate (64 kbit/s base rate) procedures

This clause provides the D-channel signalling procedures in support of circuit-mode multirate (64 kbit/s base rate) bearer capability.

These procedures are mandatory when a supported bearer capability or teleservice requires a multirate (64 kbit/s base rate) bearer capability, else they are not required.

The procedures of clause 5 shall apply except as identified in the following subclauses.

Superseded by a more recent version

8.1 Call establishment at the originating interface

8.1.1 Compatibility information

The Bearer capability information element shall be encoded as in 4.5.5 (Bearer capability) with the following exceptions:

- 1) Octet 3 shall be coded *unrestricted digital information*.
- 2) Octet 4 shall be coded *circuit-mode* and the information transfer rate (bits 5 to 1) shall be encoded:

Bits					
5	4	3	2	1	Circuit-mode
1	1	0	0	0	Multirate (64 kbit/s base rare)

- 3) Octet 4.1 (Rate multiplier) shall be included. Bit 8 is for extension and set to 1. Bits 7-1 contain the binary coding of the multiplier that applies to the multirate codepoint contained in the information transfer rate subfield. Bit 1 is least significant. The multiplier value range is 2-30, all other values are reserved. Octet 4.1 shall be included if and only if the transfer rate is coded for multirate.

NOTE – When the information transfer rate is 384 kbit/s, 1536 kbit/s, or 1920 kbit/s the information transfer rate in the Bearer capability information element may also be coded as 384 kbit/s (10011), 1536 kbit/s (10101), or 1920 kbit/s (10111) respectively instead of using the multirate (64 kbit/s base rate) codepoint and the associated rate multiplier field.

8.1.2 Channel selection

The channels selected for the multirate call shall be on one interface and shall be indicated in the SETUP message. The procedures in 5.1.2 and 5.2.3.1 shall be followed to complete the channel selection.

The Channel identification information element is coded as per 4.5.13.

The number of channels identified shall provide the information transfer rate identified in the Bearer capability information element. If the information transfer rate implied by the channel(s) or interface indicated in the Channel identification information element does not match the information transfer rate in the Bearer capability information element the procedures in 5.8.6.2 shall apply.

Channel selection conflict occurs when the channels selected for an incoming and outgoing call do not constitute two disjoint sets of time slots. When channel selection conflict occurs, the procedures in 5.7 shall apply.

Some networks may offer on access:

- 1) contiguous channel assignment (channels must be adjacent within a single interface); and/or
NOTE 1 – On a 2048 kbit/s interface (containing a D-channel) channels 15 and 17 shall be considered contiguous.
- 2) non-contiguous channel assignment (channels may be either adjacent or non-adjacent within a single interface),

Some networks may require that 384 kbit/s and/or 1536 kbit/s (in a 2048 kbit/s interface) occupy specified contiguous time slots (see Annex A/I.431).

If the entire interface of a primary rate interface is used (i.e. 24 B-channels on a 1544 kbit/s interface or 30 B-channels on a 2048 kbit/s interface) octets 3.2 and 3.3 of the Channel identification information element shall not be included.

If the entire interface of a basic access interface is used (i.e. 2 B-channels) octets 3.2 and 3.3 of the Channel identification information element shall not be included and the “information channel selection” shall be coded “11”, *any channel*.

In cases a) and b) of 5.1.2, if all the indicated B-channels are available, the network shall select them for the call.

Superseded by a more recent version

In case b), if the network cannot grant any referred B-channel, it shall select any other available B-channels associated with the D-channel and on the same access, to replace the unavailable preferred B-channel, or select all the B-channels on another interface controlled by the D-channel.

NOTE 2 – Whether only the B-channels that cannot be provided should be changed, or if all the B-channels can then be changed is for further study.

In case c), the network shall select any available suitable B-channels.

In case a), if any specified B-channel is not available, and in cases b) and c) if insufficient B-channels are available, the network shall send a RELEASE COMPLETE message with cause No. 44, *requested circuit/channel not available* or No. 34, *no circuit/channel available*, respectively, as described in 5.3.

The following recommendations are made on the use of cause values.

- 1) When the calling user or called user is not an authorized subscriber of the multirate circuit-mode bearer capability, cause No. 57 *bearer capability not authorized* shall be returned to the calling user.
- 2) When a network (public or private) cannot support the specified transfer rate or bearer capability, cause No. 65 *bearer capability not implemented* shall be returned to the calling user.
- 3) When there are insufficient channels on a single interface to support the information transfer rate requested, cause No. 34 *no circuit/channel available* or cause No. 17 *user busy* shall be returned to the calling user (see Recommendation Q.850 which is also reproduced in Appendix I).

8.1.3 Interworking

Interworking is possible between:

- 1) A user who has subscribed to the multirate circuit-mode bearer capability and a user who has subscribed to the 64 kbit/s unrestricted circuit-mode service when the information transfer rate is 64 kbit/s.
- 2) A user who has subscribed to the multirate circuit-mode bearer capability and a user who has subscribed to the 384 kbit/s unrestricted circuit-mode service when the information transfer rate is 384 kbit/s.
- 3) A user who has subscribed to the multirate circuit-mode bearer capability and a user who has subscribed to the 1536 kbit/s unrestricted circuit-mode service when the information transfer rate is 1536 kbit/s.
- 4) A user who has subscribed to the multirate circuit-mode bearer capability and a user who has subscribed to the 1920 kbit/s unrestricted circuit-mode service when the information transfer rate is 1920 kbit/s.

When any other information transfer rate is specified, interworking is not possible between the multirate circuit-mode bearer capability and other services.

8.2 Call establishment at the destination interface

8.2.1 Compatibility information

The Bearer capability information element shall be encoded as in 4.5.5 (Bearer capability) with the following exceptions:

- 1) Octet 3 shall be coded *unrestricted digital information*.
- 2) Octet 4 shall be coded *circuit-mode* and the information transfer rate (bits 5 to 1) shall be encoded:

Bits					
5	4	3	2	1	Circuit-mode
1	1	0	0	0	Multirate (64 kbit/s base rare)

Superseded by a more recent version

- 3) Octet 4.1 (Rate multiplier) shall be included. Bit 8 is for extension and set to 1. Bits 7-1 contain the binary coding of the multiplier that applies to the multirate codepoint contained in the information transfer rate subfield. Bit 1 is least significant. The multiplier value range is 2-30, all other values are reserved. Octet 4.1 shall be included if and only if the transfer rate is coded for multirate.

NOTE – When the information transfer rate is 384 kbit/s, 1536 kbit/s, or 1920 kbit/s the information transfer rate in the Bearer capability information element may also be coded as 384 kbit/s (10011), 1536 kbit/s (10101), or 1920 kbit/s (10111) respectively instead of using the multirate (64 kbit/s base rate) codepoint and the associated rate multiplier field.

8.2.2 Channel selection

The channels selected for the multirate call shall be on one interface and shall be indicated in the SETUP message. The procedures in 5.1.2 and 5.2.3.1 shall be followed to complete the channel selection.

The Channel identification information element is coded as per 4.5.13.

The number of channels identified shall provide the information transfer rate identified in the Bearer capability information element. If the information transfer rate implied by the channel(s) or interface indicated in the Channel identification information element does not match the information transfer rate in the Bearer capability information element the procedures in 5.8.6.2 shall apply.

Channel selection conflict occurs when the channels selected for an incoming and outgoing call do not constitute two disjoint sets of time slots. When channel selection conflict occurs, the procedures in 5.7 shall apply.

Some networks may offer on access:

- 1) contiguous channel assignment (channels must be adjacent within a single interface); and/or
NOTE – On a 2048 kbit/s interface (containing a D-channel) channels 15 and 17 shall be considered contiguous.
- 2) non-contiguous channel assignment (channels may be either adjacent or non-adjacent within a single interface),

Some networks may require that 384 kbit/s and/or 1536 kbit/s (in a 2048 kbit/s interface) occupy specified contiguous time slots (see Annex A/I.431).

If the entire interface of a primary rate interface is used (i.e. 24 B-channels on a 1544 kbit/s interface or 30 B-channels on a 2048 kbit/s interface) octets 3.2 and 3.3 of the Channel identification information element shall not be included.

If the entire interface of a basic access interface is used (i.e. 2 B-channels) octets 3.2 and 3.3 of the Channel identification information element shall not be included and the “information channel selection” shall be coded “11”, *any channel*.

The following recommendations are made on the use of cause values.

- 1) When a network (public or private) cannot support the specified transfer rate or bearer capability, cause No. 65 *bearer capability not implemented* shall be returned to the calling user.
- 2) When the calling user attempts to setup call to a user who has not subscribed to the multirate service the network will initiate call clearing and return cause No. 57 *bearer capability not authorized* to the calling user.
- 3) When there are insufficient channels on a single interface to support the information transfer rate requested, cause No. 34 *no circuit/channel available* or cause No. 17 *user busy* shall be returned to the calling user.

8.2.2.1 Point-to-point configuration

In cases 1) and 2) of 5.2.3.1 if all the indicated traffic channels are available, the user shall select them for the call.

In case 2), if the user cannot grant any referred access channel, it shall select any other available access channels associated with the D-channel and on the same access, to replace the unavailable preferred access channel, or select all the channels on another interface controlled by the D-channel.

NOTE – Whether only the B-channels that cannot be provided should be changed, or if all the channels can then be changed is for further study.

Superseded by a more recent version

In case 3), the user shall select any available suitable access channels.

In case 1), if any specified access channel is not available, and in cases 2) and 3) if insufficient access channels are available, the user shall send a RELEASE COMPLETE message with cause No. 44, *requested circuit/channel not available* or No. 34 *no circuit/channel available*, respectively, as described in 5.3.

8.2.2.2 Point-to-multipoint configuration

In case 1) of 5.2.3.2, if all the indicated traffic channels are available, the user shall select them for the call.

8.2.3 Interworking

Interworking is possible between:

- 1) A user who has subscribed to the multirate circuit-mode bearer capability and a user who has subscribed to the 64 kbit/s unrestricted circuit-mode service when the information transfer rate is 64 kbit/s.
- 2) A user who has subscribed to the multirate circuit-mode bearer capability and a user who has subscribed to the 384 kbit/s unrestricted circuit-mode service when the information transfer rate is 384 kbit/s.
- 3) A user who has subscribed to the multirate circuit-mode bearer capability and a user who has subscribed to the 1536 kbit/s unrestricted circuit-mode service when the information transfer rate is 1536 kbit/s.
- 4) A user who has subscribed to the multirate circuit-mode bearer capability and a user who has subscribed to the 1920 kbit/s unrestricted circuit-mode service when the information transfer rate is 1920 kbit/s.

When any other information transfer rate is specified, interworking is not possible between the multirate circuit-mode bearer capability and other services.

8.3 Call clearing

When the call is cleared, by the user or by the network, all channels associated with the call shall be cleared.

8.4 Restart procedures

B-channels can be restarted irrespective of their usage within a multirate bearer capability. If a single B-channel is restarted, the Q.931 entity shall clear the call.

8.5 Call rearrangements

The procedures of 5.6 do not apply.

9 List of system parameters

The description of timers in the following tables should be considered a brief summary. The precise details are found in clauses 5 and 6, which should be considered the definitive descriptions.

9.1 Timers in the network side

The timers specified in Table 9-1 are maintained in the network side of the interface.

9.2 Timers in the user side

The timers specified in Table 9-2 are maintained in the user side of the interface. Timers T305, T308 and T313 are mandatory for all user side implementations.

Superseded by a more recent version

TABLE 9-1/Q.931

Timers in the network side

Timer number	Default time-out value	State of call	Cause for start	Normal stop	At the first expiry	At the second expiry	Cross-reference
T301	Minimum 3 min	Call received	ALERT received	CONNECT received	Clear call	Timer is not restarted	(Note 2)
T302	10-15 s (Note 5)	Overlap sending	SETUP ACK sent Receipt of INFO, restarts T302	With sending complete indication, or network alert, or connect request received	Clear if call information determined to be definitely incomplete; else send CALL PROC	Timer is not restarted	Mandatory
T303	4 s (Note 1)	Call present	SETUP sent	ALERT, CONNECT CALL PROC or SETUP ACK received, REL COMPLETE received if SETUP sent on point-point data link	Retransmit SETUP; restart T303. If REL COMPLETE has been received, clear the call	Clear network connection. Enter call abort state	Mandatory
T304	20 s (provisional values)	Overlap receiving	SETUP ACK received. Sending of INFO restarts T304	Send INFO; receive CALL PROC, ALERT or CONNECT	Clear the call	Timer is not restarted	Mandatory only if 5.2.4 implemented
T305	30 s	Disconnect indication	DISC without progress indicator No. 8 sent	REL or DISC received	Network sends REL	Timer is not restarted	Mandatory

Superseded by a more recent version

TABLE 9-1/Q.931 (continued)

Timers in the network side

Timer number	Default time-out value	State of call	Cause for start	Normal stop	At the first expiry	At the second expiry	Cross-reference
T306	30 s (Note 6)	Disconnect indication	DISC with progress indicator No. 8 sent	REL or DISC received	Stop the tone/announcement. Send REL	Timer is not restarted	Mandatory when inband tones/announcements are provided; see 5.4, 5.3.4.1, and Rec. I.300-Series
T307	3 min	Null	SUSPEND ACK sent	RES ACK sent	Clear the network connection. Release call identity	Timer is not restarted	Mandatory
T308	4 s (Note 1)	Release request	REL sent	REL COMPLETE or REL received	Retransmit REL and restart T308	Place B-channel in maintenance condition Release call reference (Note 9)	Mandatory
T309	90 s	Any stable state	Data link disconnection. Calls in stable states are not lost	Data link reconnected	Clear network connection. Release B-channel and call reference	Timer is not restarted	Mandatory
T310	10 s (Note 7)	Incoming Call Proceeding	CALL PROC received	ALERT, CONNECT or DISC received. If DISC, retain cause and continue timing	Clear call in accordance with 5.2.5.3	Timer is not restarted	Mandatory

Superseded by a more recent version

TABLE 9-1/Q.931 (continued)

Timers in the network side

Timer number	Default time-out value	State of call	Cause for start	Normal stop	At the first expiry	At the second expiry	Cross-reference
T312	T303 + 2 s	Call Present, Call Abort, etc.	SETUP sent or resent on broadcast data link	Timeout	(Note 4)	Timer is not restarted	Mandatory
T314	4 s	Receiving segmented message	Message segment received	Last message segment received	Discard message	Timer is not restarted	Mandatory see Annex H
T316	2 min	Restart request	RESTART sent	RESTART ACK received	RESTART may be retransmitted several times	RESTART may be retransmitted several times	Mandatory when 5.5 is implemented
T317	(Note 3)	Restart	RESTART received	Internal clearing of call references	Maintenance notification	Timer is not restarted	Mandatory when 5.5 is implemented
T320	30 s (Note 8)	a) For B-channel access: active b) For D-channel access: null	a) For B-channel access: connection b) For D-channel access: DL-ESTABLISHMENT Confirmation or DL-ESTABLISHMENT indication received c) Last logical channel, cleared received	Call request packet received; or incoming call packet delivered; or DISC received; or for D-channel access DL-RELEASE indication received	a) For B-channel access: disconnect link layer and initiate clearing b) For D-channel access: send DL-RELEASE request	Timer is not restarted	Optional. See 6.3

Superseded by a more recent version

TABLE 9-1/Q.931 (end)

Timers in the network side

Timer number	Default time-out value	State of call	Cause for start	Normal stop	At the first expiry	At the second expiry	Cross-reference
T321	30 s	Any call state	D-channel failure	Response to layer 3 message received	Send DL-ESTABLISHMENT request on both D-channels	Timer is not restarted	Mandatory when Annex is implemented
T322	4 s	Any all state	STATUS ENQ sent	STATUS DISC REL or REL COMPLETE received	STATUS ENQ may be retransmitted several times	STATUS ENQ may be retransmitted several times	Mandatory when 5.8.10 is implemented

NOTES

- 1 This default value assumes the use of default values at layer 2 (i.e. N200 + 1] times T200). Whether these values should be modified when layer 2 default values are modified by an automatic negotiation procedure is for further study.
- 2 The network may already have applied an internal alerting supervision timing function; e.g. incorporated within call control. If such a function is known to be operating on the call, then timer T301 is not used.
- 3 The value of this timer is implementation dependent but should be less than the value of T316.
- 4 If in the call abort state, the call reference is released. Otherwise, no action is taken on expiry of timer T312.
- 5 The value of timer T302 may vary beyond these limits, e.g. as a result of called party number analysis.
- 6 The value of timer T306 may depend on the length of the announcement.
- 7 The value of timer T310 may be different in order to take into account the characteristics of a private network.
- 8 This value may vary by network-user agreement.
- 9 The restart procedures contained in 5.5 may be used on B-channels in the maintenance condition.

Superseded by a more recent version

TABLE 9-2/Q.931

Timers in the user side

Timer number	Default time-out value	State of call	Cause for start	Normal stop	At the first expiry	At the second expiry	Cross-reference
T301	Minimum 3 min.	Call Delivered	ALERT received	CONNECT received	Clear call	Timer is not restarted	Mandatory when Annex D is implemented (Note 3)
T302	15 s	Overlap receiving	SETUP ACK sent Restart when INFO received	INFO received with sending complete indication; or internal alerting; or internal connection; or a determination that sufficient information has been received	Clear if call information determined to be incomplete; else send CALL PROC	Timer is not restarted	Mandatory only if 5.2.4 is implemented
T303	4 s (Note 1)	Call Initiated	SETUP sent	ALERT (Annex D), CONNECT (Annex D), SETUP ACK, CALL PROC or REL COMPLETE received	Retransmit SETUP; restart T303. If REL COMPLETE was received, clear the call (Annex D)	Clear internal connection. Send REL COMPLETE. Enter Null state	Mandatory when Annex D is implemented; otherwise optional
T304	30 s	Overlap Sending	INFO sent Restarted when INFO sent again	CALL PROC, ALERT, CONNECT or DISC received	DISC sent	Timer is not restarted	Optional
T305	30 s	Disconnect Request	DISC sent	REL or DISC received	REL sent	Timer is not restarted	Mandatory

Superseded by a more recent version

TABLE 9-2/Q.931 (continued)

Timers in the user side

Timer number	Default time-out value	State of call	Cause for start	Normal stop	At the first expiry	At the second expiry	Cross-reference
T308	4 s (Note 1)	Release request	REL sent	REL COMPLETE or REL received	Retransmit REL; and restart T308.	B-channel is placed in maintenance condition. Call reference released (Note 5)	Mandatory
T309	90 s	Any stable state	Data link disconnection. Calls in stable states are not lost	Data link reconnected	Clear internal connection. Release B-channel and call reference	Timer is not restarted	Optional
T310 (Note 4)	30-120 s	Outgoing Call Proceeding	CALL PROC received	ALERT, CONNECT, DISC, or PROGRESS received	Send DISC	Timer is not restarted	Mandatory when Annex D is implemented
T313	4 s (Note 1)	Connect request	CONNECT sent	CONNECT ACK received	Send DISC	Timer is not restarted	Mandatory
T314	4 s	Receiving Segmented Message	Message segment received	Last message segment received	Discard message	Timer is not restarted	Not initially required
T316	2 min	Restart Request	RESTART sent	RESTART ACK received	RESTART may be retransmitted several times	RESTART may be retransmitted several times	Mandatory when 5.5 is implemented
T317	(Note 2)	Restart	RESTART received	Internal clearing of call reference	Maintenance notification	Timer is not restarted	Mandatory when 5.5 is implemented
T318	4 s	Resume Request	RES sent	RES ACK or RES REJ received	Send RELEASE message with cause No. 102	Timer is not restarted	Mandatory when 5.6 is implemented

Superseded by a more recent version

TABLE 9-2/Q.931 (end)

Timers in the user side

Timer number	Default time-out value	State of call	Cause for start	Normal stop	At the first expiry	At the second expiry	Cross-reference
T319	4 s	Suspend Request	SUSPEND sent	SUSPEND ACK or SUSP REJ received	Enter Active state. Notify user application	Timer is not restarted	Mandatory when 5.6 is implemented
T321	30 s	Any call state	D-channel failure	Response to layer 3 message received	Send DL-ESTABLISHMENT request on both D-channels	Timer is not restarted	Mandatory when Annex F is implemented
T322	4 s	Any call state	STATUS ENQ sent	STATUS, DISC, REL, REL COMPLETE received	STATUS ENQ may be retransmitted several times	STATUS ENQ may be retransmitted several times	Mandatory when 5.8.10 is implemented

NOTES

- 1 This default value assumes the use of default values at layer 2, i.e. $[N200 + 1]$ times T200. Whether these values should be modified when layer 2 default values are modified by an automatic negotiation procedure is for further study.
- 2 The value of this timer is implementation dependent, but should be less than the value of T316.
- 3 The user may already have applied an internal alerting supervision timing function, e.g. incorporated within call control. If such a function is known to be operating on the call, then timer T301 is not used.
- 4 T310 is not started if progress indicator 1 or 2 has been delivered in the CALL PROCEEDING message or in a previous PROGRESS message.
- 5 The restart procedures contained in 5.5 may be used on B-channels in the maintenance conditions.

Superseded by a more recent version

Annex A

User side and network side SDL diagrams

(This annex forms an integral part of this Recommendation)

This annex includes overview and detailed SDL diagrams which show Q.931 protocol control for circuits-switched basic calls. In the event of conflict between these diagrams and the text of clause 5, the text should be the prime source. Similarly, in the event of conflict between overview SDL and detailed SDL diagrams, the detailed SDL diagrams should be the prime source.

Figure A.1 shows key to Q.931 protocol control SDL diagrams for both user side and network side.

Figures A.2 and A.3 show overview and detailed protocol control SDL diagrams for the user side.

Figures A.5 and A.6 show overview and detailed protocol control SDL diagrams for network side. Only procedures for the point-to-point configuration are described in the network side SDL diagrams.

NOTE – Network side SDL diagrams for the point-to-multipoint configuration are left for further study.

Figure A.4 shows detailed SDL diagrams for the global call reference to be applied to both user and network sides. Although Figure A.4 shows SDL diagrams in the user-side only, the same diagrams can be applied to the network side by just changing the direction of input and output symbols.

Superseded by a more recent version

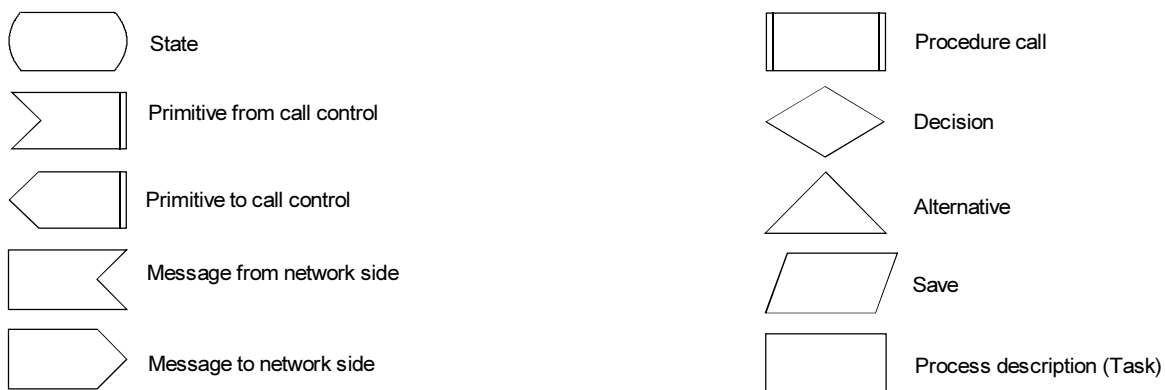
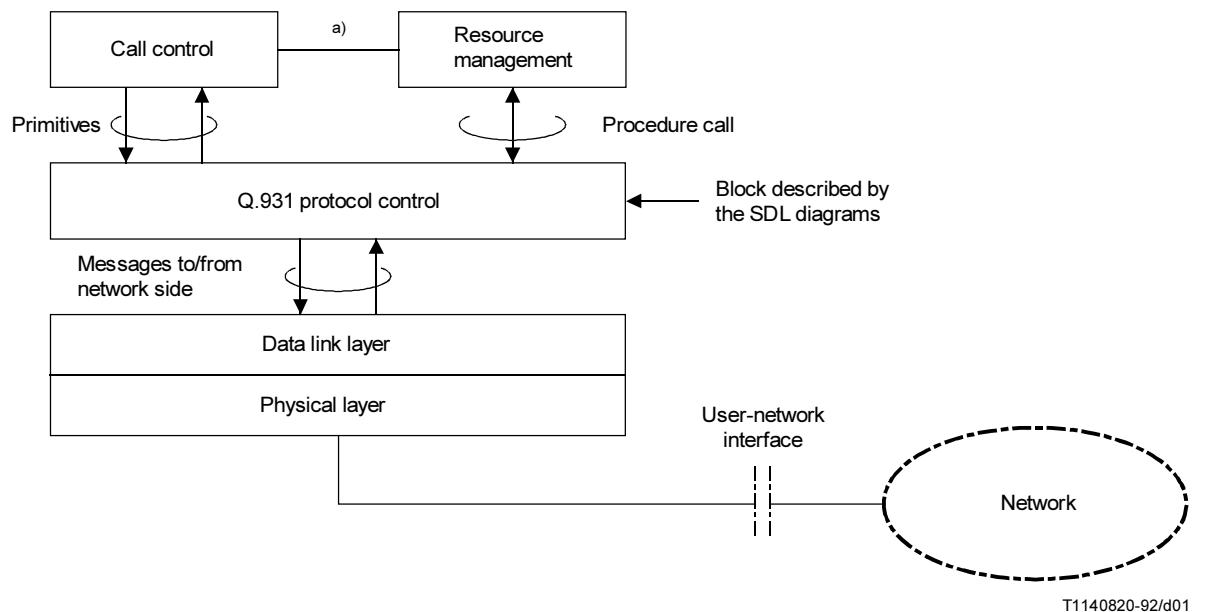

a) Not described in the SDL diagrams.

FIGURE A.1/Q.931 (Sheet 1 of 2)
Key to Q.931 protocol control SDL diagrams (user side)

Superseded by a more recent version

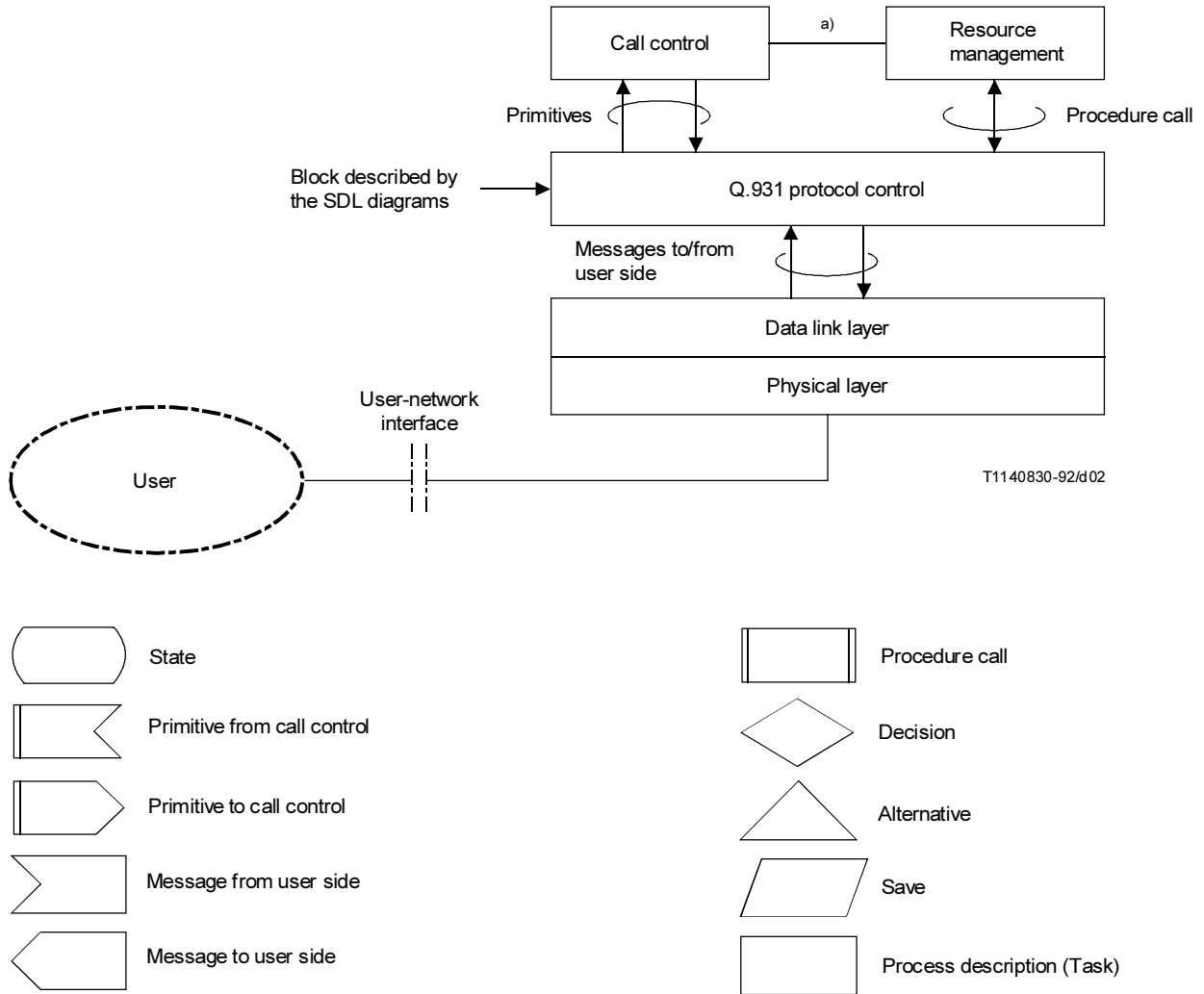

a) Not described in the SDL diagrams.

FIGURE A.1/Q.931 (Sheet 2 of 2)
Key to protocol control SDL diagrams (network side)

Superseded by a more recent version

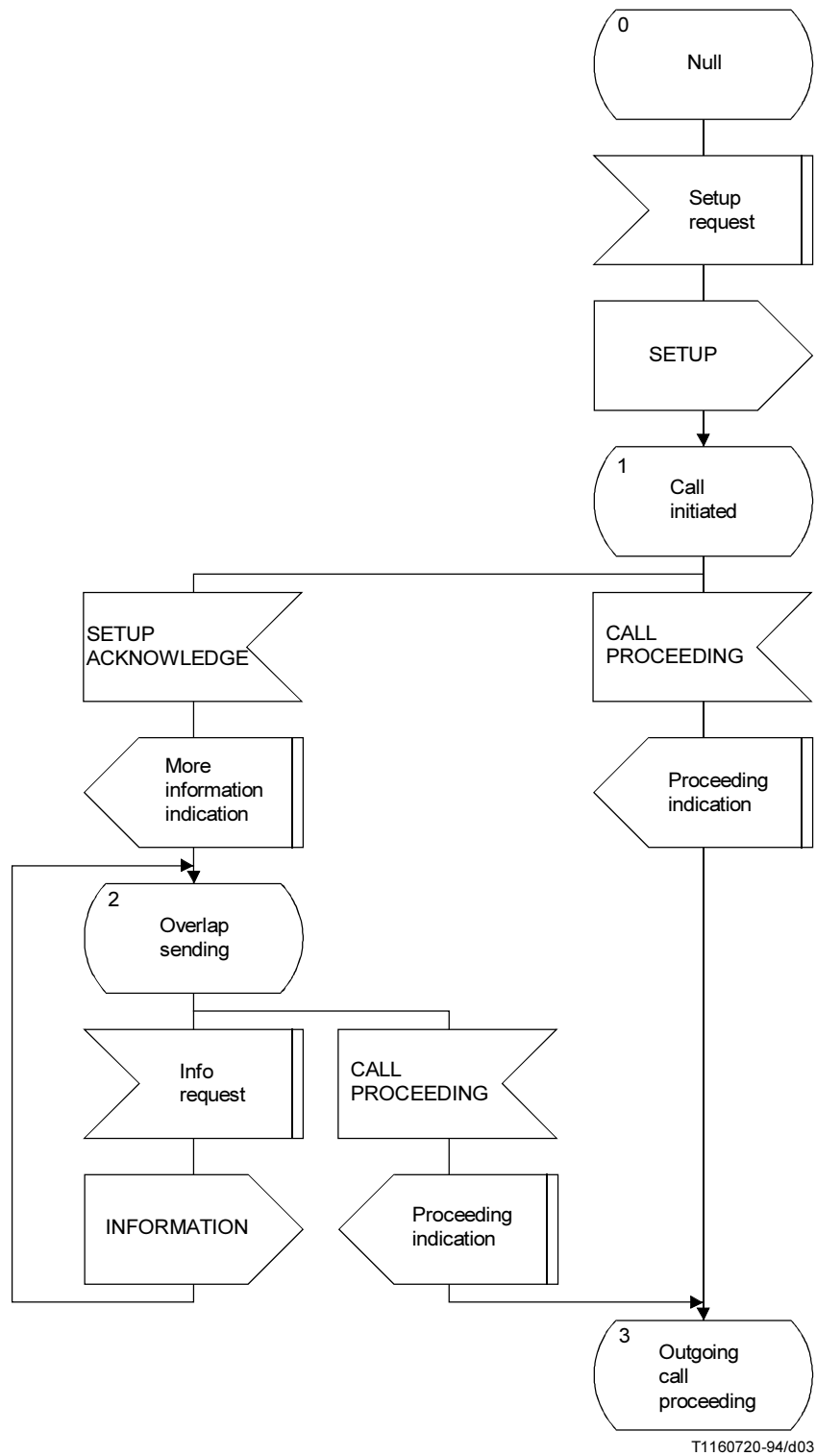

T1160720-94/d03

a) Outgoing set-up procedure (1 of 2)

FIGURE A.2/Q.931 (Sheet 1 of 7)
Overview protocol control (user side)

Superseded by a more recent version

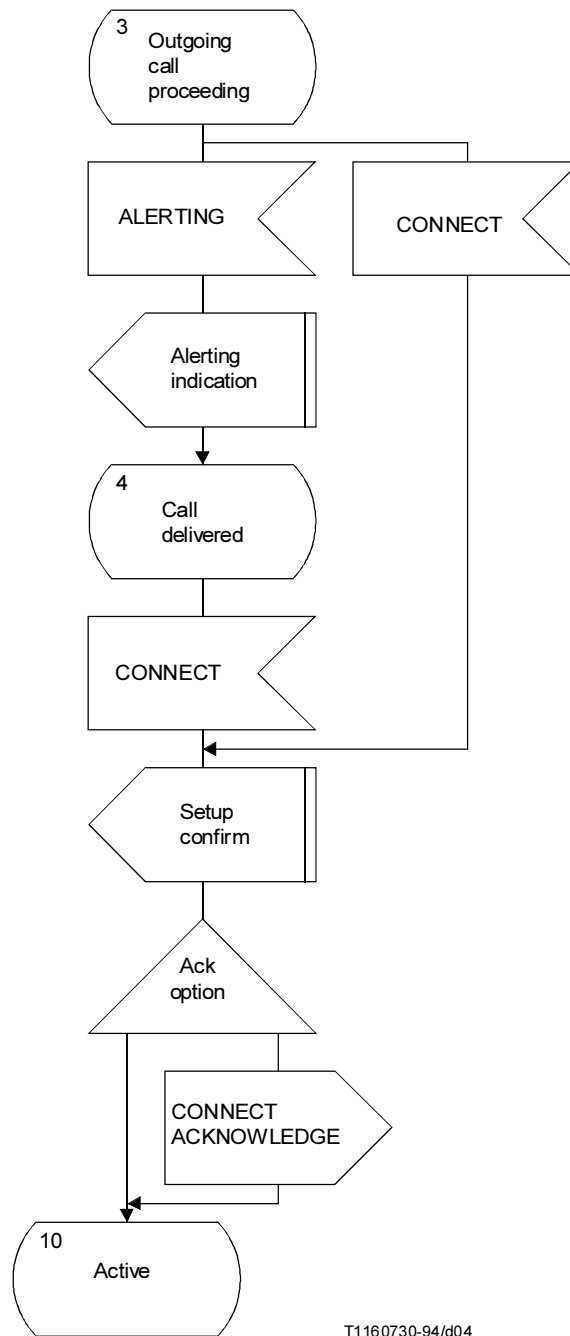

T1160730-94/d04

a) Outgoing set-up procedure (2 of 2)

FIGURE A.2/Q.931 (Sheet 2 of 7)
Overview protocol control (user side)

Superseded by a more recent version

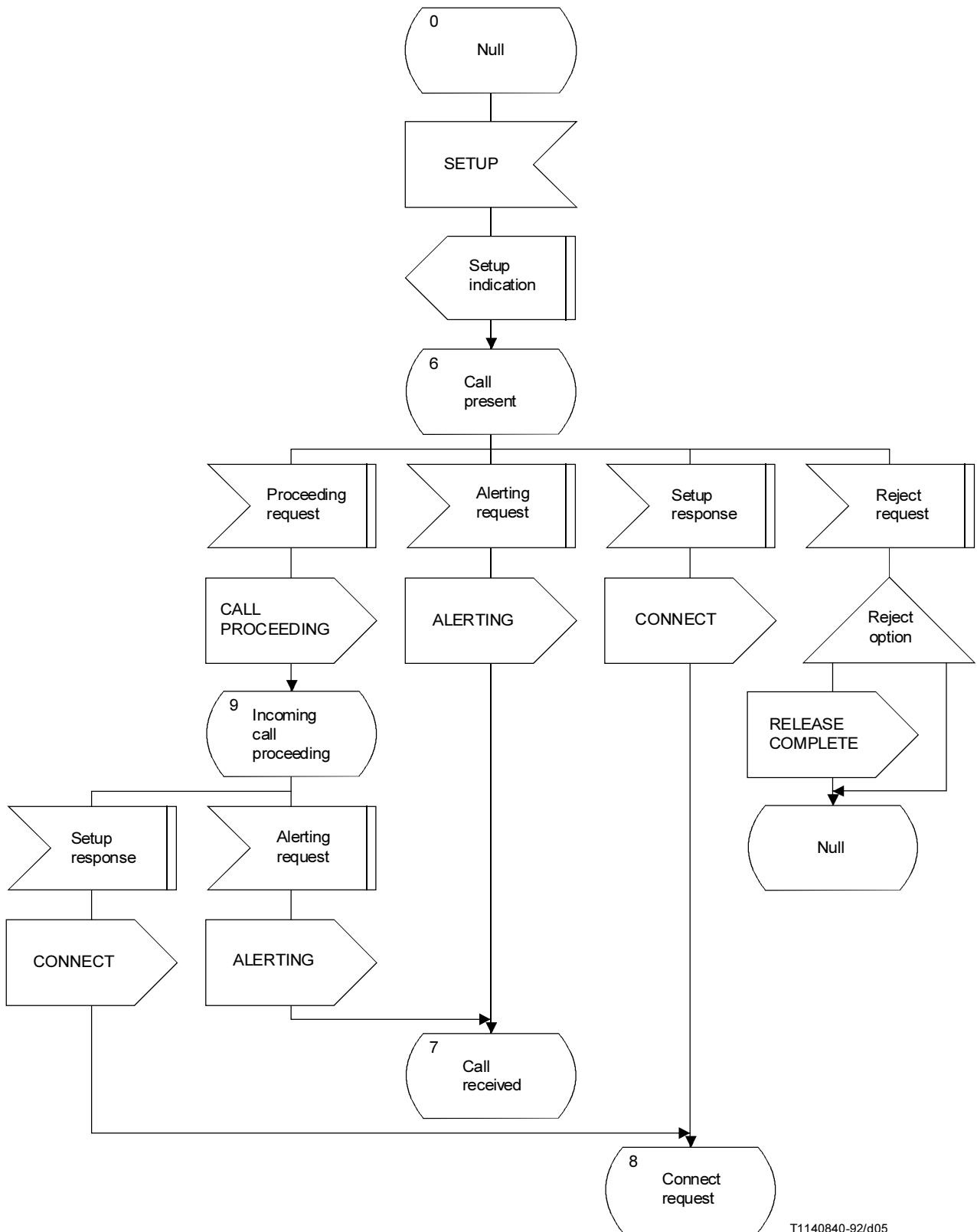

T1140840-92/d05

b) Incoming set-up procedure (1 of 2)

FIGURE A.2/Q.931 (Sheet 3 of 7)
 Overview protocol control (user side)

Superseded by a more recent version

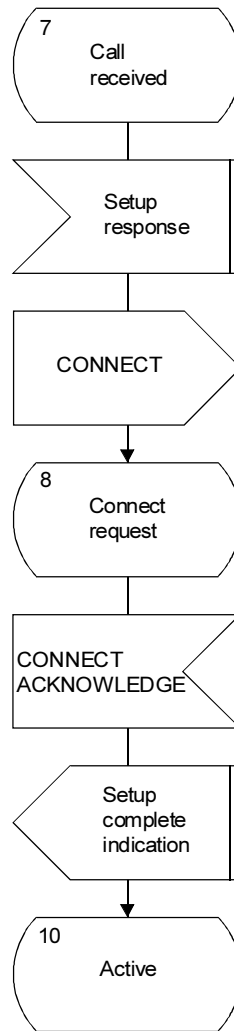

b) Incoming set-up procedure (2 of 2)

FIGURE A.2/Q.931 (Sheet 4 of 7)
Overview protocol control (user side)

Superseded by a more recent version

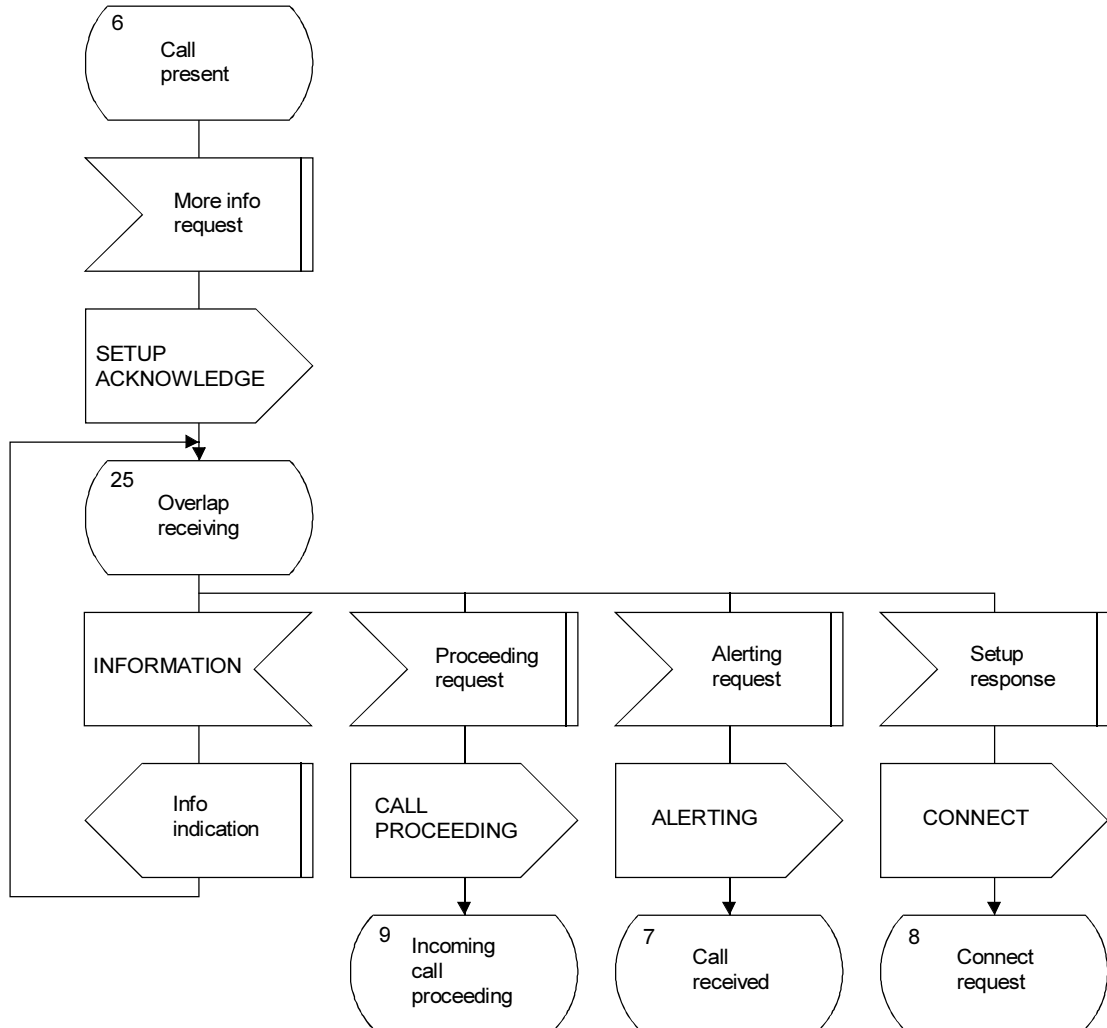

c) Overlap receiving procedure

FIGURE A.2/Q.931 (Sheet 5 of 7)
Overview protocol control (user side)

Superseded by a more recent version

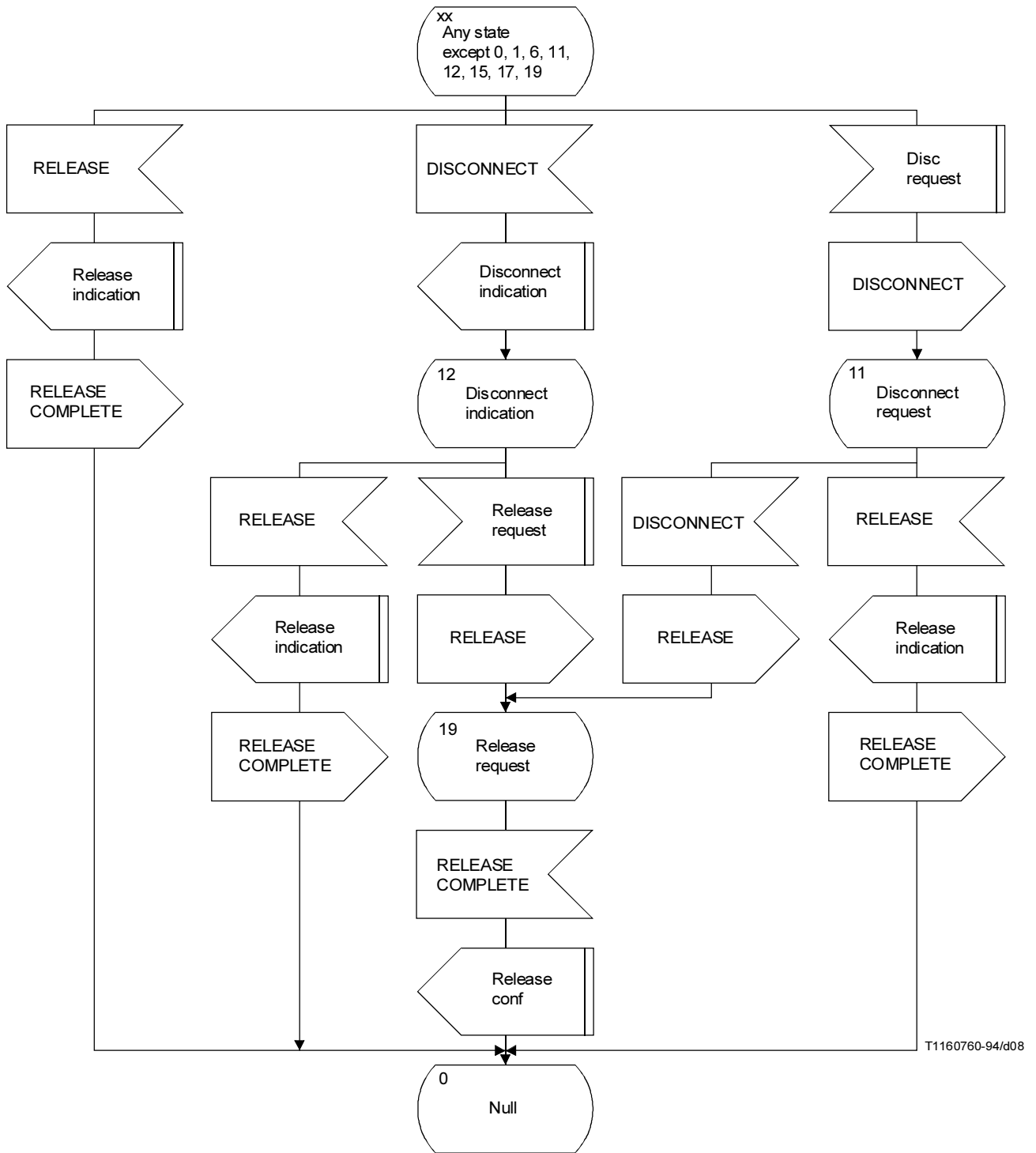

d) Clearing procedure

FIGURE A.2/Q.931 (Sheet 6 of 7)
Overview protocol control (user side)

Superseded by a more recent version

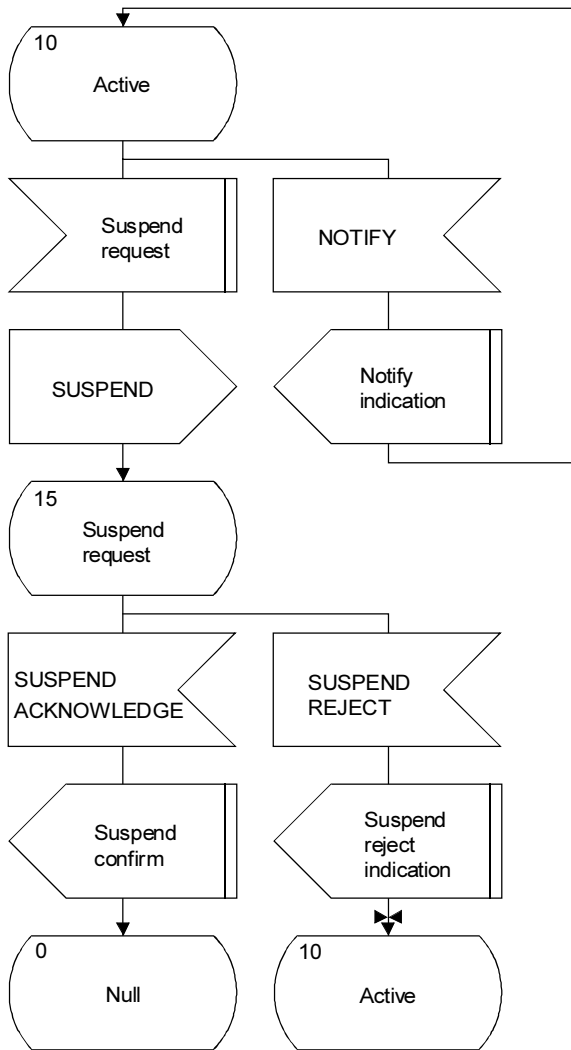

e) Suspend procedure

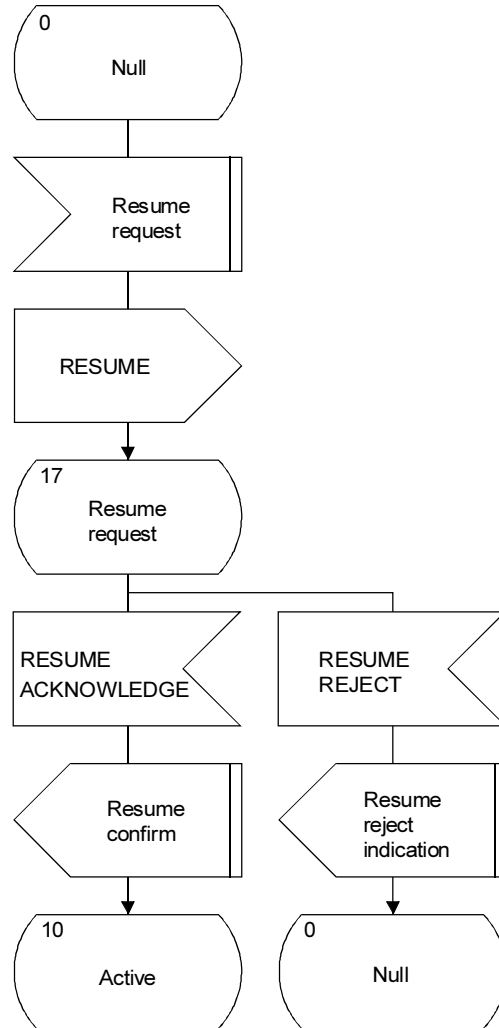

f) Resume procedure

T1160770-94/d09

FIGURE A.2/Q.931 (Sheet 7 of 7)
Overview protocol control (user side)

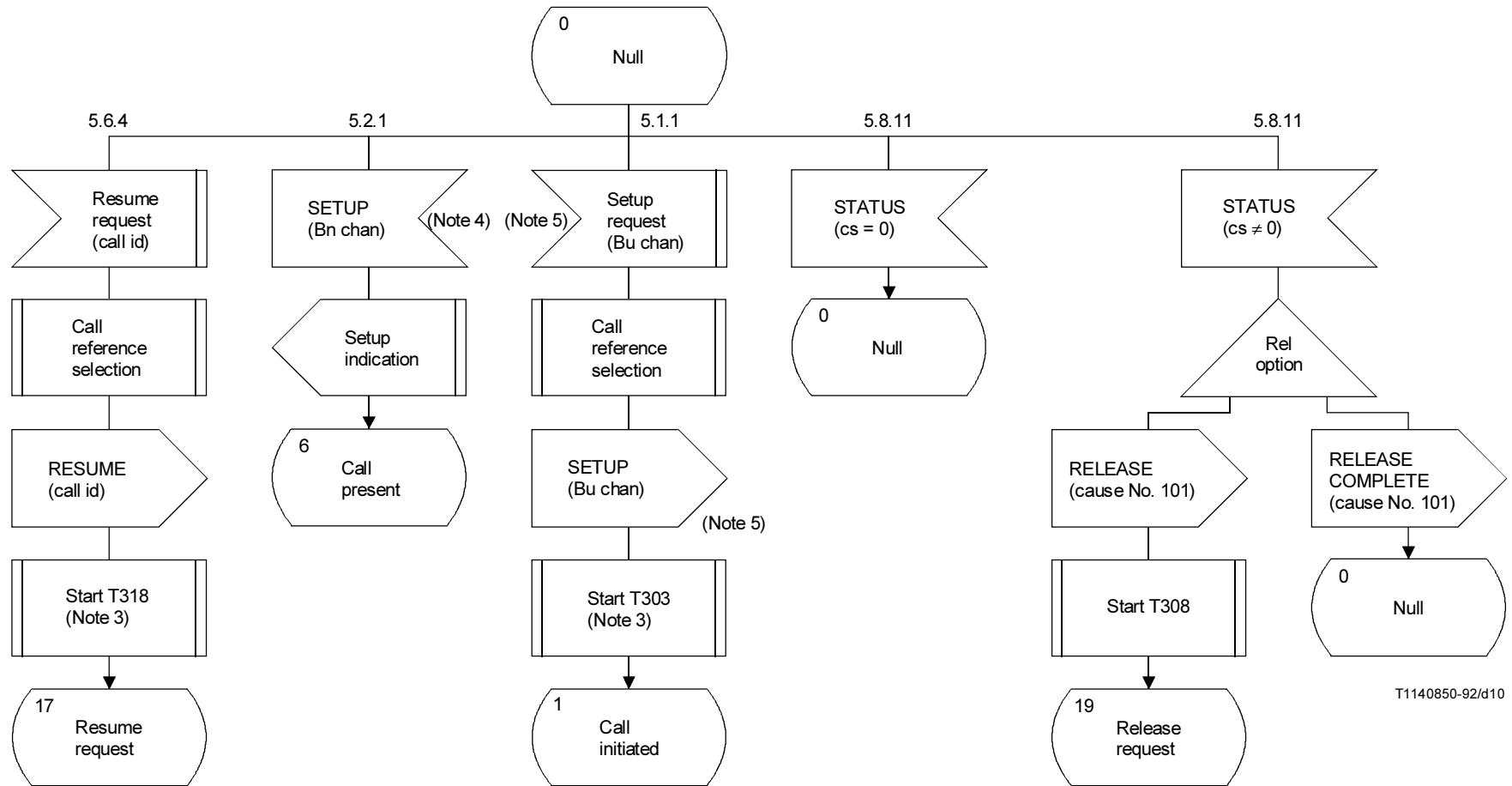

NOTES

- 1 In the event of conflict between these diagrams and the text of clause 5, the text should be the prime source.
- 2 These diagrams show Q.931 protocol control for circuit-switched calls.
- 3 T303 and T318 are optional (see 9.2).
- 4 “Bn chan” is a B-channel selected by the network.
- 5 “Bu chan” is a B-channel selected by the user.

FIGURE A.3/Q.931 (Sheet 1 of 25)
Detailed protocol control (user side)

Superseded by a more recent version

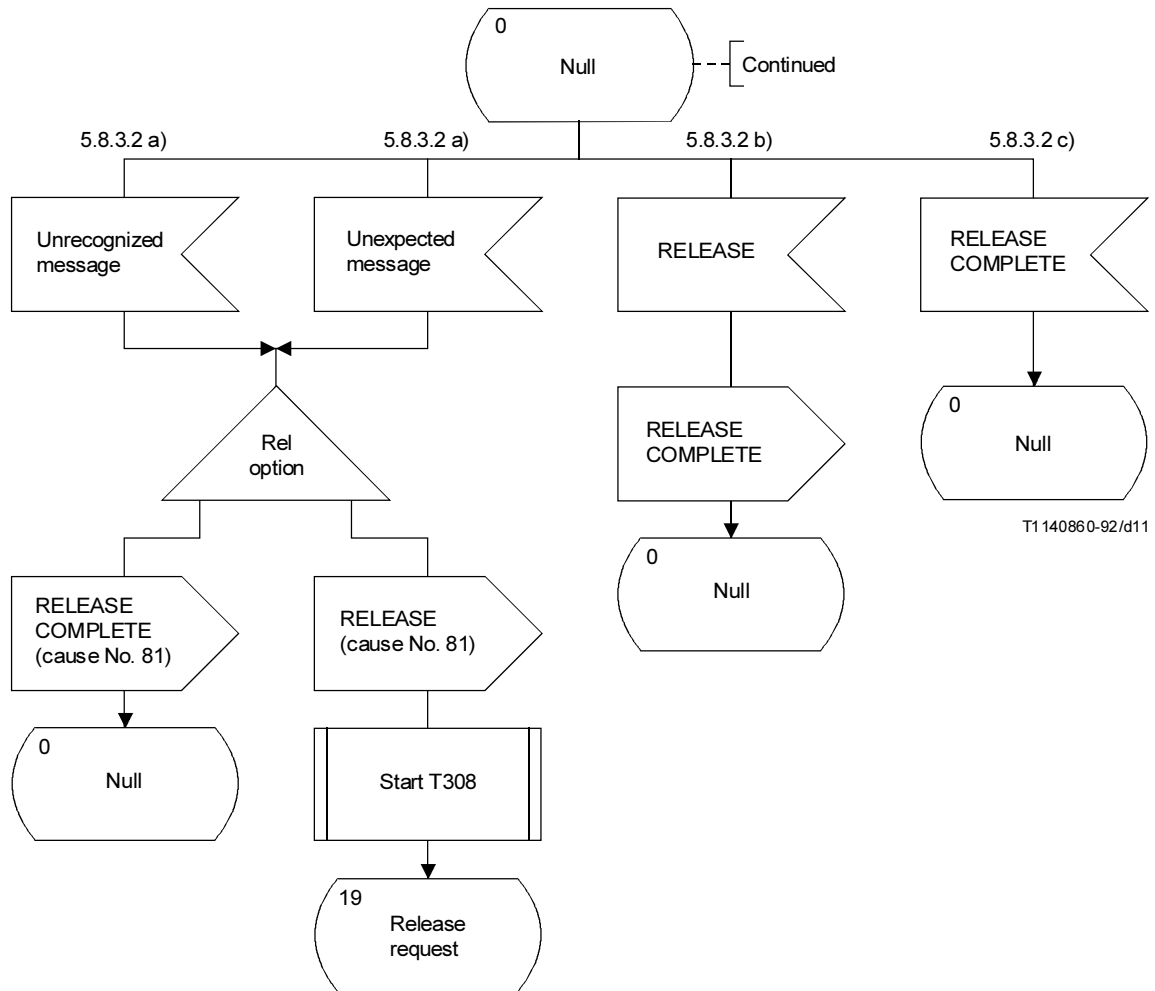
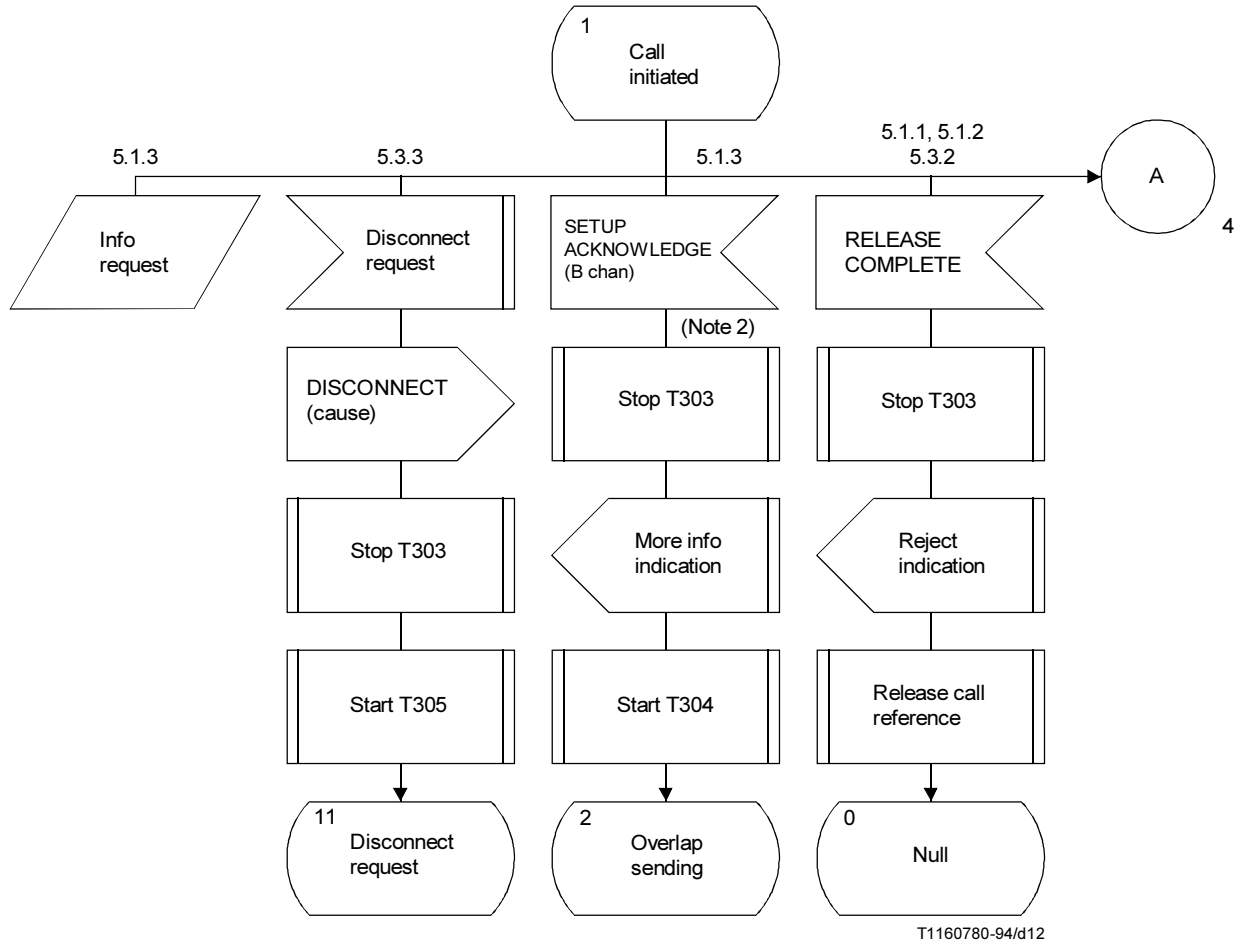

FIGURE A.3/Q.931 (Sheet 2 of 25)
Detailed protocol control (user side)

Superseded by a more recent version



NOTES

- 1 T303, T304 and T310 are optional (see 9.2).
- 2 "B chan" is a B-channel negotiated by the network and the user.

FIGURE A.3/Q.931 (Sheet 3 of 25)
Detailed protocol control (user side)

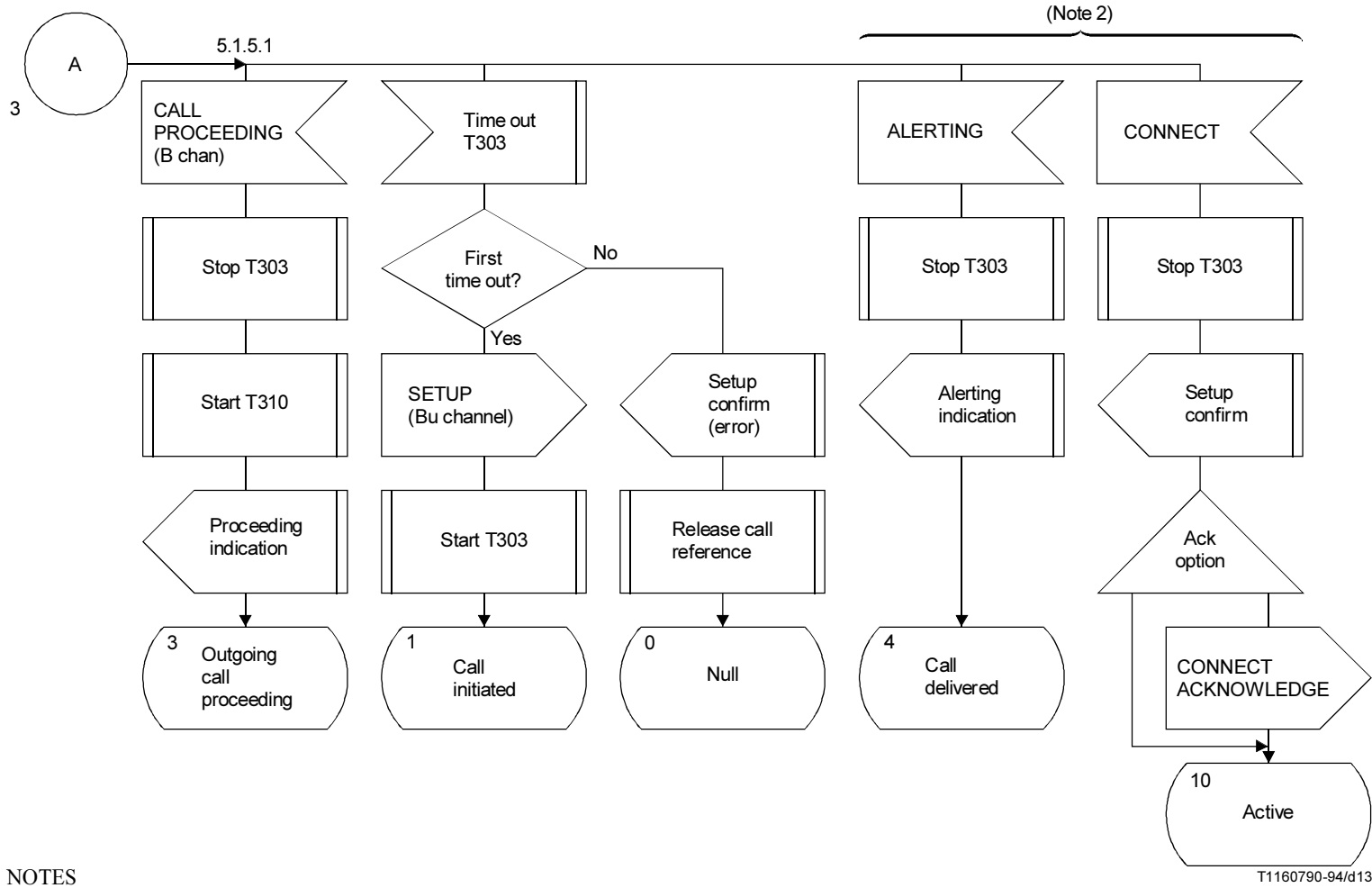

NOTES

- 1 T303, T304 and T310 are optional (see 9.2).
- 2 Only applicable for the procedure defined in Annex D.
- 3 "B chan" is a B-channel negotiated by the network and the user.

FIGURE A.3/Q.931 (Sheet 4 of 25)
Detailed protocol control (user side)

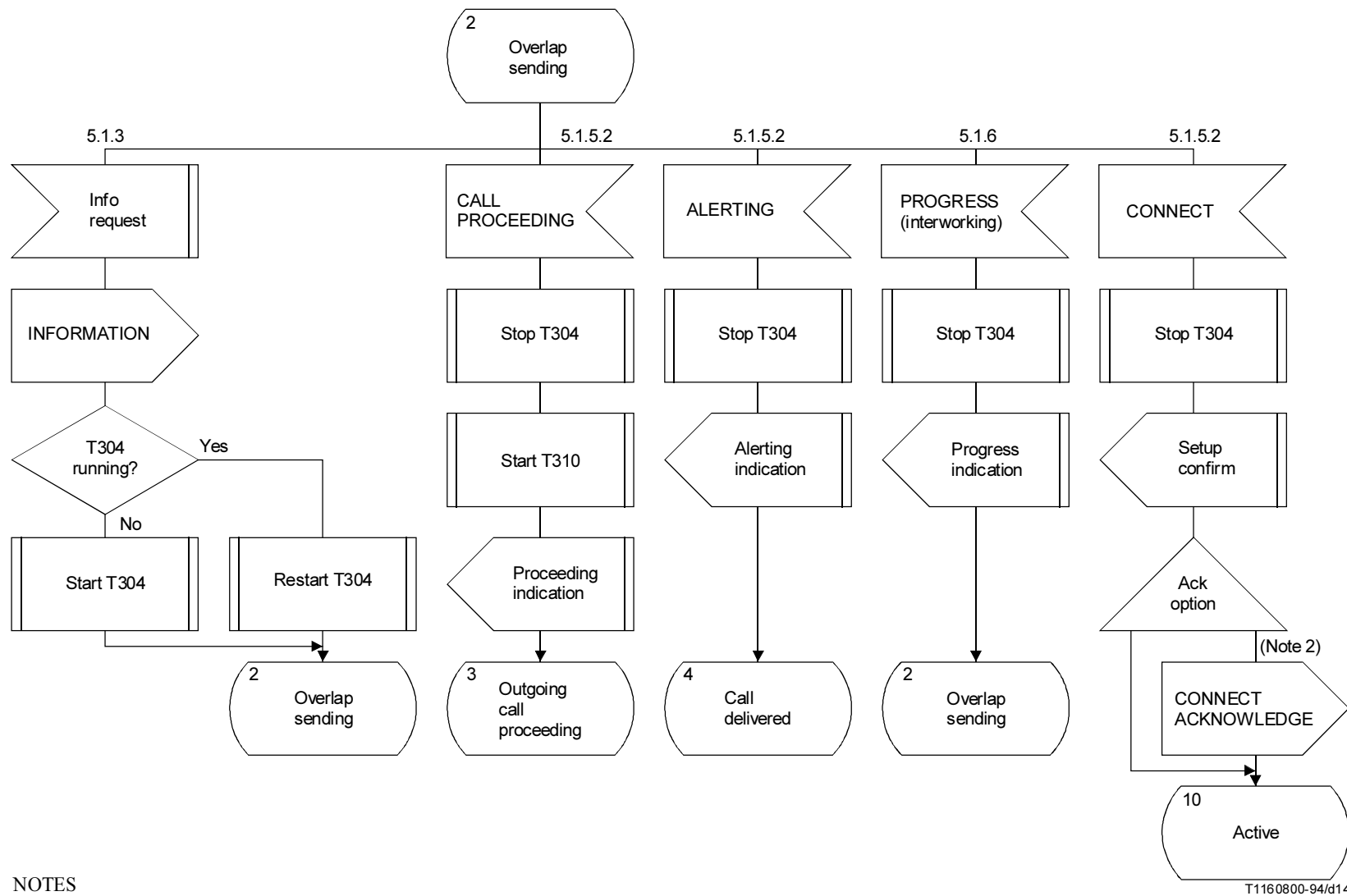

NOTES

- 1 T304 and T310 are optional (see 9.2).
- 2 This option is used when the procedure in Annex D is implemented.

T1160800-94/d14

FIGURE A.3/Q.931 (Sheet 5 of 25)
Detailed protocol control (user side)

Superseded by a more recent version

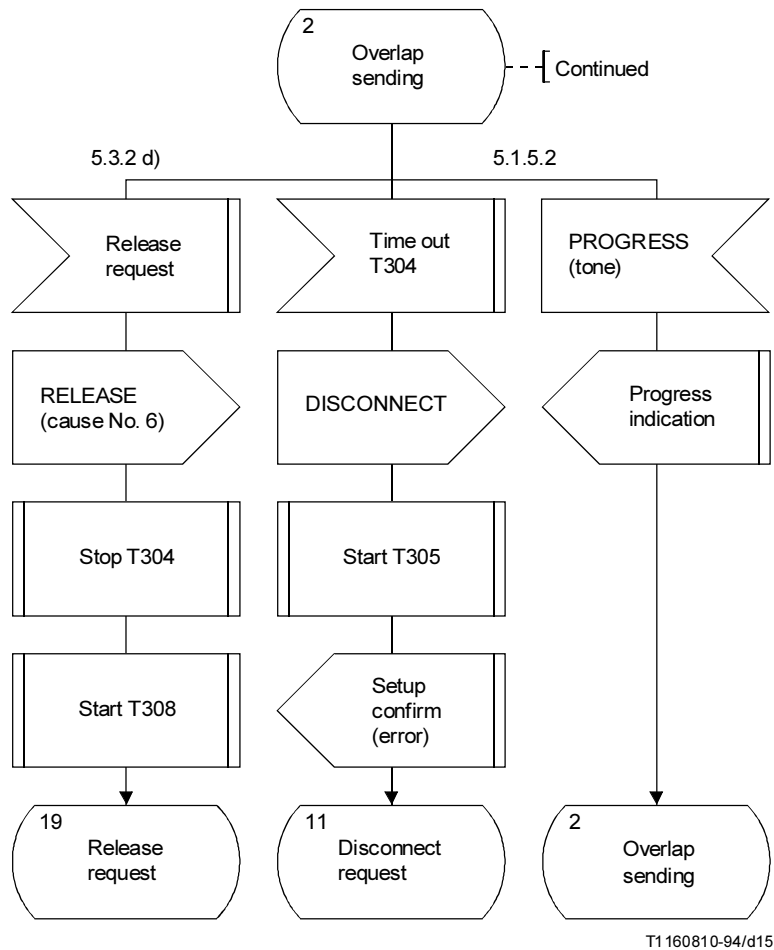

NOTE – T304 is optional (see 9.2).

FIGURE A.3/Q.931 (Sheet 6 of 25)
Detailed protocol control (user side)

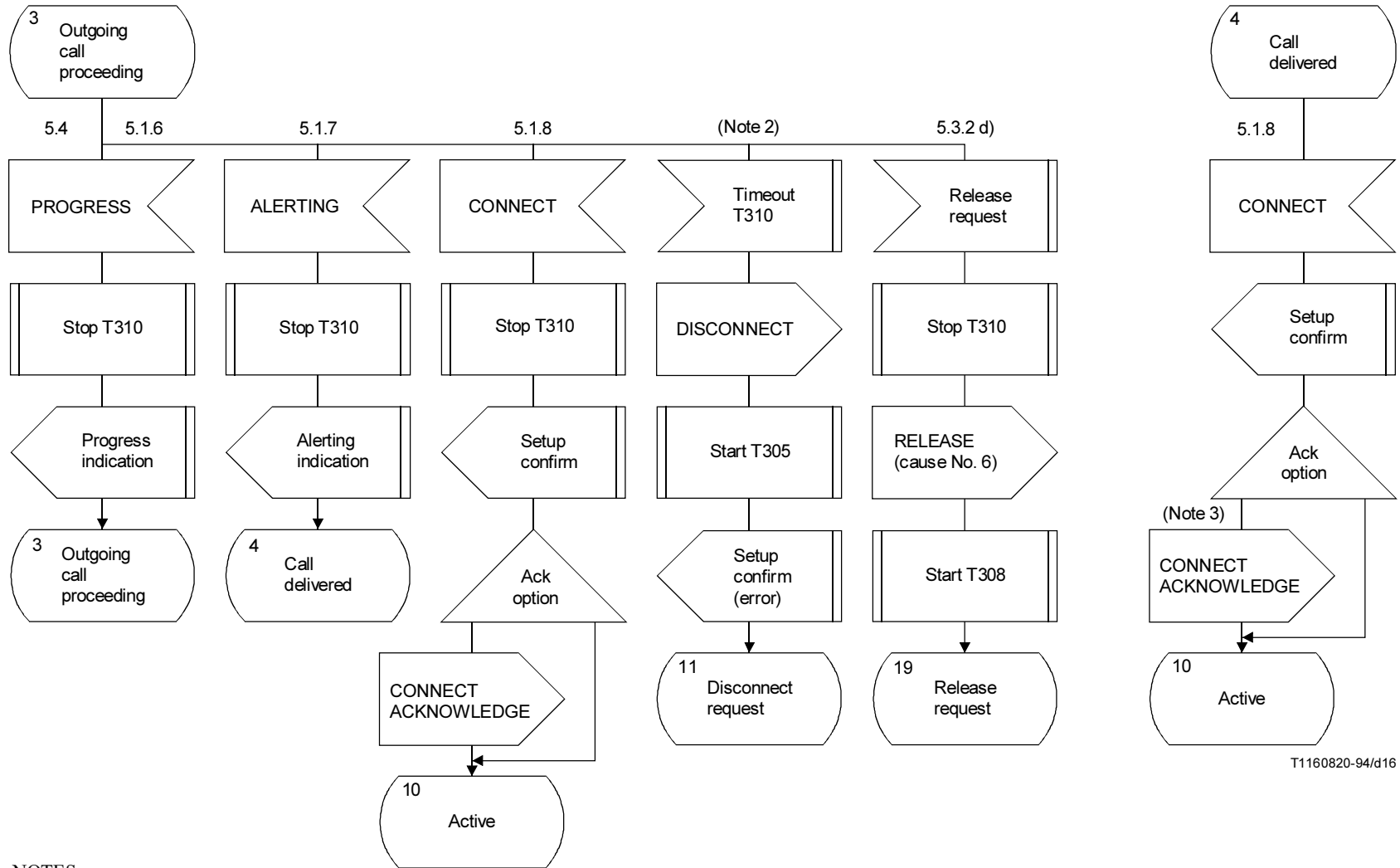

Superseded by a more recent version

FIGURE A.3/Q.931 (Sheet 7 of 25)
Detailed protocol control (user side)

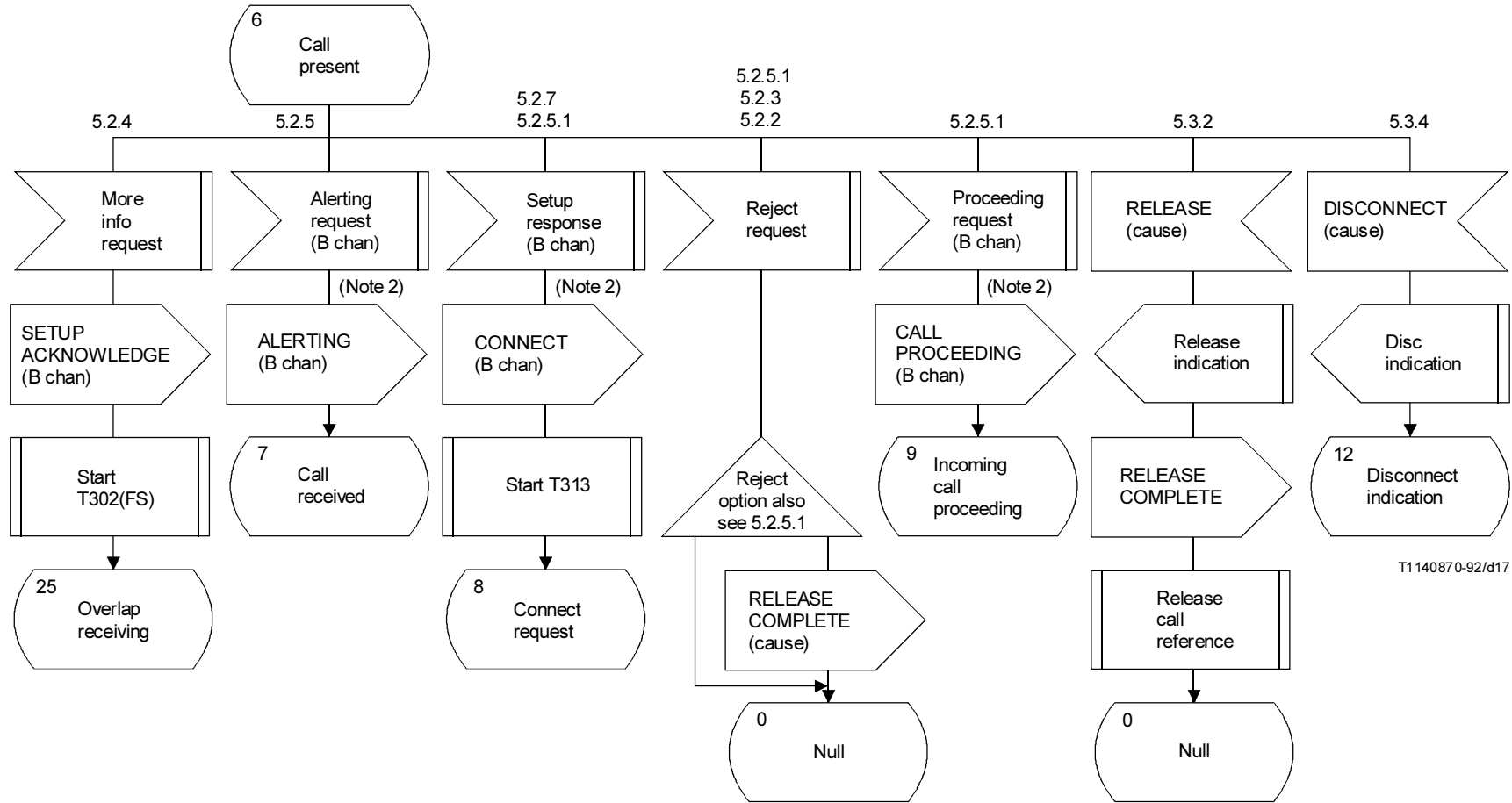

NOTES

- 1 T302 is optional (see 9.2).
- 2 "B chan" is a B-channel negotiated by the network and the user.

FIGURE A.3/Q.931 (Sheet 8 of 25)

Detailed protocol control (user side)

Superseded by a more recent version

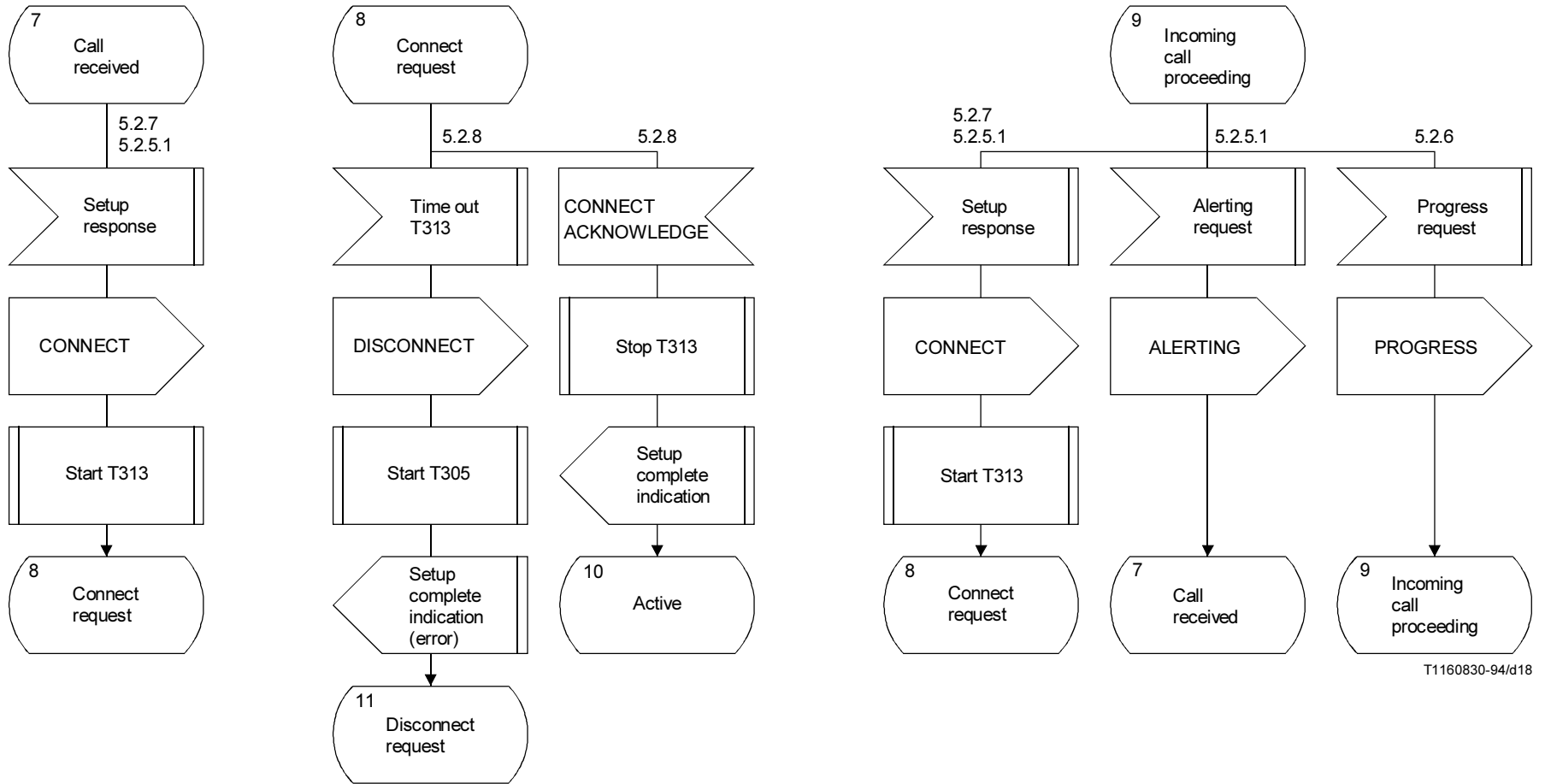

FIGURE A.3/Q.931 (Sheet 9 of 25)
Detailed protocol control (user side)

Superseded by a more recent version

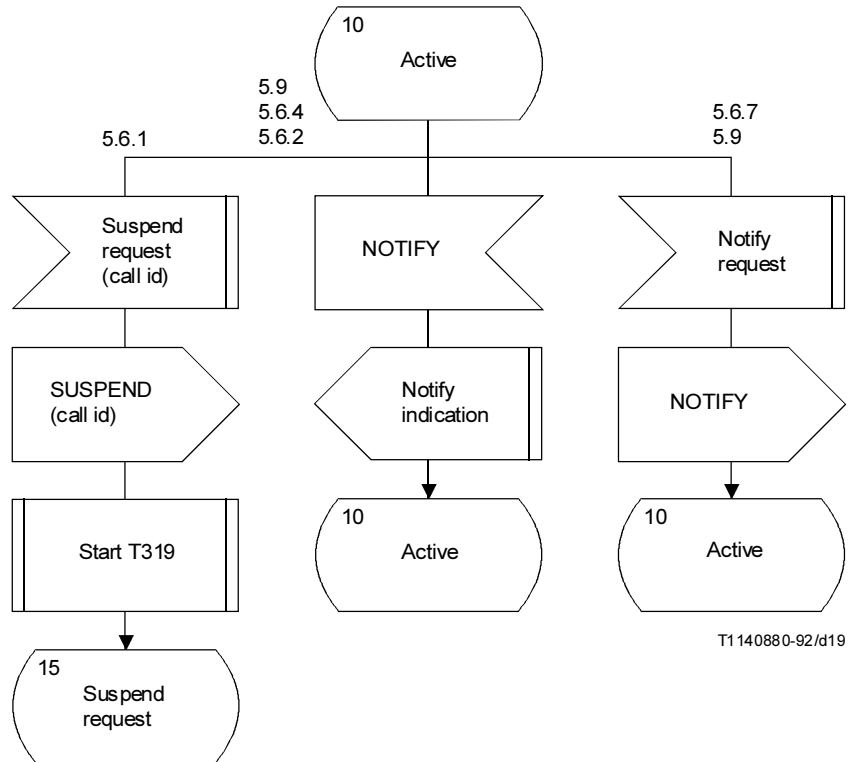
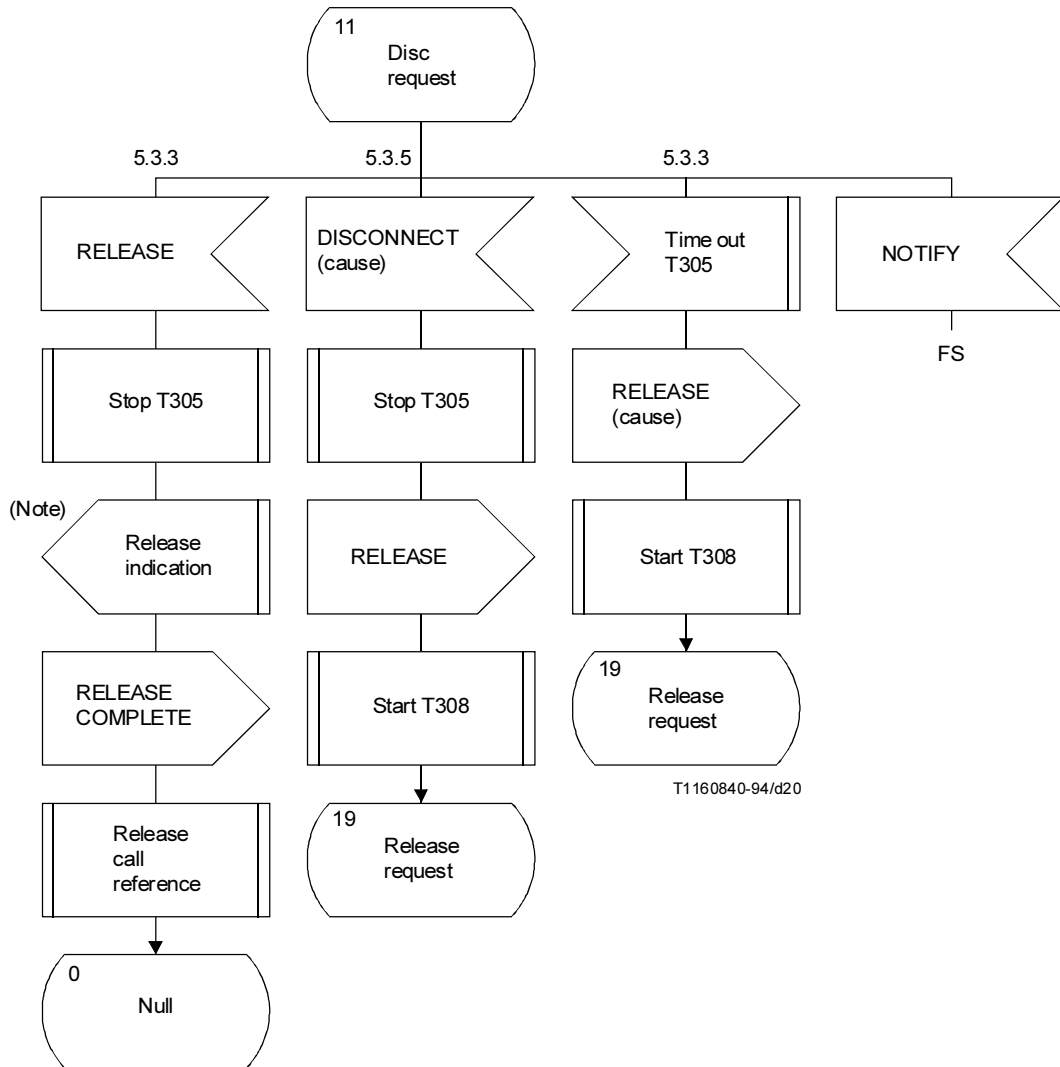

FIGURE A.3/Q.931 (Sheet 10 of 25)
Detailed protocol control (user side)

Superseded by a more recent version



NOTE – After receiving this primitive, call control process should release B-channel.

FIGURE A.3/Q.931 (Sheet 11 of 25)
Detailed protocol control (user side)

Superseded by a more recent version

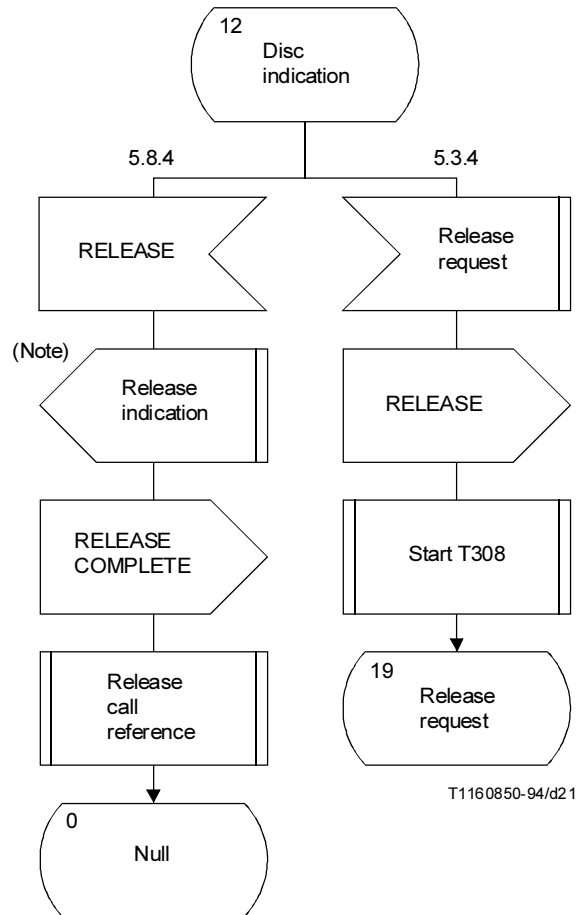

T1160850-94/d2.1

NOTE – After receiving this primitive, call control process should release B-channel.

FIGURE A.3/Q.931 (Sheet 12 of 25)
Detailed protocol control (user side)

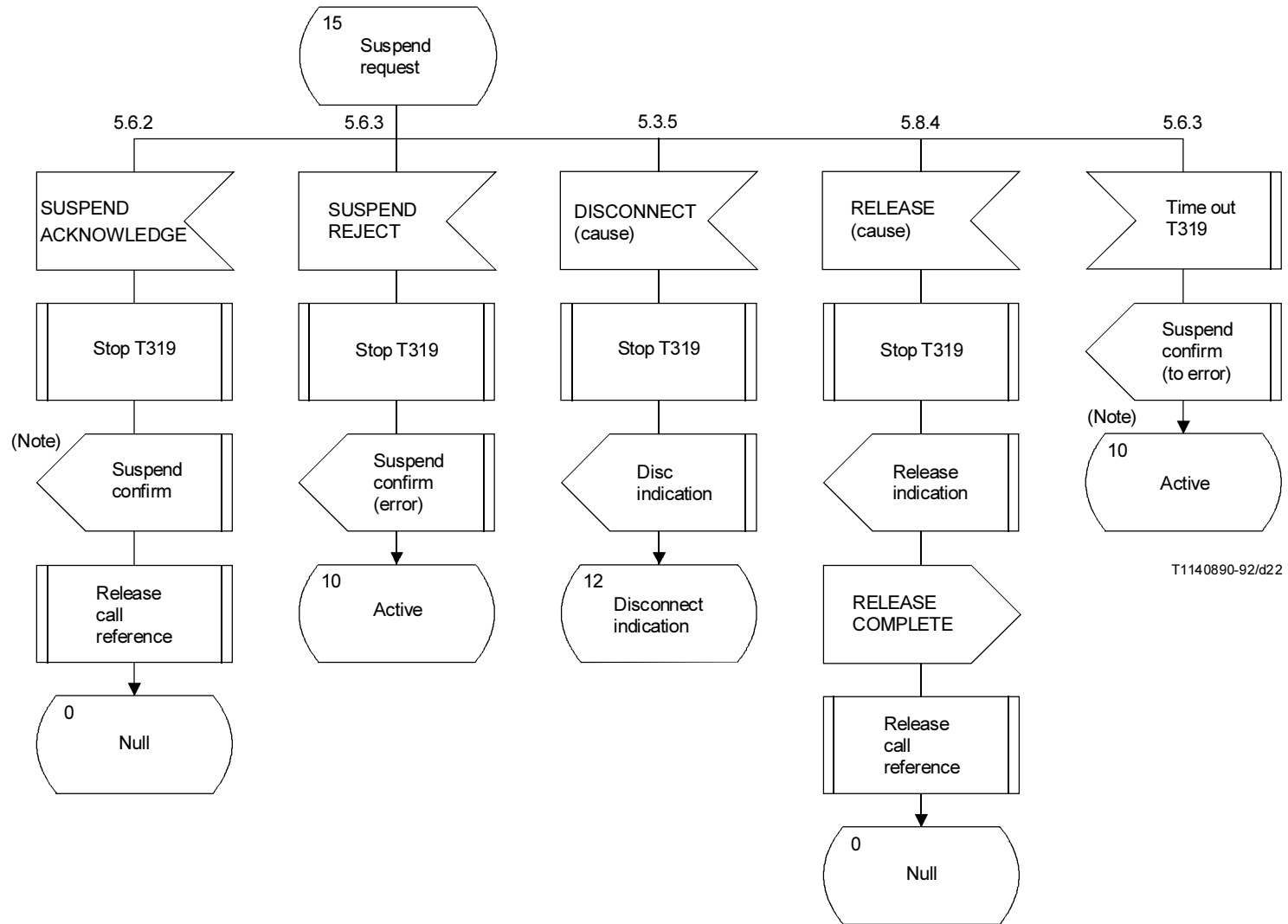

NOTE – After receiving this primitive, call control process should release B-channel.

FIGURE A.3/Q.931 (Sheet 13 of 25)
Detailed protocol control (user side)

Superseded by a more recent version

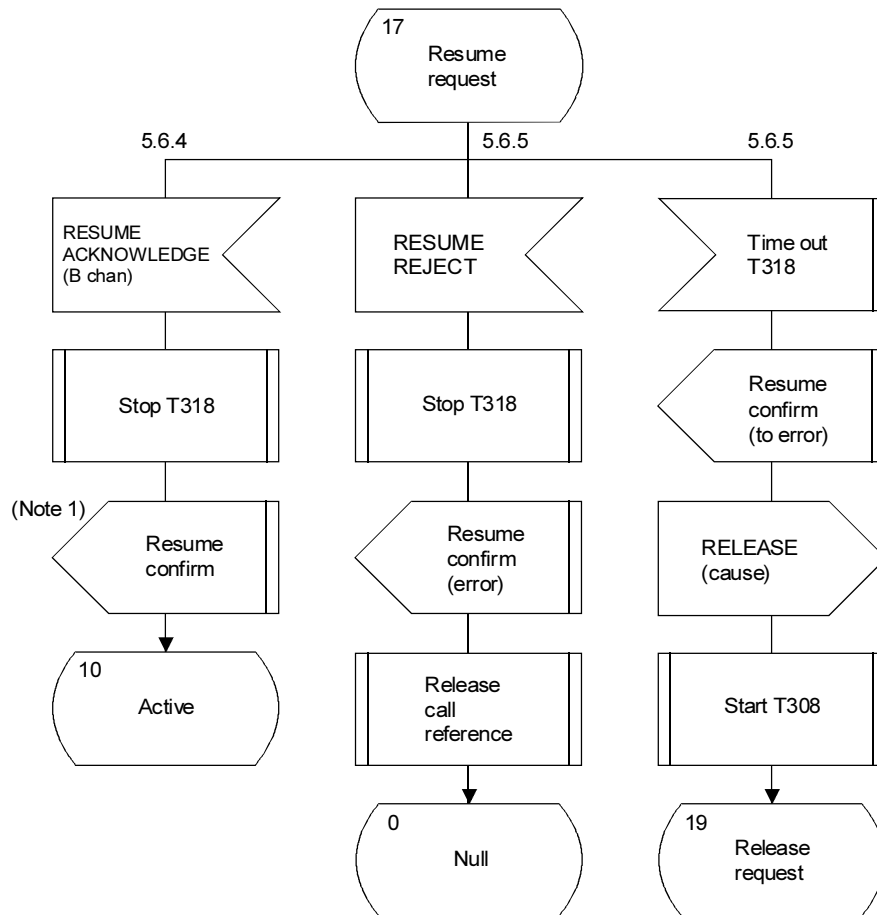

T1140900-92/d23

NOTES

- 1 After receiving this primitive, call control process should connect B-channel.
- 2 Open issue: Handling of disconnect request primitive.

FIGURE A.3/Q.931 (Sheet 14 of 25)
Detailed protocol control (user side)

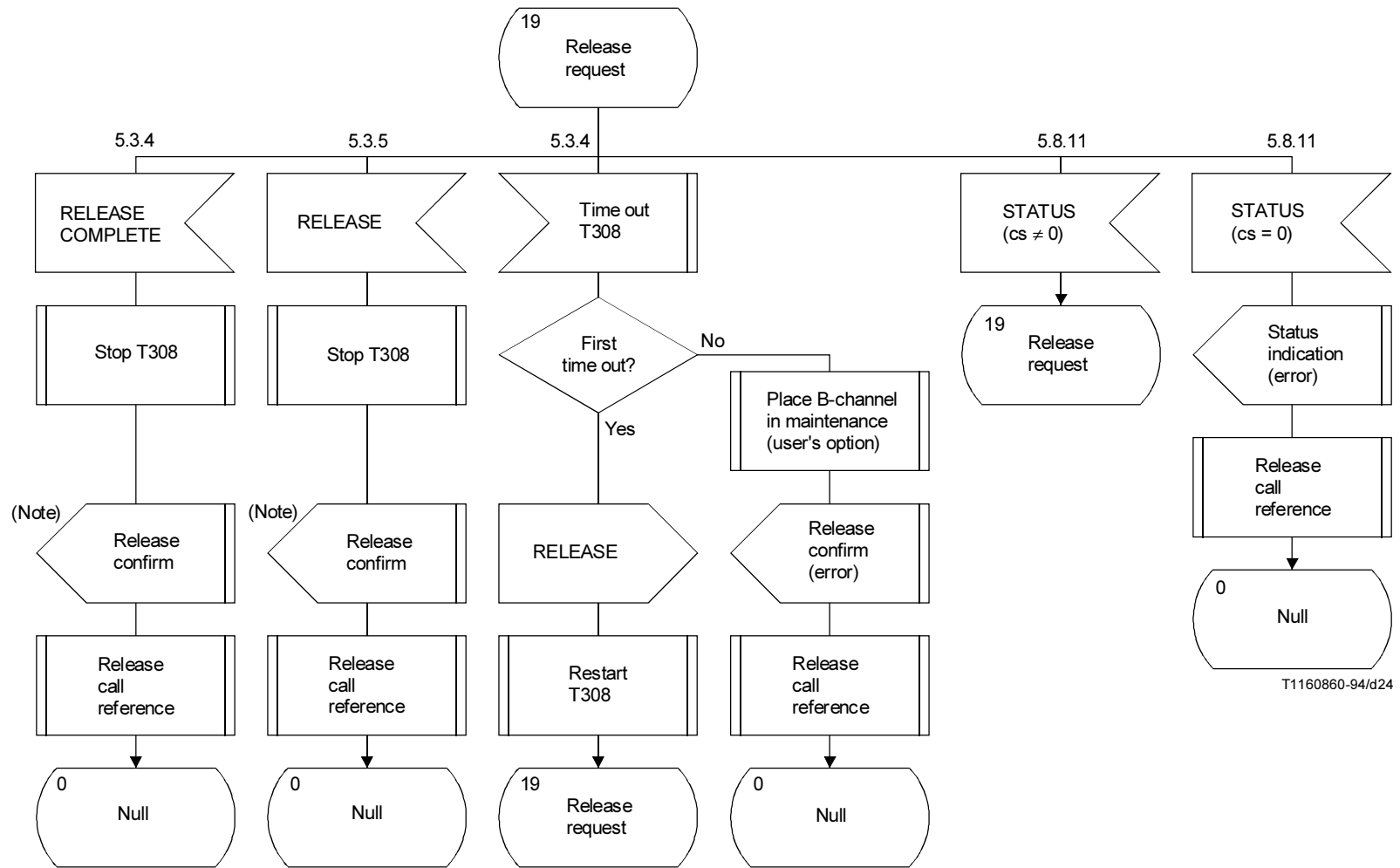

NOTE – After receiving this primitive, call control process should release B-channel.

FIGURE A.3/Q.931 (Sheet 15 of 25)
Detailed protocol control (user side)

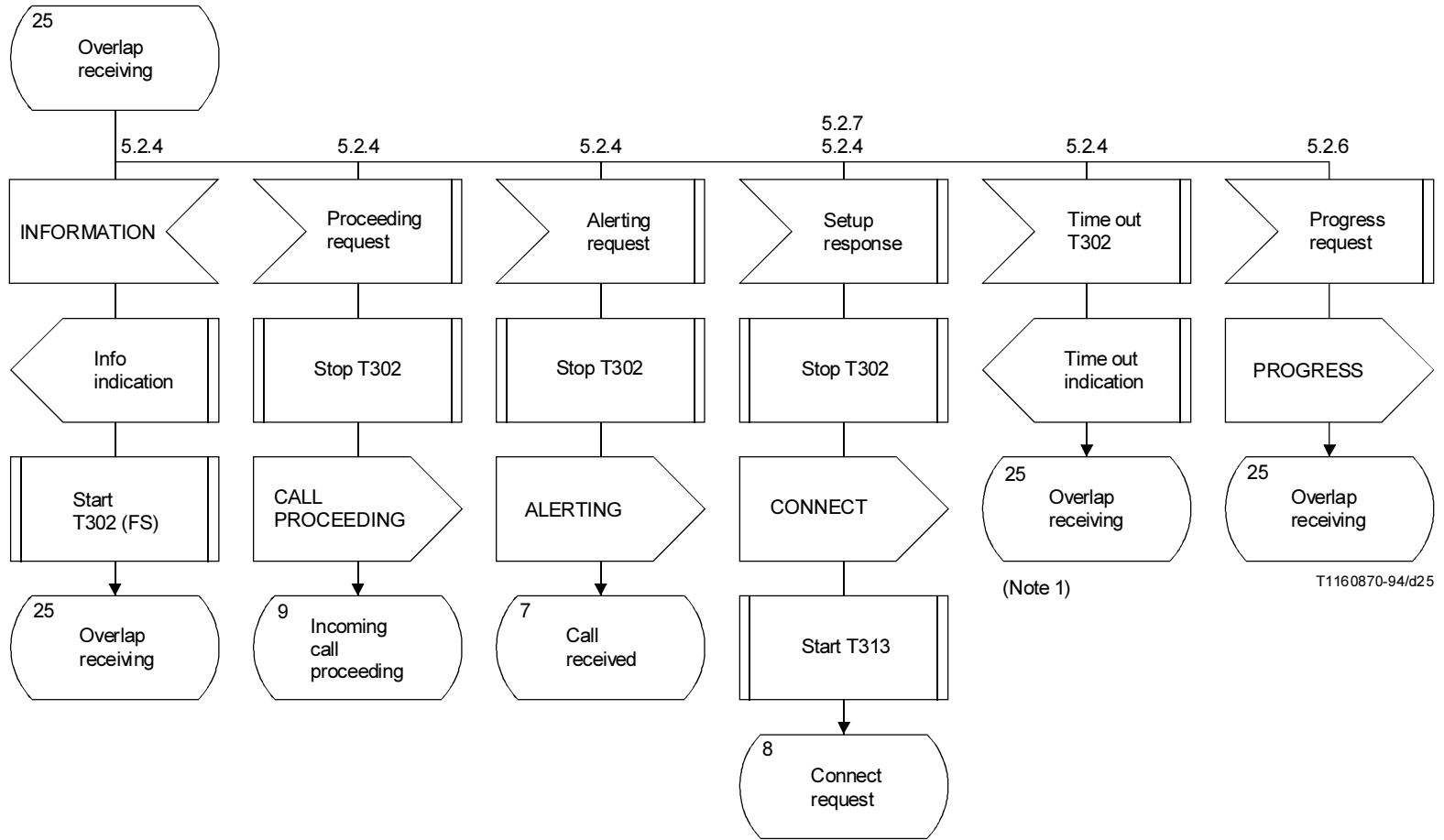

NOTES

- 1 It is assumed that the decision whether complete information has been received or not, at the expiry of T302, will be made by the call control.
- 2 T302 is optional (see 9.2).

FIGURE A.3/Q.931 (Sheet 16 of 25)

Detailed protocol control (user side)

Superseded by a more recent version

Superseded by a more recent version

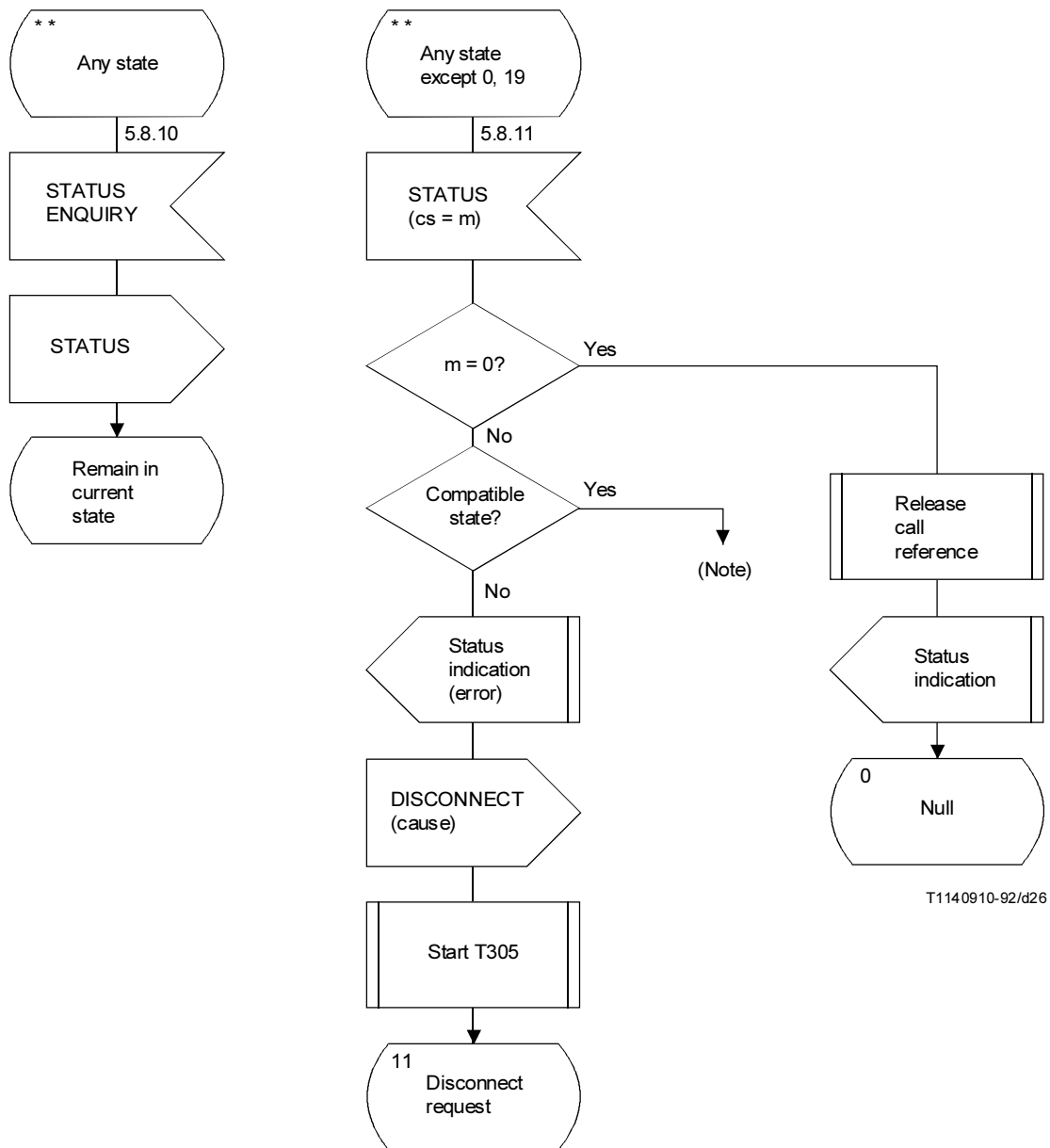

T1140910-92/d26

NOTE – Action on receipt of STATUS indicating a compatible call state is implementation dependent (see 5.8.11).

FIGURE A.3/Q.931 (Sheet 17 of 25)
Detailed protocol control (user side)

Superseded by a more recent version

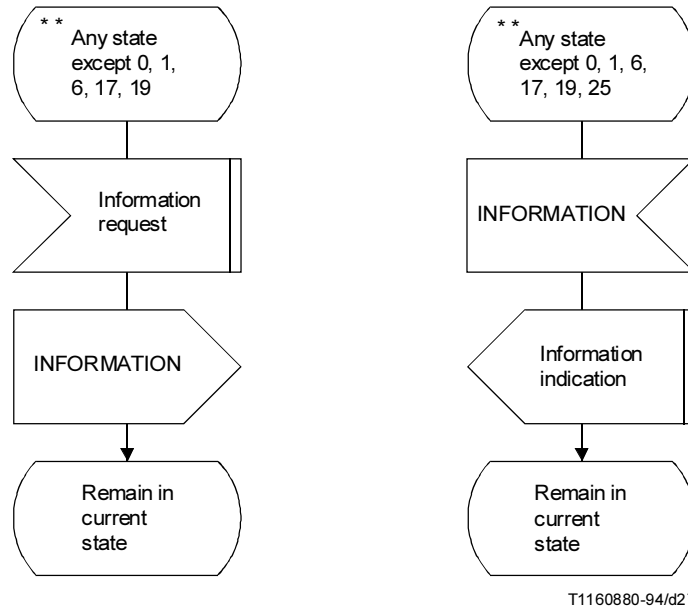
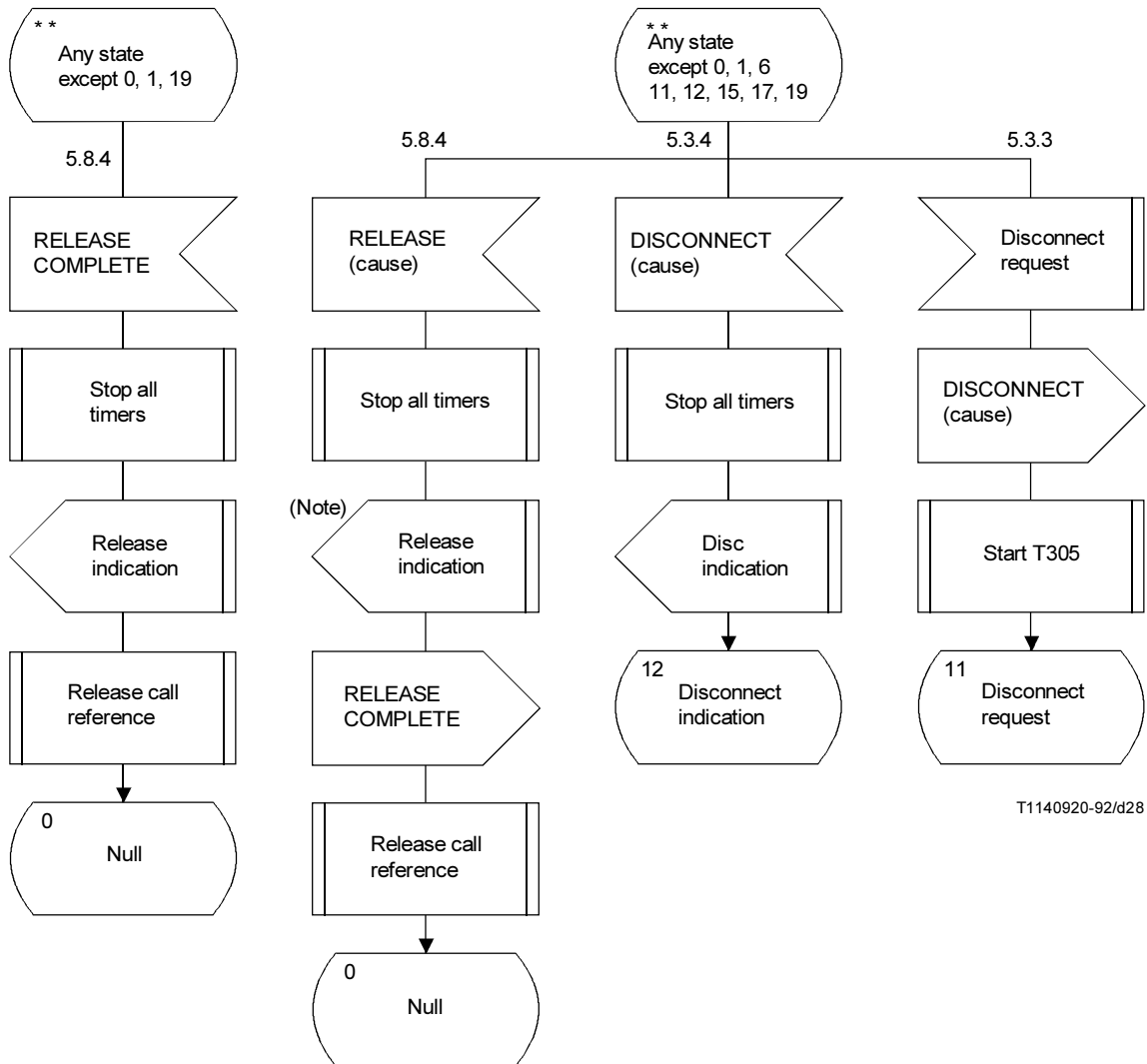

FIGURE A.3/Q.931 (Sheet 18 of 25)
Detailed protocol control (user side)

Superseded by a more recent version



NOTE – After receiving this primitive, call control process should release B-channel.

FIGURE A.3/Q.931 (Sheet 19 of 25)
Detailed protocol control (user side)

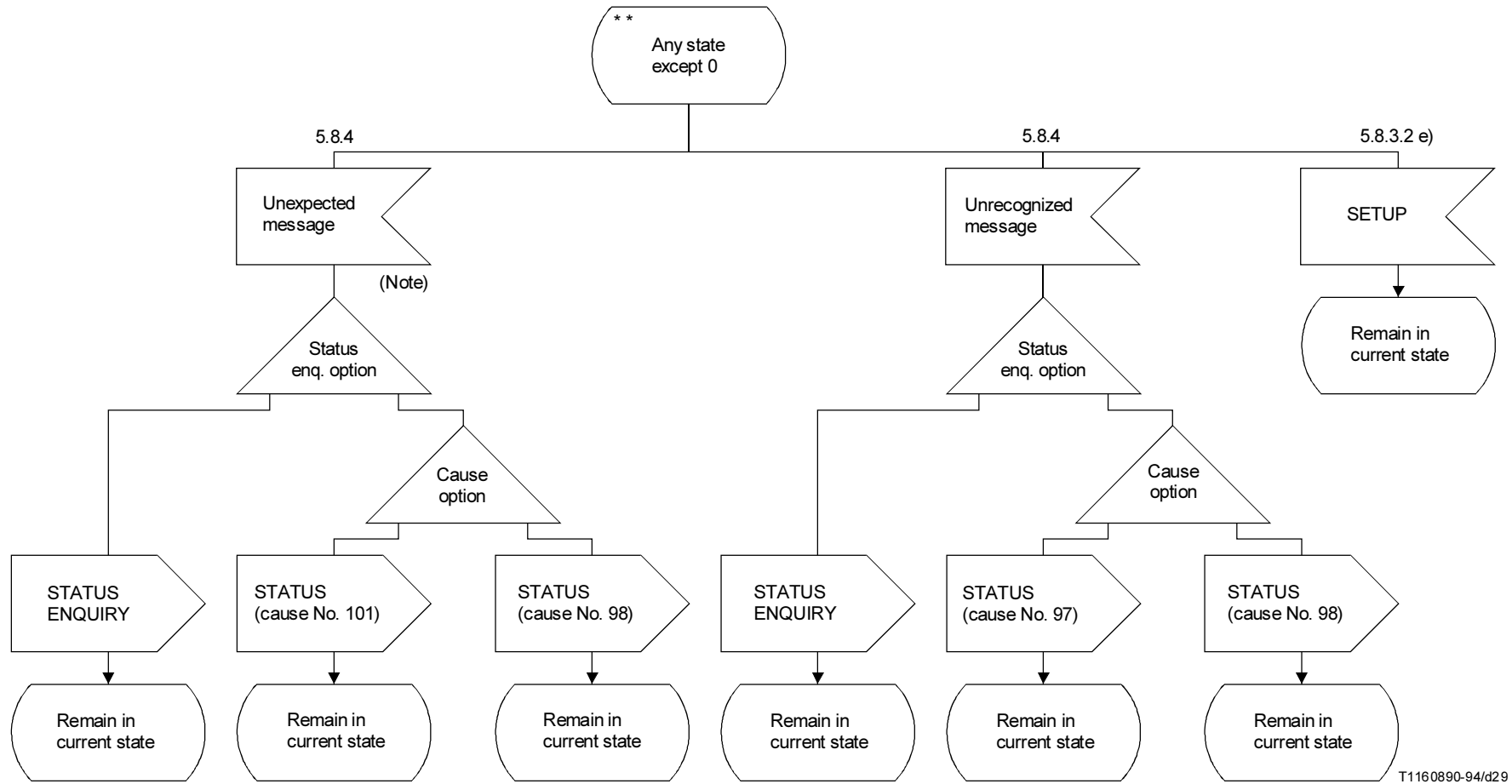

T1160890-94/d29

NOTE – Except RELEASE or RELEASE COMPLETE.

FIGURE A.3/Q.931 (Sheet 20 of 25)
Detailed protocol control (user side)

Superseded by a more recent version

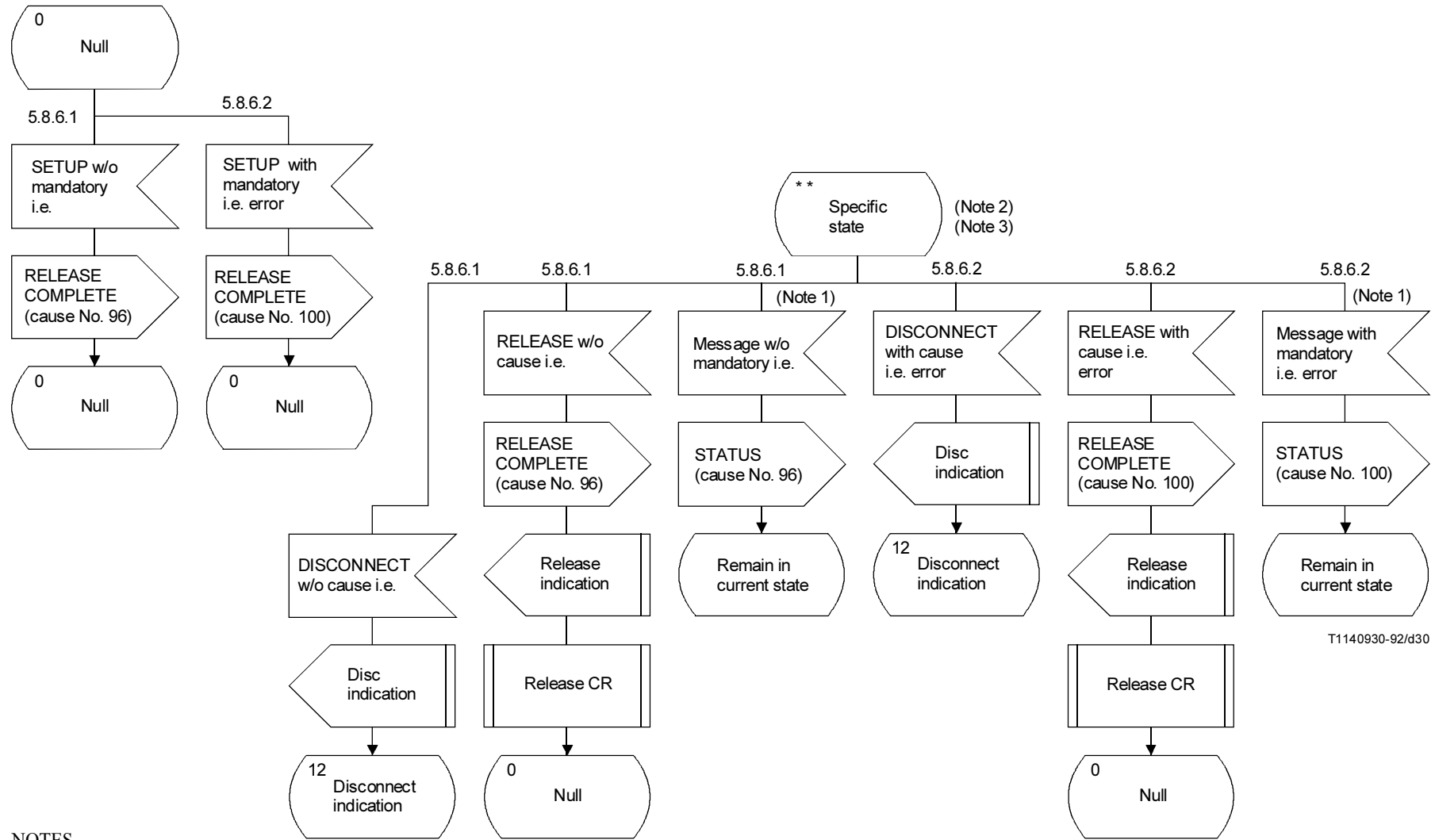

T1140930-92/d30

NOTES

- 1 Except SETUP, RELEASE, RELEASE COMPLETE and DISCONNECT.
- 2 These messages are recognized by the user ans expected messages in the state. [See Figure A.3 (Sheet 15 of 25)].
- 3 See 5.8.6 procedures for specific states.

FIGURE A.3/Q.931 (Sheet 21 of 25)
Detailed protocol control (user side)

Superseded by a more recent version

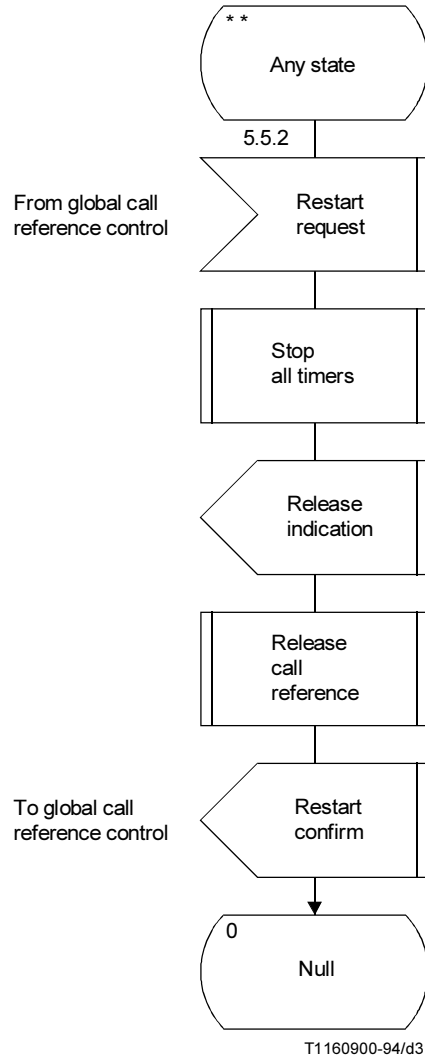
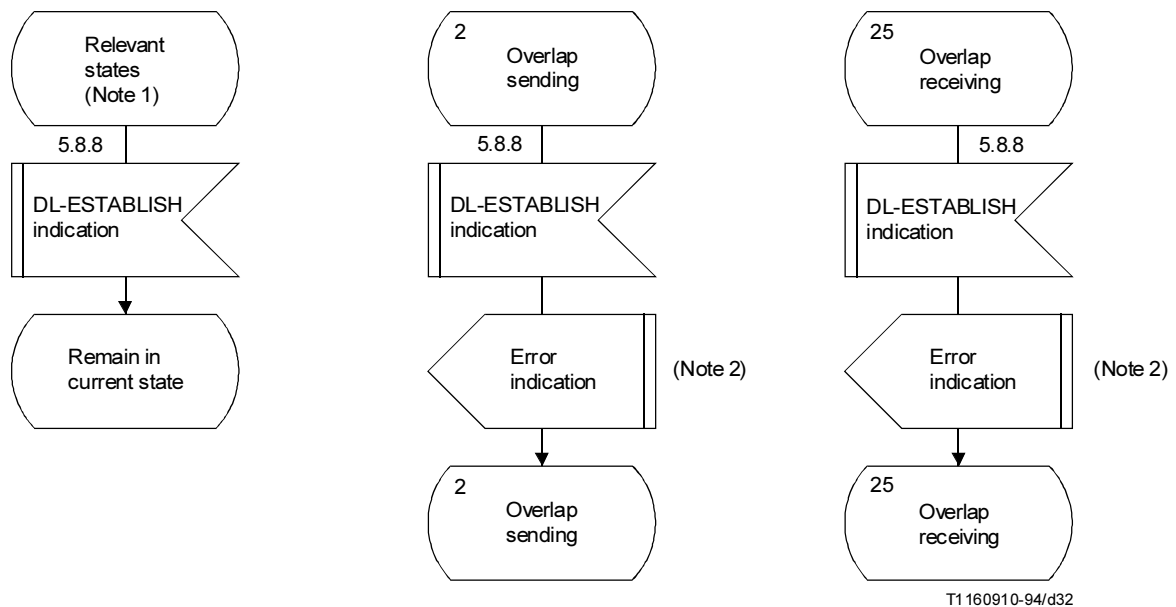

FIGURE A.3/Q.931 (Sheet 22 of 25)
Detailed protocol control (user side)

Superseded by a more recent version



T1 160910-94/d32

NOTES

- 1 The relevant states are as follows: U1, U3, U4, U6 to U12, U15, U17, U19.
- 2 At the reception of this primitive, the call control should clear the call by sending disconnect request primitives.

FIGURE A.3/Q.931 (Sheet 23 of 25)
Detailed protocol control (user side)

Superseded by a more recent version

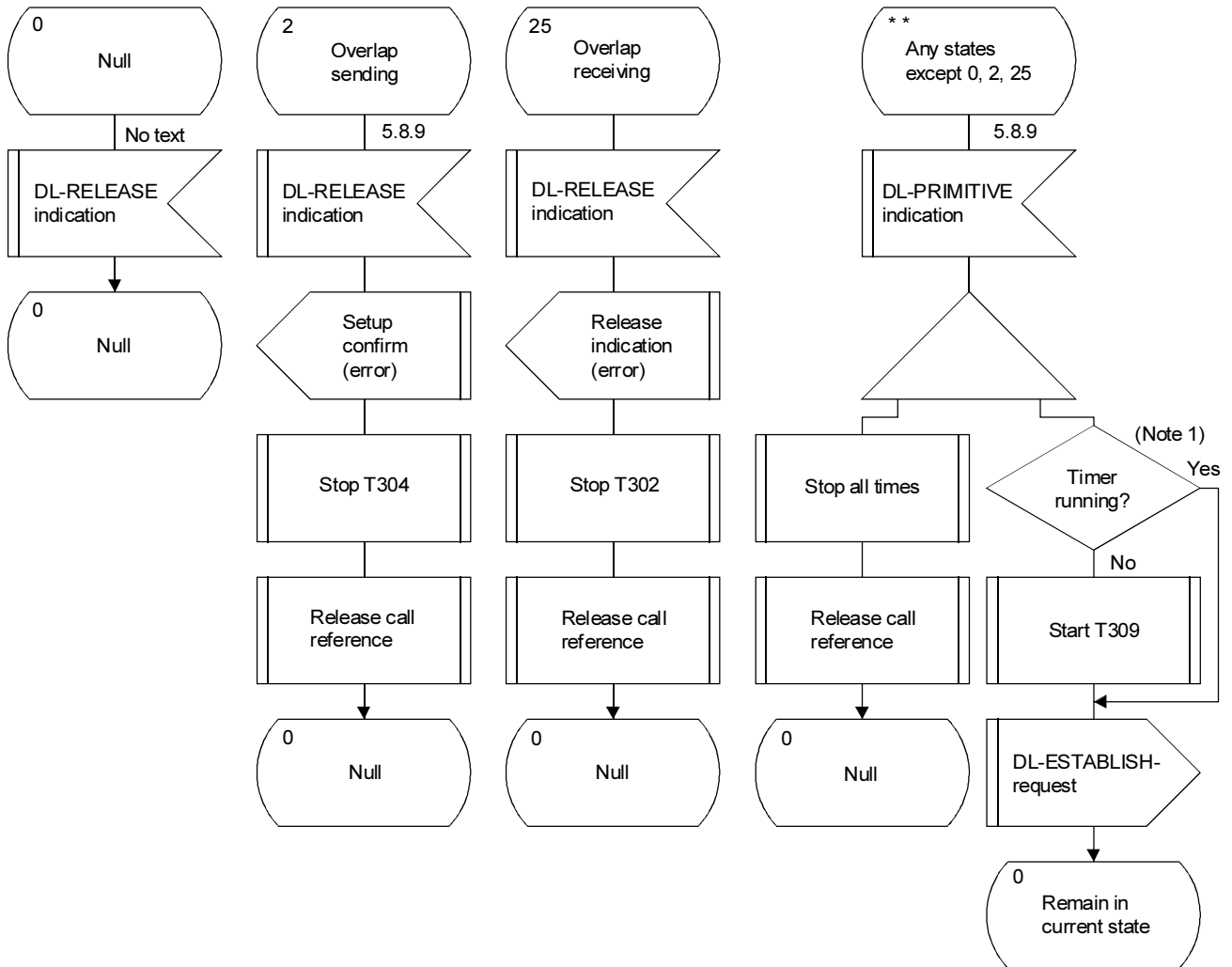

T1160920-94/d33

NOTES

- 1 Any timers including T309.
- 2 T309 is optional (see 9.2).

FIGURE A.3/Q.931 (Sheet 24 of 25)
Detailed protocol control (user side)

Superseded by a more recent version

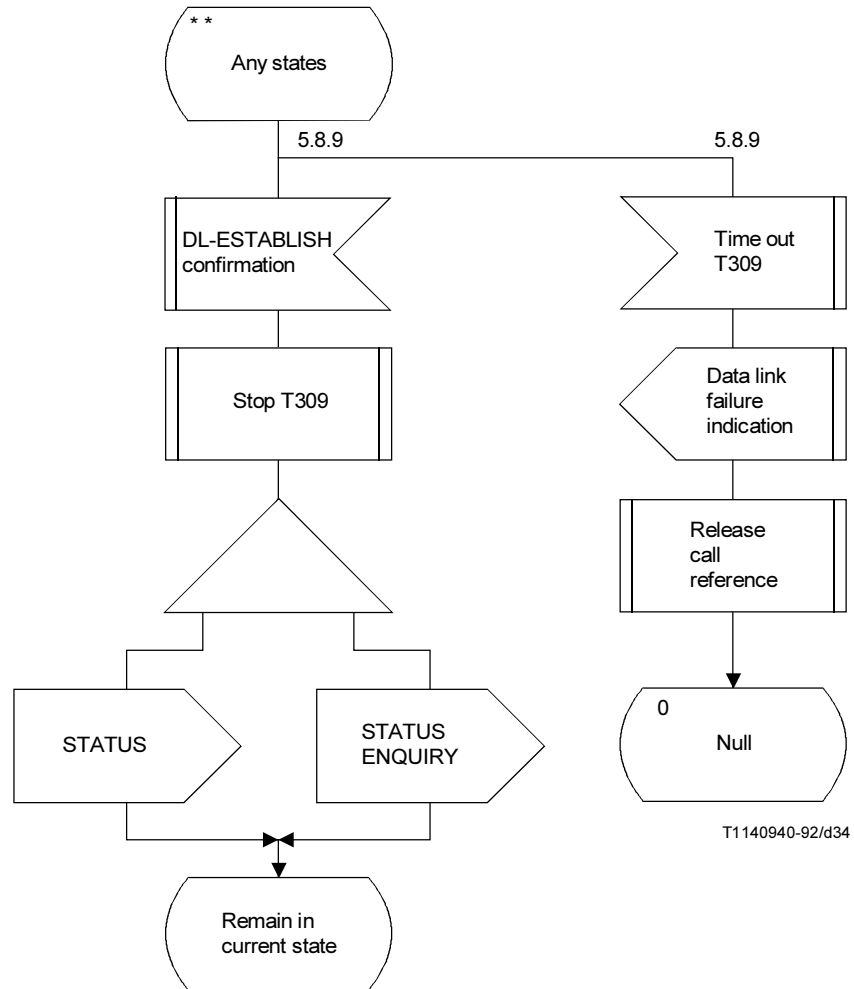

NOTE – T309 is optional (see 9.2).

FIGURE A.3/Q.931 (Sheet 25 of 25)
Detailed protocol control (user side)

Superseded by a more recent version

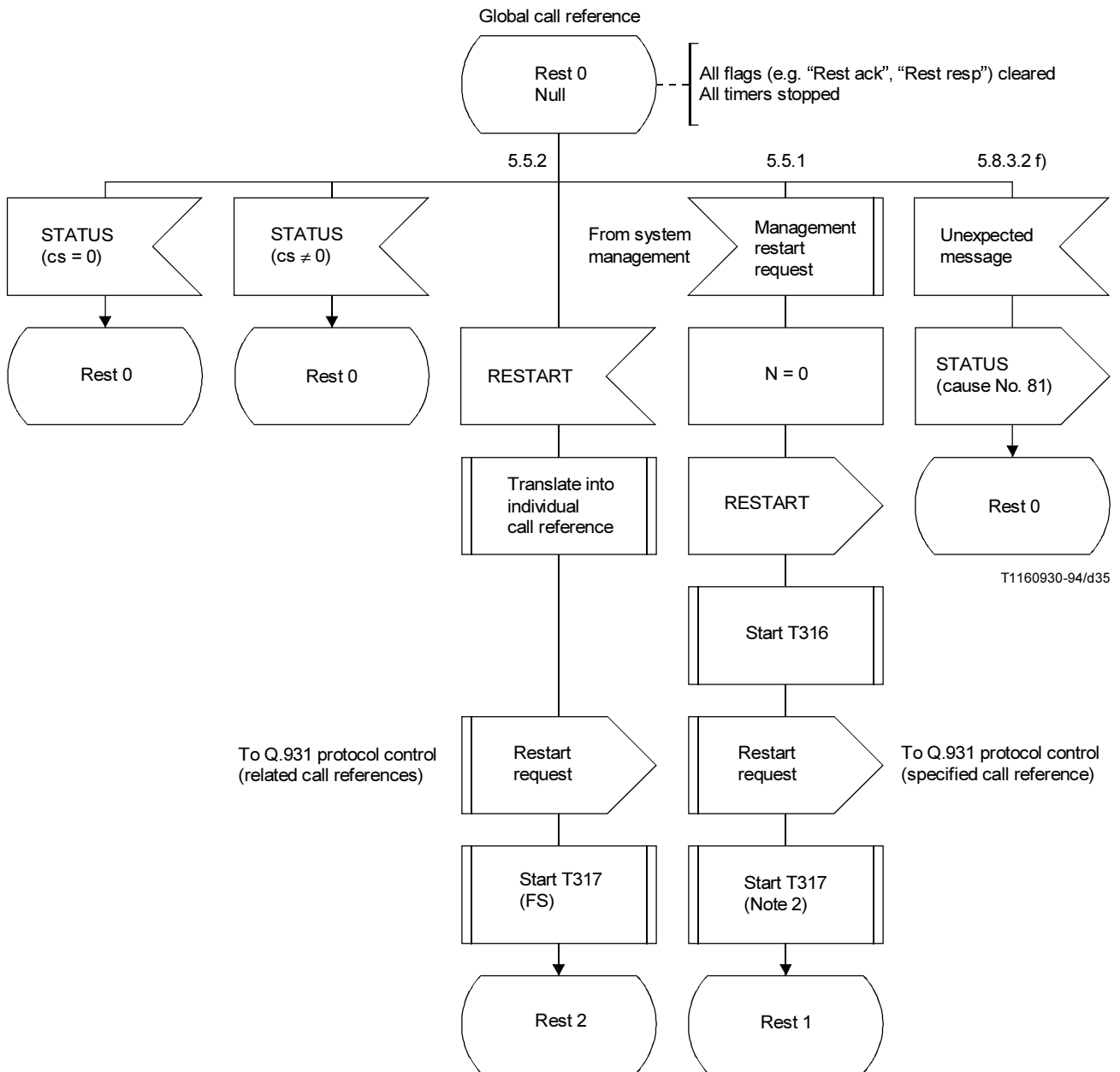

NOTES

- 1 T316 and T317 are optional (see 9.2).
- 2 The value of T317 is implementation dependent.

FIGURE A.4/Q.931 (Sheet 1 of 4)
Detailed protocol control for the global call reference (user side)

Superseded by a more recent version

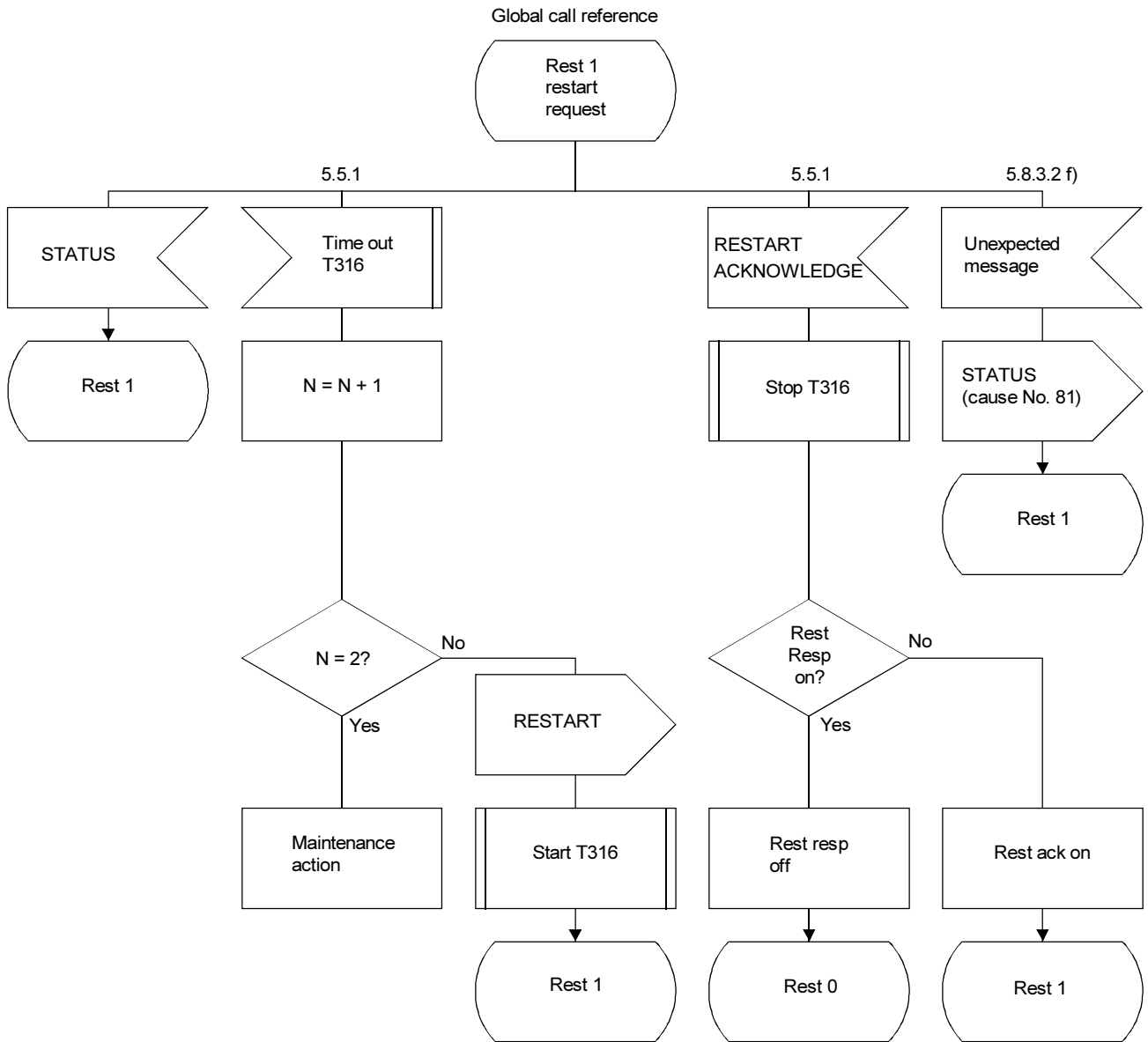

T1160940-94/d36

NOTE – T316 is optional (see 9.2).

FIGURE A.4/Q.931 (Sheet 2 of 4)
Detailed protocol control for the global call reference (user side)

Superseded by a more recent version

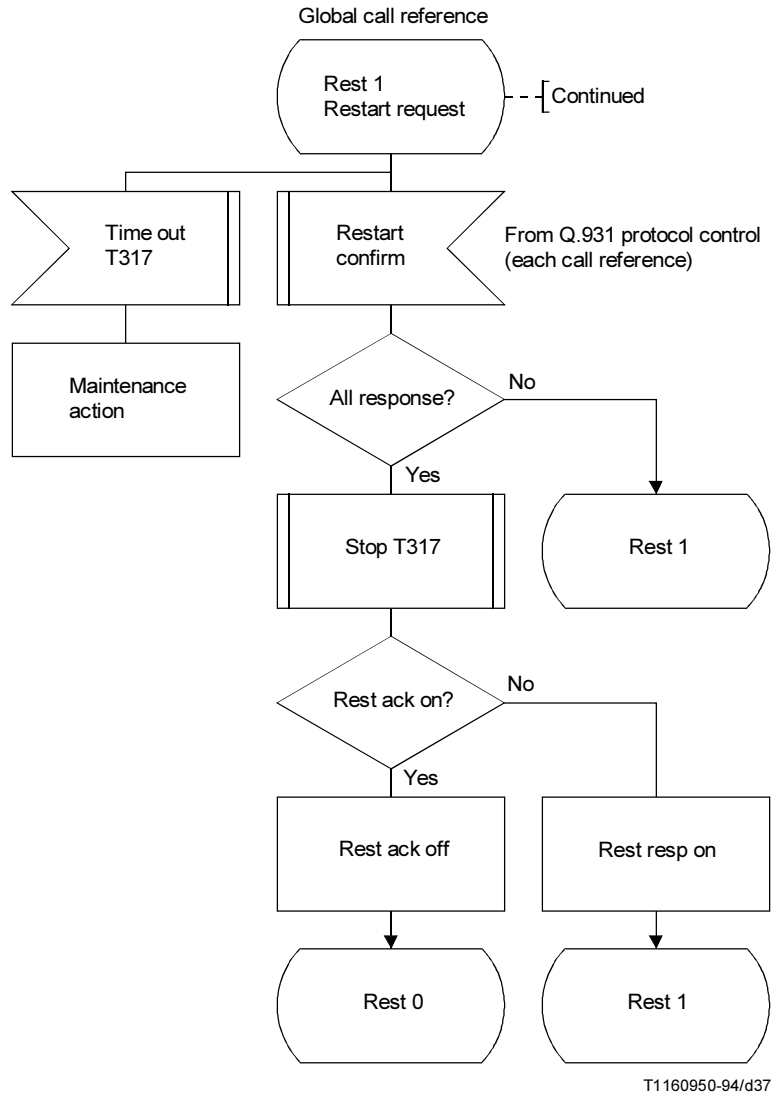

NOTE – T317 is optional (see 9.2).

FIGURE A.4/Q.931 (Sheet 3 of 4)
Detailed protocol control for the global call reference (user side)

Superseded by a more recent version

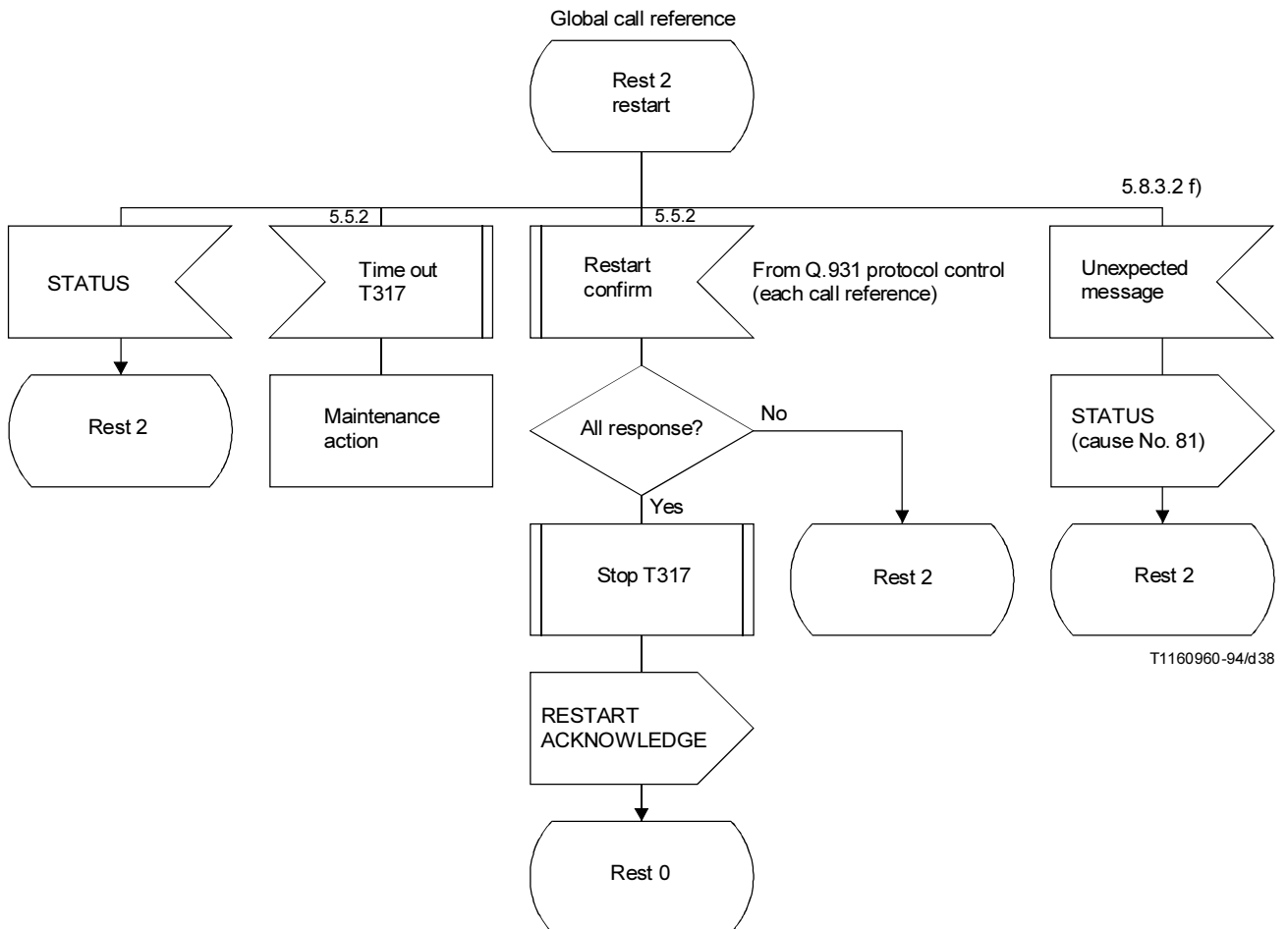

T1160960-94/d38

NOTE – T317 is optional (see 9.2).

FIGURE A.4/9.031 (Sheet 4 of 4)
Detailed protocol control for the global call reference (user side)

Superseded by a more recent version

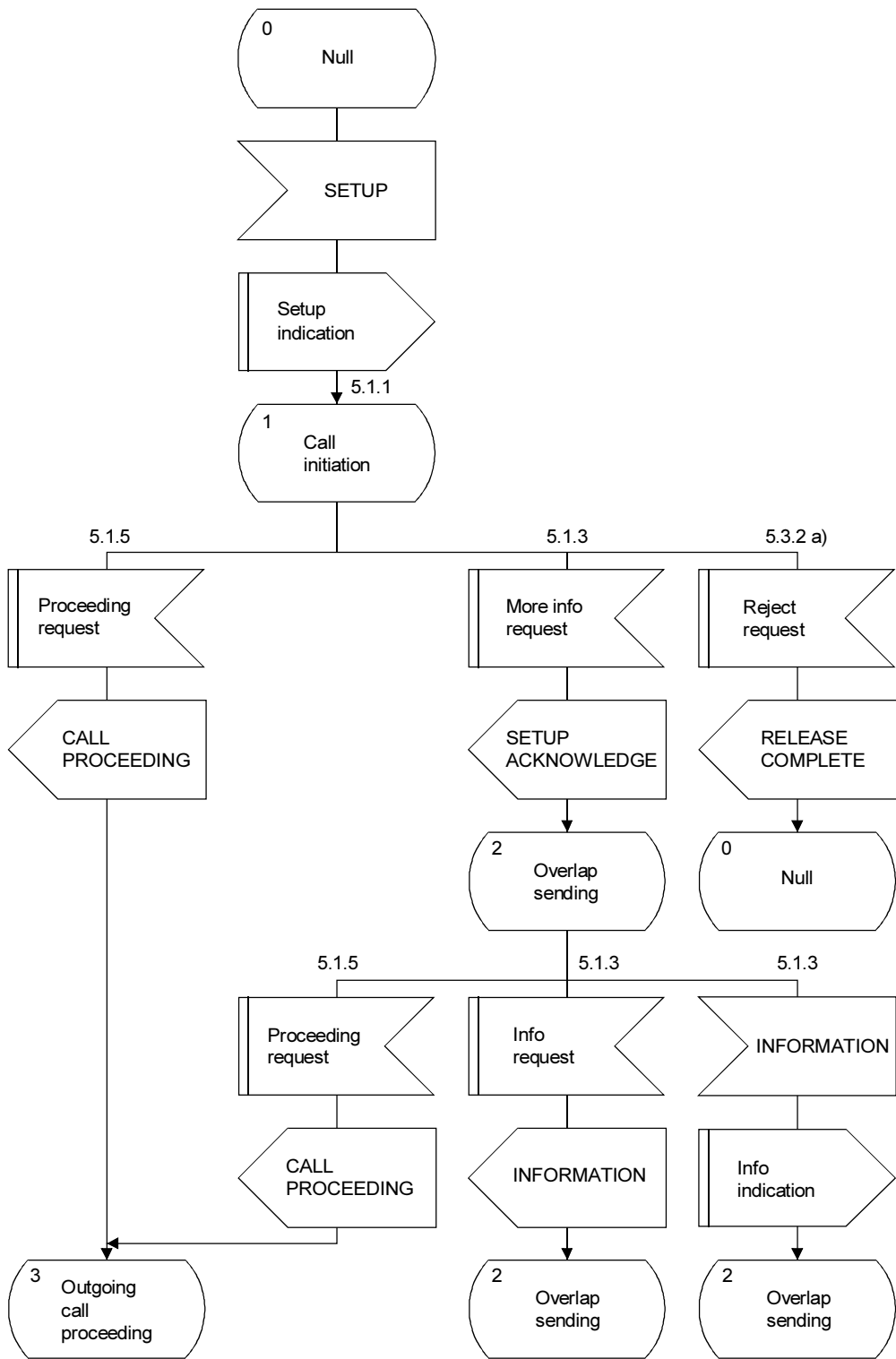

T1 160970-94/d39

a) Outgoing set-up procedure (1 of 2)

FIGURE A.5/Q.931 (Sheet 1 of 8)
Overview protocol control (network side) point-point

Superseded by a more recent version

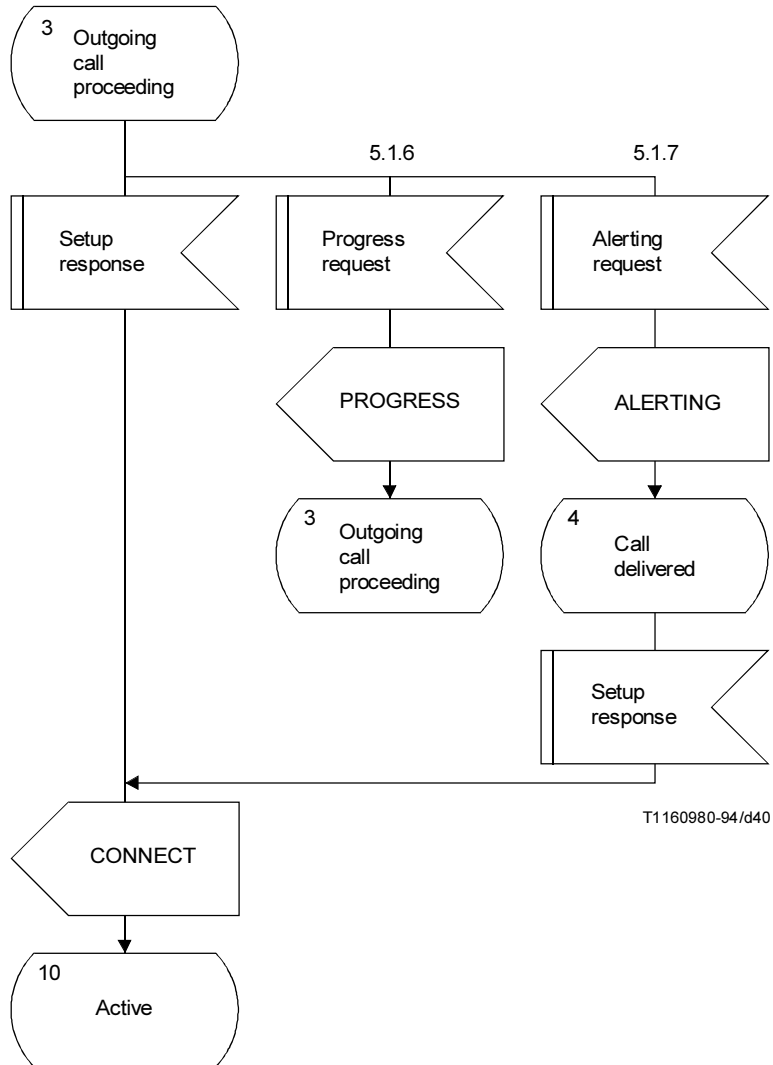

a) Outgoing set-up procedure (2 of 2)

FIGURE A.5/Q.931 (Sheet 2 of 8)
Overview protocol control (network side) point-point

Superseded by a more recent version

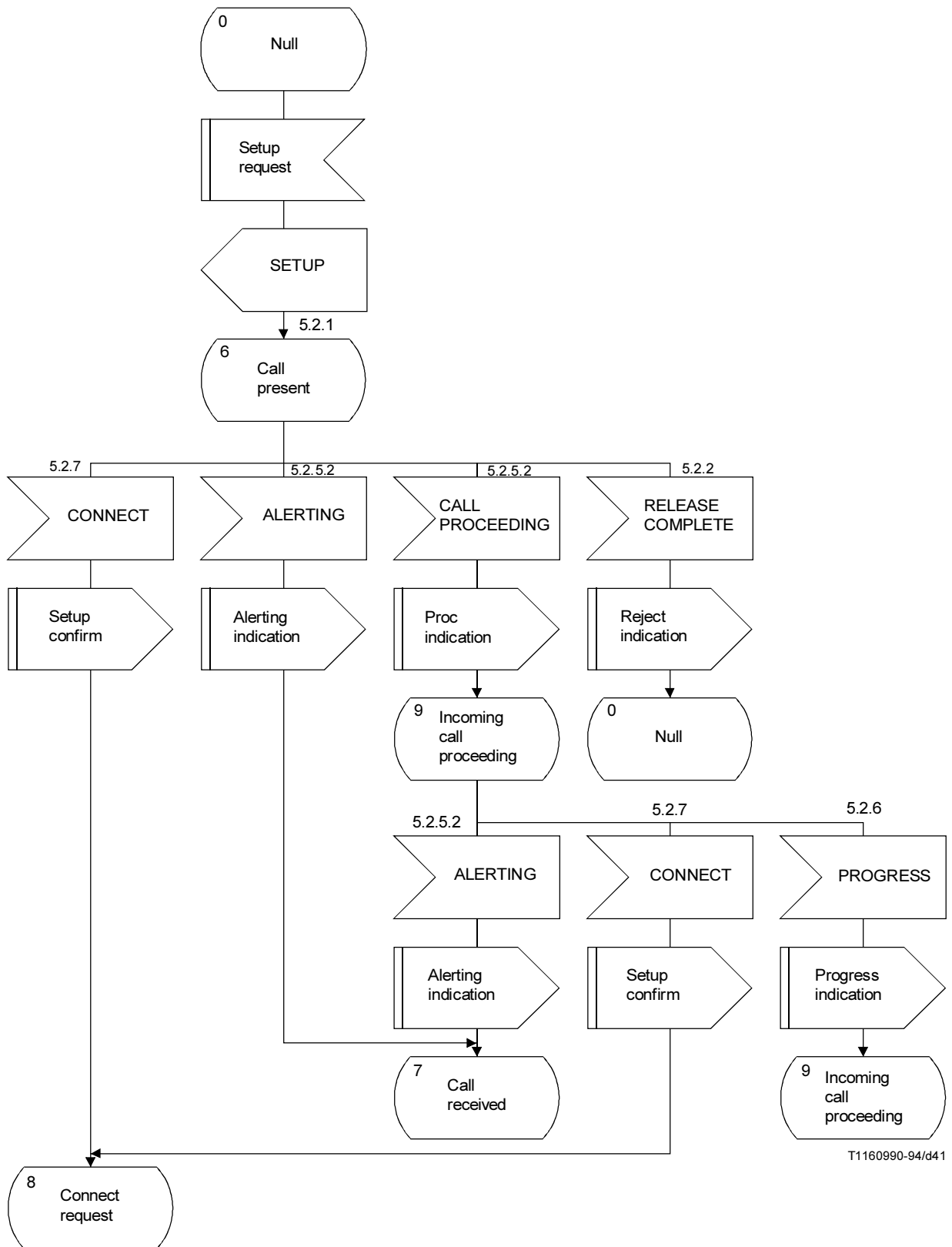

T1160990-94/d41

b) Incoming set-up procedure (1 of 2)

FIGURE A.5/Q.931 (Sheet 3 of 8)

Overview protocol control (network side) point-point

Superseded by a more recent version

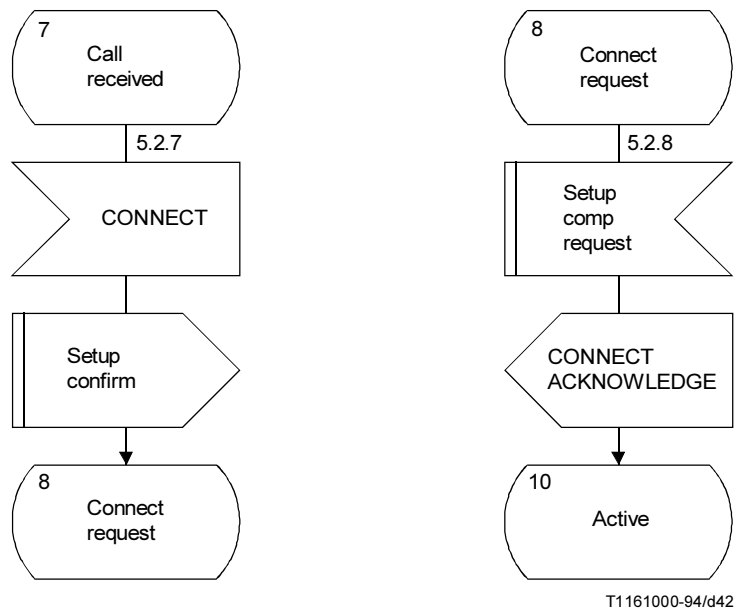

b) Incoming set-up procedure (2 of 2)

FIGURE A.5/Q.931 (Sheet 4 of 8)

Overview protocol control (network side) point-point

Superseded by a more recent version

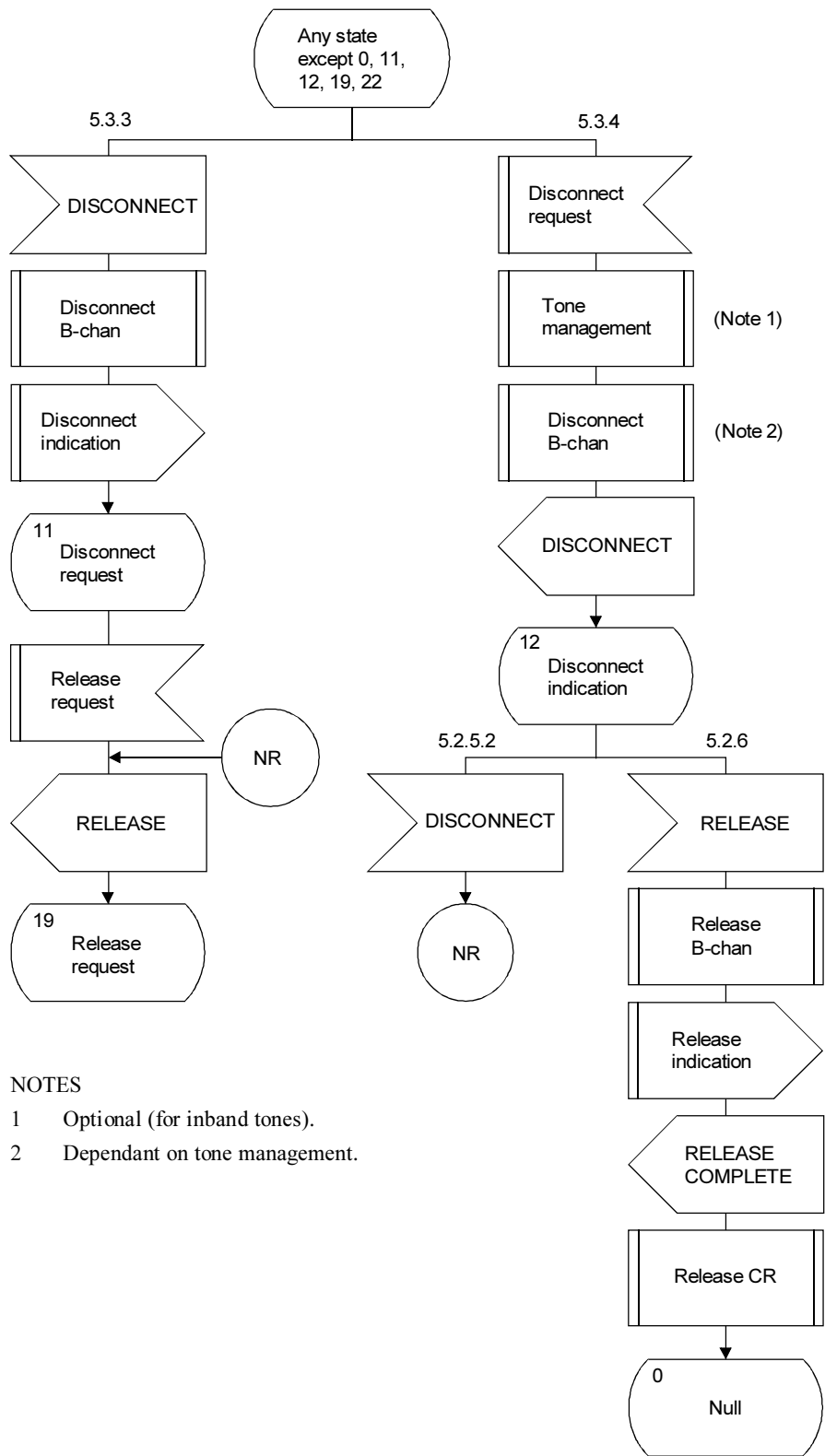

NOTES

- 1 Optional (for inband tones).
- 2 Dependant on tone management.

T1161010-94/d43

c) Clearing procedure (1 of 2)

FIGURE A.5/Q.931 (Sheet 5 of 8)
Overview protocol control (network side) point-point

Superseded by a more recent version

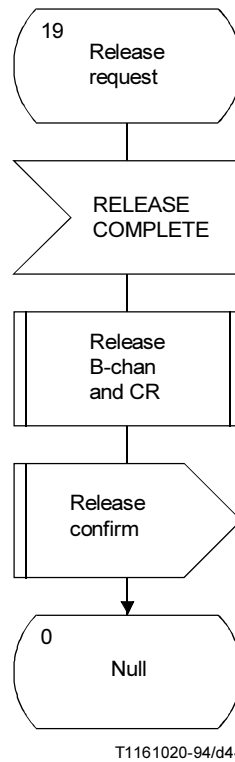

c) Clearing procedure (2 of 2)

FIGURE A.5/Q.931 (Sheet 6 of 8)
Overview protocol control (network side) point-point

Superseded by a more recent version

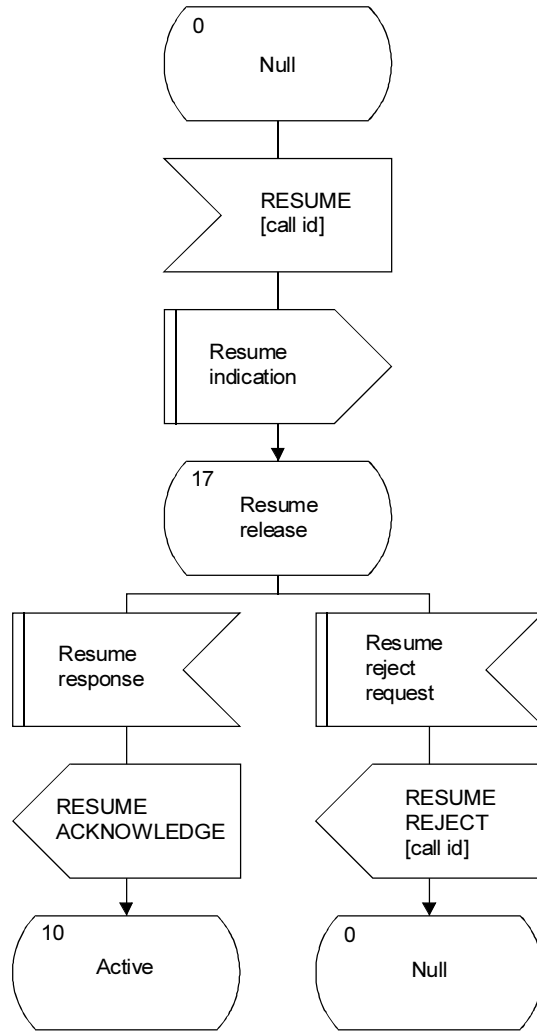

T1161030-94/d45

d) Resume procedure

FIGURE A.5/Q.931 (Sheet 7 of 8)

Overview protocol control (network side) point-point

Superseded by a more recent version

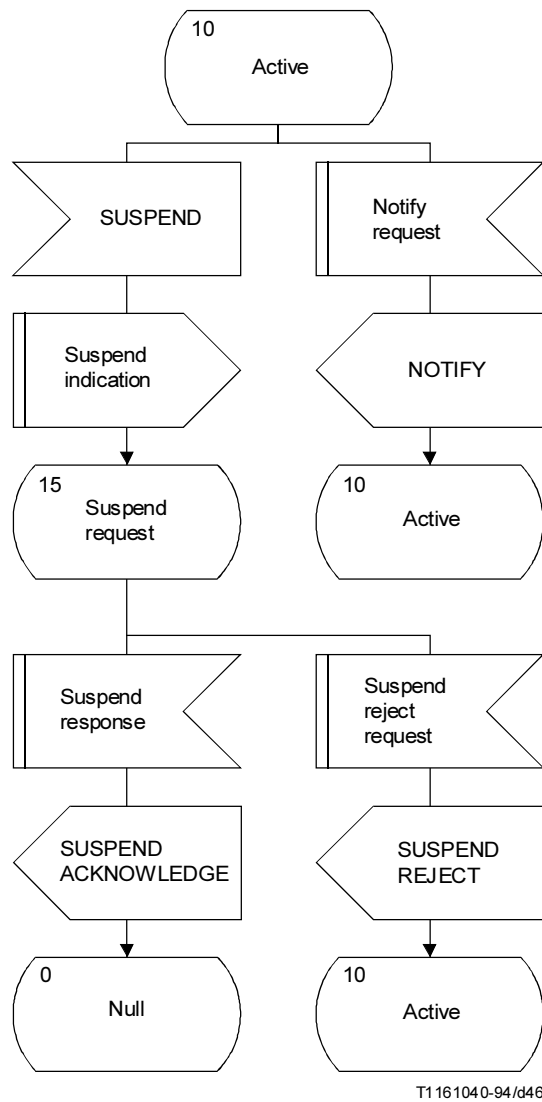

e) Suspend procedure

FIGURE A.5/Q.931 (Sheet 8 of 8)

Overview protocol control (network side) point-point

Superseded by a more recent version

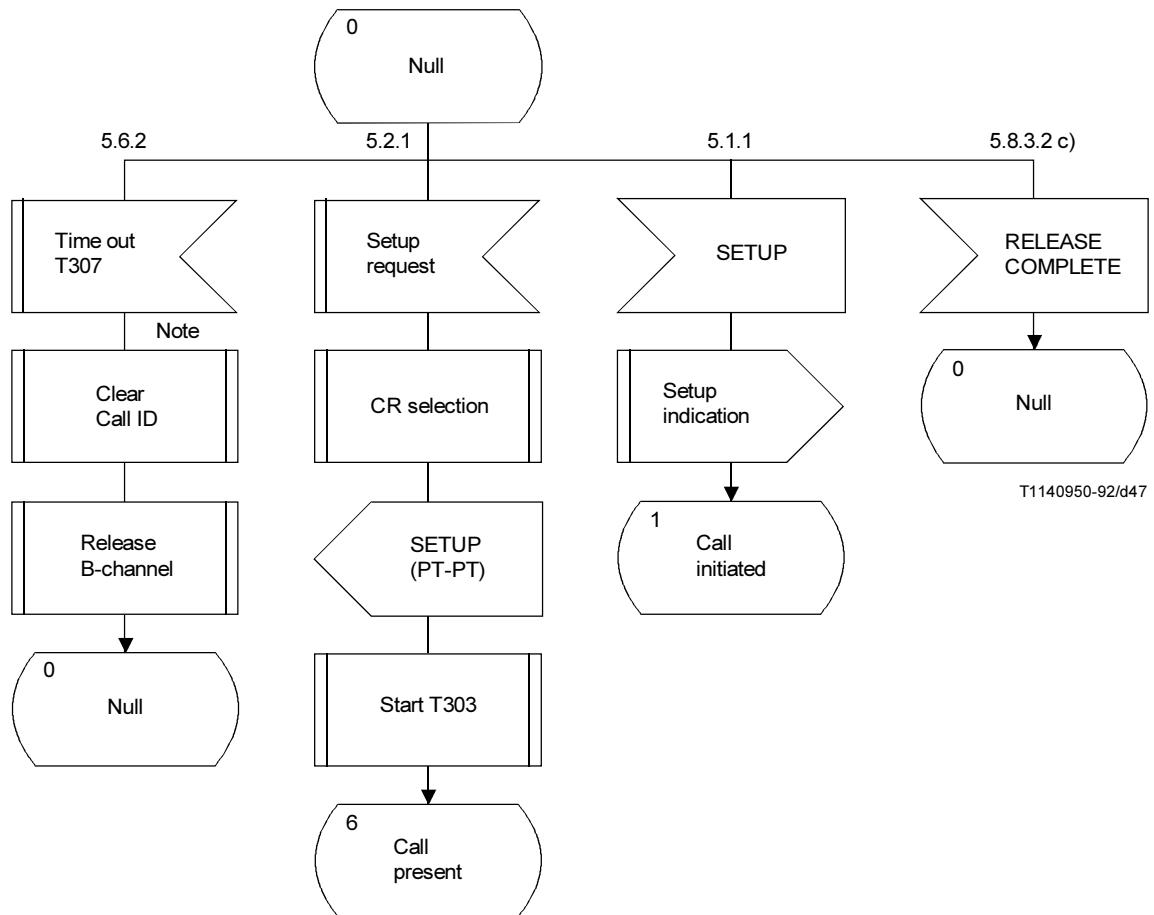

NOTE – No call reference is associated with T307.

FIGURE A.6/Q.931 (Sheet 1 of 27)
Detailed protocol control (network side) point-point

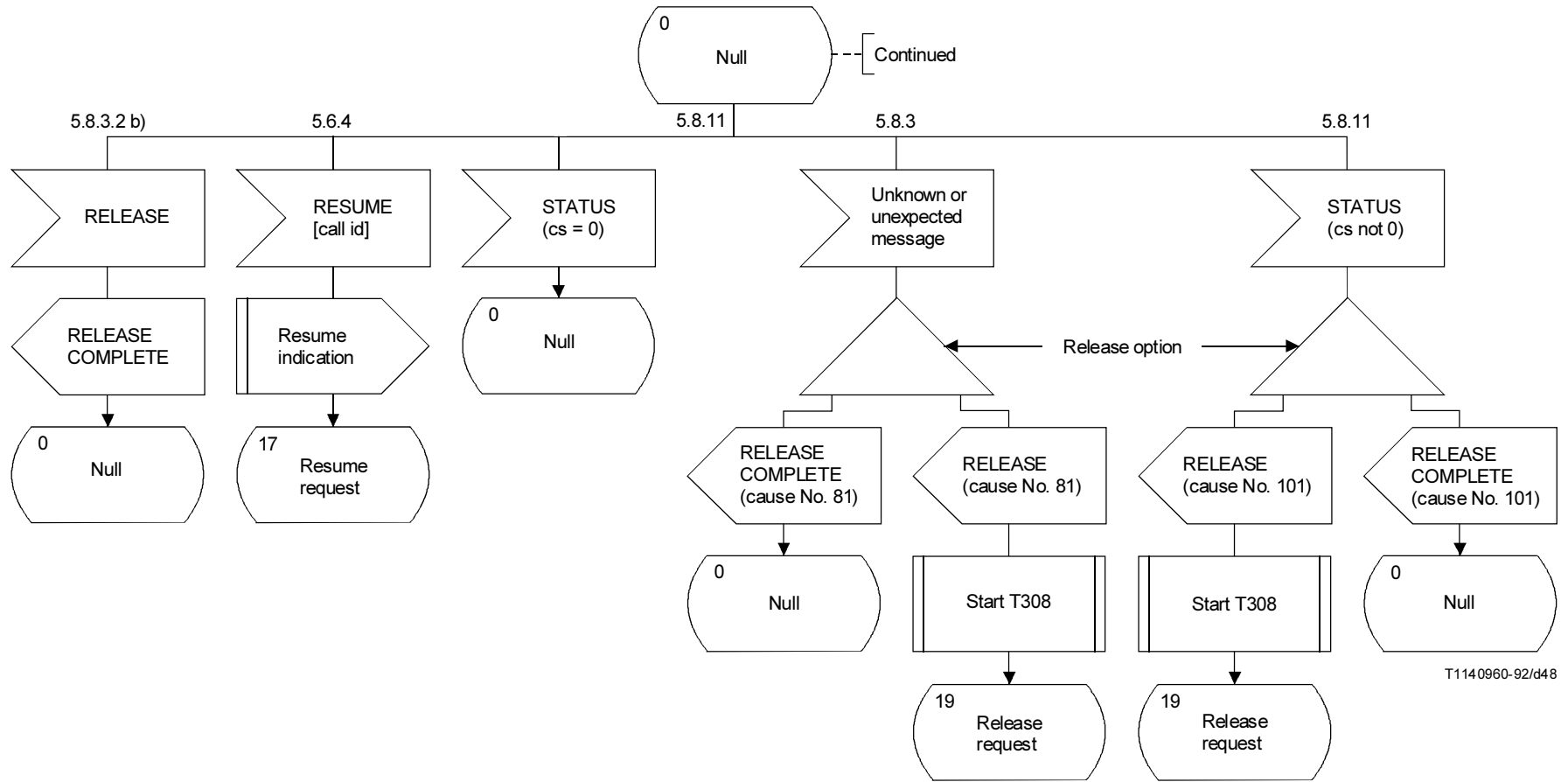

FIGURE A.6/Q.931 (Sheet 2 of 27)
Detailed protocol control (network side) point-point

Superseded by a more recent version

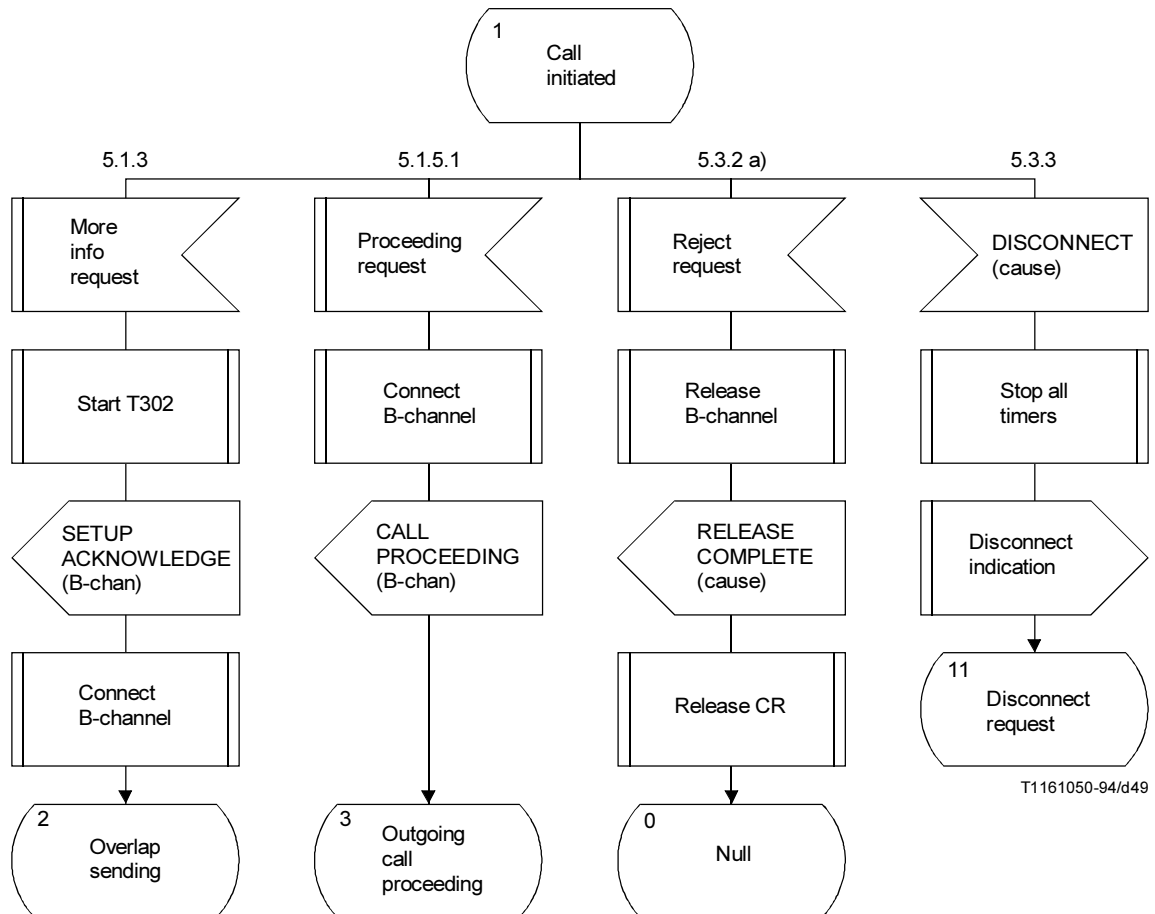
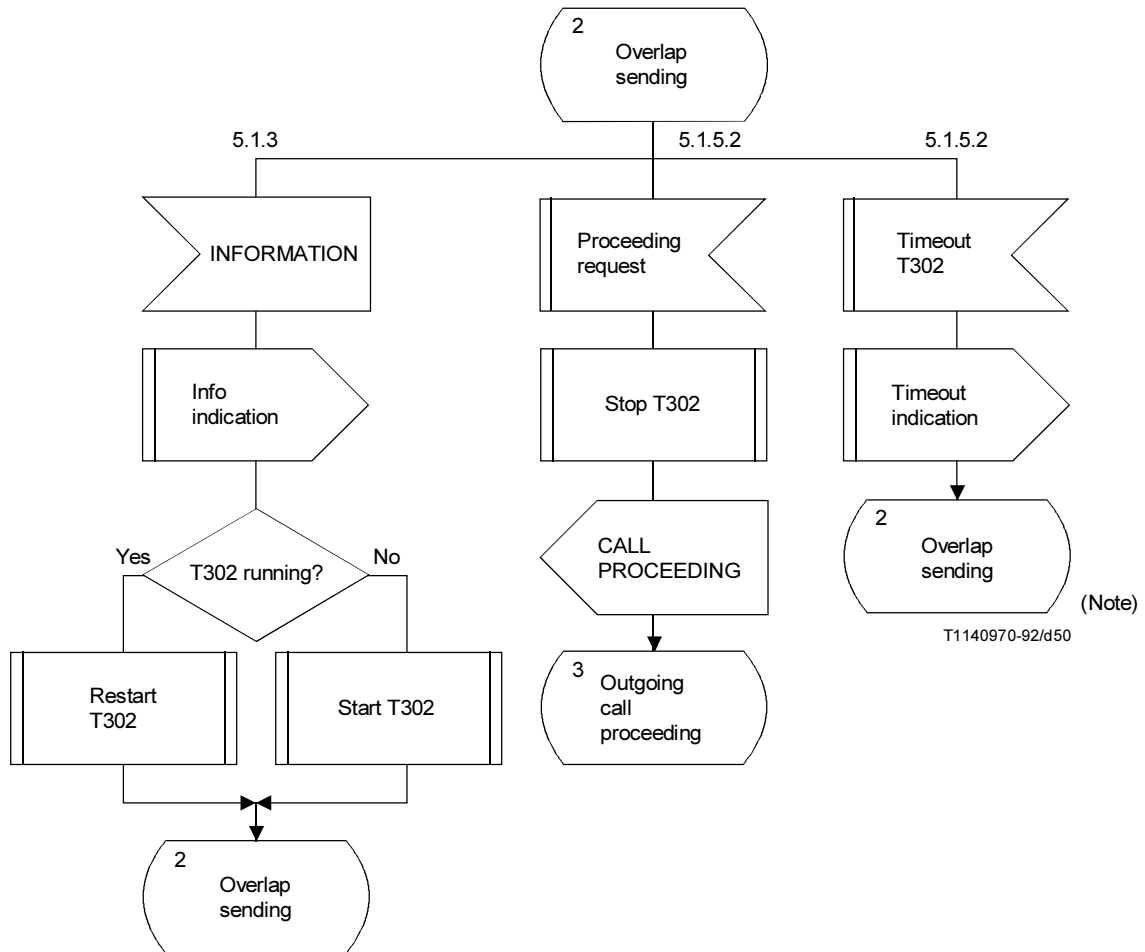

FIGURE A.6/Q.931 (Sheet 3 of 27)
Detailed protocol control (network side) point-point

Superseded by a more recent version



NOTE – It is assumed that the CC functional block will carry out the functions of 5.1.5.2 and 5.1.7.

FIGURE A.6/Q.931 (Sheet 4 of 27)
Detailed protocol control (network side) point-point

Superseded by a more recent version

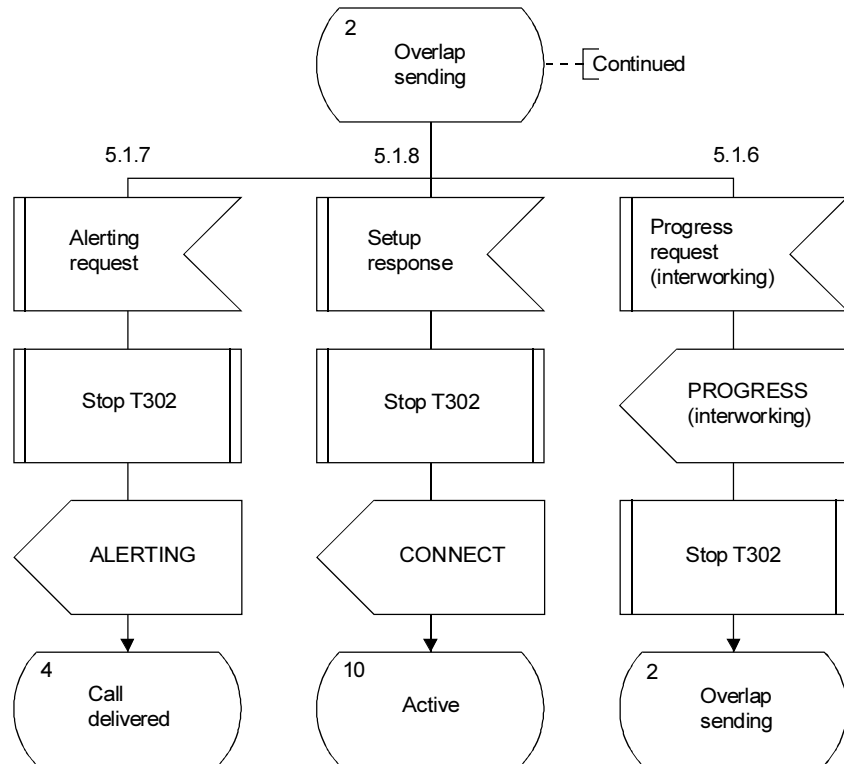

T116 1060-94/d51

FIGURE A.6/Q.931 (Sheet 5 of 27)
Detailed protocol control (network side) point-point

Superseded by a more recent version

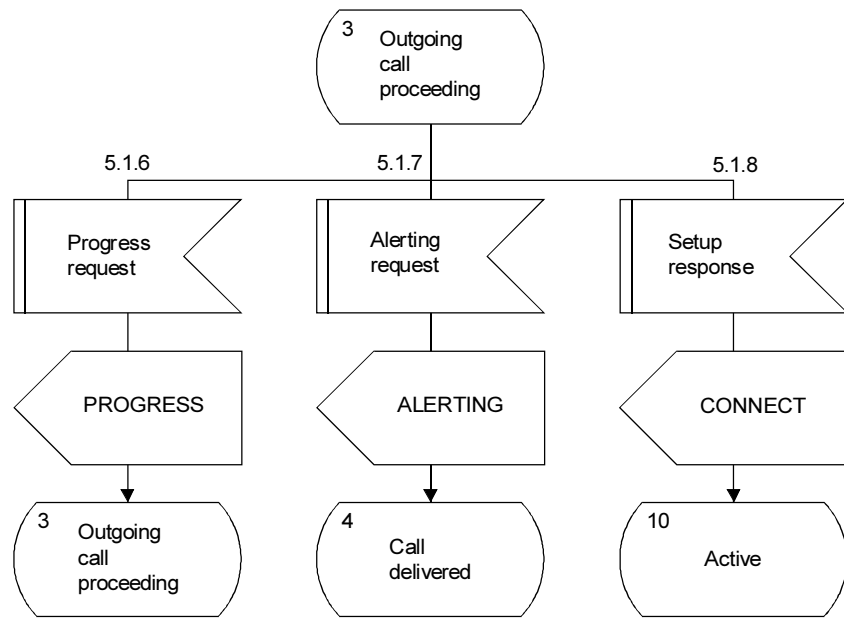

T1161070-94/d52

FIGURE A.6/Q.931 (Sheet 6 of 27)
Detailed protocol control (network side) point-point

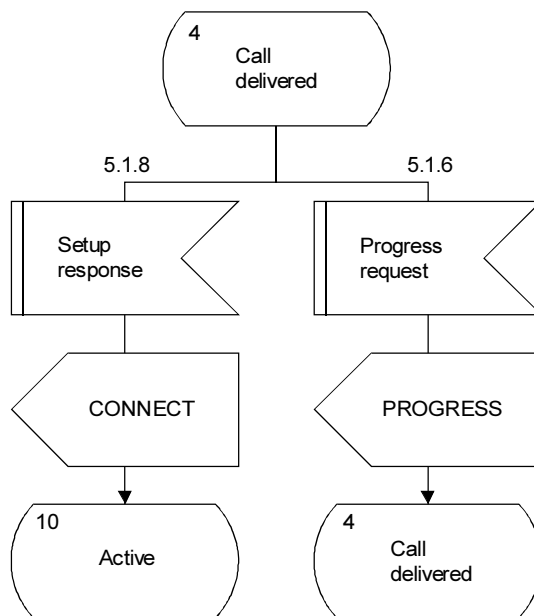

T1161080-94/d53

FIGURE A.6/Q.931 (Sheet 7 of 27)
Detailed protocol control (network side) point-point

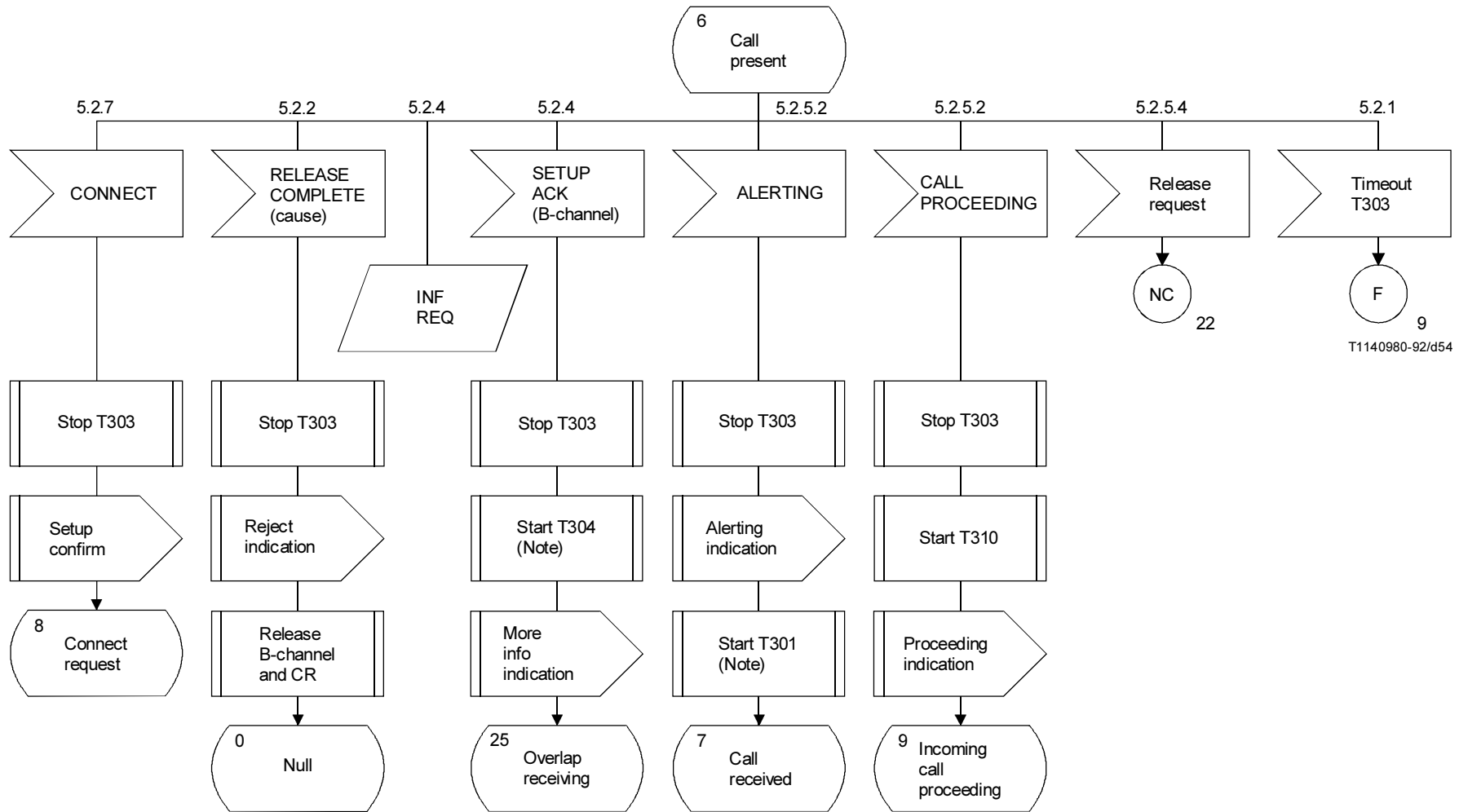

NOTE – T301 and T304 are optional (see 9.1).

FIGURE A.6/Q.931 (Sheet 8 of 27)
Detailed protocol control (network side) point-point

Superseded by a more recent version

Superseded by a more recent version

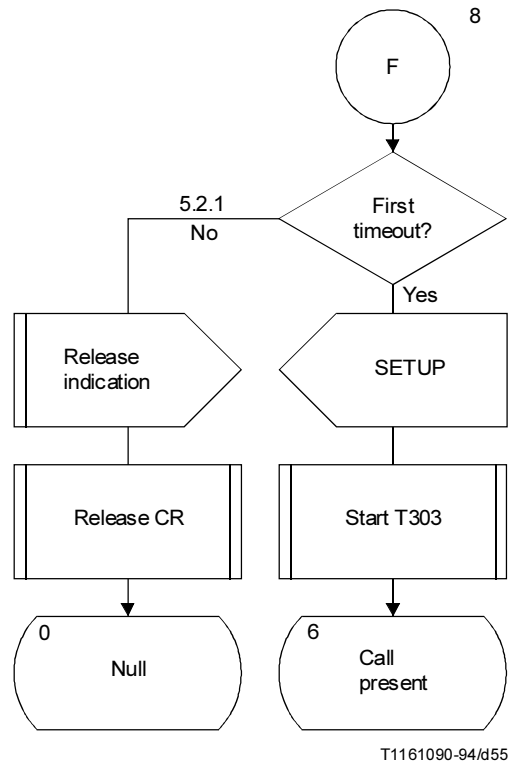
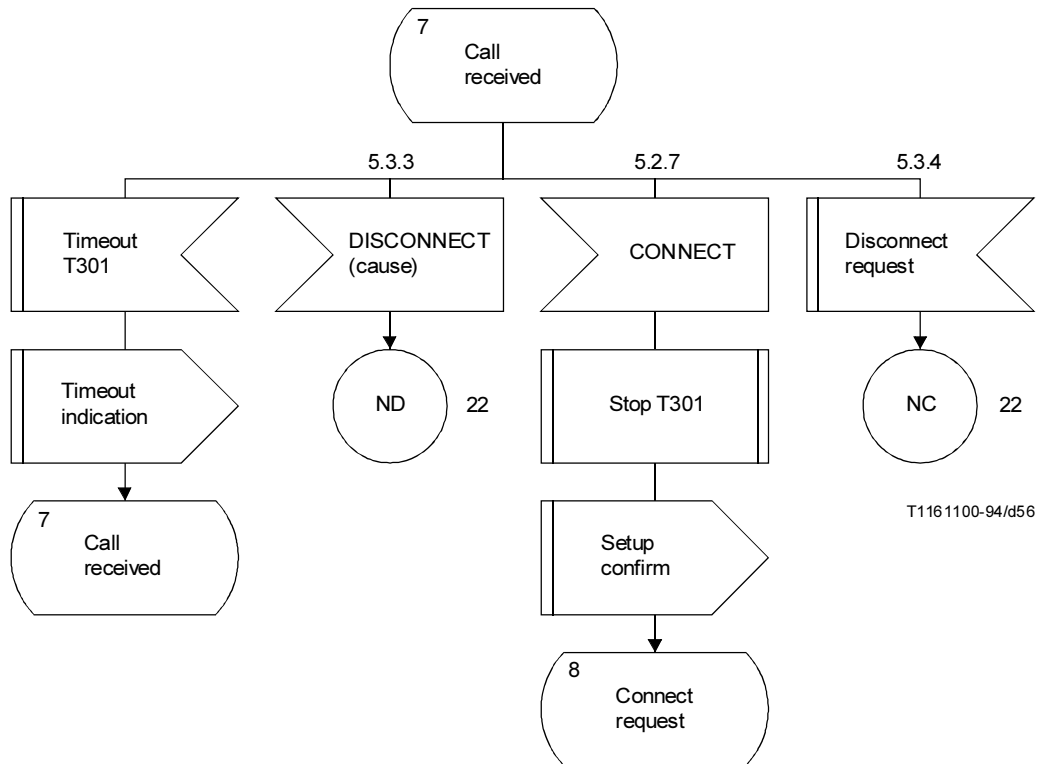

FIGURE A.6/Q.931 (Sheet 9 of 27)
Detailed protocol control (network side) point-point

Superseded by a more recent version



NOTE – T301 is optional (see 9.1).

FIGURE A.6/Q.931 (Sheet 10 of 27)
Detailed protocol control (network side) point-point

Superseded by a more recent version

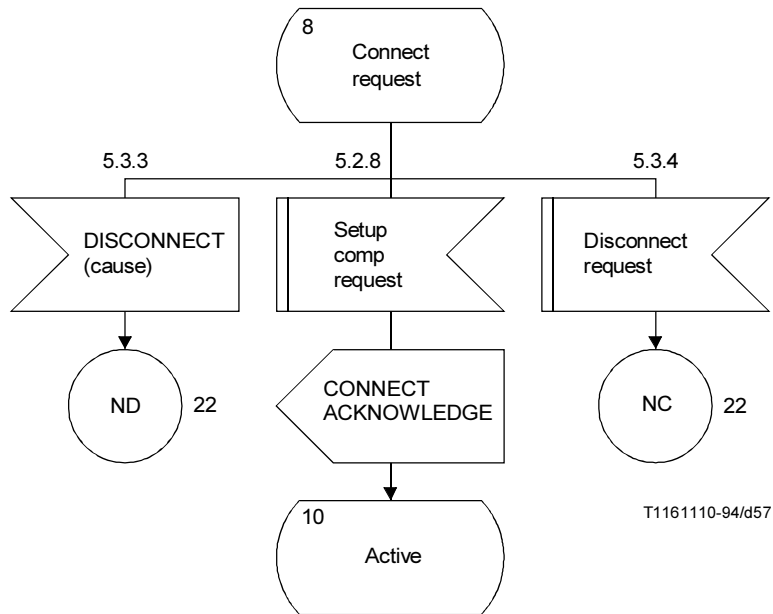
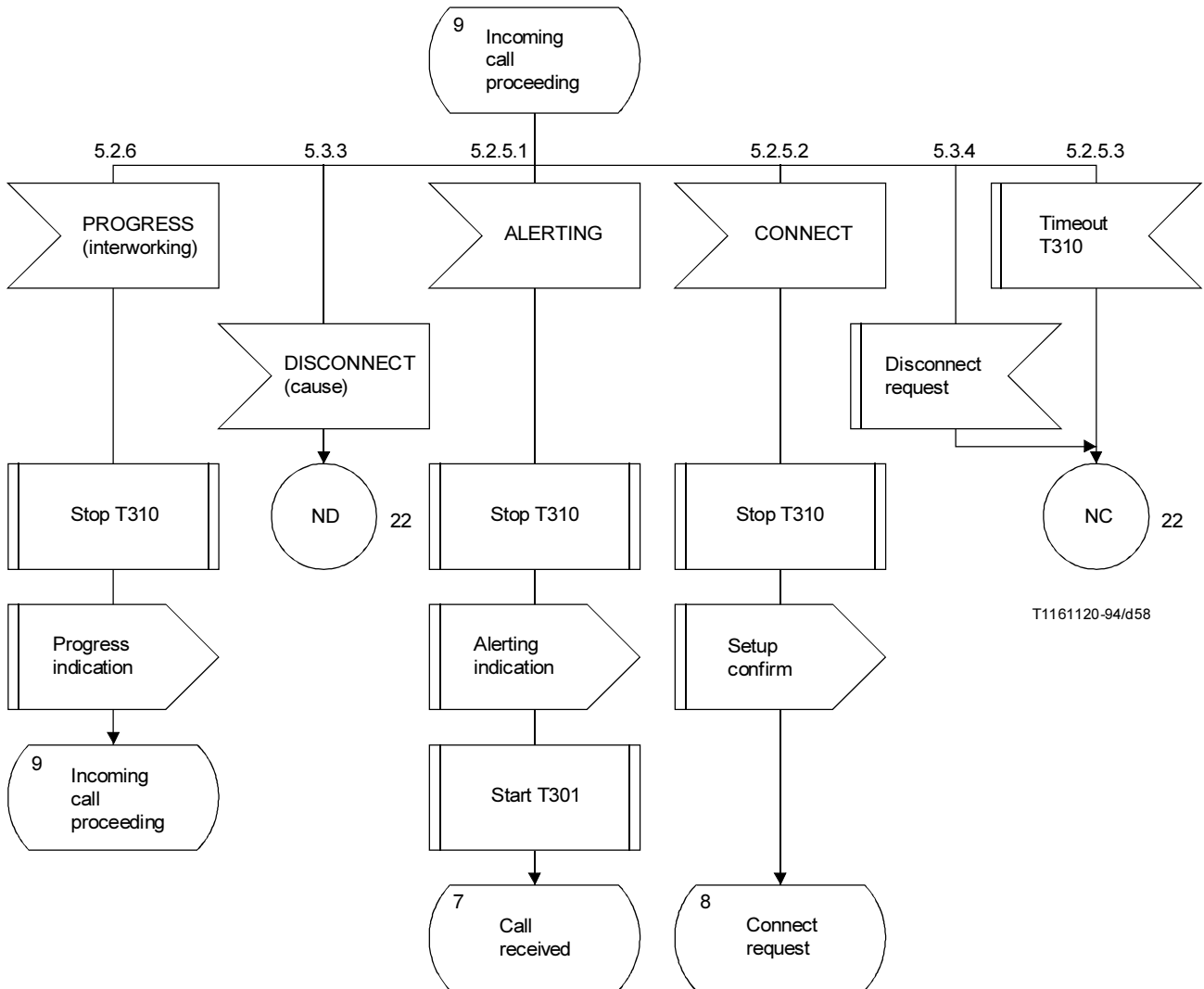

FIGURE A.6/Q.931 (Sheet 11 of 27)

Detailed protocol control (network side) point-point

Superseded by a more recent version



NOTE – T301 is optional (see 9.1).

FIGURE A.6/Q.931 (Sheet 12 of 27)
Detailed protocol control (network side) point-point

Superseded by a more recent version

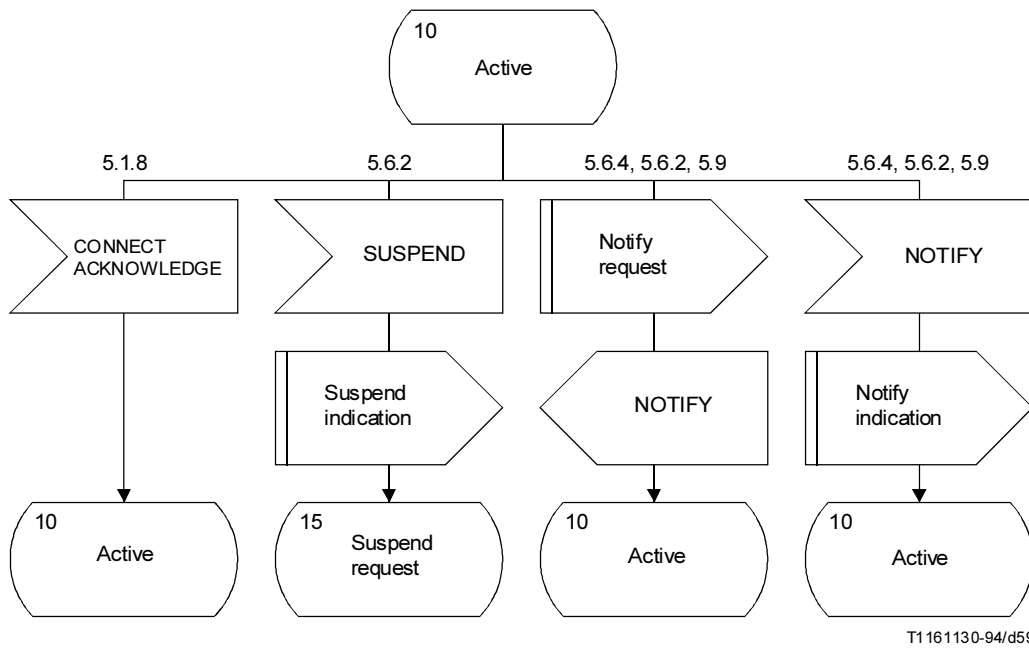

FIGURE A.6/Q.931 (Sheet 13 of 27)
Detailed protocol control (network side) point-point

Superseded by a more recent version

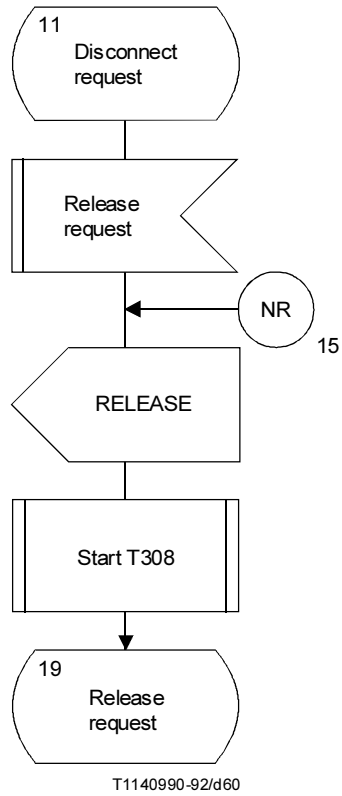

FIGURE A.6/Q.931 (Sheet 14 of 27)
Detailed protocol control (network side) point-point

Superseded by a more recent version

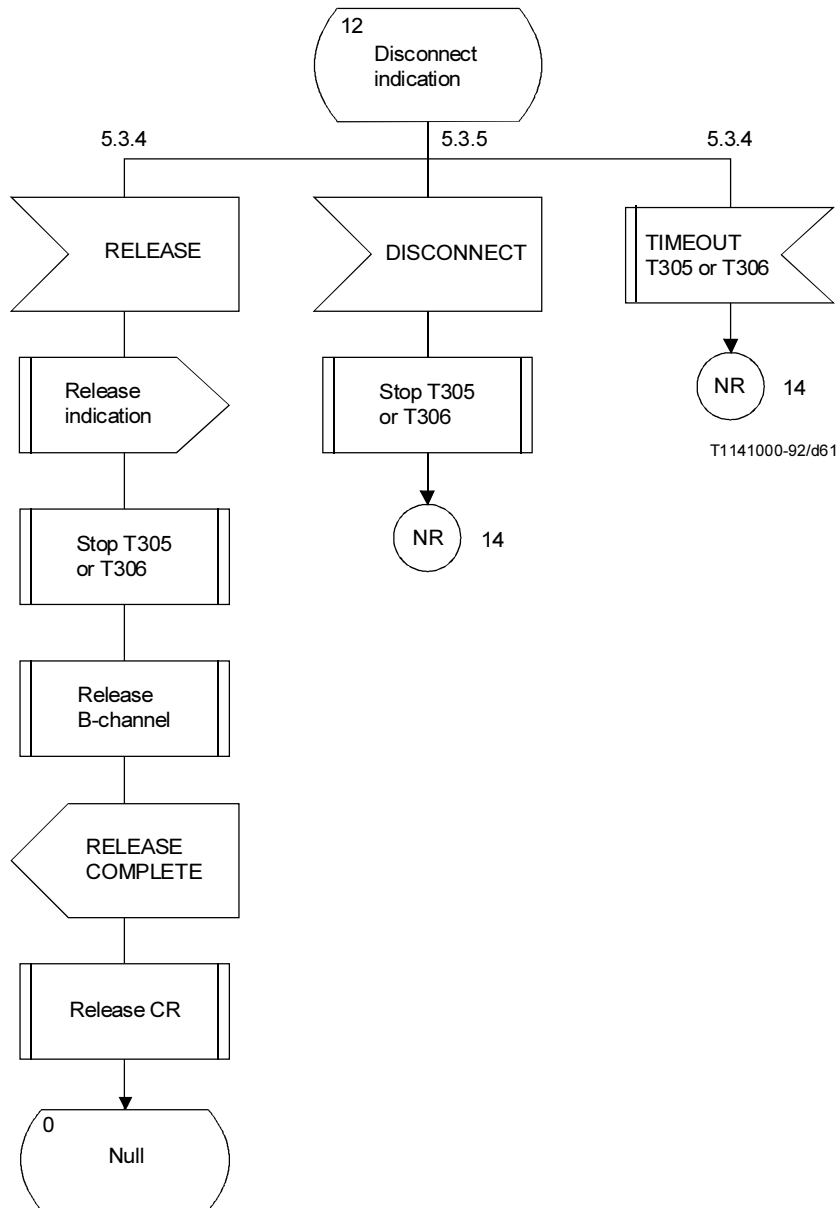

FIGURE A.6/Q.931 (Sheet 15 of 27)

Detailed protocol control (network side) point-point

Superseded by a more recent version

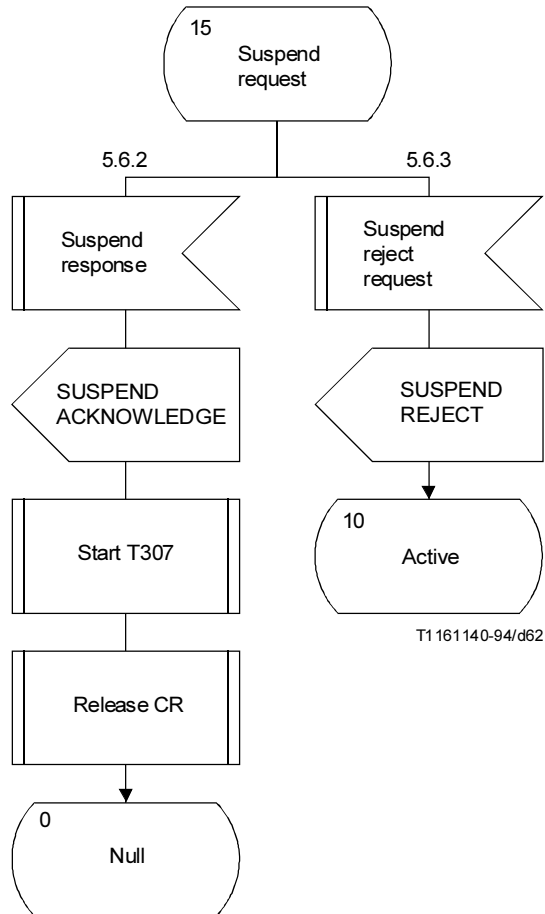

FIGURE A.6/Q.931 (Sheet 16 of 27)
Detailed protocol control (network side) point-point

Superseded by a more recent version

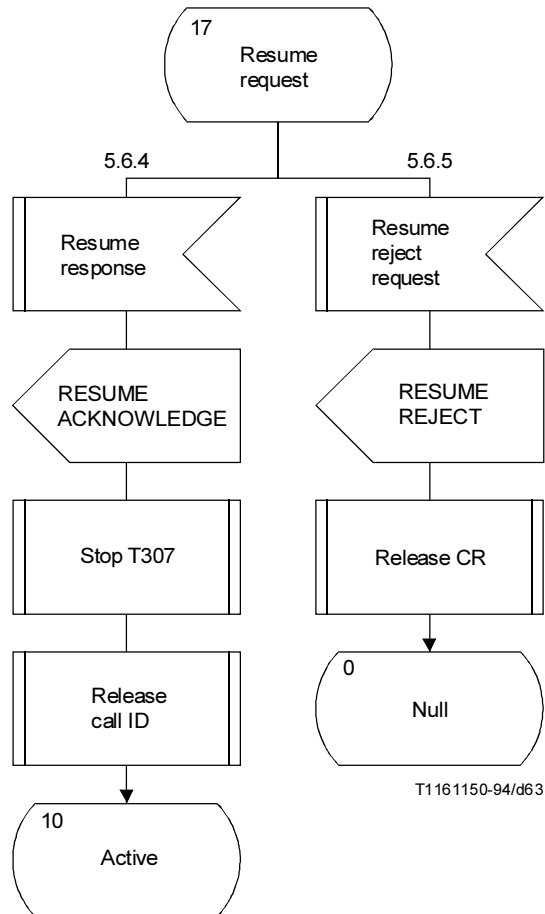
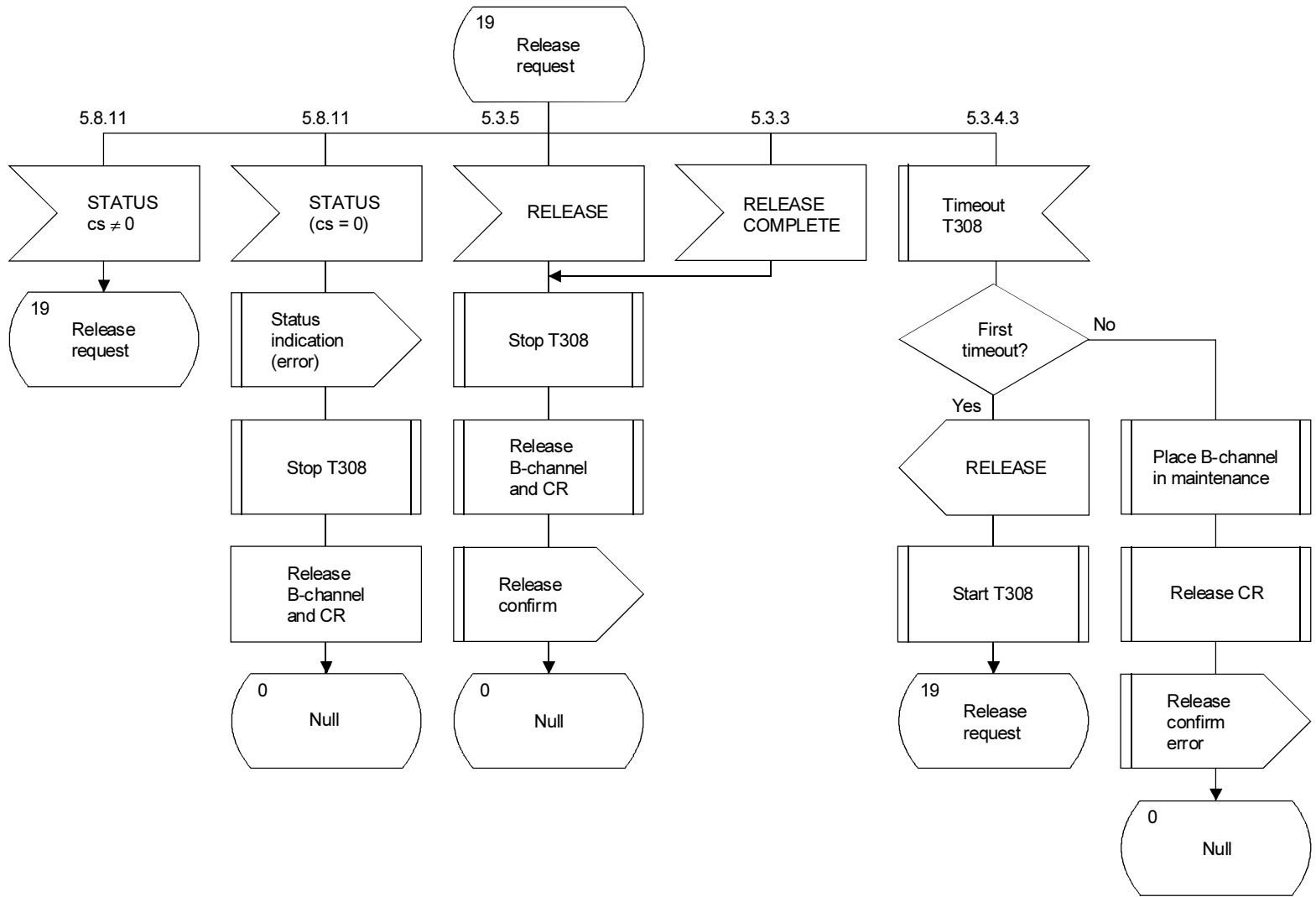

FIGURE A.6/Q.931 (Sheet 17 of 27)
Detailed protocol control (network side) point-point



T114.1020-92/d64

FIGURE A.6/Q.931 (Sheet 18 of 27)
Detailed protocol control (network side) point-point

Superseded by a more recent version

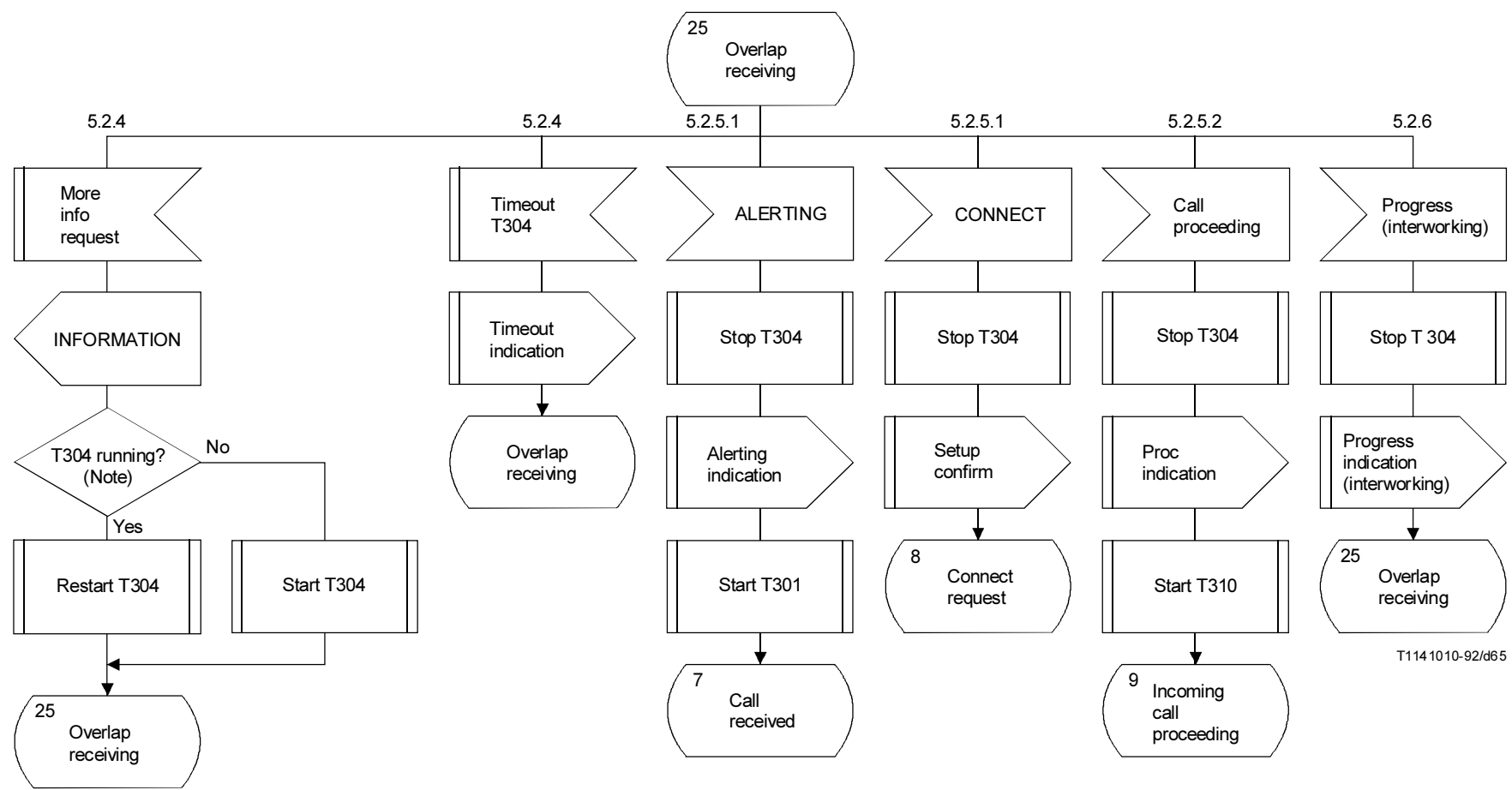

NOTE – T304 is optional (see 9.1).

FIGURE A.6/Q.931 (Sheet 19 of 27)
Detailed protocol control (network side) point-point

Superseded by a more recent version

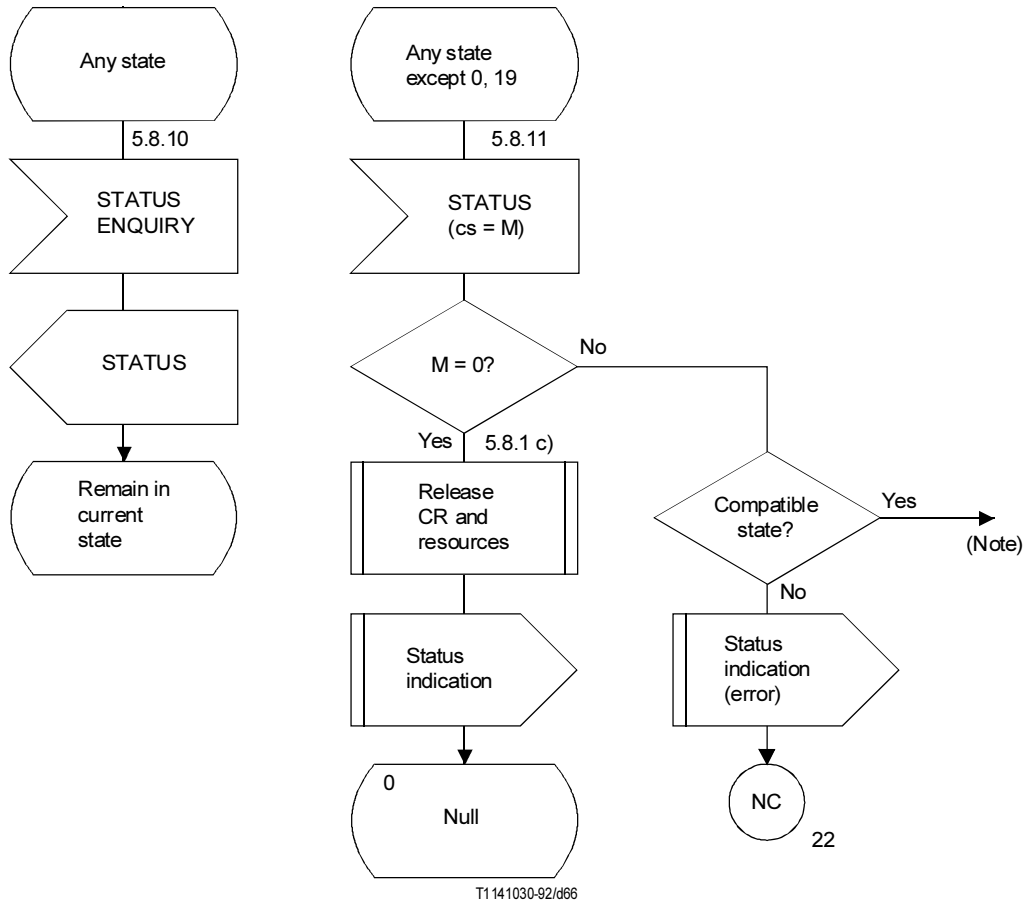

NOTE – Action on receipt of STATUS indicating a compatible call state is implementation dependent. (See 5.8.11).

FIGURE A.6/Q.931 (Sheet 20 of 27)
Detailed protocol control (network side) point-point

Superseded by a more recent version

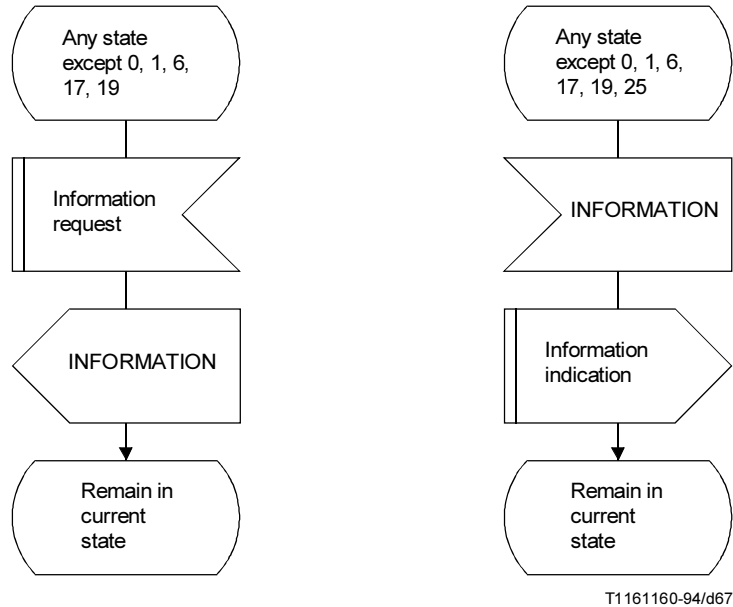
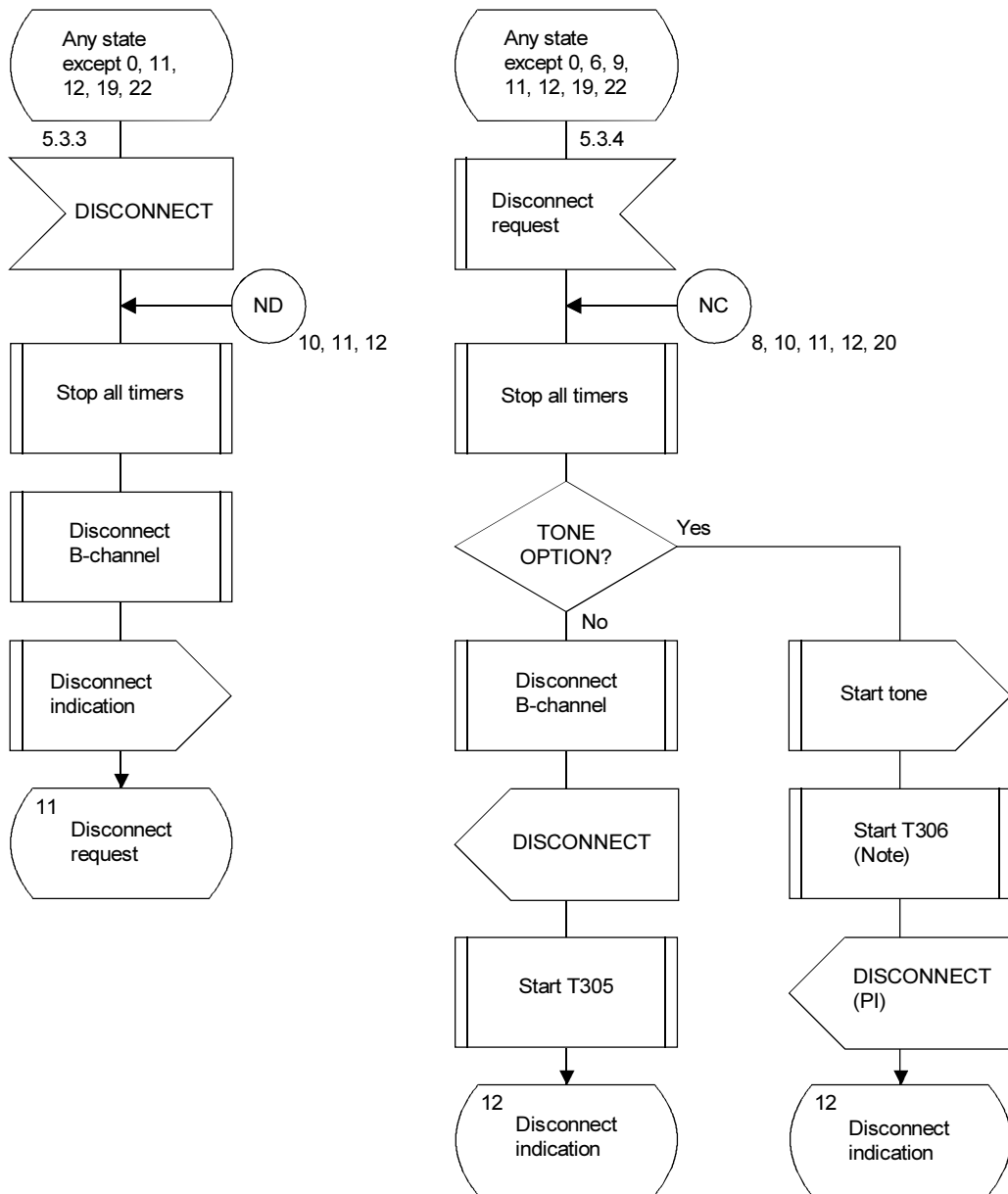

FIGURE A.6/Q.931 (Sheet 21 of 27)
Detailed protocol control (network side) point-point

Superseded by a more recent version



T1141040-92/d68

NOTE – See 9.1 for default values of T306.

FIGURE A.6/Q.931 (Sheet 22 of 27)
Detailed protocol control (network side) point-point

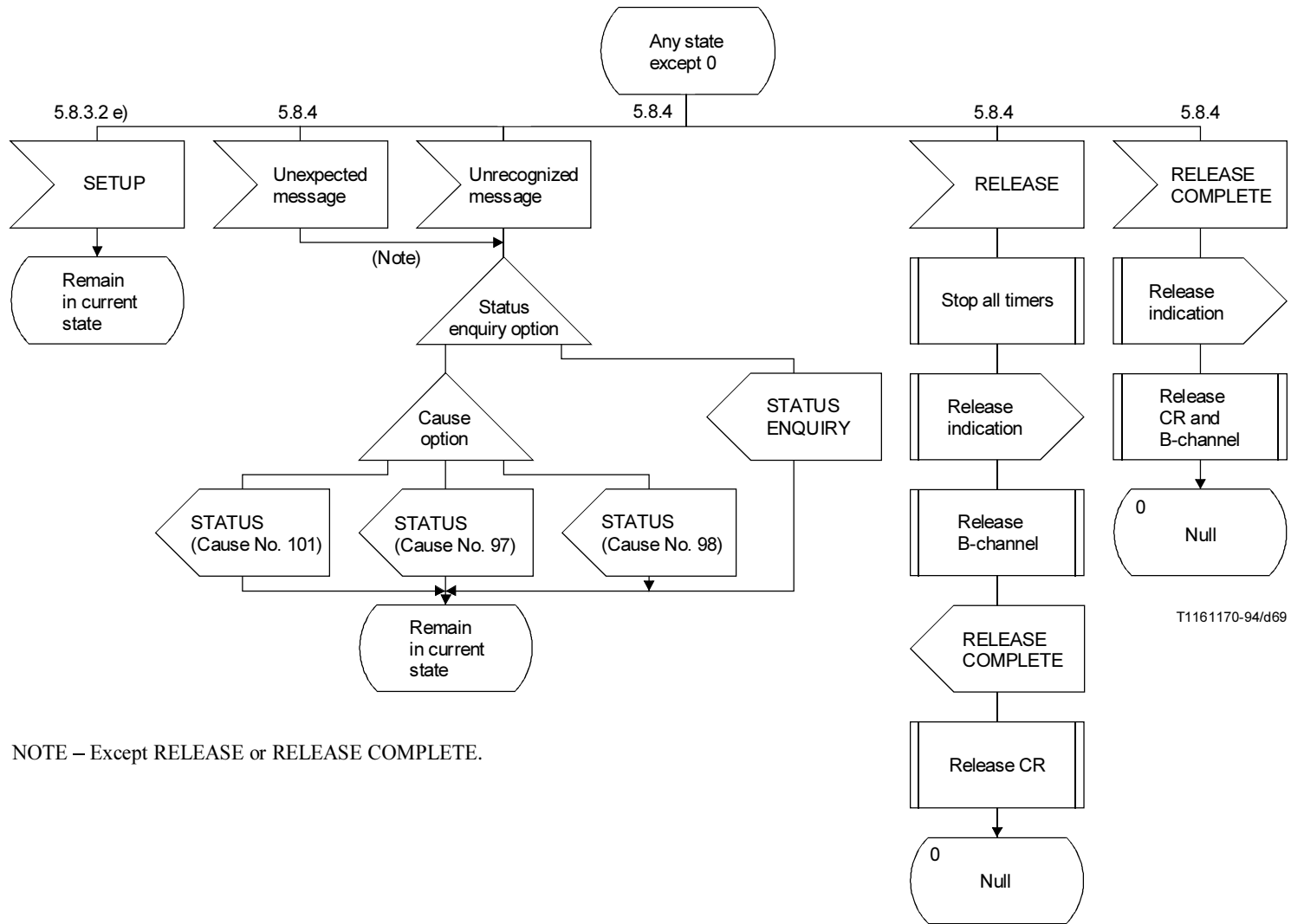

NOTE – Except RELEASE or RELEASE COMPLETE.

a) Error handling SDL diagram (1 of 2)

FIGURE A.6/Q.931 (Sheet 23 of 27)
Detailed protocol control (network side) point-point

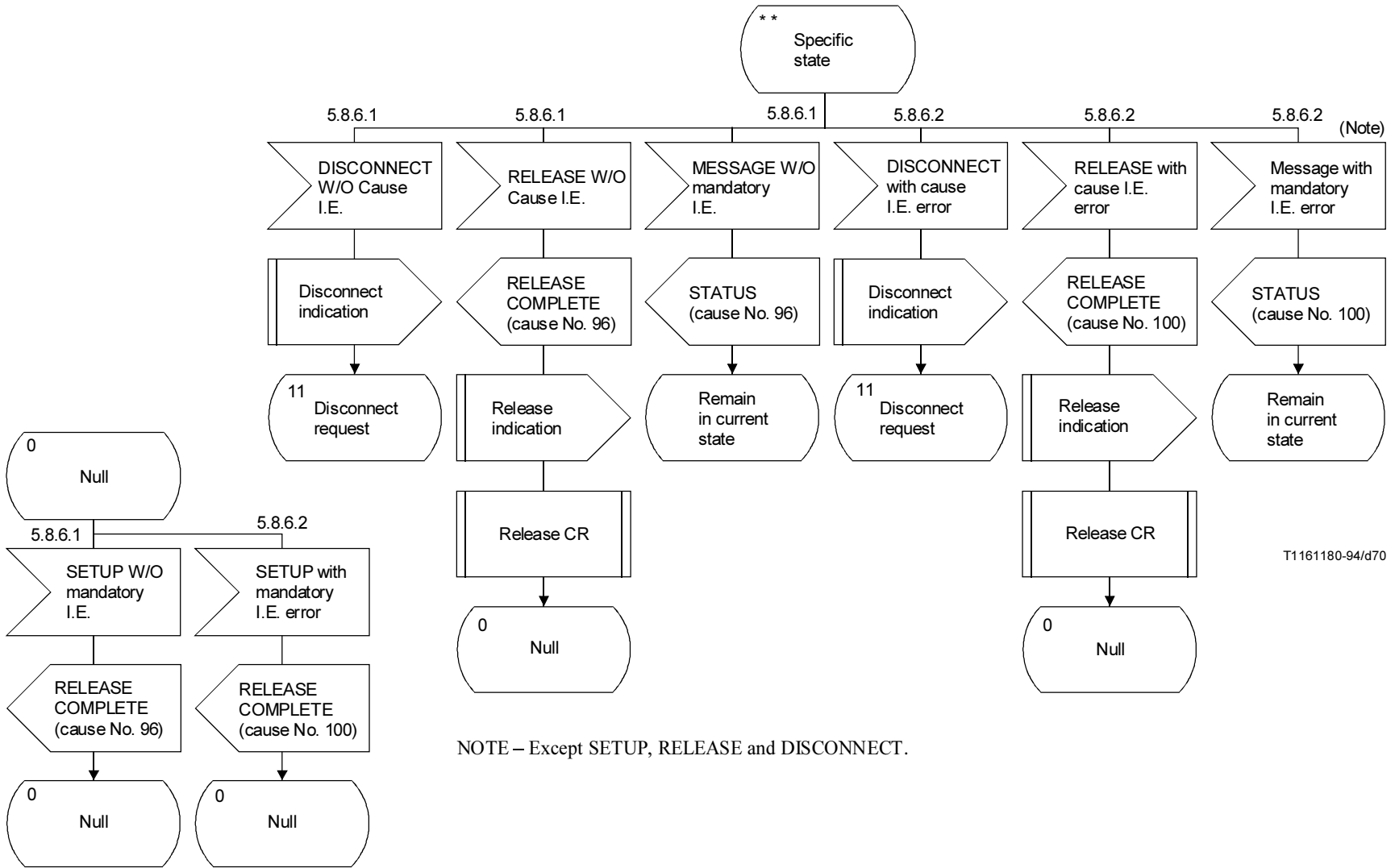

a) Error handling SDL diagram (2 of 2)

FIGURE A.6/Q.931 (Sheet 24 of 27)
Detailed protocol control (network side) point-point

Superseded by a more recent version

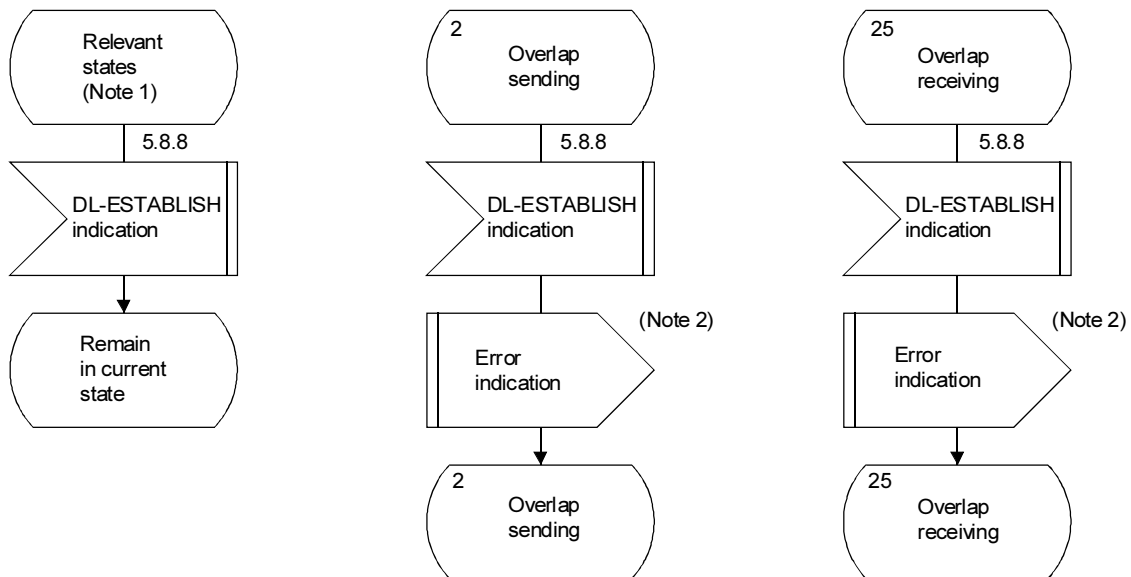

T1161190-94/d71

NOTES

- 1 The relevant states are as follows: N1, N3, N6 to N12, N15, N17, N19.
- 2 At the reception of this primitive, the call control should clear the call by sending disconnect request primitives.

FIGURE A.6/Q.931 (Sheet 25 of 27)
Detailed protocol control (network side) point-point

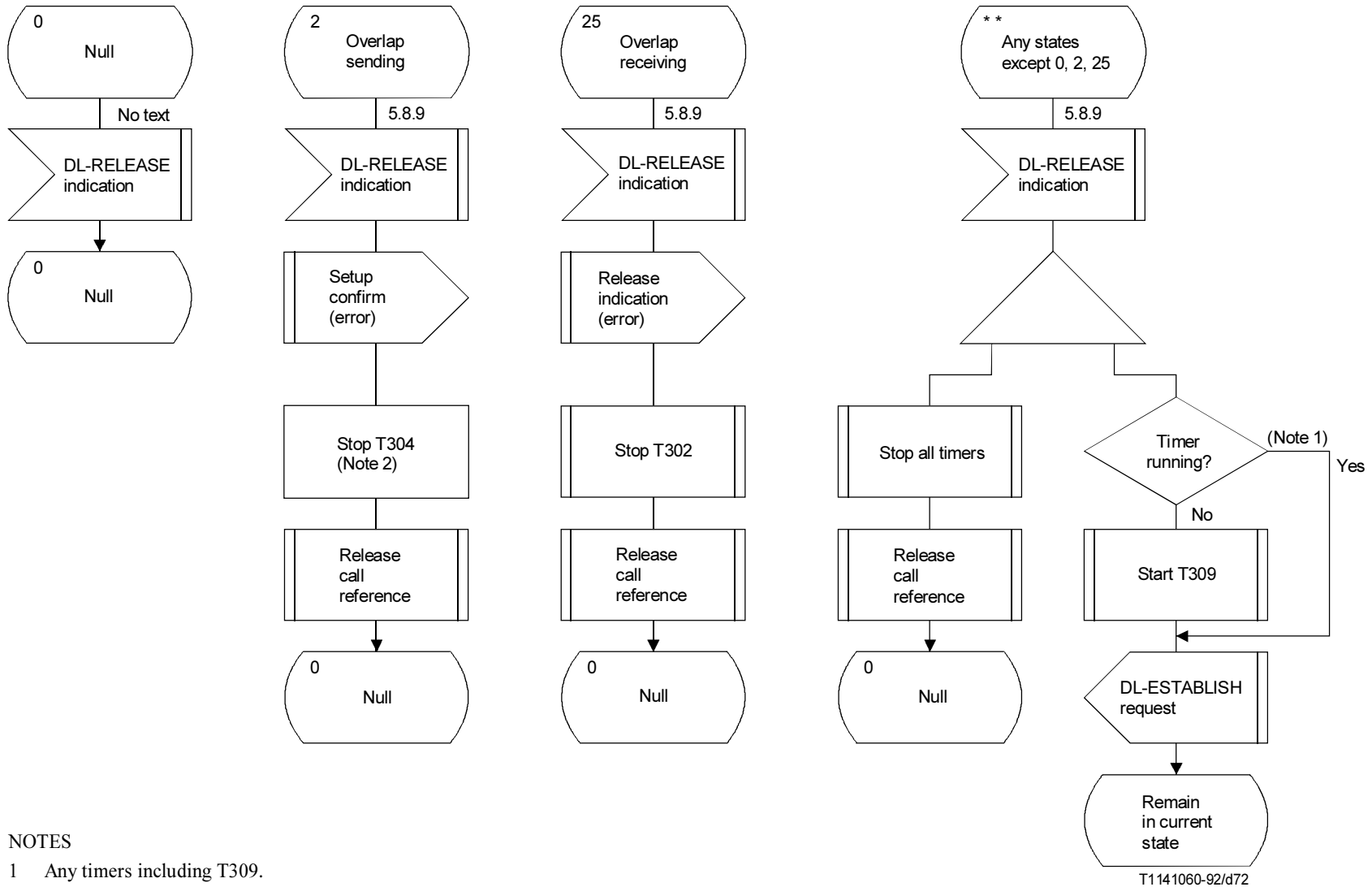

Superseded by a more recent version

FIGURE A.6/Q.931 (Sheet 26 of 27)
Detailed protocol control (network side) point-point

Superseded by a more recent version

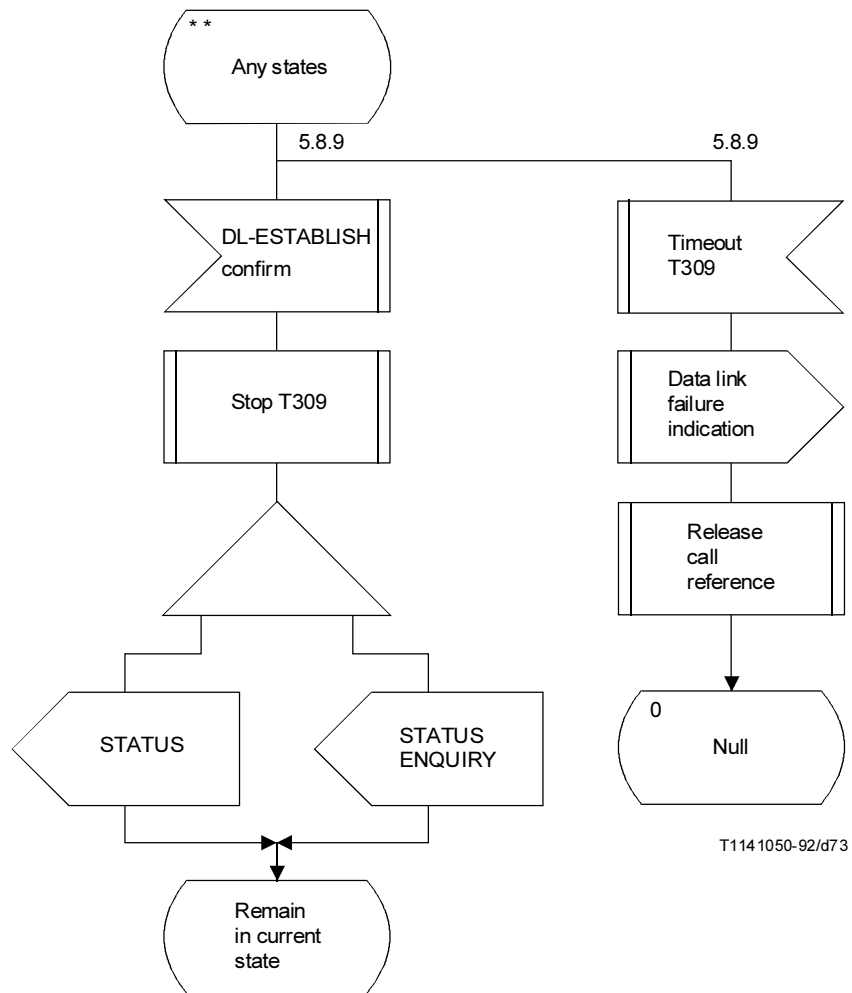

FIGURE A.6/A.931 (Sheet 27 of 27)

Detailed protocol control (network side) point-point

Superseded by a more recent version

Annex B Compatibility and address checking

(This annex forms an integral part of this Recommendation)

B.1 Introduction

This annex describes the various compatibility and address checks which should be carried out to ensure that best match of user and network capabilities is achieved on a call within an ISDN.

This annex also covers interworking with existing networks.

Three different processes of checking shall be performed:

- i) at the user-to-network interface on the calling side (see B.2);
- ii) at the network-to-user interface on the called side (see B.3.2); and
- iii) user-to-user (see B.3.3).

NOTE – In this context and throughout this annex the term “called user” is the endpoint entity which is explicitly addressed. This may be an addressed interworking unit (IWU); see the I.500-Series Recommendations.

For details on the coding of the information required for compatibility checking see Annex I.

B.2 Calling side compatibility checking

At the calling side, the network shall check that the bearer service requested by the calling user in the Bearer capability information element matches with the bearer services provided to that user by the network. If a mismatch is detected, then the network shall reject the call using one of the causes listed in 5.1.5.2.

Network services are described in Recommendations I.230 [47] and I.240 [48] as bearer services and teleservices, respectively.

B.3 Called side compatibility and address checking

In this subclause, the word “check” means that the user examines the contents of the specified information element.

B.3.1 Checking of addressing information

If an incoming SETUP message is offered with addressing information (i.e. either DDI or sub-addressing or the appropriate part of the called party number), the following actions will occur:

- a) If a number or sub-address is assigned to a user, then the information in a Called party number or Called party subaddress information element of the incoming call shall be checked by the user against the corresponding part of the number assigned to the user or the user’s own sub-address. In case of a mismatch, the user shall ignore the call. In the case of match, the compatibility checking described in B.3.2 through B.3.3 will follow.
- b) If a user has no assigned number or sub-address, then the Called party number and Called party subaddress information element shall be ignored. Then, compatibility checking described in B.3.2 and B.3.3 will follow.

NOTES

1 According to user’s requirements, compatibility checking can be performed in various ways from the viewpoint of execution order and information to be checked, e.g. first assigned number/sub-address and then compatibility or vice versa.

2 If an incoming call, offered with addressing information, is always to be awarded to the addressed user, all users connected to the same passive bus should have an assigned number or sub-address.

Superseded by a more recent version

B.3.2 Network-to-user compatibility checking

When the network is providing a bearer service at the called side, the user shall check that the bearer service offered by the network in the Bearer capability information element matches the bearer services that the user is able to support. If a mismatch is detected, then the user shall either ignore or reject the offered call using cause No. 88, *incompatible destination* (see 5.2.2).

B.3.3 User-to-user compatibility checking

The called side terminal equipment shall check that the content of the Low layer compatibility information element is compatible with the functions it supports.

The Low layer compatibility information element (if available) shall be used to check compatibility of low layers (e.g. from layer 1 to layer 3, if layered according to the OSI model).

NOTE – The Bearer capability information element is also checked (see B.3.2). Therefore, if any conflict from duplication of information in the Bearer capability and the Low layer compatibility information elements is detected, this conflict shall be resolved according to Annex I, e.g. the conflicting information in the Low layer compatibility information element shall be ignored.

If the Low layer compatibility information element is not included in an incoming SETUP message, the Bearer capability information element shall be used to check the compatibility of low layers.

The called terminal equipment may check the High layer compatibility information element (if present) as part of user-to-user compatibility checking procedures, even if the network only supports bearer services.

If a mismatch is detected in checking any of the information elements above, then the terminal equipment shall either ignore or reject the offered call using cause No. 88, *incompatible destination* (see 5.2.2).

B.3.4 User action tables

Tables B.1, B.2 and B.3 show the action which shall be carried out as a result of compatibility checking with the calling user's request for a bearer service and/or teleservice.

B.4 Interworking with existing networks

Limitations in network or distant user signalling (e.g. in the case of an incoming call from a PSTN or a call from an analogue terminal) may restrict the information available to the called user in the incoming SETUP message. A called user should accept limited compatibility checking (e.g. without the High layer compatibility information element) if a call is routed from an existing network which does not support High layer compatibility information element transfer.

In cases where the network cannot provide all incoming call information, or where the network is not aware of the existence or absence of some service information (such as a compatibility information), the incoming SETUP message includes a Progress indicator information element, containing progress indicator No. 1, *call is not end-to-end ISDN; further call progress information may be available in band*, or No. 3, *origination address is non-ISDN* (see Annex G).

The terminal equipment receiving a SETUP with a Progress indicator information element shall modify its compatibility checking, the terminal equipment should regard the compatibility as successful if it is compatible with the included information, which as a minimum, will be the Bearer capability information element. A terminal equipment expecting information in addition to the Bearer capability information element in a full ISDN environment need not reject the call if such information is absent but a Progress indicator information element is included.

Superseded by a more recent version

TABLE B.1/Q.931

Bearer capability compatibility checking

BC mandatory info element	Point-to-point data link (Note 1)	Broadcast data link (Note 1)	
Compatible	Proceed	Proceed	
Incompatible	Reject (5.2.5.1)	Ignore [5.2.5.1 a] (Note 2)	Reject [5.2.5.1 b] (Note 2)

TABLE B.2/Q.931

Low layer and high layer compatibility checking – Compatibility assured with the available description of the call

LLC/HLC Compatibility assured	Point-to-point data link (Note 1)		Broadcast data link (Note 1)		
Compatible	Accept		Accept		
Incompatible	Reject (5.2.5.1)	Attempt low layer compatibility negotiation (Annex J)	Ignore [5.2.5.1 a] (Note 2)	Reject [5.2.5.1 b] (Note 2)	Attempt low layer compatibility negotiation (Annex J)

TABLE B.3/Q.931

Low layer and high layer compatibility checking – Compatibility not assured with the available description of the call

LLC/HLC Compatibility not assured	Point-to-point data link (Note 1)		Broadcast data link (Note 1)	
HLC or LLC Present	Accept or reject (Note 3)	Attempt low layer compatibility negotiation (Annex J)	Accept or reject (Note 3)	Attempt low layer compatibility negotiation (Annex J)

NOTES to Tables B.1, B.2 and B.3

- 1 For broadcast data link terminal equipment which is explicitly addressed using sub-addressing or the appropriate part of the called party number, the point-to-point column in the above table shall be used.
- 2 When a terminal equipment on a broadcast data link is incompatible, an option of “ignore or reject” is permitted (see 5.2.2).
- 3 Some terminal equipment on this interface may understand the High layer compatibility or Low layer compatibility information elements and would reject the call if incompatible.

Superseded by a more recent version

Annex C Transit network selection

(This annex forms an integral part of this Recommendation)

This annex describes the processing of the Transit network selection information element.

C.1 Selection not supported

Some networks may not support transit network selection. In this case, when a Transit network selection information element is received, that information element is processed according to the rules for unimplemented non-mandatory information elements (see 5.8.7.1).

C.2 Selection supported

When transit network selection is supported, the user identifies the selected transit network(s) in the SETUP message. One Transit network selection information element is used to convey a single network identification.

The user may specify more than one transit network. Each identification is placed in a separate information element. The call would then be routed through the specified transit networks in the order listed in the SETUP. For example, a user lists networks A and B, in that order, in two Transit network selection information elements within a SETUP message. The call is first routed to network A (either directly or indirectly), and then to network B (either directly or indirectly), before being delivered.

As the call is delivered to each selected network, the corresponding transit selection may be stripped from the call establishment signalling, in accordance with the relevant internetwork signalling arrangement. The Transit network selection information element(s) is/are not delivered to the destination user.

No more than four Transit network selection information elements may be used in a single SETUP message.

When a network cannot route the call because the route is busy, the network shall initiate call clearing in accordance with 5.3 with cause No. 34, *no circuit/channel available*.

If a network does not recognize the specified transit network, the network shall initiate call clearing in accordance with 5.3, with cause No. 2, *no route to specified transit network*. The diagnostic field shall contain a copy of the contents of the Transit network selection information element identifying the unreachable network.

A network may screen all remaining Transit network selection information elements to

- a) avoid routing loops; or
- b) ensure an appropriate business relationship exists between selected networks; or
- c) ensure compliance with national and local regulations.

If the transit network selection is of an incorrect format, or fails to meet criteria a), b) or c), the network shall initiate call clearing in accordance with 5.3, with cause No. 91, *invalid transit network selection*.

When a user includes the Transit network selection information element, pre-subscribed default Transit network selection information (if any) is overridden.

Superseded by a more recent version

Annex D

Extensions for symmetric call operation

(This annex forms an integral part of this Recommendation)

D.1 Additional message handling

In symmetric applications, the SETUP message will contain a Channel Identification information element indicating a particular B-channel to be used for the call. A point-to-point data link shall be used to carry the SETUP message.

The procedure described in clause 5 for the user side should normally be followed. Where additional procedures are required, they are detailed below.

D.1.1 B-channel selection – Symmetric interface

Only B-channels controlled by the same D-channel will be the subject of the selection procedure. The selection procedure is as follows:

- a) The SETUP message will indicate one of the following:
 - 1) channel is indicated, no acceptable alternative; or
 - 2) channel is indicated, any alternative is acceptable.
- b) In cases 1) and 2), if the indicated channel is acceptable and available, the recipient of the SETUP message reserves it for the call. In case 2), if the recipient of the SETUP message cannot grant the indicated channel, it reserves any other available B-channel associated with the D-channel.
- c) If the SETUP message included all information required to establish the call, the recipient of SETUP message indicates the selected B-channel in a CALL PROCEEDING message transferred across the interface and enters the Incoming Call Proceeding state.
- d) If the SETUP message did not include all the information required to establish the call, B-channel is indicated in a SETUP ACKNOWLEDGE message sent across the interface. The additional call establishment information, if any, is sent in one or more INFORMATION messages transferred across the interface in the same direction as the SETUP message. When all call establishment information is received, a CALL PROCEEDING ALERTING or CONNECT message, as appropriate, is transferred across the interface.
- e) In case 1) if the indicated B-channel is not available, or in case 2) if no B-channel is available, a RELEASE COMPLETE message with a cause value of No. 44, *requested circuit/channel not available*, or No. 34, *no circuit/channel available*, respectively, is returned to the initiator of the call. The sender of this message remains in the Null state.
- f) If the channel indicated in the CALL PROCEEDING or SETUP ACKNOWLEDGE message is unacceptable to the initiator of the call, it clears the call in accordance with 5.3.

D.1.2 Call confirmation

Upon receipt of a SETUP message, the equipment enters the Call Present state. Valid responses to the SETUP message are a SETUP ACKNOWLEDGE, an ALERTING, a CALL PROCEEDING, a CONNECT or a RELEASE COMPLETE message.

If the indicated channel is acceptable to the initiator of the call, the initiator shall attach to the indicated B-channel.

D.1.3 Clearing by the called user employing user-provided tones/announcements

In addition to the procedures described in 5.3.3, if the bearer capability is either audio or speech, the called user or private network may apply in-band tones/announcements in the clearing phase. When in-band tones/announcements are provided, the DISCONNECT message contains progress indicator No. 8, *in-band information or appropriate pattern is now available*, and the called user or private network proceeds similarly as stipulated in 5.3.4.1 for the network.

Superseded by a more recent version

D.1.4 Active indication

Upon receipt of a CONNECT message, the initiator of the call shall respond with a CONNECT ACKNOWLEDGE message and enter the Active state.

D.2 Timers for call establishment

User end points implement the network side timers T301, T303 and T310 along with the corresponding network side procedures for actions taken upon expiration of these timers. See Table 9-2 for the call establishment user-side timers and procedures.

D.3 Call collisions

In symmetric arrangements, call collisions can occur when both sides simultaneously transfer a SETUP message indicating the same channel. In the absence of administrative procedures for assignment of channels to each side of the interface, the following procedure is employed.

First, one side of the interface will be designated the *network* and the other side of the interface will be designated the *user*. Second, for the three possible scenarios where the same channel is indicated by combinations of preferred and exclusive from the user and network sides, the following procedure is used:

a) *Network preferred, user preferred*

The network preferred channel is awarded and an alternate channel is indicated in the first response to the user SETUP message.

b) *Network exclusive, user exclusive*

The network exclusive channel is awarded and the user SETUP message is cleared with a RELEASE COMPLETE message with cause No. 34, *no circuit/channel available*.

c) *Network preferred, user exclusive, or network exclusive, user preferred*

The side of the interface with an exclusive indicator in a SETUP message is awarded the channel and an alternate channel is indicated in the first response to the side using a preferred indicator in the SETUP message.

Channel identification is allowed in both directions for ALERTING and CONNECT.

Annex E

Network specific facility selection

(This annex forms an integral part of this Recommendation)

This annex describes the processing of the Network-specific facilities information element. The purpose of this information element is to indicate which network facilities are being invoked.

E.1 Default provider

When the length of the network identification field is set to zero in the Network-specific facilities information element, then the services identified in this information element are to be provided by the network side of the interface receiving the information element (default provider). If the Network-specific facilities information element is recognized but the network facilities are not understood, then this information element is processed according to rules for non-mandatory information element content error (see 5.8.7.1).

E.2 Routing not supported

Some networks may not support the routing to the remote network of the contents of the Network-specific facilities information element. In this case, when a Network-specific facilities information element is received, that information element is processed according to the rules for unimplemented non-mandatory information elements (see 5.8.7.1).

Superseded by a more recent version

E.3 Routing supported

When Network-specific facility information element routing is supported, the user identifies the network provider in this information element in the Q.931 SETUP message. One Network-specific facility information element is used to identify a network provider.

The user may specify more than one network provider by repeating the Network-specific facilities information element. Each identification is placed in a separate information element. The information is routed to the indicated network provider as long as the call is also handled by the network provider (see Annex C, Transit network selection). For example, if the user lists network providers A and B in separate Network-specific facilities information elements in a call control message, there must be corresponding Transit network selection information elements in the SETUP message identifying those networks (or default call routing via A and B that was established prior to call establishment).

As the signalling messages containing Network-specific facilities information elements are delivered to the indicated remote network, they may be stripped from the signalling messages, in accordance with the relevant internetworking signalling arrangement. The Network-specific facilities information elements may be delivered to the identified user.

No more than four Network-specific facilities information elements may be used in a SETUP message. When the information element is repeated, the order of presentation of the elements in a message is not significant. Further, there does not have to be a one-to-one correspondence between Network-specific facilities information elements and Transit network selection information elements.

If a network cannot pass the information to the indicated network provider, either due to

- the network indicated is not part of the call path; or
- no mechanism exists for passing the information to identified network,

the network shall initiate call clearing in accordance with 5.3, with cause No. 2, *no route to specified transit network*. The diagnostic field may optionally contain a copy of the first 5 octets of the Network-specific facilities information element.

When the user includes the Network-specific facilities information element in the SETUP message, pre-subscribed default service treatment (if any) is overridden.

Annex F D-channel backup procedures

(This annex forms an integral part of this Recommendation)

F.0 Foreword

The procedure defined in this annex can be used when non-associated signalling is applied to multiple primary rate access arrangements. This feature can be provided on a subscription basis and is network dependent.

F.1 General

In associated signalling, the D-channel signalling entity can only assign calls to channels on the interface containing the D-channel. When the D-channel signalling entity can assign calls to channels on more than one interface (including the one containing the D-channel), this is called non-associated signalling. Figure F.1 is an example of associated signalling used on each of the three interfaces between a user (e.g. a PABX) and a network. Replacing associated signalling with non-associated signalling on these interfaces results in the example shown in Figure F.2.

When non-associated signalling is employed, the reliability of the signalling performance for the ISDN interfaces controlled by the D-channel may be unacceptable. To improve the reliability, a D-channel backup procedure employing a standby D-channel is necessary. The next subclause describes the backup procedure which is optional for end-points that use non-associated signalling.

Superseded by a more recent version

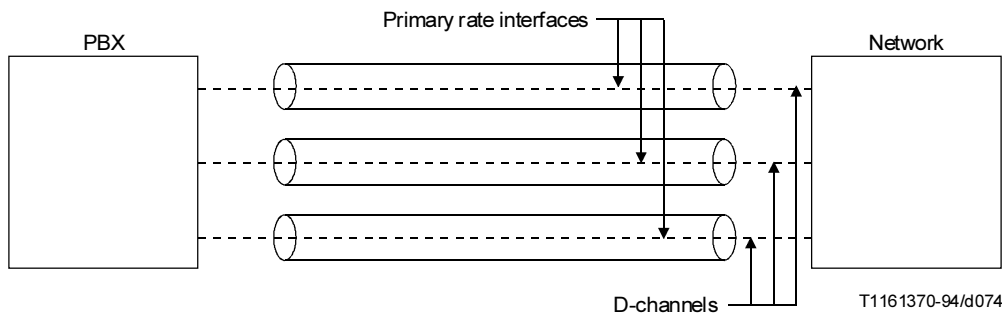

FIGURE F.1/Q.931

Example of associated signalling on each of the three primary rate interfaces

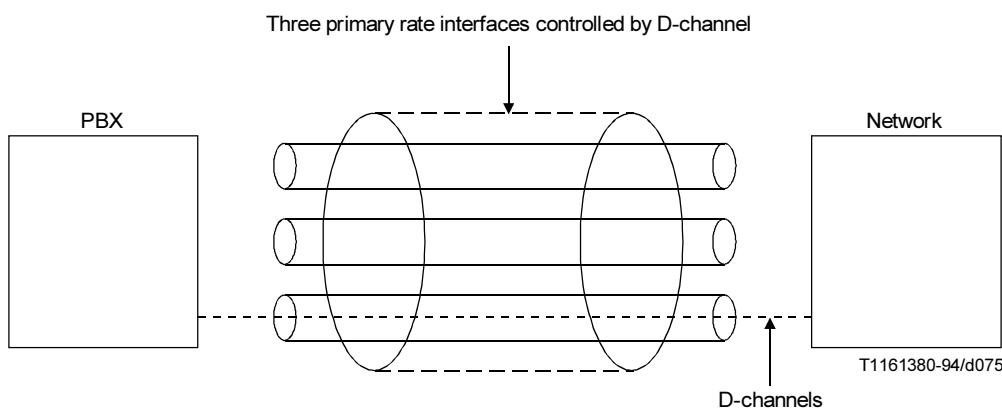

FIGURE F.2/Q.931

Example of non-associated signalling controlling three primary rate interfaces

F.2 D-channel backup procedure

F.2.1 Role of each D-channel

When two or more interfaces connect a network and a user, a primary D-channel (labelled "one") is always present on one interface. On a different interface, a secondary D-channel (labelled "two") is present that can also send signalling packets. Figure F.3 shows the addition of a secondary (i.e. backup) D-channel to the arrangement shown in Figure F.2.

D-channel one is used to send signalling packets across the user-network interface for multiple interfaces including the interface containing D-channel two. D-channel two is in a standby role and is active at layer 2 only. All SAPI groups (e.g. 0, 16 and 63) are alive and can send packets. At periodic intervals determined by the appropriate layer 2 timer associated with SAPI 0, a link audit frame will be sent on the point-to-point signalling link with DLCI = 0 of D-channel two.

Since D-channel two is in a standby role, load sharing between D-channels one and two is not possible. Furthermore, D-channel two can not serve as a B-channel when it is in a standby role. Lastly, D-channel two can only back up the signalling functions provided by D-channel one and not some other D-channel on a different interface.

Superseded by a more recent version

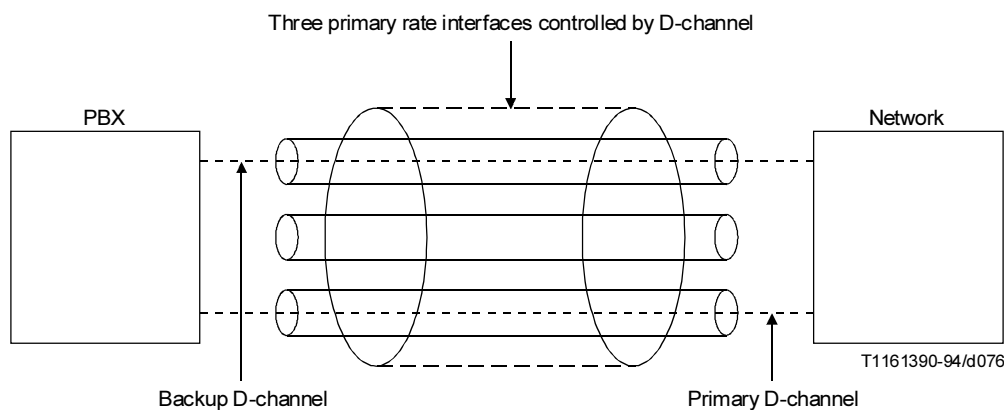

FIGURE F.3/Q.931

Example of non-associated signalling with backup D-channel controlling three primary rate interfaces

F.2.2 Switchover of D-channels

Failure of D-channel one is determined by the receipt of a DL-RELEASE indication primitive from the data link layer. At this point, optionally additional attempts to re-establish this D-channel may be initiated. Otherwise, it is assumed that D-channel one has failed.

Two states are defined for any D-channel in a backup arrangement. A D-channel is termed out-of-service when layer 2 remains in the TEI-assigned state, after being periodically requested by layer 3 to establish multiple-frame operation. A D-channel is termed maintenance busy when layer 2 is held in the TEI-assigned state by layer 3. While in the maintenance busy condition, the response to an invitation for link establishment is met with the transmission of a DM (Disconnected Mode).

When the D-channel one has failed and if D-channel two is not in an out-of-service condition, the layer 3 shall place D-channel one in a maintenance busy condition, start timer T321 and then issue a DL-ESTABLISH request primitive to re-initialize SAPI 0 link 0 of D-channel two. Upon receipt of this primitive, the data link layer issues an SABME command. Timer T200 is started. The end receiving the SABME command on D-channel two follows the remainder of the Q.931 procedures for establishing logical link with DLCI = 0.

Once the logical link with DLCI = 0 in D-channel two is in the Link Established state, the procedure to establish layer 3 call control signalling can begin on the link.

To establish the backup D-channel for carrying call control signalling, layer 3 should issue an appropriate layer 3 message (e.g. a STATUS ENQUIRY on stable call reference numbers). Once a response to that layer 3 message is received, D-channel two is declared to be the active D-channel, normal layer 3 call control signalling may proceed, timer T321 is stopped, and D-channel one is moved to the out-of-service condition. If the maintenance busy timer T321 expires before a response is received to the layer 3 message, D-channel one is moved to the out-of-service condition and an attempt is made to establish the logical link with DLCI = 0 on D-channel one and D-channel two.

If the logical link with DLCI = 0 of both D-channel one and D-channel two are initialized simultaneously, the designated primary shall be chosen as the D-channel for carrying call control signalling. The designated primary D-channel is agreed upon at subscription time by both sides of the interface.

After a switchover, old D-channel two becomes the new D-channel one and old D-channel one becomes the new D-channel two.

Upon completion of appropriate maintenance activity to D-channel two, the logical links for SAPI = 0 and 63 are made active at layer 2 and the D-channel is removed from the out-of-service condition.

D-channels may only be switched again by a failure of D-channel one or a routing or maintenance request from a peer entity.

Superseded by a more recent version

Annex G

Use of progress indicators

(This annex forms an integral part of this Recommendation)

This annex describes the use of the different progress indicator values defined in 4.5.22. Examples of use are given.

- **Progress indicator No. 1** – Indicates that interworking with a non-ISDN has occurred within the network or networks through which the call has traversed.
- **Progress indicator No. 2** – Indicates that the destination user is not ISDN.
- **Progress indicator No. 3** – Indicates that the origination user is not ISDN.
- **Progress indicator No. 4** – Indicates that a call which had left the ISDN has returned to the ISDN at the same point it had left due to redirection within the non-ISDN. This progress indicator would be employed when a prior Q.931 message resulted in a progress indicator No. 1 (*call is not end-to-end ISDN*), being delivered to the calling user.

The use of progress indicators Nos. 1, 2 and 3 is exemplified in the following.

Three interworking situations are identified in the figure below:

- a) interworking with another network;
- b) interworking with a non-ISDN user connected to ISDN;
- c) interworking with non-ISDN equipment within the calling or called user's premises.

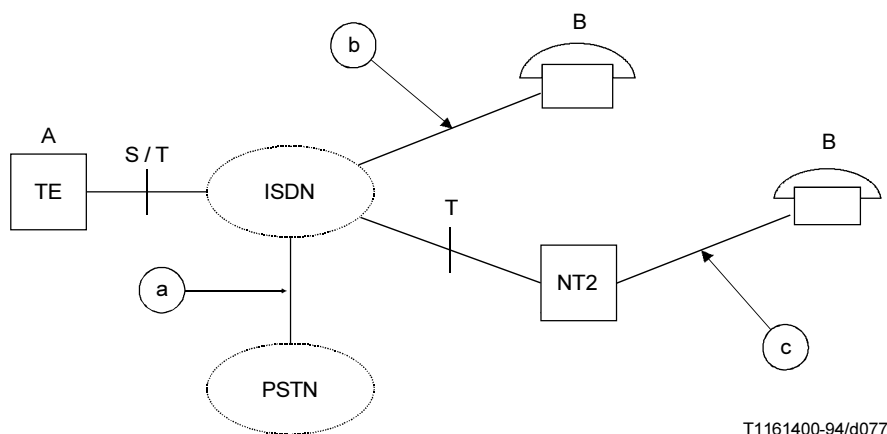

As regards calls from A the following applies:

- case a) – progress indicator No. 1 sent to A;
- case b) – progress indicator No. 2 sent to A;
- case c) – progress indicator No. 2 sent to A (location sub-field = private network).

As regards calls towards A the following applies:

- case a) – progress indicator No. 1 sent to A;
- case b) – progress indicator No. 3 sent to A;
- case c) – progress indicator No. 3 sent to A (location sub-field = private network).

The use of progress indicator No. 4 is exemplified in the following scenarios associated with the Call Forwarding supplementary service. If a call is originated from user A to user B, then as stated above, in the interworking cases b) and c) (see figure), progress indicator No. 2 shall be sent to user A to indicate that interworking has occurred. If subsequently the call is forwarded from user B to user C, and user C is an ISDN user, progress indicator No. 4 shall be sent to user A.

The use of progress indicator No. 8, *in-band information or appropriate pattern now available*, is described in clause 5.

Superseded by a more recent version

Annex H

Message segmentation procedures

(This annex forms an integral part of this Recommendation)

This optional procedure is used on the basis of bilateral agreement between the user and the network.

H.1 Introduction

Layer 3 messages that are longer than the length of frames that the data link layer can support may be partitioned into several segments.

Message segmentation shall only be used when the message length exceeds N201 (defined in Recommendation Q.921 [3]).

The architectural relationship to other Q.931 functions is shown in Figure H.1. These procedures apply only within a specific data link connection and do not impact the procedures in operation on other parallel data link connections.

In order to support expressed needs for applications requiring message lengths of 10 000 octets, or greater, procedures to support those applications are under study. These procedures will consider backward compatibility and methods to allow information on other call references to be interleaved with segments of a long message. The specifics of these procedures are for further study.

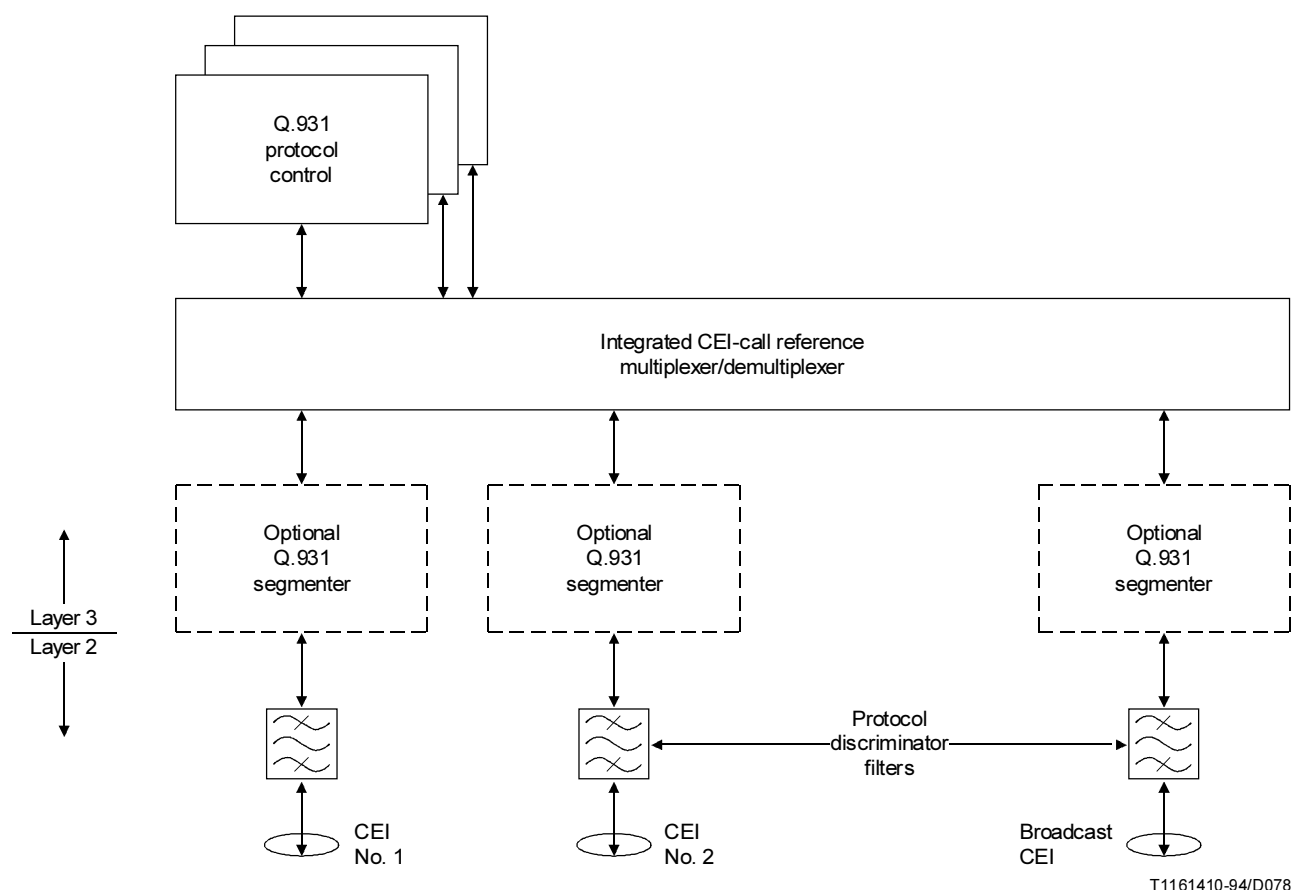

FIGURE H.1/Q.931

Logical architecture containing segmentation function

H.2 Message segmentation

The following rules apply when Q.931 messages are to be segmented for transmission:

- The default maximum number of message segments is 8. If the message is too long to be segmented then a local maintenance activity shall be notified.

Superseded by a more recent version

- b) The first message segment shall begin with the Protocol discriminator information element immediately followed by the Call reference information element, the segment message type, the Segmented message information element, and octets starting with the first octet following the message type of the message being segmented, subject to the maximum length of the segment not exceeding the maximum size of the data link layer information field.
- c) Each subsequent message segment shall begin with the Protocol discriminator information element immediately followed by the Call reference information element, the segment message type, the Segmented message information element, and one or more octets starting with the first octet following the message type of the message being segmented, subject to the maximum length of the segment not exceeding the maximum size of the data link layer information field.
- d) The first segment indicator field of the Segmented message information element shall be set to indicate the first segment of a segmented message, and not set in any other segment.
- e) The number of segments remaining field of the Segmented message information element shall be set to indicate how many more segments are to be sent, see Figure H.2.
- f) The Message type information element shall be coded to indicate a segment message, and the Segmented message information element shall indicate the message type of the original message.
- g) The transmission of a segmented message may be aborted by sending a message or message segment containing a different call reference; sending a message with the message type not coded “segment message”, or stopping the transmission of subsequent message segments pertaining to the same message.
- h) Once the first segment has been transmitted on a particular data link connection, then all remaining segments of that message shall be sent (in order) before any other message (segmented or not) for any other call reference is sent on that data link connection.
- i) The octet order for the segmented message shall be preserved regardless of segment boundary.

H.3 Reassembly of segmented messages

The following rules apply to the receipt and reassembly of segmented Q.931 messages:

- a) A reassembly function, on receiving a message segment containing the Segmented message information element with the first segment indicator indicating “first message”, and containing the call reference and message type (coded as “segment message”) shall enter the Receiving Segmented Message state and accumulate message segments.
- b) Timer T314 shall be initialized or re-initialized upon receipt of a message segment containing the Segmented message information element with a non-zero number of segments remaining field. Timer T314 shall be stopped upon receipt of the last segment, i.e. a message segment containing the Segmented message information element with the number of segments remaining field coded zero. Timer T314 shall not be initialized or re-initialized if error procedures as identified in rules below are initiated.
- c) A reassembly function receiving a message segment with a Segmented message information element should wait for receipt of the last message segment pertaining to the same message, i.e. containing the Segmented message information element with the number of segments remaining field coded zero before delivering the message for further Q.931 processing as specified in 5.8. The reassembly function shall enter the Null state.
- d) Upon expiry of timer T314, the reassembly function shall discard all segments of this message so far received; notify the layer 3 management entity for the data link connection that message segments have been lost and enter the Null state.

NOTE 1 – Subsequent message segments relating to the same message shall be discarded according to rule f).

Superseded by a more recent version

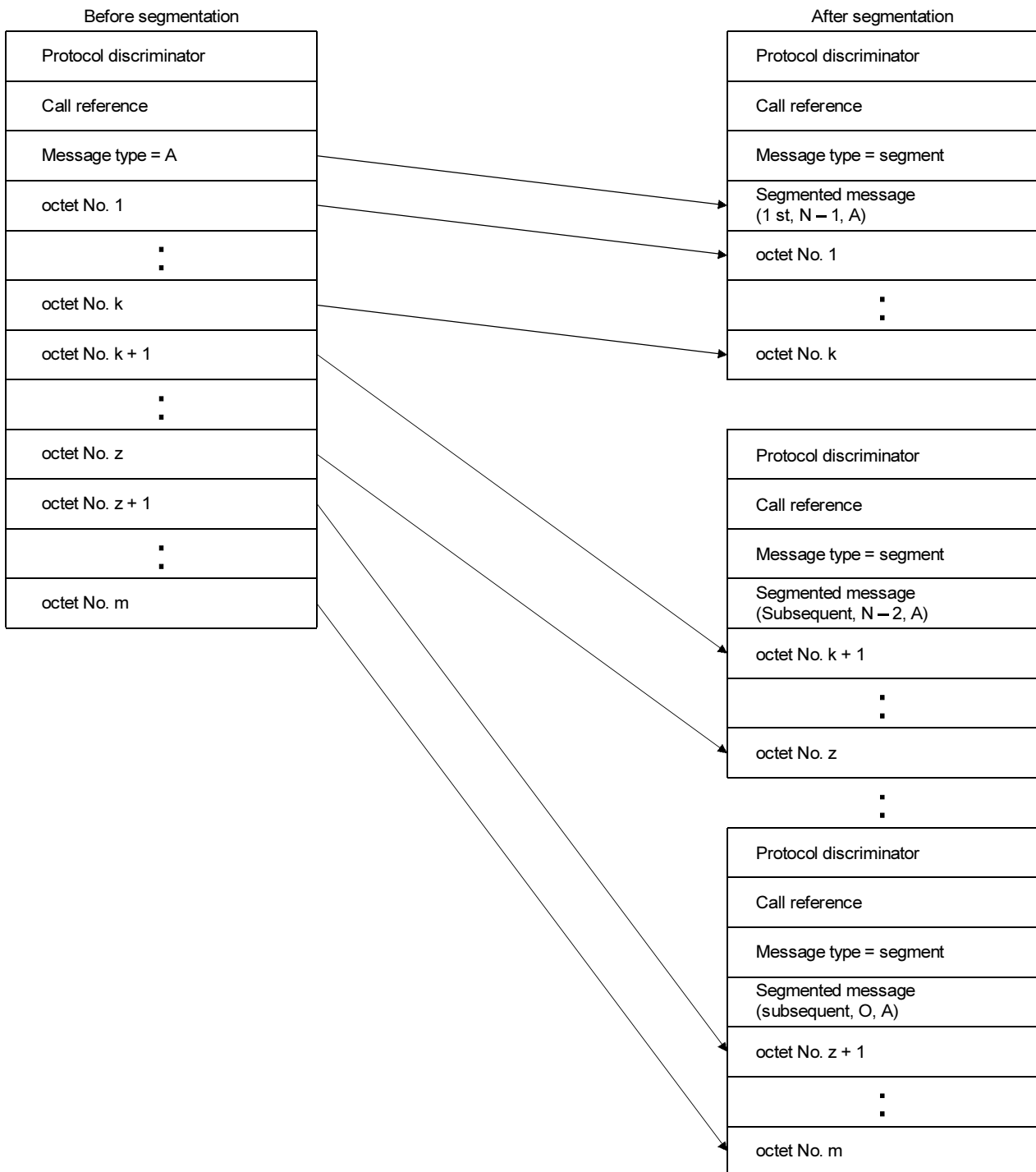

T1161420-94/d079

NOTE – Segmentation may occur at any octet boundary.

FIGURE H.2/Q.931
Relation between Message and Segments

Superseded by a more recent version

- e) A reassembly function, upon receiving eight message segments of the same segmented message without receiving a message segment with a number of segments remaining field of the Segmented message information element coded zero, shall discard all message segments so far received; notify the layer 3 management entity for the data link connection that messages have been discarded, and enter the Null state.

NOTE 2 – Subsequent message segments relating to the same message shall be discarded according to rule f).

- f) A reassembly function, on receiving a message segment containing a Segmented message information element, but with no call reference or Message type information element, while in the Null state shall discard that message segment and remain in the Null state.
- g) A reassembly function, on receiving a message segment containing a Segmented message information element, while in the Receiving Segmented Message state with the number of segments remaining field that is not decremented from the number of segments remaining field in the Segmented message information element of the previous message segment, shall discard all segments of this message so far received, and enter the Null state.

NOTE 3 – Subsequent message segments relating to the same message shall be discarded according to rule f).

- h) If there is a DL-RELEASE indication primitive or DL-ESTABLISH indication primitive received while in the Receiving Segmented Message state, the reassembly function shall discard all received message segments so far received; forward the DL-RELEASE indication primitive or DL-ESTABLISH indication primitive for further Q.931 processing, and enter the Null state.
- i) A reassembly function, upon receiving a message segment with the first segment indicator of the Segmented message information element indicating “subsequent”, while in the Null state, shall discard that message segment, and remain in the Null state.

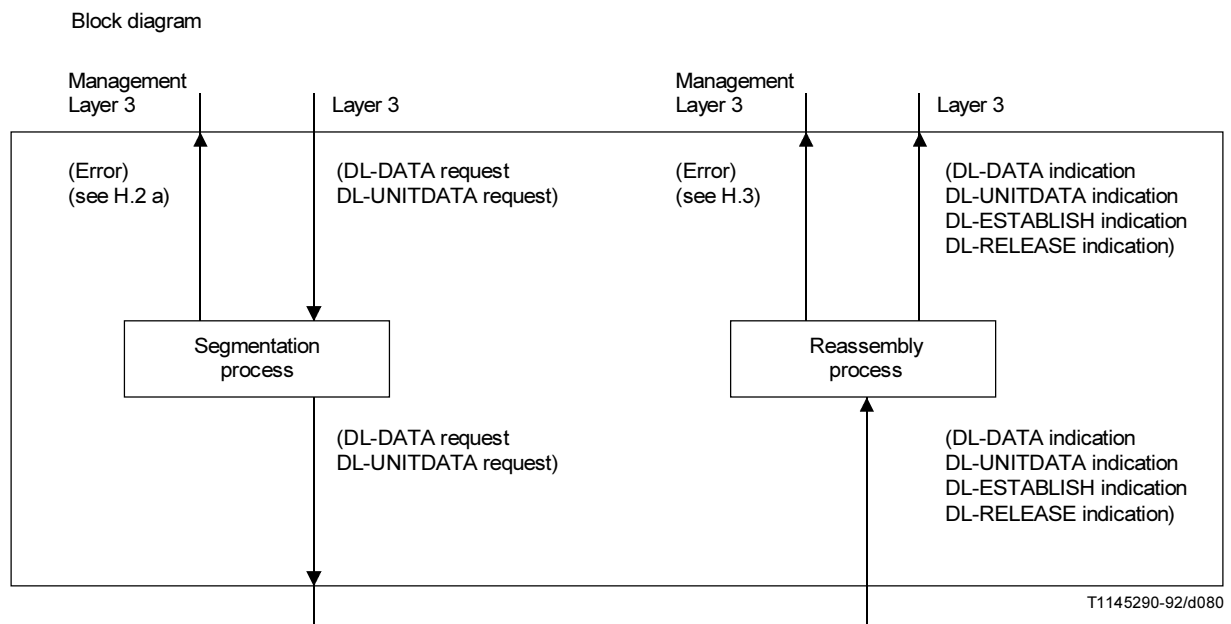

FIGURE H.3/Q.931

Segmentation Functional Interaction Diagram

Superseded by a more recent version

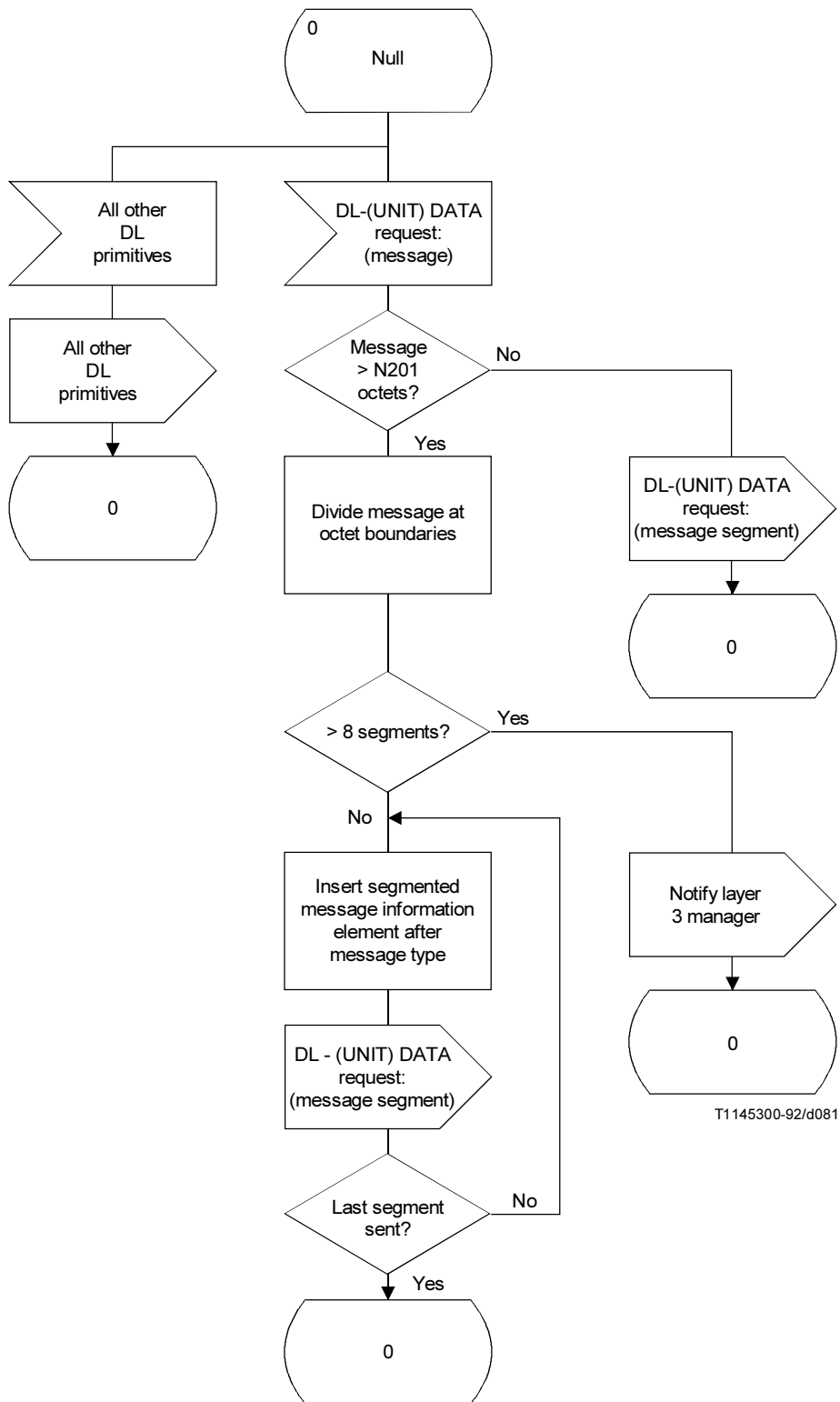

FIGURE H.4/Q.931
Message Segmenter SDL

Superseded by a more recent version

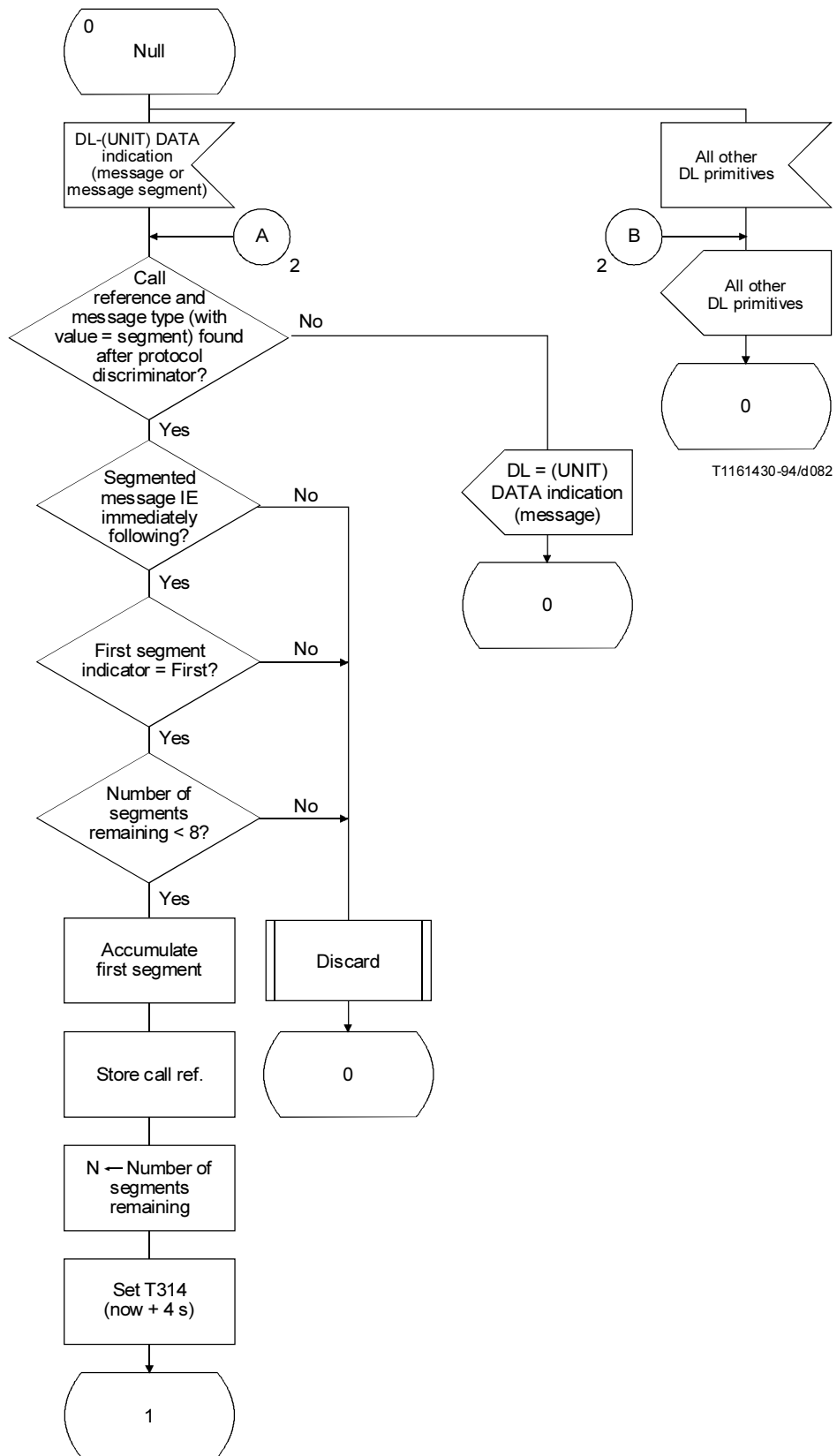
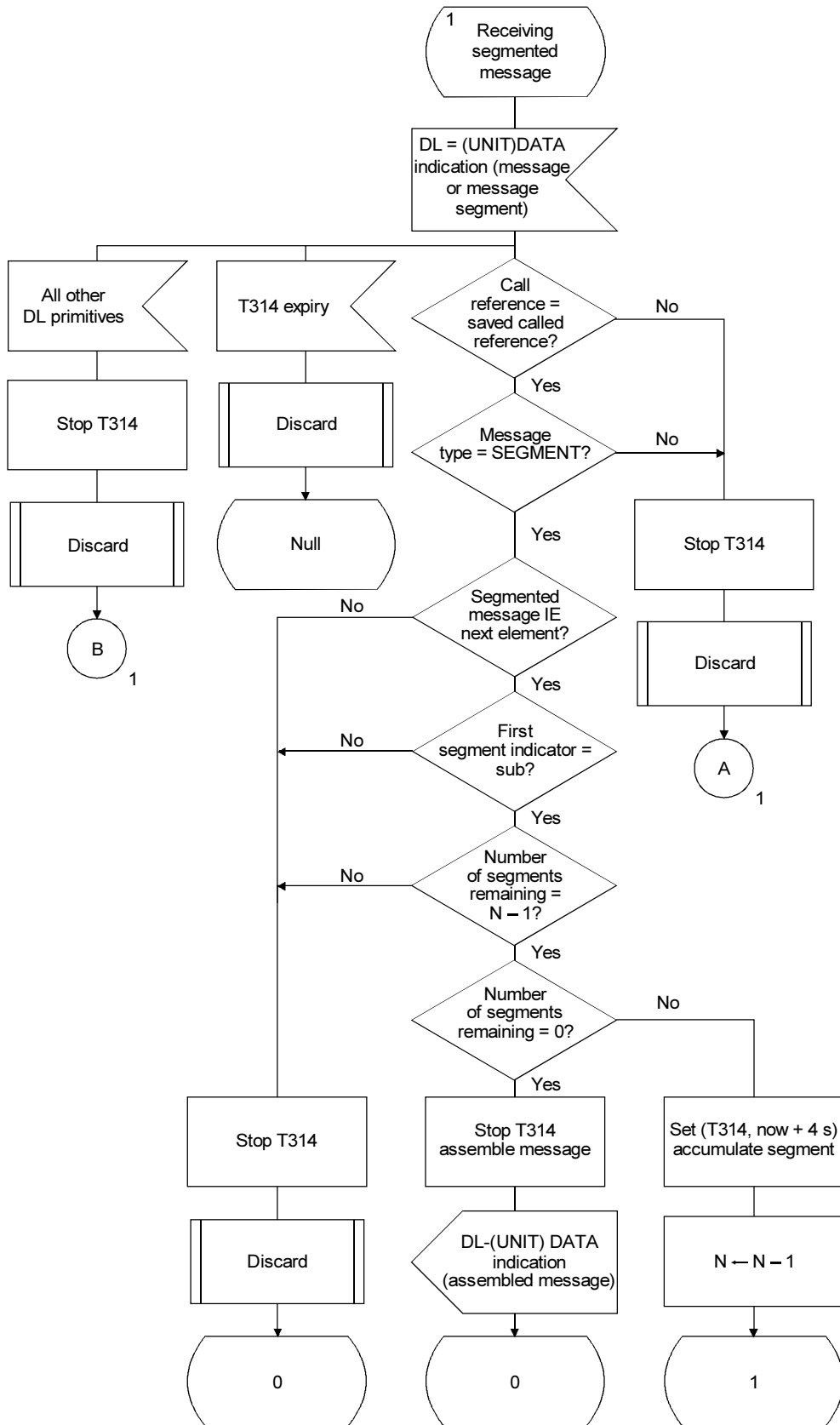

FIGURE H.5/Q.931 (Sheet 1 of 3)

Message Reassembler SDL

Superseded by a more recent version



T1161440-94/d083

FIGURE H.5/Q.931 (Sheet 2 of 3)

Message Reassembler SDL

Superseded by a more recent version

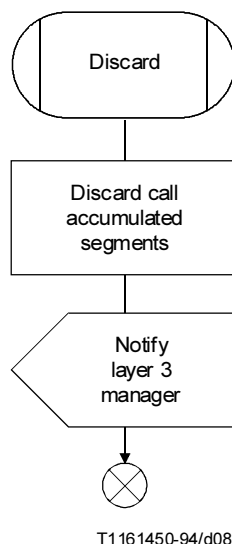

FIGURE H.5/Q.931 (Sheet 3 of 3)
Message Reassembler SDL

Annex I

Low layer information coding principles

(This annex forms an integral part of this Recommendation)

I.1 Purpose

This annex describes principles that shall be used when the calling user specifies information during call set-up regarding low layer capabilities required in the network and by the destination terminal.

NOTE – In this context and throughout this annex the term “called user” is the endpoint entity which is explicitly addressed. This may be an addressed interworking unit (IWU) (see I.500-Series Recommendations [51] and Recommendation X.31 [14] case A).

I.2 Principles

I.2.1 Definitions of types of information

There are three different types of information that the calling ISDN user may specify during call set-up to identify low layer capabilities needed in the network and by the destination terminal:

- a) **type I information** is information about the calling terminal which is only used at the destination end to allow a decision regarding terminal compatibility. An example would be modem type. This information is encoded in octets 5 to 7 of the Low layer compatibility information element;
- b) **type II information** is the selection of bearer service from the choices of bearer services offered by the network to which the calling user is connected. This type of information is present even if no interworking occurs. An example is unrestricted digital information (UDI). This information is coded in
 - i) octets 3 and 4 of the Bearer capability information element when the transfer mode required by the calling user is circuit mode;
 - ii) octets 3, 4, 6 and 7 of the Bearer capability information element when the transfer mode required by the calling user is packet mode;

Superseded by a more recent version

- c) **type III information** is information about the terminal or intended call which is used to decide destination terminal compatibility and possibly to facilitate interworking with other ISDNs or other dedicated networks. An example is A-law encoding. This information is encoded in octet 5 of the Bearer capability information element.

I.2.2 Examination by network

Type I information is user-to-user (i.e. not examined by network) while both types II and III should be available for examination by the destination user and the network. The Low layer compatibility information element is an information element which is not examined by the network while the Bearer capability information element is an information element which is examined by the user and the network.

I.2.3 Location of type I information

Type I information (i.e. terminal information only significant to the called user) shall, when used, be included in the Low layer compatibility information element.

I.2.4 Location of type II and III information

Type II (i.e. bearer selection) information shall be included in the Bearer capability information element. Type III information, when used, is included in the Bearer capability information element. The network may use and modify the information (e.g. to provide interworking). The rationale for the user including some terminal related information in the type III information (interworking related) is shown by the following example.

Normally with UDI, the rate adaption technique chosen is related to the terminal. The specification of a particular rate adaption scheme with a UDI bearer service could allow a compatibility decision by the destination terminal in a purely ISDN situation. However, it could also conceivably be used to allow interworking with a PSTN, assuming that the appropriate functions (i.e. data extraction, modem pool) are available at the interworking unit.

If the rate adaption information is carried in the Low layer compatibility information element, and not in the Bearer capability information element, then interworking by the network providing the bearer capability would not be possible. However, if the rate adaption information is carried in the Bearer capability information element, interworking would be possible.

Hence, there is some terminal related information which may be considered interworking related. The consequence for the calling user of not including such terminal related information in the Bearer capability information element is that the call may not be completed if an interworking situation is encountered.

I.2.5 Relationship between Bearer capability and Low layer compatibility information elements

There shall be no contradiction of information between the Low layer compatibility and the Bearer capability at the originating side. However, as some Bearer capability code points may be modified during the transport of the call, this principle implies that there should be minimal duplication of information between Bearer capability information element and Low layer compatibility information element.

NOTE – If as a result of duplication, a contradiction occurs between the Bearer capability information element and the Low layer compatibility information element at the terminating side, the receiving entity shall ignore the conflicting information in the Low layer compatibility information element.

The following example, dealing with the specification of the encoding scheme used by the terminal for the speech or 3.1 kHz audio bearer services, shows the consequences of duplication.

It is expected that some ISDNs will support only A-law and some only μ -law, with conversion provided by the μ -law network. (See Recommendation G.711.) If the encoding scheme is specified in both the Bearer capability information element and the Low layer compatibility information element, interworking between two ISDNs might require a change of the user information layer 1 protocol in the Bearer capability information element (e.g. from A-law to μ -law), while the encoding scheme specified in the Low layer compatibility information element would presumably be forwarded to the destination unchanged. Since, to determine compatibility, the destination terminal examines both the Bearer capability information element and the Low layer compatibility information element, it would receive conflicting information regarding the encoding scheme used.

Superseded by a more recent version

I.3 Information classification

The following are the examples of classifying low layer information currently identified. This information is provided to facilitate understanding of the characteristics of types II and III information.

I.3.1 Examples for speech and 3.1 kHz audio bearer services

- a) *Type II information (common to all applications using these bearer services):*
- information transfer capability = speech or 3.1 kHz audio;
 - information transfer mode = circuit;
 - information transfer rate = 64 kbit/s;
 - user information layer 1 protocol = A/ μ -law.
- b) *Type III information for interworking with CSPDN (3.1 kHz audio applications are assumed) – Figure I.1:*
- user information layer 1 protocol = rate adaption + user rate (see Note);
- NOTE – Only those profiles conforming to CCITT standardized rate adaption are allowed when only the above information is provided.
- c) *Type III information for interworking with PSTN:*
- i) voice applications – Figure I.2:
- user information layer 1 protocol = A/ μ -law;
- ii) voice band data applications – Figure I.3:
- user information layer 1 protocol = A/ μ -law.

I.3.2 Examples for 64 kbit/s UDI circuit mode bearer service

- a) *Type II information (common):*
- information transfer capability = unrestricted digital information;
 - information transfer mode = circuit;
 - information transfer rate = 64 kbit/s.
- b) *Type III information for interworking with PSPDN (packet applications) – Figure I.4:*
- no type III information is required.
- c) *Type III information for interworking with PSTN:*
- i) voice applications – Figure I.5:
- no type III information is required;
- ii) rate-adapted data applications – Figure I.6:
- no type III information is required.
- d) *Type III information for interworking with PSTN with end-to-end digital connectivity (data applications) – Figure I.7:*
- user information layer 1 protocol = rate adaption + user rate (see Note).
- NOTE – The profile described in Recommendation I.463 [52] is allowed.

Superseded by a more recent version

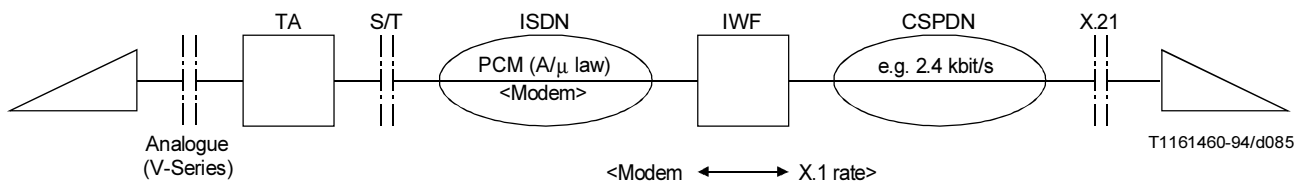

NOTE – Is user rate sufficient to specify the type of modem at IWF?

FIGURE I.1/Q.931

BC = 3.1 kHz audio – Voice → CSPDN

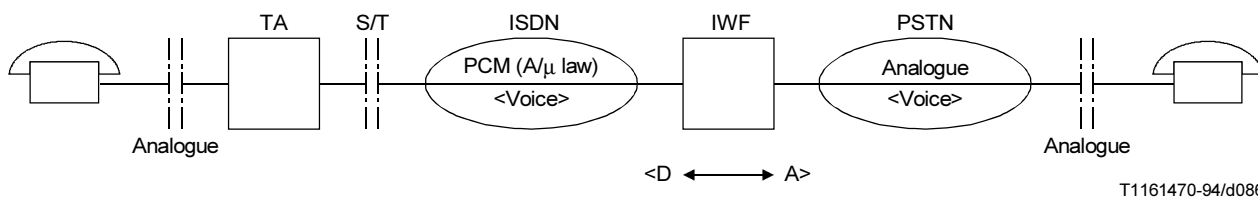

FIGURE I.2/Q.931

BC = 3.1 kHz audio – Voice → PSTN

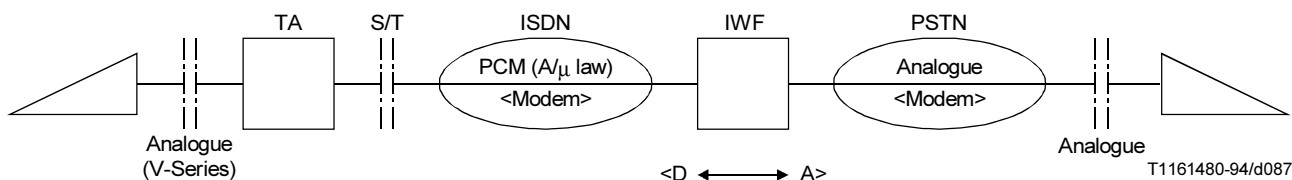

FIGURE I.3/Q.931

BC = 3.1 kHz audio – Voice → PSTN

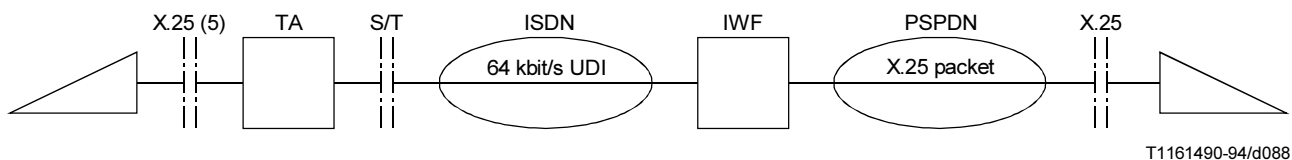

FIGURE I.4/Q.931

BC = 64 kbit/s UDI – Packet application → PSPDN

Superseded by a more recent version

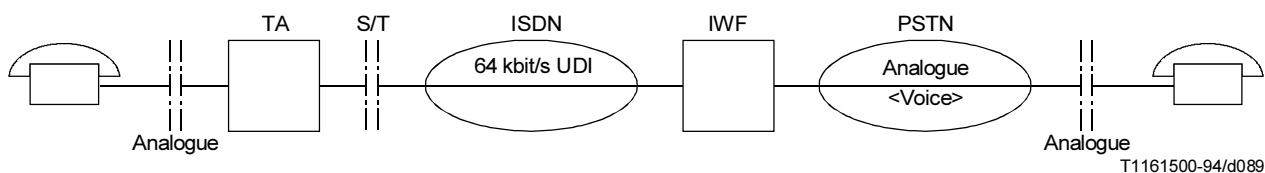

FIGURE I.5/Q.931

BC = 64 kbit/s UDI – Voice → PSTN

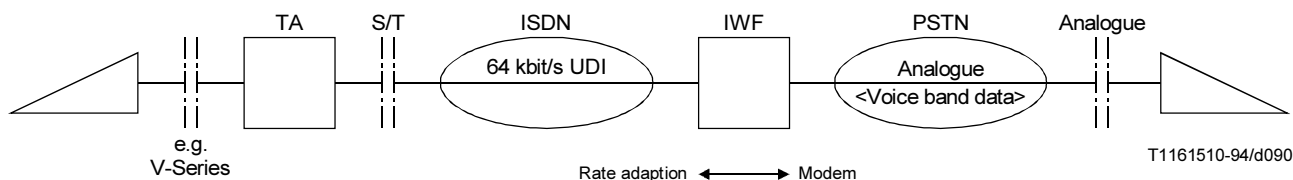

FIGURE I.6/Q.931

BC = 64 kbit/s UDI – Rate adapter data → PSTN

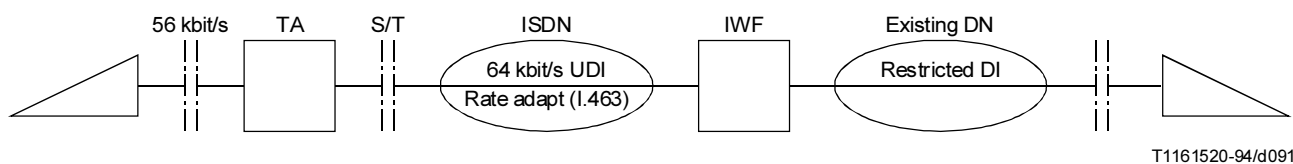

FIGURE I.7/Q.931

BC = 64 kbit/s UDI – Existing digital network

I.3.3 Examples for ISDN virtual-circuit bearer service

a) *Type II information (common):*

- information transfer capability = unrestricted digital information;
- information transfer mode = packet;
- information transfer rate = -- -- --;
- user information layer 1 protocol = rate adaption + user rate (see Note 1);
- user information layer 2 protocol = LAPB (see Note 2);
- user information layer 3 protocol = X.25 [5] packet layer protocol (see Note 2).

NOTES

1 This parameter is included only when user packet information flow is rate adapted. Only those profiles conforming to Recommendation X.31 are allowed when only the above information is provided for layer 1 protocol.

2 Only those profiles conforming to Recommendation X.31 are used. See Figures I.8 to I.10.

b) *Type III information for interworking with PSPDN, CSPDN, PSTN:*

- no type III information is necessary.

Superseded by a more recent version

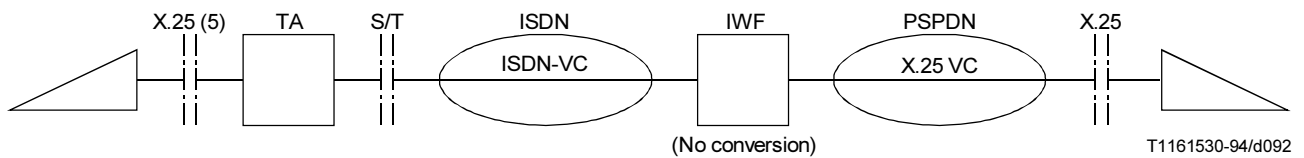

FIGURE I.8/Q.931

BC = ISDN virtual circuit (VC) → PSPDN

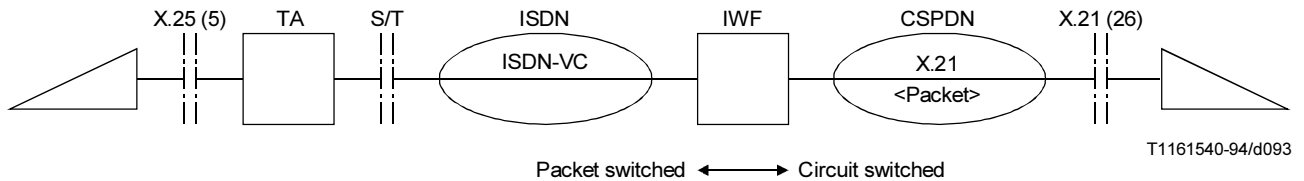

FIGURE I.9/Q.931

BC = ISDN virtual circuit (VC) → CSPDN

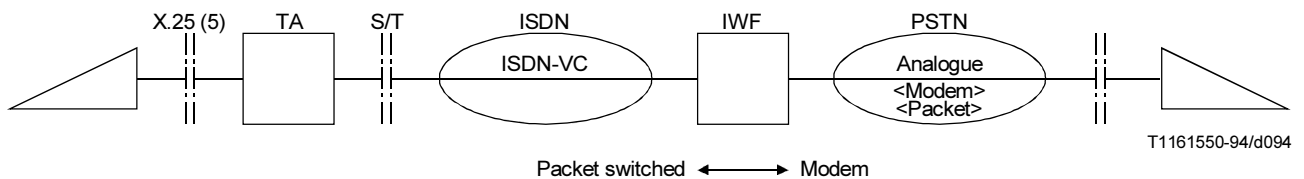

FIGURE I.10/Q.931

BC = ISDN virtual circuit (VC) → PSTN

I.4 Scenarios outside the scope of ISDN standardization

I.4.1 Examples for speech and 3.1 kHz audio bearer services

a) *Type II information (common):*

- information transfer capability = speech or 3.1 kHz audio;
- information transfer mode = circuit;
- information transfer rate = 64 kbit/s;
- user information layer 1 protocol = A/μ-law.

b) *Type III information for interworking with PSTN – Voice band data applications – Modem type conversion occurs – Figure I.11:*

- user information layer 1 protocol = rate adaption + user rate + other attributes (if required).

Superseded by a more recent version

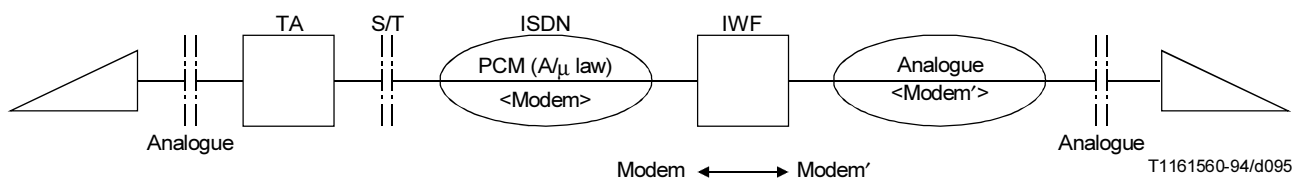

NOTE – This scenario seems to be a part of PSTN services.

FIGURE I.11/Q.931

BC = 3.1 kHz audio – Voice band → PSTN

I.4.2 Examples for 64 kbit/s UDI circuit mode bearer services

a) *Type II information (common):*

- information transfer capability = unrestricted digital information;
- information transfer mode = circuit;
- information transfer rate = 64 kbit/s.

b) *Type III information for interworking with PSTN – Voice band data applications – Figure I.12:*

- no type III information is required.

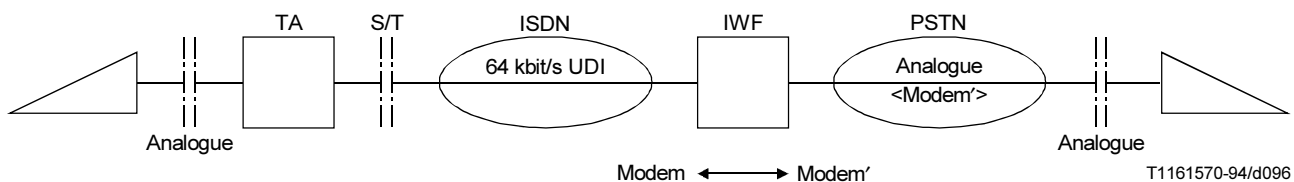

NOTE – This scenario seems to be a combination of interworking with PSTN and a part of PSTN services.

FIGURE I.12/Q.931

BC = 64 kbit/s UDI – Voice-band data → PSTN

Annex J

Low layer compatibility negotiation

(This annex forms an integral part of this Recommendation)

This annex describes an additional low layer compatibility checking procedure that may be applied by the user.

J.1 General

The purpose of the Low layer compatibility information element is to provide a means which should be used for compatibility checking by an addressed entity (e.g. a remote user or an interworking unit or high layer function network node addressed by the calling user). The Low layer compatibility information element is transferred transparently by an ISDN between the call originating entity (e.g. the calling user) and the addressed entity.

Superseded by a more recent version

The user information protocol fields of the Low layer compatibility information element indicate the low layer attributes at the call originating entity and the addressed entity. This information is not interpreted by the ISDN and therefore the bearer capability provided by the ISDN is not affected by this information. The call originating entity and the addressed entity may modify the low layer attributes by the negotiation described below if that can be supported by the bearer capability actually provided by the ISDN.

The Low layer compatibility information element is coded according to 4.5.19.

J.2 Low layer capability notification to the called user

When the calling user wishes to notify the called user of its information transfer attributes (type II information – octets 3 and 4) or any low layer protocol (type I information - octets 5 to 7) to be used during the call and not already identified in the Bearer capability information element, then the calling user shall include a Low layer compatibility information element in the SETUP message; this element is conveyed by the network and delivered to the called user. However, if the network is unable to convey this information element, it shall act as described in 5.8.7.1 (unrecognized information element).

J.3 Low layer compatibility negotiation between users

If the negotiation indicator (see 4.5) of the Low layer compatibility information element included in the SETUP message is set to “Out-band negotiation is possible (octet 3a, bit 7)”, then one or more of the low layer protocol attribute(s) may be negotiated. In this case, the called user responding positively to the call may include a Low layer compatibility information element in the CONNECT message. This element will be conveyed transparently by the network and delivered to the calling user in the CONNECT message.

NOTE – Only the low layer protocol attributes may be negotiated and therefore the information transfer attributes (octets 3 to 4), if returned by the called user in the CONNECT message, will be identical to the ones received in the Low layer compatibility information element contained in the SETUP message.

If, for any reason, the network is unable to convey this information element, it shall act as described in 5.8.7.1 (unrecognized information element). Users are advised not to include in the Low layer compatibility information element sent from the called user to the calling user, attributes which would have the same value as the ones contained in the Low layer compatibility information element received from the calling party.

J.4 Low layer compatibility negotiation options

The Low layer compatibility information element contains a negotiation indicator which may have one of the following values:

- a) *Out-band negotiation not possible (default)* – Then the called user shall not invoke negotiation, according to J.3.
- b) *Out-band negotiation possible* – The called user may then invoke low layer compatibility negotiation, as needed, according to J.3.
- c) *In-band negotiation possible* – The called user may then invoke low layer compatibility negotiation using the supported in-band negotiation, according to service or application requirements.
- d) *Either in-band or out-band negotiation allowed* – The called user may invoke one or the other low layer compatibility negotiation procedures according to its requirements. If the call is end-to-end ISDN, and the out-band low layer compatibility negotiation is supported by both parties, then this method of negotiation is preferred.

J.5 Alternate requested values

If the user wishes to indicate alternative values of low layer compatibility parameters (e.g. alternative protocol suites or protocol parameters), the Low layer compatibility information element is repeated in the SETUP message. Up to four Low layer compatibility information elements may be included in a SETUP message. The first Low layer compatibility information element in the message is preceded by the Repeat indicator information element specifying “priority list for selection”. The order of appearance of the Low layer compatibility information elements indicates the order of preference of end-to-end low layer parameters.

Alternatively, the network may discard the lower priority Low layer compatibility information element(s) depending on the signalling capability of the network.

Superseded by a more recent version

If the network or called user does not support repeating of the Low layer compatibility information element, and therefore discards the Repeat indicator information element and the subsequent Low layer compatibility information elements, only the first Low layer compatibility information element is used in the negotiation.

The called user indicates a single choice from among the options offered in the SETUP message by including the Low layer compatibility information element in the CONNECT message. Absence of a Low layer compatibility information element in the CONNECT message indicates acceptance of the first Low layer compatibility information element in the SETUP message.

Annex K Procedures for establishment of bearer connection prior to call acceptance

(This annex forms an integral part of this Recommendation)

K.1 General

For some applications, it is desirable to allow the completion of the transmission path associated with a bearer service prior to receiving call acceptance. In particular, the completion of the backward direction of the transmission path prior to receipt of a CONNECT message from the called user may be desirable to

- a) allow the called user to provide internally-generated tones and announcements that are sent in-band to the calling user prior to answer by the called user; or
- b) avoid speech clipping on connections involving an NT2 where delays may occur in relaying the answer indication within the called user equipment.

The procedures described in this annex are only applicable to the speech and 3.1 kHz audio bearer services.

NOTE – The definition of necessary mechanisms (if any) with Signalling System No. 7 to avoid any potential undesirable charging implications remains for further study.

K.2 Procedures

As a network option, completion of the transmission path prior to receipt of a call acceptance indication may be provided in one of three ways:

- a) on completion of successful channel negotiation at the destination interface; or
- b) on receipt of a message containing an indication that in-band information is being provided; or
- c) not at all, i.e. this option is not supported by the network.

When criteria a) is used to determine that transmission path should be established, the network shall connect, as a minimum, the backward side of the transmission path upon receipt of either a CALL PROCEEDING message or an ALERTING message containing an acceptable B-channel indication.

When criteria b) is used to establish the transmission path, the network shall connect, as a minimum, the backward side of the transmission path upon receipt of either an ALERTING message or a PROGRESS message containing progress indicator No. 8, *in-band information or appropriate pattern now available*, or progress indicator No. 1, *call is not end-to-end ISDN; further call progress information may be available in-band*, respectively.

The network providing the early completion of the transmission path in the backward direction may choose to support only one of methods a) or b) above. The network may choose to further restrict which message(s) will result in establishment of the transmission path. These restrictions may be imposed on a per interface basis to provide an administrative means for limiting potential misuse of the early connection capabilities.

Superseded by a more recent version

Annex L

Optional procedures for bearer service change

(This annex forms an integral part of this Recommendation)

The procedure for bearer service change may not be provided on all networks. On those networks that support it, a user may use this procedure after making a suitable subscription-time arrangement.

When a bearer service requested in an originator's SETUP message cannot be provided by the network, the network would reject the call or, under some circumstances, the network may change the bearer service and provide bearer service change notification. These procedures are currently applicable only to a change from 64 kbit/s unrestricted to 64 kbit/s restricted, and from 64 kbit/s restricted to 64 kbit/s restricted with rate adaptation.

NOTE – During an interim period some networks may only support restricted 64 kbit/s digital information transfer capability, i.e. information transfer capability solely restricted by the requirement that the all-zero octet is not allowed. For interworking the values given in Appendix I/I.340 should apply. The interworking functions have to be provided in the network restricted capability. The ISDN with 64 kbit/s transfer capabilities will not be offered by this interworking, other than by conveying the appropriate signalling message to or from the ISDN terminal.

Up to two Bearer capability information elements may be present in the SETUP message from the originating user, corresponding to the allowed bearer service modifications given above. The Bearer capability information element shall be immediately preceded by the Repeat indicator information element with the meaning field specifying *Prioritized list for selecting one possibility*. Hence, the order of Bearer capability information elements would indicate order of bearer service preference.

If the SETUP message contains Bearer capability information elements not agreeing with any of the permissible ordered combinations listed above, the network will reject the call attempt.

After sending a CALL PROCEEDING message, when the originating network or terminating premises equipment determines that the preferred bearer service cannot be provided, it sends a NOTIFY message toward the call originator. The NOTIFY message contains a Notification indicator information element with a coding which indicates to the originating party the change in bearer service and also contains a Bearer capability information element specifying the attributes of the new bearer service.

Receipt of the NOTIFY message is not acknowledged. The call originator may allow the call to continue or may initiate call clearing in accordance with clause 5.

Superseded by a more recent version

Appendix I

Definition of causes values

(This appendix does not form an integral part of this Recommendation)

Table I.2 indicates the usage of cause values within this Recommendation. Other usage may be provided within other Recommendations, e.g. Q.700-Series and Q.699. Other causes may also be used by Q.931 entities where this is not precluded by the procedures defined elsewhere in this Recommendation.

Table I.1 defines the key for the location of generation in Table I.2. For more precise usage of the location codes in the cause information element, see Recommendation Q.850.

TABLE I.1/Q.931

Key to the location in Table I.2

LU	Local user
LN	Local network
TN	Transit network
RN	Remote network
RU	Remote user
LPE	Local peer entity (for symmetrical operation, see Annex D)
The following abbreviations to message types are used in Table I.2	
CON CON	CONGESTION CONTROL
DISC	DISCONNECT
REL	RELEASE
REL COM	RELEASE COMPLETE
RES REJ	RESUME REJECT
STAT	STATUS
SUSP REJ	SUSPEND REJECT

Superseded by a more recent version

TABLE I.2/Q.931

Usage of cause values

Cause No.	Class	Value	Cause name	Diagnostics	Reference	Typical location of generation	Typical carrying message as identified by receiving side	
							At remote interface	At local interface
1	000	0001	Unassigned (unallocated) number	Condition	5.1.4	LN		REL COM DISC
					5.2.4	RU	REL COM DISC	
2	000	0010	No route to specified transit network	Transit network identity/network specific facilities info. elements	C.2	TN		DISC
					E.3	LN		REL COM
3	000	0011	No route to destination	Condition	5.1.4	LN		DISC REL COM
					5.2.4	RU	REL COM DISC	DISC
6	000	0110	Channel unacceptable	–	5.2.3.1 c) 5.3.2 d) 6.2.2.3.1	LN		REL
7	000	0111	Call awarded and being delivered in an established channel	–	6.2.2.3.1	LN		REL
16	001	0000	Normal call clearing	Condition		RU	DISC	DISC
17	001	0001	User busy	–	5.2.5.1 5.2.5.4 b)	RU	REL COM	DISC
					No procedure	RN		DISC

Superseded by a more recent version

TABLE I.2/Q.931 (cont.)

Cause No.	Class	Value	Cause name	Diagnostics	Reference	Typical location of generation	Typical carrying message as identified by receiving side	
							At remote interface	At local interface
18	001	0010	No user responding	–	5.2.5.3	RN		DISC
19	001	0011	User alerting, no answer	–	5.2.5.3	RN		DISC
21	001	0101	Call rejected	Condition: user supplied diagnostic	5.2.5.1 5.2.5.4 b)	RU	REL COM	DISC
22	001	0110	Number changed	New destination number	5.1.4	LN		DISC REL COM
					5.2.4	RU	REL COM DISC	DISC
26	001	1010	Non-selected user clearing	–	5.3.2 b) 6.2.2.3.1	LN		REL
27	001	1011	Destination out of order	–	5.8.9	RN		DISC
28	001	1100	Invalid number format (incomplete number)	–		LN		DISC REL COM
					5.2.4	RU	DISC REL COM	DISC
					5.1.5.2	LN		DISC
					5.2.4	RN		DISC
					5.1.4	LN		DISC REL COM

Superseded by a more recent version

TABLE I.2/Q.931 (cont.)

Cause No.	Class	Value	Cause name	Diagnostics	Reference	Typical location of generation	Typical carrying message as identified by receiving side	
							At remote interface	At local interface
29	011	1101	Facility rejected	Facility identification	No procedure in Q.931	LN		REL COM DISC
						RN		DISC
						RU	REL COM DISC	
30	001	1110	Response to STATUS ENQUIRY	–	5.8.10	LU, LN		STAT
31	001	1111	Normal, unspecified	–	5.8.4	RN		REL COM DISC
34	010	0010	No circuit/channel available	–	5.1.1 5.1.2 5.1.5.1 5.1.5.2	LN		REL COM
					5.2.3.1 b) 5.2.3.1 e) 5.2.3.2 6.2.2.3.1	RU	REL COM	DISC
					C.2	LN	REL COM DISC	REL COM DISC
					C.2	TN		DISC
					D.1.1 e) D.3 b)	LPE		REL COM
38	010	0110	Network out of order	–	No procedure			

Superseded by a more recent version

TABLE I.2/Q.931 (cont.)

Cause No.	Class	Value	Cause name	Diagnostics	Reference	Typical location of generation	Typical carrying message as identified by receiving side	
							At remote interface	At local interface
41	010	1001	Temporary failure	–	5.8.8	LU, LN		DISC
					5.8.10	LN, RU, RN	DISC	DISC
42	010	1010	Switching equipment congestion	–	No procedure			REL REL COM
43	010	1011	Access information discarded	Discarded into element identifier(s)	7.1.5.7	RU, LN, RU		CON CON
					7.1.6.1	LN		STAT
					5.8.7.2	LN, LU		STAT
44	010	1100	Requested circuit/channel not available	–	5.1.2 5.1.5.1 5.1.5.2	LN		REL COM
					5.2.3.1 e) 5.2.3.2 6.2.3.3.1	RU	REL COM	DISC
					D.1.1 e)			REL COM
47	010	1111	Resource unavailable, unspecified	–	No procedure			

Superseded by a more recent version

TABLE I.2/Q.931 (cont.)

Cause No.	Class	Value	Cause name	Diagnostics	Reference	Typical location of generation	Typical carrying message as identified by receiving side	
							At remote interface	At local interface
57	011	1001	Bearer capability not authorized	Attributes of bearer capability	5.1.5.2	LN		DISC REL COM
					7.2.2	LN		REL REL COM
58	011	1010	Bearer capability not presently available	Attributes of bearer capability	5.1.5.2	LN		DISC REL COM
					7.2.2	LN		REL REL COM
63	011	1111	Service or option not available, unspecified	—	5.1.5.2	LN		DISC REL COM
65	100	0001	Bearer capability not implemented	Attributes of bearer capability	5.1.5.2	LN		DISC REL COM
					6.1	LN		REL COM
66	100	0010	Channel type not implemented	Channel type	No procedure			
69	100	0101	Requested facility not implemented	Facility identification	7.1.3.6	RU	DISC REL COM	DISC
					7.1.4.3 7.1.5.3	RN		REL DISC
					7.1.7.4	LN		REL REL COM

Superseded by a more recent version

TABLE I.2/Q.931 (cont.)

Cause No.	Class	Value	Cause name	Diagnostics	Reference	Typical location of generation	Typical carrying message as identified by receiving side	
							At remote interface	At local interface
70	100	0110	Only restricted digital information bearer capability is available	–	No procedure (network dependent option)			
79	100	1111	Service or option not implemented, unspecified					
81	101	0001	Invalid call reference value	–	5.8.3.2 a)	LU, LN		REL REL COM
					5.8.3.2 b)	LU, LN		REL COM
					5.8.3.2 f)	LU, LN		STAT
82	101	0010	Identified channel does not exist	Channel identity	5.1.4	LN		DISC REL COM
83	101	0011	A suspended call exists, but this call identity does not	–	5.6.5	LN		RES REJ
84	101	0100	Call identity in use	–	5.6.3	LN		SUSP REJ
85	101	0101	No call suspended	–	5.6.5	LN		RES REJ
86	101	0110	Call having the requested call identity has been cleared		5.6.5	LN		RES REJ

Superseded by a more recent version

TABLE I.2/Q.931 (cont.)

Cause No.	Class	Value	Cause name	Diagnostics	Reference	Typical location of generation	Typical carrying message as identified by receiving side	
							At remote interface	At local interface
88	101	1000	Incompatible destination	Incompatible parameter	5.2.2 5.2.5.1 5.2.5.3 a) B.3.2 B.3.3	RU	REL COM	DISC
91	101	1011	Invalid transit network selection	—	C.2	TN		DISC
						LN		DISC REL REL COM
95	101	1111	Invalid message, unspecified	Message type	5.8	LN		REL COM STAT
96	110	0000	Mandatory information element is missing	Information element identifier(s)	5.8.6.1	LN, LU		REL REL COM STAT
					5.8.11	LN, LU		STAT
97	110	0001	Message type non-existent or not implemented	Message type	5.8.4 5.8.10 5.8.11	LU, LN		STAT
98	110	0010	Message not compatible with call state or message type non-existent or not implemented	Message type	5.8.4	LU, LN		STAT
99	110	0011	Information element non-existent or not implemented	Information element identifier(s)	5.8.7.1 5.8.11	LU, LN		STAT
					5.8.7.1	LN		REL REL COM

Superseded by a more recent version

TABLE I.2/Q.931 (end)

Cause No.	Class	Value	Cause name	Diagnostics	Reference	Typical location of generation	Typical carrying message as identified by receiving side	
							At remote interface	At local interface
100	110	0100	Invalid information element contents	Information element identifier(s)	5.8.6.2	LU, LN		STAT REL REL COM
					5.8.7.2 5.8.11	LU, LN		STAT
101	110	0101	Message not compatible with call state	Message type	5.8.4	LN, LU		STAT
					5.8.11	LN, LU		DISC REL REL COM
102	110	0110	Recovery on time expiry	Timer number	5.2.4 5.2.5.3 5.6.5 5.4.1	LN		DISC
					5.3.3 5.3.4	LN		REL
					5.3.2 f) 5.3.3 5.6.5	LU		REL
111	110	1111	Protocol error, unspecified		5.8.4	RN		DISC
127	111	1111	Interworking, unspecified		No explicit procedure			

Superseded by a more recent version

Appendix II

Example message flow diagrams and example conditions for cause mapping

(This appendix does not form an integral part of this Recommendation)

II.1 Example message flow diagrams

Examples of the procedures for the use of the B- and D-channel network connection types and the selection of the appropriate channel types are summarized in Figures II.1 to II.7. These figures are intended to complement the description in the preceding text and do not illustrate all possible situations.

NOTE – Not all frames that may be sent across the TA interface may be represented in the following figures.

II.1.1 Key to the figures

Q.931 messages

[]	Layer 3
C	CONNECT
CA	CONNECT ACKNOWLEDGE
CP	CALL PROCEEDING
D	DISCONNECT
R	RELEASE
RC	RELEASE COMPLETE
S	SETUP

X.25 layer 3 messages

Any layer 3 message preceded by X.25 indicates an X.25 layer 3 packet (e.g. X.25 CR means X.25 *call request*).

CA	Call accepted
CC	Call connected
CLC	Clear confirmation
CLI	Clear indication
CLR	Clear request
CR	Call request
IC	Incoming call
SQ	Restart request
SF	Restart confirmation
SI	Restart indication

Superseded by a more recent version

Layer 2 frames

()	Layer 2
GTEI	Group TEI (127)
A.B	X.25 layer 2 addresses (includes command and response)
SABM	Set asynchronous balance mode
SABME	Set asynchronous balance mode extended
UA	Unnumbered acknowledgement frame
UI	Unnumbered information frame (i.e. using unacknowledged information transfer at layer 2)
I	Information frame
DISC	Disconnect frame

Layer 2 addresses marked (x, p) indicates that the SAPI element of the frame address is coded for packet type (SAPI = 16) information as described in Recommendation Q.921. Layer 2 addresses marked (x, s) refer to signalling type (SAPI = 0) information.

II.2 Example conditions for cause mapping

Figures II.8 through II.16 show example conditions when cause mappings would be utilized between Q.931 and X.25 messages and utilize the specific mappings of Table 6-5 and Table 6-6 as shown below.

Figure Reference Table

Q.931 failures during call establishment

II.8 Table 6-5

II.9 Table 6-5

II.10 Table 6-5

II.11 Table 6-5

II.12 Table 6-5

User side failures during X.25 data transfer phase

II.13 Table 6-5 (Note 1)

II.14 Table 6-5 (Note 2)

Network side premature clearing

II.15 Table 6-6

II.16 Table 6-6

NOTES

1 This mapping is only needed in the case of the Q.931 message arriving prior to the clearing of the last virtual call.

2 This situation always results in either an X.25 *clear indication* packet with cause No. 9, *out of order* for switched virtual calls, or an X.25 *reset* packet with cause No. 9, *out of order* for permanent virtual circuits.

Superseded by a more recent version

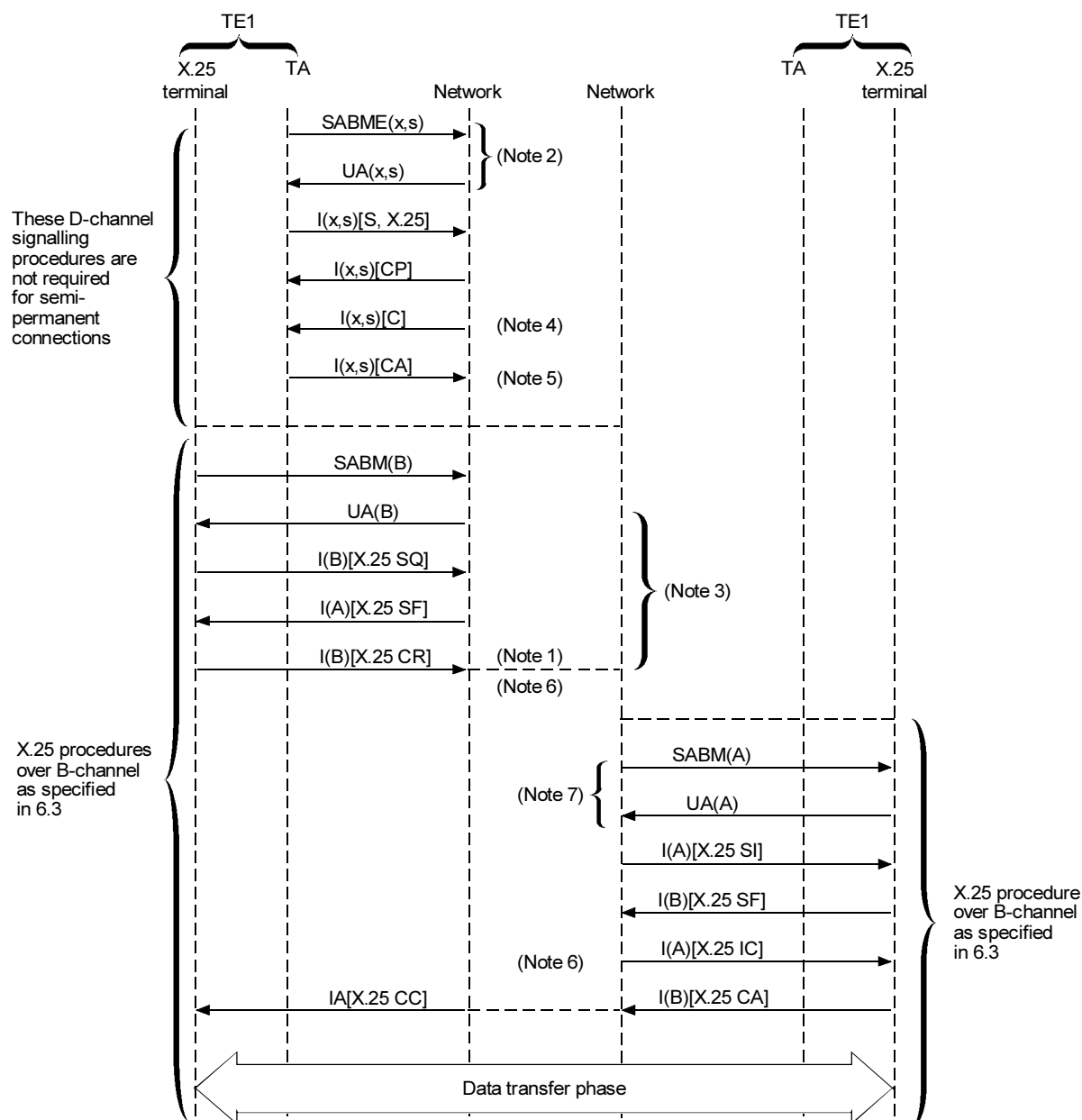

T1137000-91/d097

NOTES

- 1 When the called side establishes the call using D-channel access, the message sequence will continue as from point <3> in Figure II.3.
- 2 If signalling link is not already established.
- 3 For packet call offering, the incoming call may be offered to the TA and a B-channel established using the procedure shown in Figures II.5 and II.7.
- 4 The network starts timer T320, if implemented.
- 5 This message is optional.
- 6 The network cancels timer T320, if implemented and running.
- 7 The network establishes the Link Layer on the B-channel, if it is not already established as specified in 6.3.

FIGURE II.1/Q.931

Example message sequence for the ISDN virtual circuit service
B-channel access – First virtual call set-up in this channel

Superseded by a more recent version

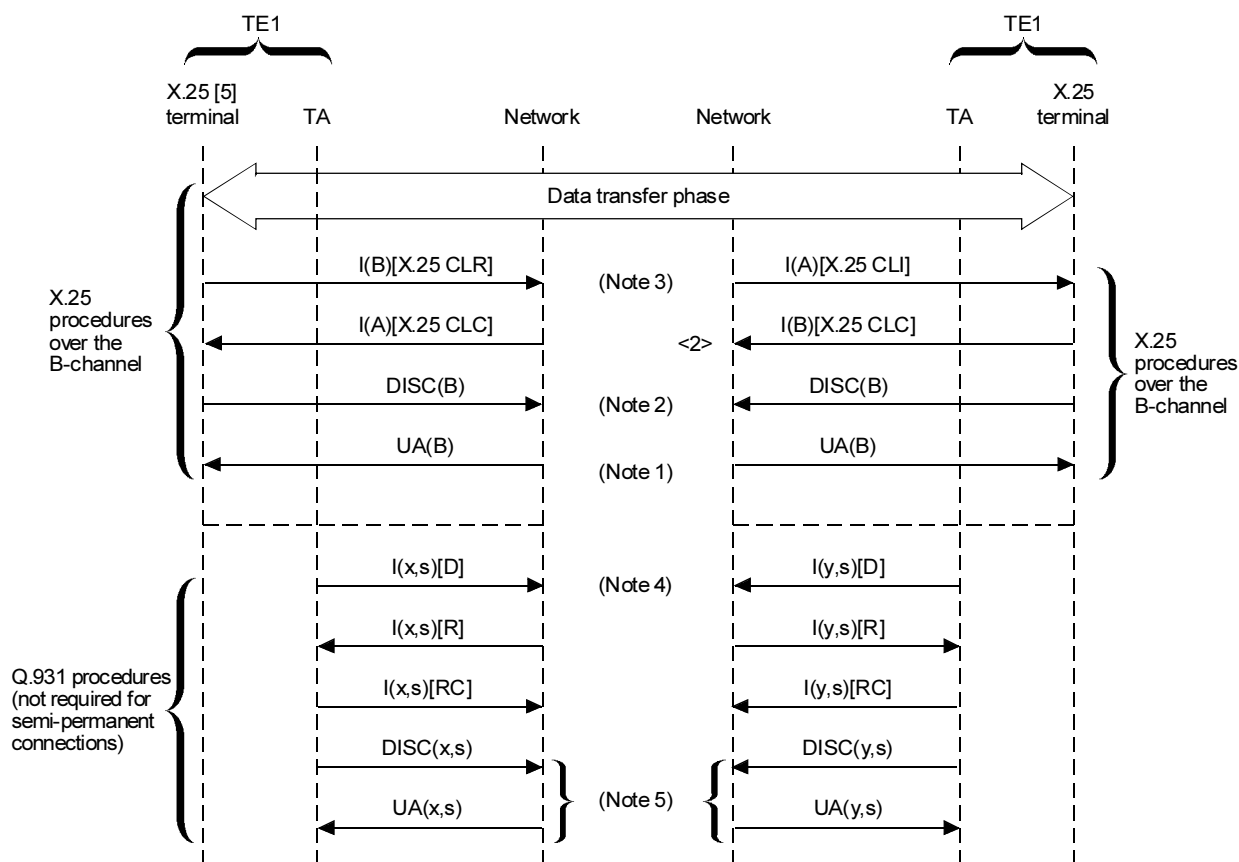

T1161250-94/d098

NOTES

- When the cleared side has set up the call using D-channel access, the message sequence at the cleared side will be as from point <4> in Figure II.4.
- Clearing of the B-channel may be initiated by the network upon expiry of Timer T320, if implemented (see 6.4).
- The network starts Timer T320, if implemented.
- The network cancels Timer T320, if implemented and running.
- This sequence is only required if the terminal does not wish to continue with further communication.

FIGURE II.2/Q.931

**Example message sequence for the ISDN virtual circuit service
B-channel access – Last virtual call cleared in this channel**

Superseded by a more recent version

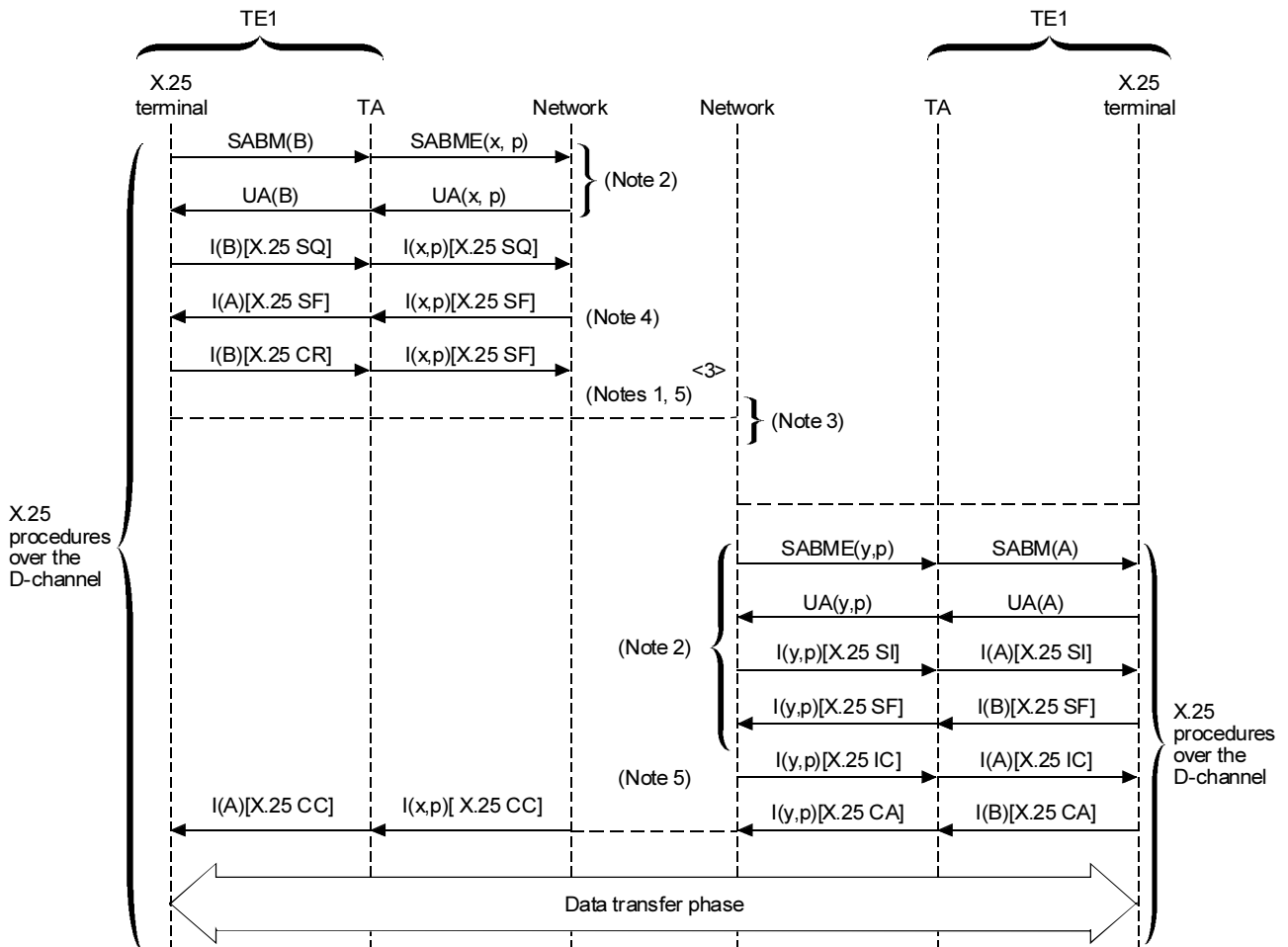

T1137010-91/d099

NOTES

- 1 When the called side establishes the call using B-channel access, the message sequence will continue as from point <1> in Figure II.1.
- 2 If SAPI 16 link is not already established.
- 3 The incoming call may be offered to the TA using the procedures shown in Figures II.5 and II.7.
- 4 The network starts timer T320, if implemented.
- 5 The network cancels timer T320, if implemented and running.
- 6 Not shown in the diagram; is a possible X.25 restart procedure performed after link set-up.

FIGURE II.3/Q.931

**Example message sequence for the ISDN virtual circuit service
D-channel access – First virtual call set-up in this SAPI = 16 link**

Superseded by a more recent version

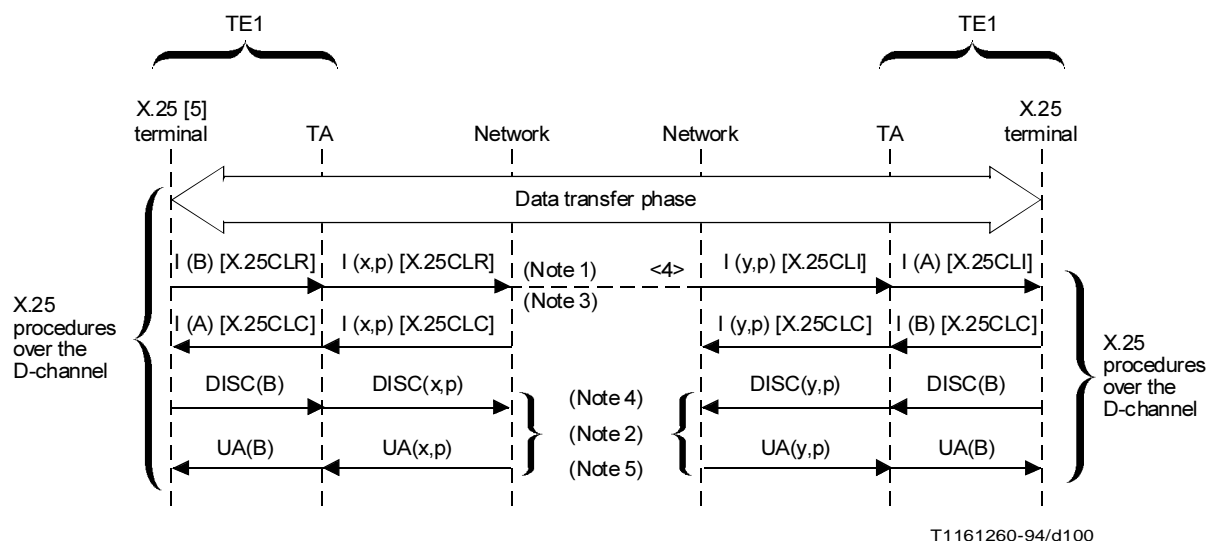

T1161260-94/d100

NOTES

- 1 When the cleared side has set up the call using B-channel access, the message sequence at the cleared side will be as from point <2> in Figure II.2.
- 2 This sequence is only required if the X.25 DTE does not wish to continue with further communications.
- 3 The network starts timer T320, if implemented.
- 4 The network cancels timer T320, if implemented and running.
- 5 Link layer release may be initiated by the network upon expiry of Timer T320, if implemented (see 6.4).

FIGURE II.4/Q.931

**Example message sequence for the ISDN virtual circuit service
D-channel access – Last virtual call cleared in this SAPI = 16 link**

Superseded by a more recent version

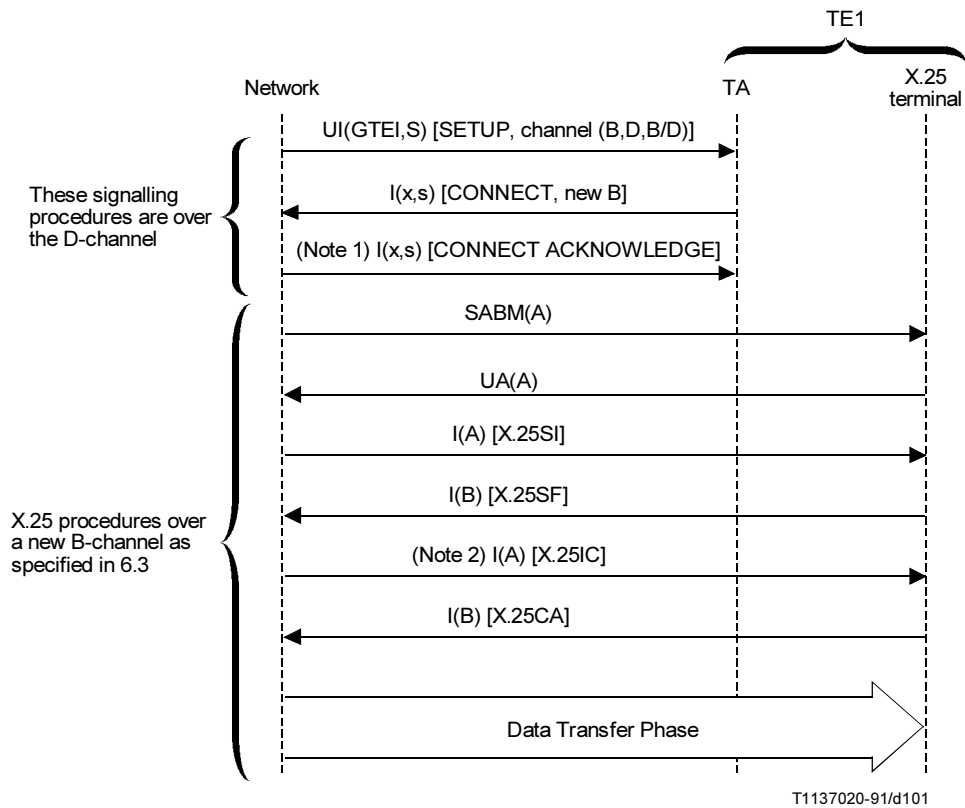

NOTES

- 1 The network starts Timer T320, if implemented.
- 2 The network cancels Timer T320, if implemented and running.

FIGURE II.5/Q.931

Example of incoming call offering procedures using signalling on SAPI = 0 link – Terminal accepts call on a new B-channel

Superseded by a more recent version

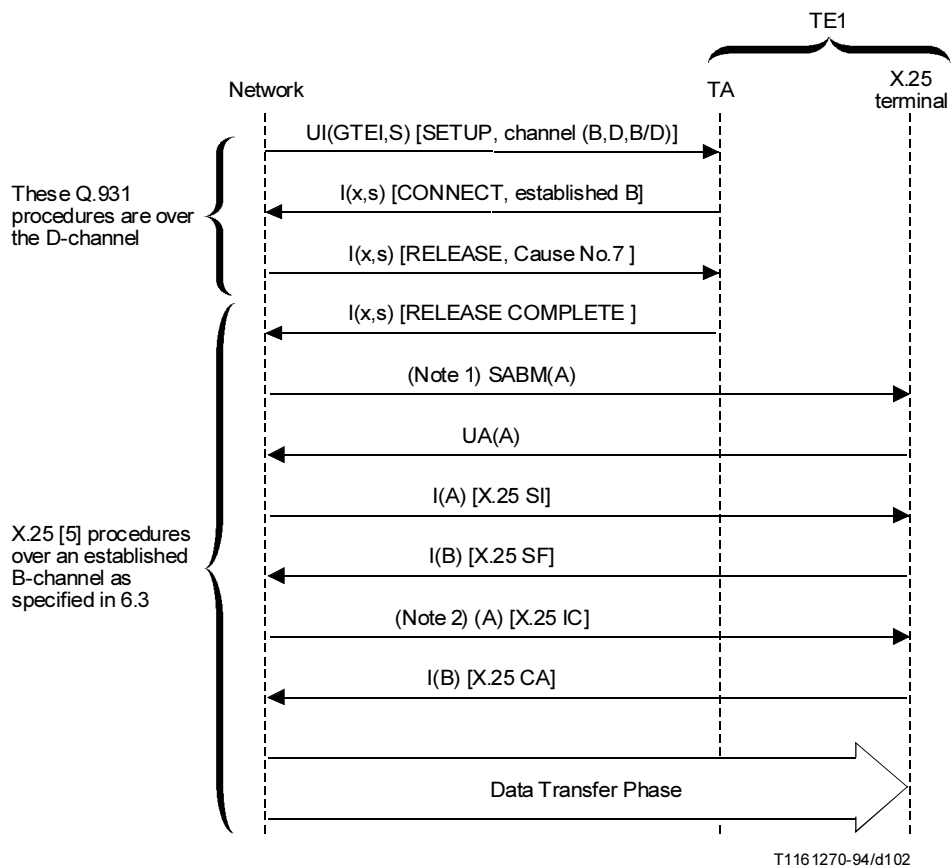

NOTES

- 1 The network establishes the link layer in the B-channel if it is not already established (see 6.3).
- 2 The network cancels Timer T320, if implemented and running.

FIGURE II.6/Q.931

Example of incoming call offering procedures using signalling on SAPI = 0 link – Terminal accepts call on a established B-channel

Superseded by a more recent version

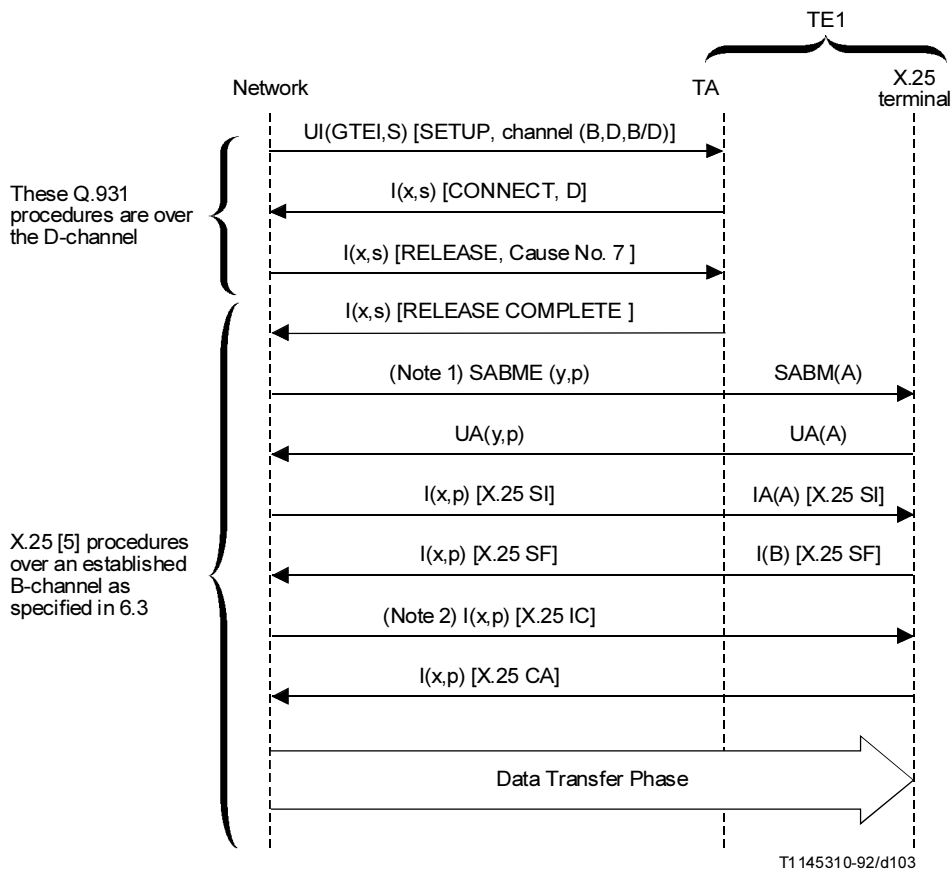

NOTES

- 1 The network establishes the link layer in the B-channel if it is not already established (see 6.3). The network starts Timer T320, if implemented.
- 2 The network cancels Timer T320, if implemented and running.

FIGURE II.7/Q.931

Example of incoming call offering procedures using signalling on SAPI = 0 link – Terminal accepts call on the D-channel

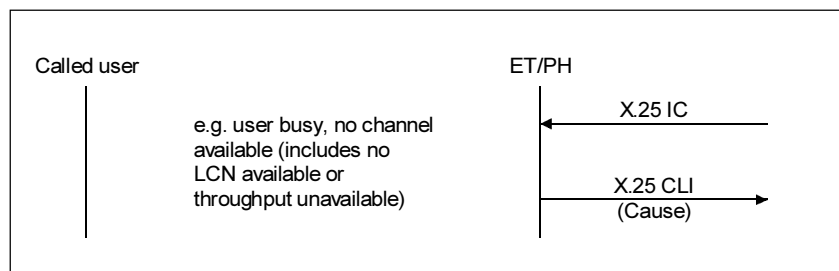
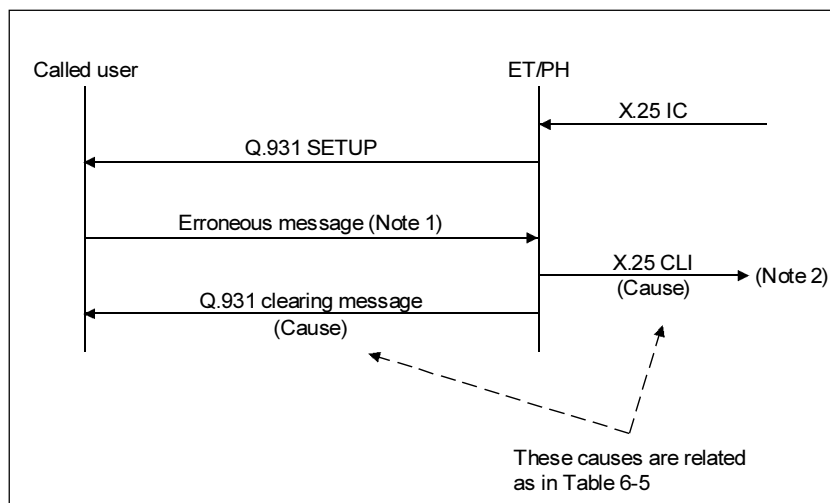

FIGURE II.8/Q.931

Undeliverable call

Superseded by a more recent version



T1161290-94/d105

NOTES

1 This figure only applies to the case where the erroneous message results in a Q.931 clearing message. See 6.4.3 for more information.

2 This message would be sent after the expiry of timer T303 on a multipoint interface.

FIGURE II.9/Q.931
Erroneous message (e.g. format error)

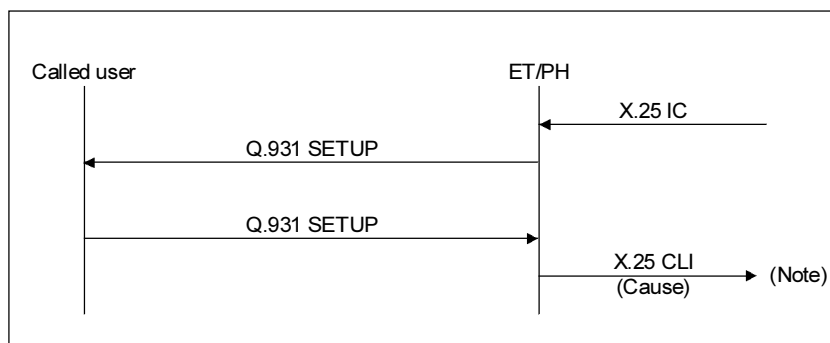

T1161300-94/d106

NOTE – This message is sent after the second expiry of timer T303.

FIGURE II.10/Q.931
No responding user

Superseded by a more recent version

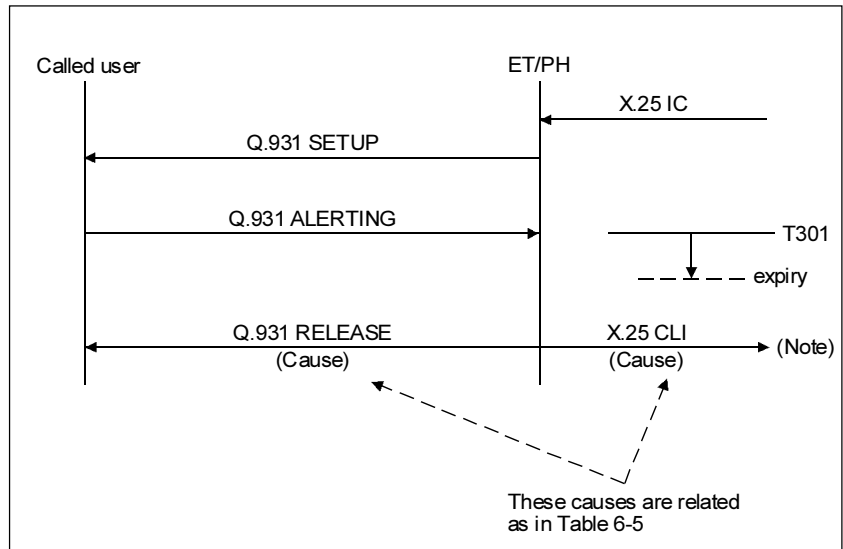

T1161310-94/d107

NOTE – This message is sent after the expiry of timer T301.

FIGURE II.11/Q.931

Expiry of timer T301

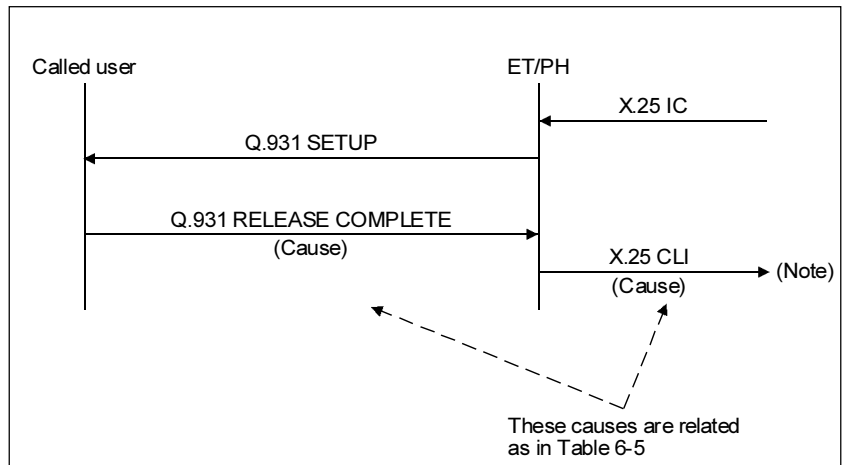

T1161320-94/d108

NOTE – This message would be sent after the expiry of T303 when on a multipoint interface.

FIGURE II.12/Q.931

Call rejection by called party

Superseded by a more recent version

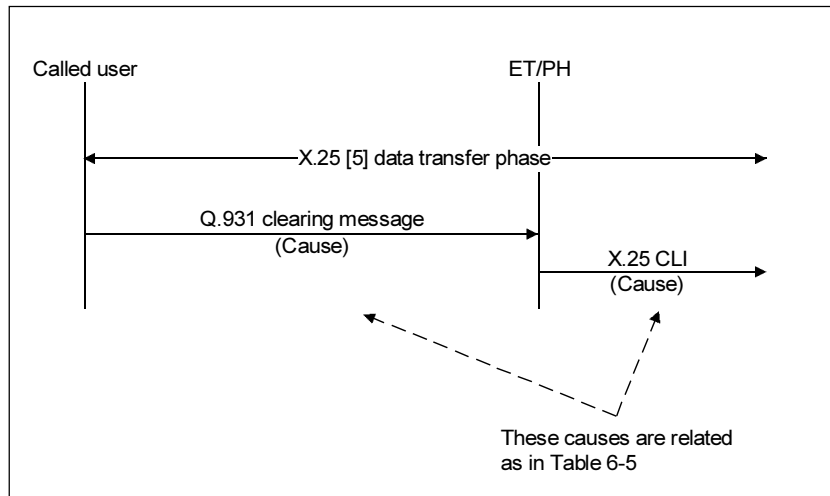

T1161330-94/d109

FIGURE II.13/Q.931
Q.931 clearing during X.25 data transfer phase

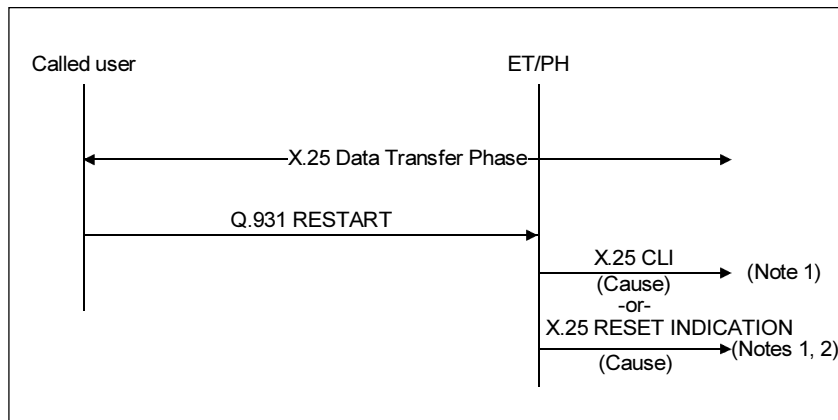

T1161340-94/d110

NOTES

- 1 This cause parameter in the X.25 packet will indicate "out of order" with diagnostic value 0.
- 2 For permanent virtual circuits only.

FIGURE II.14/Q.931
Q.931 RESTART during X.25 data transfer phase

Superseded by a more recent version

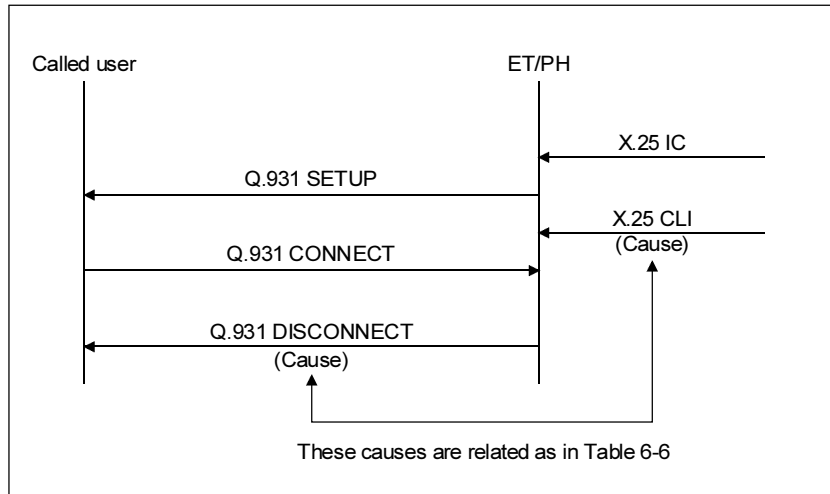

T1161350-94/d111

FIGURE II.15/Q.931

**Premature clearing of the virtual call
(e.g. expiry of X.25 Timer T21)**

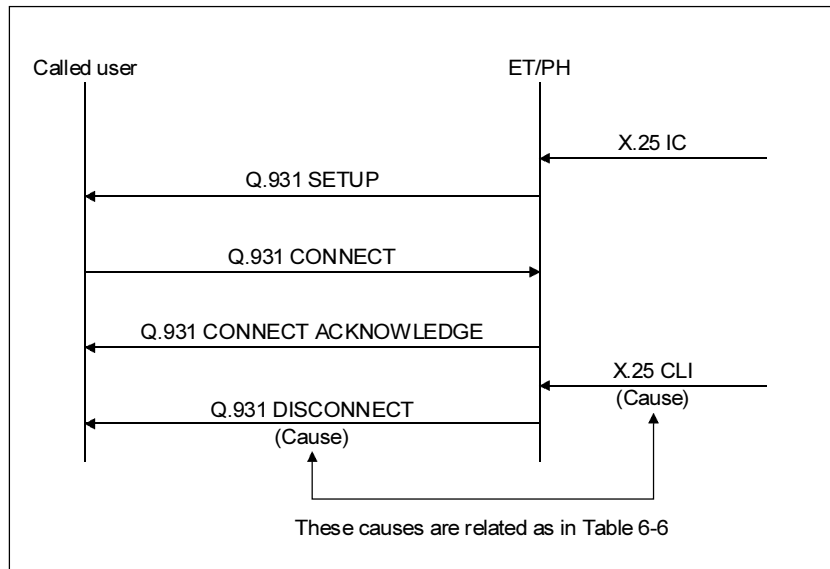

T1161360-94/d112

NOTE – This is the case when an X.25 incoming call packet has NOT been delivered.

FIGURE II.16/Q.931

Premature clearing of the virtual call

Superseded by a more recent version

Appendix III

Summary of assigned information element identifier and message type code points for the Q.93x-Series and Q.95x-Series of Recommendations

(This appendix does not form an integral part of this Recommendation)

TABLE III.1/Q.931

Information element code points

Bits								Recommendation reference
8	7	6	5	4	3	2	1	
1	:	:	:	-	-	-	-	<i>Single octet information elements:</i>
0	0	0	-	-	-	-	-	Reserved Q.931
0	0	1	-	-	-	-	-	Shift Q.931
0	1	0	0	0	0	0	0	More data Q.931
0	1	0	0	0	0	0	1	Sending complete Q.931
0	1	1	-	-	-	-	-	Congestion level Q.931
1	0	1	-	-	-	-	-	Repeat indicator Q.931
0	:	:	:	:	:	:	:	<i>Variable length information elements:</i>
0	0	0	0	0	0	0	0	Segmented message Q.931
0	0	0	0	1	0	0	0	Bearer capability Q.931
0	0	0	1	0	0	0	0	Cause Q.931
0	0	0	1	1	0	0	0	Connected address (Note 1) Q.931
0	0	0	1	1	0	1	1	Extended facility Q.932
0	0	1	0	0	0	0	0	Call identity Q.931
0	0	1	0	1	0	0	0	Call state Q.931
0	0	1	1	0	0	0	0	Channel identification Q.931
0	0	1	1	0	0	1	1	Data link connection identifier Q.933
0	0	1	1	1	0	0	0	Facility Q.932
0	0	1	1	1	1	1	0	Progress indicator Q.931
0	1	0	0	0	0	0	0	Network specific facilities Q.931
0	1	0	0	1	0	0	0	Terminal capabilities (Note 1) Q.931
0	1	0	0	1	1	1	1	Notification indicator Q.931
0	1	0	1	0	0	0	0	Display Q.931
0	1	0	1	0	0	1	1	Date/time Q.931
0	1	0	1	1	0	0	0	Keypad facility Q.931
0	1	1	0	0	0	0	0	Keypad echo (Note 1) Q.931
0	1	1	0	0	1	0	0	Information request Q.932 [4]
0	1	1	0	1	0	0	0	Signal Q.931
0	1	1	0	1	1	0	0	Switchhook (Note 1) Q.931
0	1	1	1	0	0	0	0	Feature activation Q.932
0	1	1	1	0	0	1	1	Feature indication Q.932
0	1	1	1	0	1	0	0	Service profile identification Q.932
0	1	1	1	0	1	1	1	Endpoint identifier Q.932
1	0	0	0	0	0	0	0	Information rate Q.931
1	0	0	0	0	0	1	1	Precedence level Q.955 (clause 3)
1	0	0	0	0	1	0	0	End-to-end transit delay Q.931
1	0	0	0	0	1	1	1	Transit delay selection and indication Q.931
1	0	0	0	1	0	0	0	Packet layer binary parameters Q.931
1	0	0	0	1	0	1	1	Packet layer window size Q.931

Superseded by a more recent version

TABLE III.1/Q.931 (*end*)

Bits								Recommendation reference	
8	7	6	5	4	3	2	1		
0	:	:	:	:	:	:	:	<i>Variable length information elements:</i>	
1	0	0	0	1	1	0		Packet size	Q.931
1	0	0	0	1	1	1		Closed user group	Q.931
1	0	0	1	0	0	0		Link layer core parameters	Q.933
1	0	0	1	0	0	1		Link layer protocol parameters	Q.933
1	0	0	1	0	1	0		Reverse charging indication	Q.931
1	0	0	1	1	0	0		Connected number	Q.951 [85]
1	0	0	1	1	0	1		Connected subaddress	Q.951
1	0	1	0	0	0	0		X.213 priority	Q.933
1	0	1	0	0	0	1		Report type	Q.933
1	0	1	0	0	1	1		Link integrity verification	Q.933
1	0	1	0	1	1	1		PVC status	Q.933
1	1	0	1	1	0	0		Calling party number	Q.931
1	1	0	1	1	0	1		Calling party subaddress	Q.931
1	1	1	0	0	0	0		Called party number	Q.931
1	1	1	0	0	0	1		Called party subaddress	Q.931
1	1	1	0	1	0	0		Redirecting number	Q.931, Q.952 [86]
1	1	1	0	1	1	0		Redirection number	Q.952
1	1	1	1	0	0	0		Transit network selection	Q.931
1	1	1	1	0	0	1		Restart indicator	Q.931
1	1	1	1	1	0	0		Low layer compatibility	Q.931
1	1	1	1	1	0	1		High layer compatibility	Q.931
1	1	1	1	1	1	0		User-user	Q.931
1	1	1	1	1	1	1		Escape for extension	Q.931

NOTES

1 These code points are reserved to ensure backward compatibility with earlier versions of this Recommendation.

2 All reserved values with bits 5-8 coded "0000" are for future information elements for which comprehension by the user is required (see 5.8.7.1).

Superseded by a more recent version

TABLE III.2/Q.931

Message type code points

Bits								Recommendation reference	
8	7	6	5	4	3	2	1		
0	0	0	0	0	0	0	0	Escape to nationally specific message types	Q.931
0	0	0	-	-	-	-	-	<i>Call establishment messages:</i>	
			0	0	0	0	1	ALERTING	Q.931
			0	0	0	1	0	CALL PROCEEDING	Q.931
			0	0	0	1	1	PROGRESS	Q.931
			0	0	1	0	1	SETUP	Q.931
			0	0	1	1	1	CONNECT	Q.931
			0	1	1	0	1	SETUP ACKNOWLEDGE	Q.931
			0	1	1	1	1	CONNECT ACKNOWLEDGE	Q.931
0	0	1	-	-	-	-	-	<i>Call information phase messages:</i>	
			0	0	0	0	0	USER INFORMATION	Q.931
			0	0	0	0	1	SUSPEND REJECT	Q.931
			0	0	0	1	0	RESUME REJECT	Q.931
			0	0	1	0	0	HOLD	Q.932 [4]
			0	0	1	0	1	SUSPEND	Q.931
			0	0	1	1	0	RESUME	Q.931
			0	1	0	0	0	HOLD ACKNOWLEDGE	Q.932
			0	1	1	0	1	SUSPEND ACKNOWLEDGE	Q.931
			0	1	1	1	0	RESUME ACKNOWLEDGE	Q.931
			1	0	0	0	0	HOLD REJECT	Q.932
			1	0	0	0	1	RETRIEVE	Q.932
			1	0	0	1	1	RETRIEVE ACKNOWLEDGE	Q.932
			1	0	1	1	1	RETRIEVE REJECT	Q.932
0	1	0	-	-	-	-	-	<i>Call clearing messages:</i>	
			0	0	0	0	0	DETACH	(Note)
			0	0	1	0	1	DISCONNECT	Q.931
			0	0	1	1	0	RESTART	Q.931
			0	1	0	0	0	DETACH ACKNOWLEDGE	(Note)
			0	1	1	0	1	RELEASE	Q.931
			0	1	1	1	0	RESTART ACKNOWLEDGE	Q.931
			1	1	0	1	0	RELEASE COMPLETE	Q.931
0	1	1	-	-	-	-	-	<i>Miscellaneous messages:</i>	
			0	0	0	0	0	SEGMENT	Q.931
			0	0	0	1	0	FACILITY	Q.932 [4]
			0	0	1	0	0	REGISTER	Q.932
			0	1	0	0	0	CANCEL ACKNOWLEDGE	(Note)
			0	1	0	1	0	FACILITY ACKNOWLEDGE	(Note)
			0	1	1	0	0	REGISTER ACKNOWLEDGE	(Note)
			0	1	1	1	0	NOTIFY	Q.931
			1	0	0	0	0	CANCEL REJECT	(Note)
			1	0	0	1	0	FACILITY REJECT	(Note)
			1	0	1	0	0	REGISTER REJECT	(Note)
			1	0	1	0	1	STATUS ENQUIRY	Q.931
			1	1	0	0	1	CONGESTION CONTROL	Q.931
			1	1	0	1	1	INFORMATION	Q.931
			1	1	1	0	1	STATUS	Q.931

NOTE – These code points are reserved to ensure backward compatibility with earlier versions of this Recommendation.

Superseded by a more recent version

ACRONYMS USED IN THIS RECOMMENDATION

ABM	Asynchronous Balanced Mode (of HDLC)
ACK	Acknowledgement
ADPCM	Adaptive Differential Pulse Code Modulation
AFI	Authority and Format Identifier
ARM	Asynchronous Response Mode (of HDLC)
AU	Access Unit
BC	Bearer Capability
BCD	Binary Coded Decimal
Bi	Indicated B-Channel
Bi'	An idle B-Channel Bi
Bj	A B-Channel in use
CEI	Connection Endpoint Identifier
CES	Connection Endpoint Suffix
CSPDN	Circuit Switched Public Data Network
D	The D-Channel
DDI	Direct-Dialling-In
DLCI	Data Link Connection Identifier (see Recommendations Q.920 and Q.921)
DSP	Domain Specific Part
DTE	Data Terminal Equipment
HDLC	High Level Data Link Control (procedures)
HLC	High Layer Compatibility
I	Information (frame)
IA5	International Alphabet No. 5 (defined by CCITT)
IDI	Initial Domain Identifier
IE	Information Element
IEC	International Electrotechnical Commission
ISDN	Integrated Services Digital Network
ISO	International Standard Organization
IWF	Interworking Function
IWU	Interworking Unit
LAN	Local Area Network
LAPB	Link Access Protocol-Balanced
LAPD	Link Access Protocol on the D-Channel
LLC	Low Layer Compatibility

Superseded by a more recent version

LLI	Logical Link Identifier (see Recommendation Q.921)
NACK	Negative Acknowledgement
NIC	Network Independent Clock
NRM	Normal Response Mode (of HDLC)
NSAP	Network Service Access Point
NT2	Network Termination of type two
OSI	Open System Interconnection
PABX	Private Automatic Branch Exchange
PCM	Pulse Code Modulation
PH	Packet Handler
PSPDN	Packet Switched Public Data Network
PSTN	Public Switched Telephony Network
PVC	Permanent Virtual Circuit
RDTD	Restricted Differential Time Delay
SABME	Set Asynchronous Balanced Mode Extended (frame)
SAPI	Service Access Point Identifier (see Recommendation Q.921)
SDL	Functional specification and description language
TA	Terminal Adaptor (see Recommendation I.411)
TE1	Terminal Equipment of type 1 (see Recommendation I.411)
TE2	Terminal Equipment of type 2 (see Recommendation I.411)
TEI	Terminal Endpoint Identifier (see Recommendations Q.920 and Q.921)
TID	Terminal identifier
UDI	Unrestricted Digital Information
UDI-TA	Unrestricted Digital Information with Tones/Announcements
UI	Unnumbered Information (frame)
USID	User service identifier
VC	(Switched) Virtual Circuit

References

- [1] CCITT Recommendation *ISDN user-network interface layer 3 – General aspects*, Rec. Q.930/I.450.
- [2] CCITT Recommendation *ISDN user-network interface – Interface structures and access capabilities*, Rec. I.412.
- [3] CCITT Recommendation *ISDN user-network interface – Data link layer specification*, Rec. Q.921/I.441.
- [4] CCITT Recommendation *Generic procedures for the control of ISDN supplementary services*, Rec. Q.932.

Superseded by a more recent version

- [5] CCITT Recommendation *Interface between data terminal equipment (DTE) and data circuit terminating equipment (DCE) for terminals operating in the packet mode and connected to public data networks by dedicated circuit*, Rec. X.25.
- [6] CCITT Recommendation *Circuit mode bearer service categories*, Rec. I.231.
- [7] CCITT Recommendation *Support of data terminal equipments (DTEs) with V-Series type interfaces by an integrated services digital network (ISDN)*, Rec. V.110.
- [8] CCITT Recommendation *Support of X.21, X.21 bis and X.20 bis based data terminal equipments (DTEs) by an integrated services digital network (ISDN)*, Rec. X.30.
- [9] CCITT Recommendation *Support by an ISDN of data terminal equipment with V-Series type interfaces with provision for statistical multiplexing*, Rec. V.120.
- [10] CCITT Recommendation *Pulse code modulation (PCM) of voice frequencies*, Rec. G.711.
- [11] CCITT Recommendation *32 kbit/s adaptive differential pulse code modulation (ADPCM)*, Rec. G.721.
- [12] CCITT Recommendation *7 kHz audio coding within 64 kbit/s*, Rec. G.722.
- [13] CCITT Recommendation *Codec for audiovisual services AT $n \times 384$ kbit/s*, Rec. H.261.
- [14] CCITT Recommendation *Support of packet mode terminal equipment by an ISDN*, Rec. X.31.
- [15] CCITT Recommendation *Multiplexing rate adaption and support of existing interfaces*, Rec. I.460.
- [16] CCITT Recommendation *Standardization of data signalling rates for synchronous data transmission on leased telephone-type circuits*, Rec. V.6.
- [17] CCITT Recommendation *International user classes of service in public data networks and integrated services digital networks (ISDNs)*, Rec. X.1.
- [18] CCITT Recommendation *ISDN numbering and addressing principles*, Rec. I.330.
- [19] CCITT Recommendation *Numbering plan for the ISDN era*, Rec. E.164.
- [20] CCITT Recommendation *Numbering plan for the international telephone service*, Rec. E.163.
- [21] CCITT Recommendation *International numbering plan for public data networks*, Rec. X.121.
- [22] CCITT Recommendation *Plan for telex destination codes*, Rec. F.69.
- [23] CCITT Recommendation *Network service definition for Open Systems Interconnection (OSI) for CCITT applications*, Rec. X.213.
- [24] ISO 8348:1987/Add.2:1988 *Information processing systems – Data communications – Network service definition – Addendum 2: Network layer addressing*.
- [25] CCITT Recommendation *Principles relating ISDN numbers/subaddress to the OSI reference model network layer addresses*, Rec. I.334.
- [26] CCITT Recommendation *Interface between data terminal equipment (DTE) and data circuit-terminating equipment (DCE) for synchronous operation on public data networks*, Rec. X.21.
- [27] CCITT Recommendation *Primary rate user-network interface – Layer 1 specification*, Rec. I.431.
- [28] CCITT Recommendation *Control procedures for teletex and Group 4 facsimile services*, Rec. T.62.
- [29] CCITT Recommendation *A document application profile for the interchange of Group 4 facsimile documents*, Rec. T.503.
- [30] CCITT Recommendation *A document application profile MM for the interchange of formatted mixed mode documents*, Rec. T.501.

Superseded by a more recent version

- [31] CCITT Recommendation *Document application profile PMI for the interchange of processable form documents*, Rec. T.502.
- [32] CCITT Recommendation *Network-independent basic transport service for the telematic services*, Rec. T.70.
- [33] CCITT Recommendation *Document application profile for videotex interworking*, Rec. T.504.
- [34] CCITT Recommendation *Teleservices supported by an ISDN*, Rec. I.241.
- [35] CCITT Recommendation *System aspects of the use of the 7 kHz audio codec within 64 kbit/s*, Rec. G.725.
- [36] ISO 1745:1975 *Information processing – Basic mode control procedures for data communication systems*.
- [37] CCITT Recommendation *Link access protocol balanced (LAPB) extended for half-duplex physical level facility*, Rec. T.71.
- [38] ISO/IEC 4335:1991 *Information technology – Telecommunications and information exchange between systems – High-level data link control (HDLC) procedures – Elements of procedures*.
- [39] ISO 8802-2:1989 *Information processing systems – Local area networks – Part 2: Logical link control*.
- [40] CCITT Recommendation *Packet switched signalling system between public networks providing data transmission services*, Rec. X.75.
- [41] ISO/IEC 8208:1990 *Information technology – Data communications – X.25 Packet layer Protocol for data terminal equipment*.
- [42] ISO 8348:1987 *Information processing systems – Data communications – Network service definition*.
- [43] ISO 8473:1988 *Information processing systems – Data communications – Protocol for providing the connectionless-mode network service*.
- [44] CCITT Recommendation *Procedure for the exchange of protocol identification during virtual call establishment on packet switched public data networks*, Rec. X.244.
- [45] CCITT Recommendation *ISDN user-network interface data link layer – General aspects*, Rec. Q.920/I.440.
- [46] CCITT Recommendation *Basic user-network interface – Layer 1 specification*, Rec. I.430.
- [47] CCITT Recommendation *Definition of bearer service categories*, Rec. I.230.
- [48] CCITT Recommendation *Definition of teleservices*, Rec. I.240.
- [49] CCITT Recommendation *International Alphabet No. 5*, Rec. T.50.
- [50] ISO 646 *Information processing – ISO 7-bit coded character set for information interchange*.
- [51] CCITT Recommendations *on Integrated services digital network (ISDN)*.
- [52] CCITT Recommendation *Support of data terminal equipments (DTEs) with V-Series type interfaces by an integrated services digital network (ISDN)*, Rec. I.463.
- [53] CCITT Recommendation, *Blue Book* Vol. VI, Rec. Q.931 (1988).
- [54] CCITT Recommendation *Stage 3 description for additional information transfer supplementary services using DSSI*, Rec. Q.957.
- [55] CCITT Recommendation *300 bits per second duplex modem standardized for use in the general switched telephone network*, Rec. V.21.
- [56] CCITT Recommendation *1200 bits per second duplex modem standardized for use in the general switched telephone network and on point-to-point 2-wire leased telephone-type circuits*, Rec. V.22.

Superseded by a more recent version

- [57] CCITT Recommendation *2400 bits per second duplex modem using frequency division technique standardized for use in the general switched telephone network and on point-to-point 2-wire leased telephone-type circuits*, Rec. V.22 bis.
- [58] CCITT Recommendation *600/1200-baud modem standardized for use in the general switched telephone network*, Rec. V.23.
- [59] CCITT Recommendation *2400 bits per second modem standardized for use on 4-wire leased telephone-type circuits*, Rec. V.26.
- [60] CCITT Recommendation *2400/1200 bits per second modem standardized for use in the general switched telephone network*, Rec. V.26 bis.
- [61] CCITT Recommendation *2400 bits per second duplex modem using the echo cancellation technique standardized for use on the general switched telephone network and on point-to-point 2-wire leased telephone type circuits*, Rec. V.26 ter.
- [62] CCITT Recommendation *4800 bits per second modem with manual equalizer standardized for use on leased telephone-type circuits*, Rec. V.27.
- [63] CCITT Recommendation *4800/2400 bits per second modem with automatic equalizer standardized for use on leased telephone-type circuits*, Rec. V.27 bis.
- [64] CCITT Recommendation *4800/2400 bits per second modem standardized for use in the general switched telephone network*, Rec. V.27 ter.
- [65] CCITT Recommendation *9600 bits per second modem standardized for use on point-to-point 4-wire leased telephone-type circuits*, Rec. V.29.
- [66] CCITT Recommendation *A family of 2-wire, duplex modems operating at data signalling rates of up to 9600 bit/s for use on the general switched telephone network and on leased telephone-type circuits*, Rec. V.32.
- [67] CCITT Recommendation *Usage of cause and location in the digital subscriber signalling system No. 1 and the signalling system No. 7 ISDN user part*, Rec. Q.850.
- [68] CCITT Recommendation *Operational provisions for the international public facsimile service between subscribers stations with group 3 facsimile machines (telex 3)*, Rec. F.182.
- [69] CCITT Recommendation *Operational provisions for the international public facsimile service between subscribers stations with group 4 facsimile machines (telex 4)*, Rec. F.184.
- [70] CCITT Recommendation *Service requirements unique to mixed mode (MM) used within the teletex service*, Rec. F.230.
- [71] CCITT Recommendation *Service requirements unique to the processable mode number one (PM1) used within the teletex service*, Rec. F.220.
- [72] CCITT Recommendation *Teletex service*, Rec. F.200.
- [73] CCITT Recommendation *Videotex service*, Rec. F.300.
- [74] CCITT Recommendation *Syntax-Based videotex end-to-end protocols for the circuit mode ISDN*, Rec. T.102.
- [75] CCITT Recommendation *International interworking for videotex services*, Rec. T.101.
- [76] CCITT Recommendation *Operational provisions for the international telex service*, Rec. F.60.
- [77] CCITT Recommendation *Data communication networks: Message handling systems (MHS)*, Recs. X.400-Series.
- [78] CCITT Recommendation *Open systems interconnection (OSI): Model and notation, service definition*, Recs. X.200-Series.
- [79] CCITT Recommendation *Videotelephony teleservice for ISDN*, Rec. F.721.
- [80] CCITT Recommendation *Audiographic services*, Recs. F.700-Series.
- [81] ISO/IEC 8878:1992 *Information technology – Telecommunications and information exchange between systems – Use of X.25 to provide the OSI connection-mode Network Service*.

Superseded by a more recent version

- [82] ISO/IEC TR9577:1990 *Information technology – Telecommunications and information exchange between systems – Protocol identification in the network layer.*
- [83] CCITT Recommendation *Stage 3 description for supplementary services using DSS1*, Recs. Q.950-Series.
- [84] CCITT Recommendation *Stage 3 description for call completion supplementary services using DSS1*, Rec. Q.953.
- [85] CCITT Recommendation *Stage 3 description for number identification supplementary services using DSS1*, Rec. Q.951.
- [86] CCITT Recommendation *Stage 3 description for call offering supplementary service using DSS1*, Rec. Q.952.