



INTERNATIONAL TELECOMMUNICATION UNION

ITU-T

TELECOMMUNICATION
STANDARDIZATION SECTOR
OF ITU

T.123

(11/94)

TERMINALS FOR TELEMATIC SERVICES

**PROTOCOL STACKS FOR AUDIOGRAPHIC
AND AUDIOVISUAL TELECONFERENCE
APPLICATIONS**

ITU-T Recommendation T.123

(Previously "CCITT Recommendation")

FOREWORD

The ITU-T (Telecommunication Standardization Sector) is a permanent organ of the International Telecommunication Union (ITU). The ITU-T is responsible for studying technical, operating and tariff questions and issuing Recommendations on them with a view to standardizing telecommunications on a worldwide basis.

The World Telecommunication Standardization Conference (WTSC), which meets every four years, establishes the topics for study by the ITU-T Study Groups which, in their turn, produce Recommendations on these topics.

The approval of Recommendations by the Members of the ITU-T is covered by the procedure laid down in WTSC Resolution No. 1 (Helsinki, March 1-12, 1993).

ITU-T Recommendation T.123 was prepared by ITU-T Study Group 8 (1993-1996) and was approved under the WTSC Resolution No. 1 procedure on the 11th of November 1994.

NOTE

In this Recommendation, the expression "Administration" is used for conciseness to indicate both a telecommunication administration and a recognized operating agency.

© ITU 1995

All rights reserved. No part of this publication may be reproduced or utilized in any form or by any means, electronic or mechanical, including photocopying and microfilm, without permission in writing from the ITU.

CONTENTS

	<i>Page</i>
1 Scope.....	1
1.1 Networks identified	1
1.2 Audio and video signals.....	1
1.3 Two profile modes.....	1
1.4 ISDN call set-up	1
2 Normative references	1
3 Definitions.....	3
4 Abbreviations	3
5 Multipoint configuration	4
6 Profile overview	4
7 Basic mode profiles.....	8
7.1 ISDN basic mode profile	8
7.2 CSDN basic mode profile	9
7.3 PSDN basic mode profile	10
7.4 PSTN basic mode profile.....	11
8 Extended mode profiles.....	12
8.1 ISDN extended mode profile	12
8.2 CSDN extended mode profile.....	13
8.3 PSDN extended mode profile	14
8.4 PSTN extended mode profile.....	15
9 Synchronization and convergence function	16
9.1 SCF overview	16
9.2 SCF procedures.....	17
9.3 SCF messages	18
9.4 Quality of Service parameters.....	22
10 Q.922 protocol parameters and options.....	22
11 Data link frame structure transparency for start-stop transmission.....	23
12 Physical sublayer formed by H.221 MLP channels	24
Annex A – Integration of multimedia signals framed according to Recommendation H.221	27
Appendix I – Audiographic conference call set-up in the ISDN.....	27
I.1 Introduction	27
I.2 Basic requirements.....	28
I.3 Connection phase.....	28
I.4 Phase A (ISDN D-channel protocol)	29
I.5 Phase B (H.242 protocol)	29
I.6 Phase C (T.120-Series protocol).....	29
Appendix II – Possible profiles for local area networks	33
Appendix III – A possible profile for broadband ISDN.....	34

SUMMARY

This Recommendation specifies network aspects of the T.120-Series of protocols for audiographic conference service. The networks currently identified are ISDN, CSDN, PSDN, and PSTN. Communication profiles are specified which provide reliable point-to-point connections between a terminal and a multipoint control unit, between pairs of terminals, or between pairs of MCUs. In the case of ISDN and CSDN, the lower layers support the multiplexing of audio and video signals in addition to data connections. In the case of PSDN and PSTN, it is currently assumed that separate calls will be established to carry any audio or video signals, in a manner that is left unspecified.

PROTOCOL STACKS FOR AUDIOGRAPHIC AND AUDIOVISUAL TELECONFERENCE APPLICATIONS

(Geneva, 1994)

1 Scope

This Recommendation, which defines common protocol stacks for terminals and MCUs, specifies network aspects of the AGC protocol suite, in the form of profiles for each network identified. Each profile specifies a set of protocols which may extend to layer 7 of the OSI reference model, depending upon the mode selected.

The rationale for this Recommendation is as follows: audiographic and video conferencing are intended to form part of the repertoire of ISDN services. Teleconferencing via ISDN involves the integration of multimedia (audio, video and data) in a connection which may be the aggregate of a number of physical channels. The provision of these services is not, however, limited to the ISDN, and a range of other network scenarios is identified. For instance, CSDN may provide a similar, though less flexible, service to that of the ISDN. In cases where the audio and video signals are provided separately, the data channel for control and enhancement of the teleconference may be provided via PSDN or PSTN.

1.1 Networks identified

Network specific profiles are defined for ISDN, CSDN, PSDN and PSTN, as required by CCITT Recommendation F.710. The extension of this Recommendation to include future broadband networks is envisaged and is a matter for further study.

1.2 Audio and video signals

The handling of audio and video signals in a teleconference is not part of this Recommendation, other than their multiplexed transport in the cases of ISDN and CSDN.

1.3 Two profile modes

Two profile modes are specified for each network:

- a) a basic mode profile, defined in clause 7, using a 4-layer stack;
- b) an extended mode profile, defined in clause 8, using a 7-layer stack.

The extended mode profiles of b) require further study.

1.4 ISDN call set-up

Examples of ISDN call set-up procedures for the audiographic teleconference are given in Appendix I. These procedures illustrate:

- a) the use of ISDN information elements;
- b) coordination of the D-channel and the B-channel;
- c) the phases of connection establishment;
- d) interworking with telephone services.

2 Normative references

The following Recommendations and other references contain provisions which, through reference in this text, constitute provisions of this Recommendation. At the time of publication, the editions indicated were valid. All Recommendations and other references are subject to revision: all users of this Recommendation are therefore

encouraged to investigate the possibility of applying the most recent edition of the Recommendations and other references listed below. A list of currently valid ITU-T Recommendations is regularly published.

- CCITT Recommendation F.701 (1988), *Teleconference service*.
- CCITT Recommendation F.710 (1991), *General principles for audiographic conference service*.
- CCITT Recommendation T.90 (1992), *Characteristics and protocols for terminals for telematic services in ISDN*.
- ITU-T Recommendation T.122 (1993), *Multipoint Communication Service for audiographics and audiovisual conferencing service definition*.
- ITU-T Recommendation T.125 (1994), *Multipoint Communication Service protocol specification*.
- ITU-T Recommendation H.221 (1993), *Frame structure for a 64 to 1920 kbit/s channel in audiovisual teleservices*.
- ITU-T Recommendation H.230 (1993), *Frame-synchronous control and indication signals for audiovisual systems*.
- ITU-T Recommendation H.231 (1993), *Multipoint control units for audiovisual systems using digital channels up to 2 Mbit/s*.
- ITU-T Recommendation H.242 (1993), *System for establishing communication between audiovisual terminals using digital channels up to 2 Mbit/s*.
- CCITT Recommendation X.227 (1992), *Association control protocol specification for Open Systems Interconnection for CCITT applications*.
- CCITT Recommendation X.226 (1988), *Presentation protocol specification for Open Systems Interconnection for CCITT applications*.
- CCITT Recommendation X.225 (1988), *Session protocol specification for Open Systems Interconnection for CCITT applications*.
- CCITT Recommendation X.224 (1988), *Transport protocol specification for Open Systems Interconnection for CCITT applications*.
- CCITT Recommendation X.217 (1992), *Association control service definition for Open Systems Interconnection for CCITT applications*.
- CCITT Recommendation X.214 (1988), *Transport service definition for Open Systems Interconnection for CCITT applications*.
- CCITT Recommendation X.213 (1992), *Network service definition for Open Systems Interconnection for CCITT applications*.
- CCITT Recommendation I.320 (1988), *ISDN protocol reference model*.
- ITU-T Recommendation Q.920 (1993), *ISDN user-network interface data link layer – General aspects*.
- ITU-T Recommendation Q.921 (1993), *ISDN user-network interface – Data link layer specification*.
- CCITT Recommendation Q.922 (1992), *ISDN data link layer specification for frame mode bearer services*.
- ITU-T Recommendation Q.931 (1993), *ISDN user-network interface layer 3 specification for basic call control*.
- ITU-T Recommendation Q.933 (1993), *Layer 3 signalling specification for frame mode bearer service*.
- ITU-T Recommendation I.430 (1993), *Basic user-network interface – Layer 1 specification*.
- ITU-T Recommendation I.431 (1993), *Primary user-network interface – Layer 1 specification*.

- CCITT Recommendation X.21 (1992), *Interface between data terminal equipment and data circuit-terminating equipment for synchronous operation on public data networks.*
- CCITT Recommendation X.21 bis (1988), *Use on public data networks of data terminal equipment (DTE) which is designed for interfacing to synchronous V-Series modems.*
- ITU-T Recommendation X.25 (1993), *Interface between data terminal equipment (DTE) and data circuit-terminating equipment (DCE) for terminals operating in the packet mode and connected to public data networks by dedicated circuit.*
- CCITT Recommendation V.7 (1988), *Definition of terms concerning data communication over the telephone network.*
- ITU-T Recommendation V.14 (1993), *Transmission of start-stop characters over synchronous bearer channels.*
- ISO/IEC 3309: 1991, *Information technology – Telecommunications and information exchange between systems – High-level data link control (HDLC) procedures – Frame structure.*

3 Definitions

This Recommendation uses the following terms defined in CCITT Recommendation F.701:

- audiographic conference service;
- multipoint control unit.

This Recommendation uses the following terms defined in CCITT Recommendation I.320:

- control plane;
- user plane.

This Recommendation uses the following term defined in ITU-T Recommendation Q.920:

- data link connection identifier.

This Recommendation uses the following term defined in CCITT Recommendation Q.922:

- synchronization and convergence function.

This Recommendation uses the following term defined in CCITT Recommendation V.7:

- start-stop transmission.

This Recommendation uses the following term defined in CCITT Recommendations. X.214 and X.213:

- Quality of Service.

4 Abbreviations

For the purpose of this Recommendation, the following abbreviations apply:

ACSE	Association control service element
AGC	Audiographic conference
CSDN	Circuit switched data network
DLCI	Data link connection identifier
FCS	Frame check sequence
ISDN	Integrated services digital network
MCS	Multipoint Communication Service
MCSAP	MCS service access point

MCU	Multipoint control unit
NSAP	Network service access point
OSI	Open Systems Interconnection
PSDN	Packet switched data network
PSTN	Public switched telephone network
QOS	Quality of Service
SCF	Synchronization and convergence function
TPDU	Transport protocol data unit
TSAP	Transport service access point

5 Multipoint configuration

A multipoint configuration is created from individual network connections between three or more terminals and MCUs. Figure 1 shows a typical configuration where terminals are connected in a multipoint star to an MCU. It also shows how MCUs may be interconnected to form a larger conference.

Figure 2 shows the framework of the AGC protocol suite. This Recommendation defines the network specific protocols in any direct connection between terminal and MCU, between two terminals, or between two MCUs.

6 Profile overview

The general structure of the network specific profiles is shown in Figures 3 and 4. Two profiles are defined for each network, a basic mode and an extended mode. Profiles for both modes are defined in detail in the following clauses.

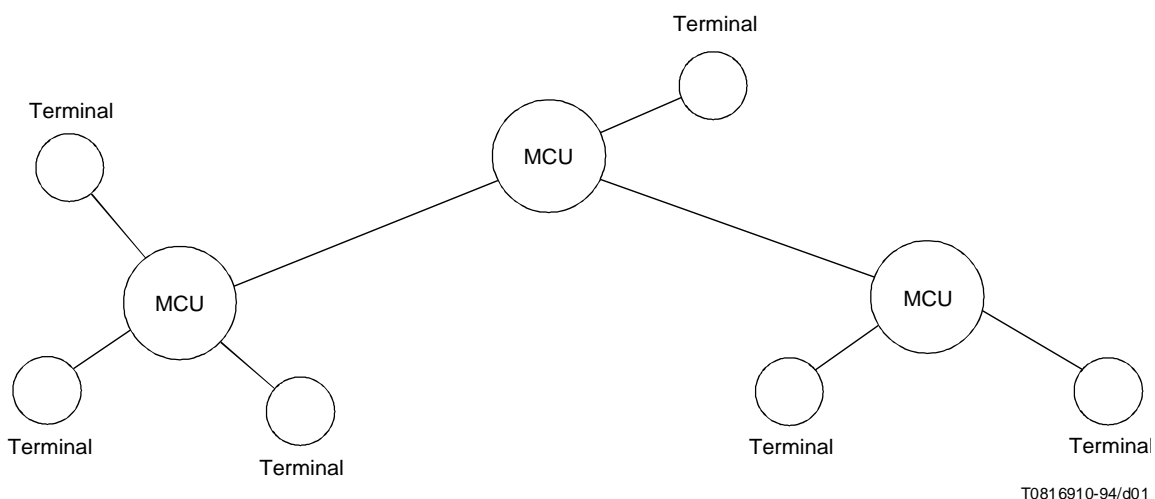

FIGURE 1/T.123
Typical multipoint configuration

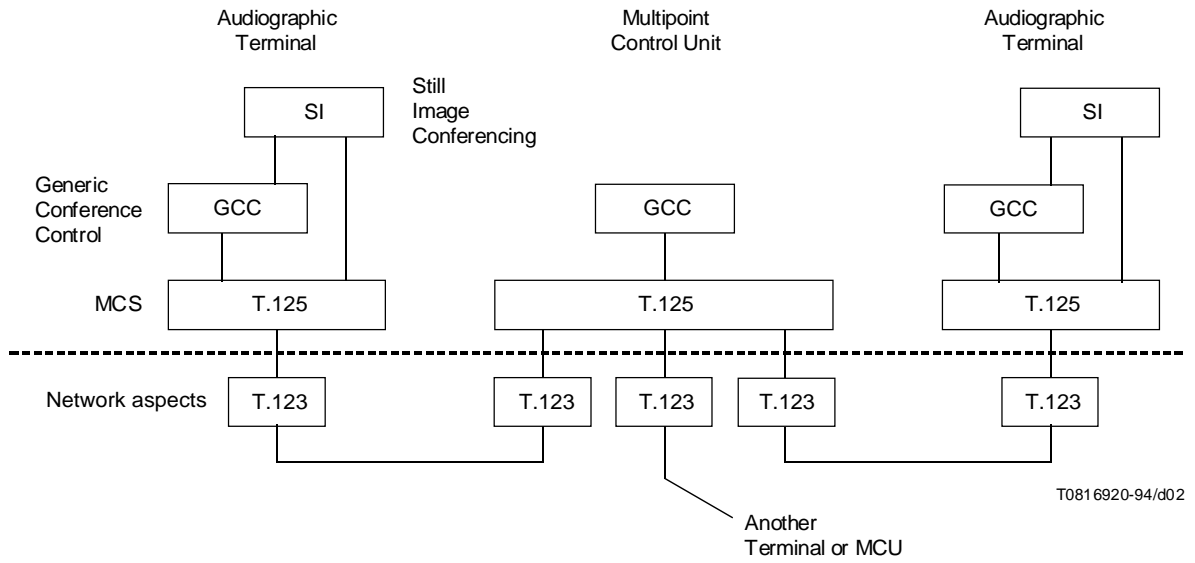

FIGURE 2/T.123
Framework of the AGC protocol suite

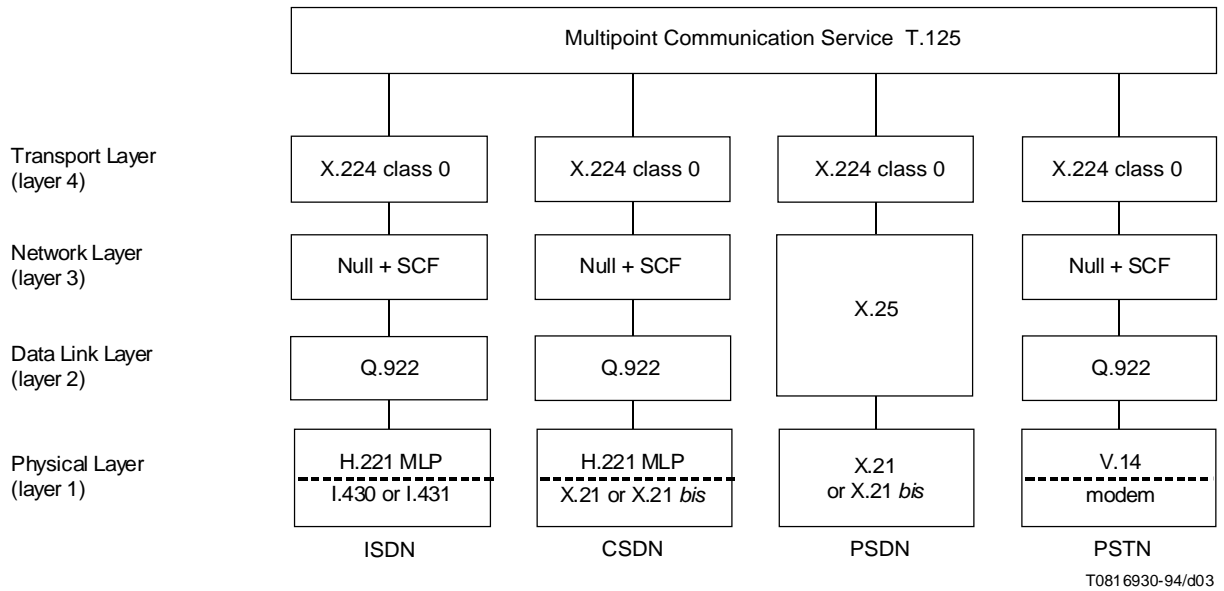

FIGURE 3/T.123
Basic mode profiles general structure

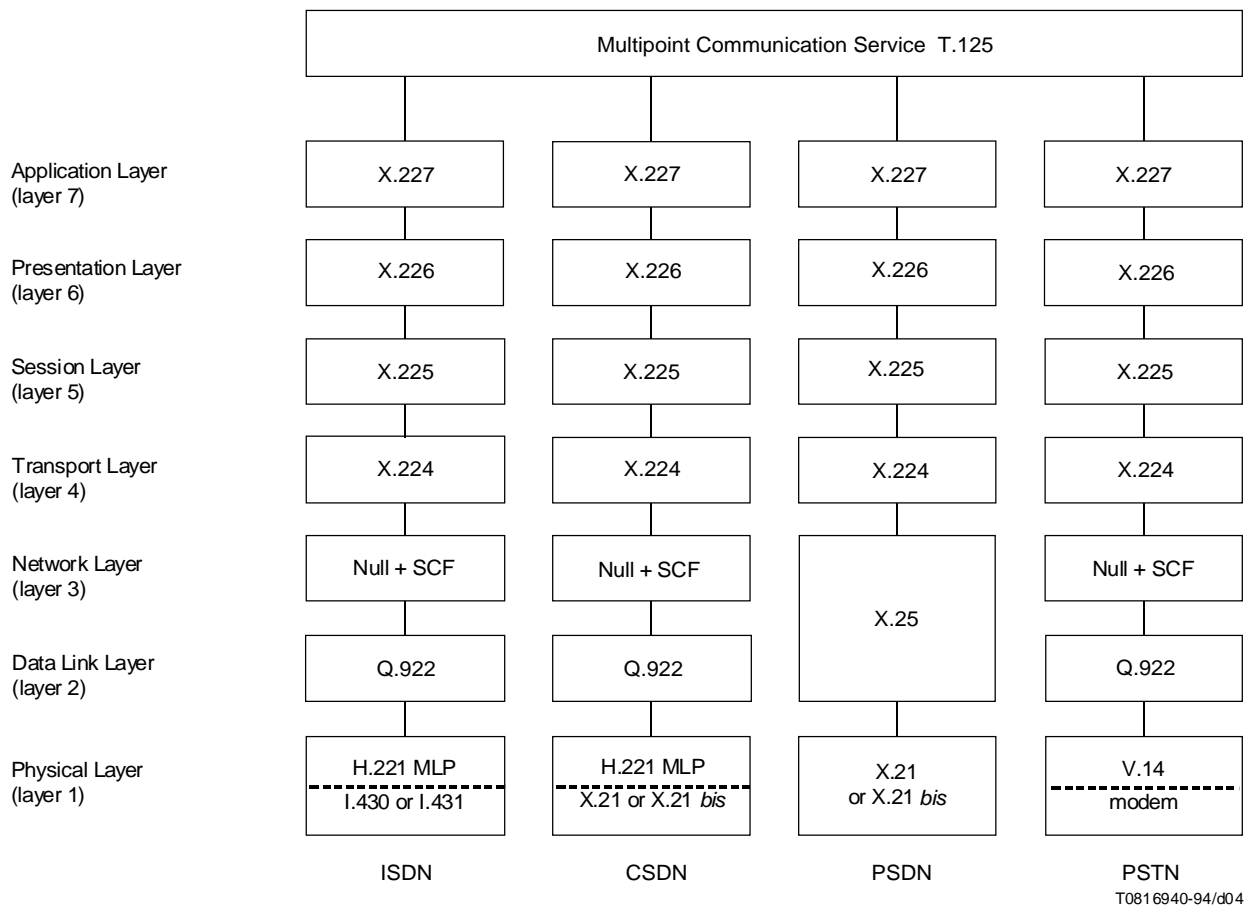

FIGURE 4/T.123

Extended mode profiles general structure

The use of Recommendation Q.922 over ISDN does not imply the use of a frame relay bearer service. Recommendation Q.922 is used to enhance the quality of service provided by the physical layer of an ISDN, CSDN, or PSTN. This Recommendation exploits the error recovery mechanisms of Q.922 multiframe acknowledged mode for operation over a point-to-point connection provided by an ISDN, CSDN, or PSTN.

Figure 5 shows the location of an MCS provider in the OSI reference model. An MCS provider exchanges MCS protocol data units with remote MCS providers. For this purpose, it uses transport-layer services in basic mode and association control and presentation-layer services in extended mode, respectively. An MCS provider communicates with MCS users through an MCSAP by means of the MCS primitives defined in ITU-T Recommendation T.122.

To simplify the address information that must be supplied when establishing an MCS connection, it is recommended that terminals and MCUs be administered for the basic mode profiles so that null NSAP and TSAP selectors will resolve to an MCS provider at the destination system.

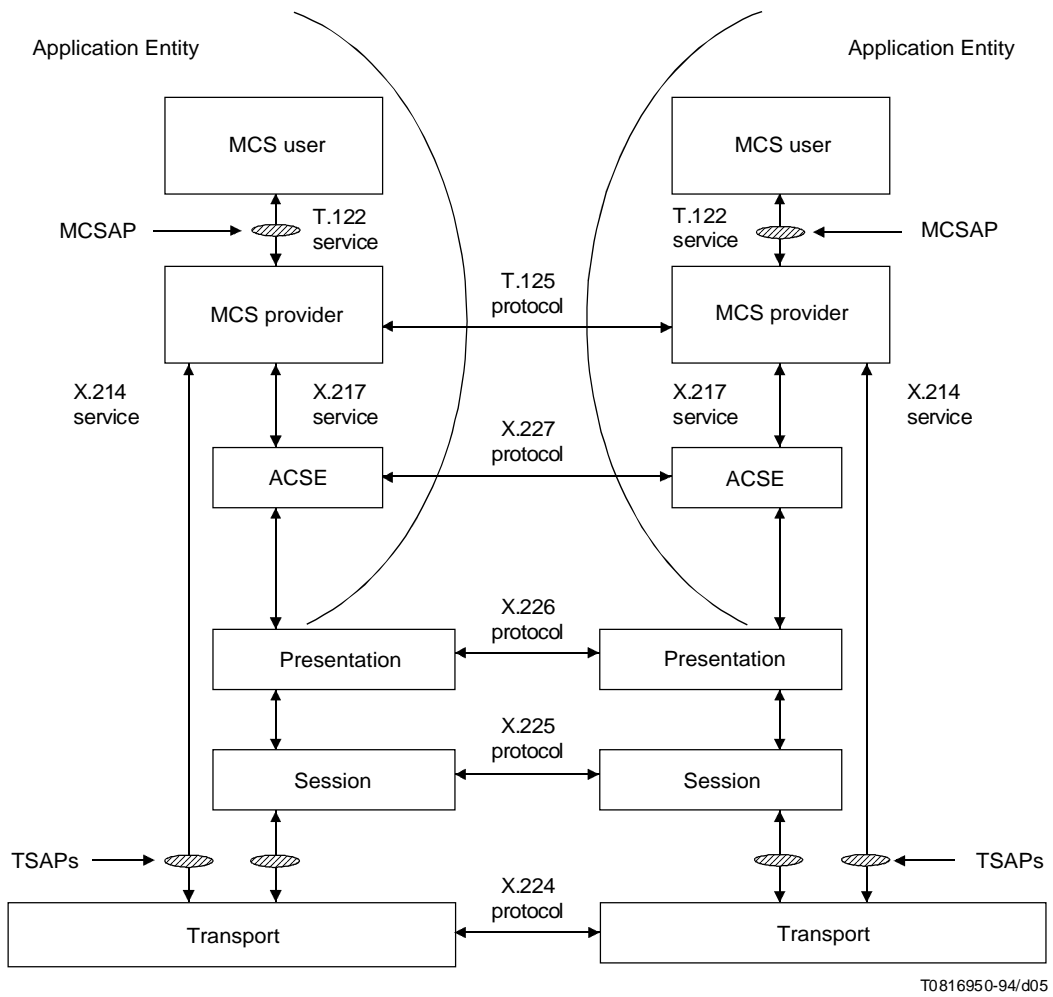

FIGURE 5/T.123
Location of an MCS provider in the OSI reference model

7 Basic mode profiles

7.1 ISDN basic mode profile

Figure 6 defines the ISDN basic mode profile.

NOTE – This Recommendation does not specify call set-up in the ISDN (although possible scenarios are illustrated in Appendix I). The SCF shown here operates only in the MLP channel, after ISDN call set-up and H.242 mode switching have occurred.

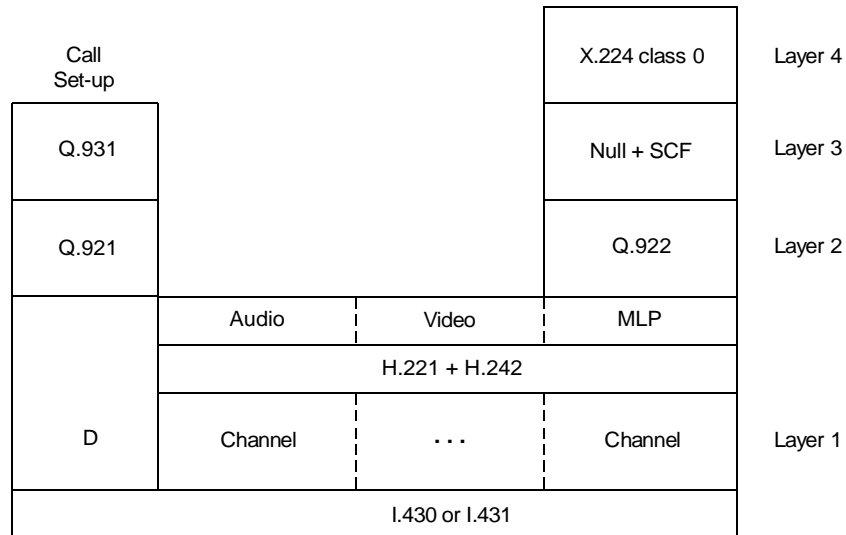

T0816960-94/d06

- Layer 4 – X.224.
- Class 0 preferred, no alternative class.
 - Maximum TPDU size shall not exceed Layer 2 parameter N201.
- Layer 3 – *User plane* – Null (no extra protocol during data transfer).
- *Control plane* – SCF as specified in clause 9.
- Layer 2 – Q.922.
- Protocol parameters and options as specified in clause 10.
- Layer 1 *Sublayer formed by H.221 MLP channels:*
- As specified in clause 12.
- Sublayer formed by ISDN:*
- 1-6 B-channels, or 1-5 H0-channels, or 1 H1-channel.
 - Unrestricted digital information, optionally with tones and announcements.
 - B-channels may be rate-adapted to 56 kbit/s for restricted networks.
 - D-channel is used for network signalling only, not for user data.

FIGURE 6/T.123
ISDN basic mode profile

7.2 CSDN basic mode profile

Figure 7 defines the CSDN basic mode profile. Layers above H.221 are identical to the ISDN profile.

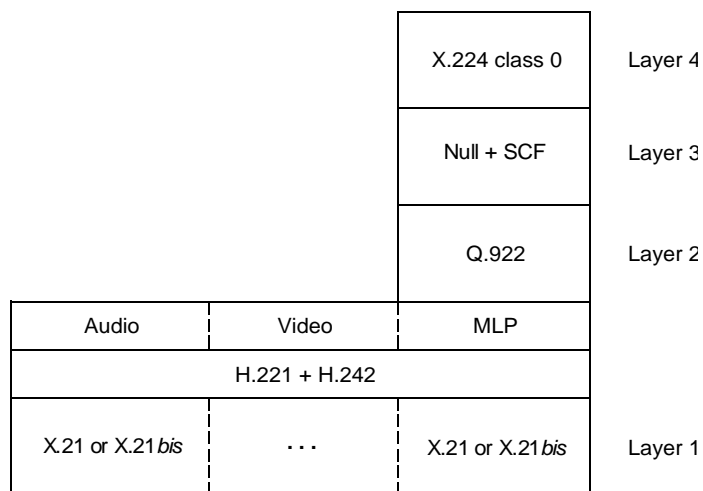

T0816970-94/d07

Layer 4 – As specified in 7.1.

Layer 3 – As specified in 7.1.

Layer 2 – As specified in 7.1.

Layer 1 *Sublayer layer formed by H.221 MLP channel:*

– As specified in clause 12.

Sublayer formed by CSDN:

– X.21 or X.21 bis for each circuit switched connection.

– Bit rates shall be a uniform multiple of 64 kbit/s or 56 kbit/s.

FIGURE 7/T.123
CSDN basic mode profile

7.3 PSDN basic mode profile

Figure 8 defines the PSDN basic mode profile.

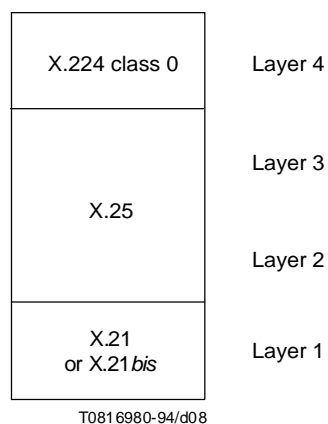

- Layer 4 – X.224.
 - Class 0 preferred, no alternative class.
- Layer 3 – X.25 virtual call service.
- Layer 2 – X.25 LAPB single link procedure.
- Layer 1 – X.21 or X.21 *bis*.

FIGURE 8/T.123
PSDN basic mode profile

7.4 PSTN basic mode profile

Figure 9 defines the PSTN basic mode profile. Layers above Q.922 are identical to the ISDN profile.

NOTE – The multiplexing of audio and video signals over the PSTN is a subject for further study.

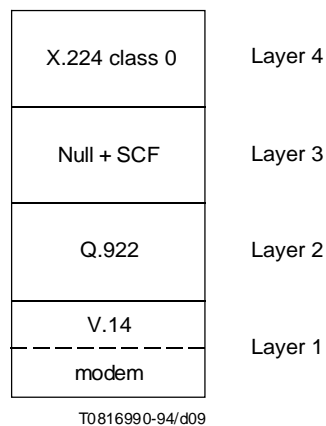

Layer 4 – As specified in 7.1.

Layer 3 – As specified in 7.1.

Layer 2 – Q.922.

- Protocol parameters and options as specified in clause 10.
- Modified frame transparency based on ISO 3309, as specified in clause 11.

Layer 1 – Start-stop transmission by data terminal equipment.

- One start bit, one stop bit, eight data bits, no parity.
- Any compatible V-Series modems may be employed.

FIGURE 9/T.123

PSTN basic mode profile

8 Extended mode profiles

This clause presents a preliminary view of the extended mode profiles. Details require further study.

8.1 ISDN extended mode profile

Figure 10 defines the ISDN extended mode profile.

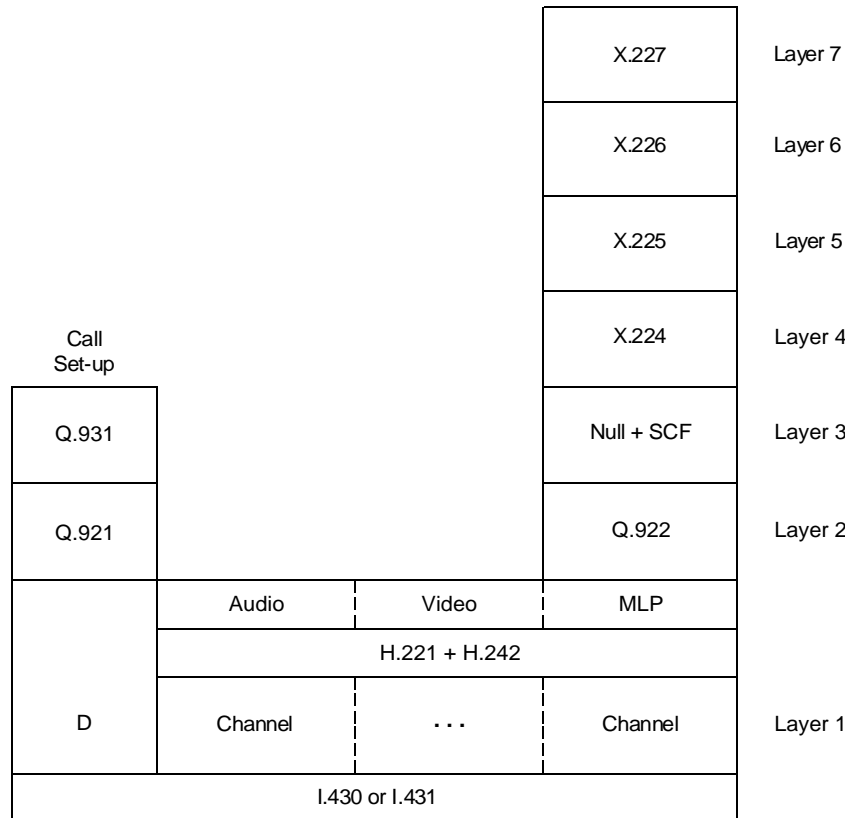

T0817000-94/d10

- Layer 7 – X.227.
- Layer 6 – X.226.
- Layer 5 – X.225.
- Layer 4 – X.224.
 - Class 0 or class 2 – For further study.
 - Maximum TPDU size shall not exceed Layer 2 parameter N201.
- Layer 3 – *User plane* – Null (no extra protocol during data transfer).
 - *Control plane* – SCF as specified in clause 9.
- Layer 2 – Q.922.
 - Protocol parameters and options as specified in clause 10.
- Layer 1 – As specified in 7.1.

FIGURE 10/T.123
ISDN extended mode profile

8.2 CSDN extended mode profile

Figure 11 defines the CSDN extended mode profile. Layers above H.221 are identical to the ISDN profile.

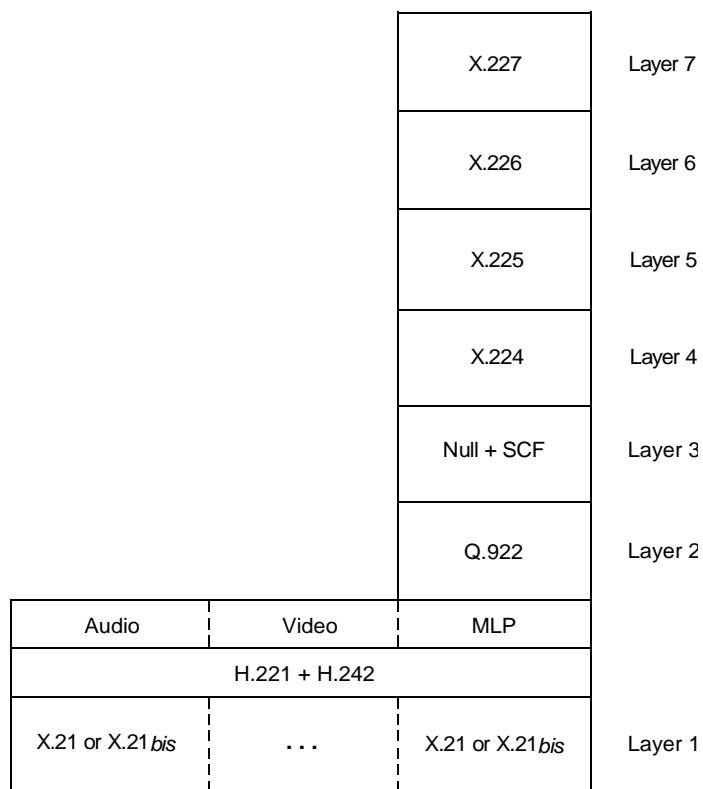

T0817010-94/d11

- Layer 7 – X.227.
- Layer 6 – X.226.
- Layer 5 – X.225.
- Layer 4 – As specified in 8.1.
- Layer 3 – As specified in 8.1.
- Layer 2 – As specified in 8.1.
- Layer 1 – As specified in 7.2.

FIGURE 11/T.123
CSDN extended mode profile

8.3 PSDN extended mode profile

Figure 12 defines the PSDN extended mode profile.

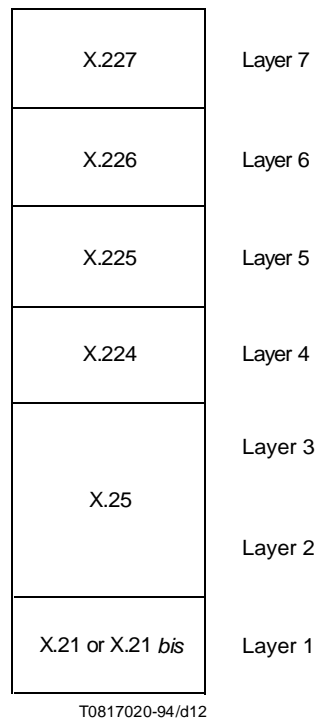

Layer 7 – X.227.

Layer 6 – X.226.

Layer 5 – X.225.

Layer 4 – X.224.

– Class 0 or class 2 – For further study.

Layer 3 – As specified in 7.3.

Layer 2 – As specified in 7.3.

Layer 1 – As specified in 7.3.

FIGURE 12/T.123
PSDN extended mode profile

8.4 PSTN extended mode profile

Figure 13 defines the PSTN extended mode profile. Layers above Q.922 are identical to the ISDN profile.

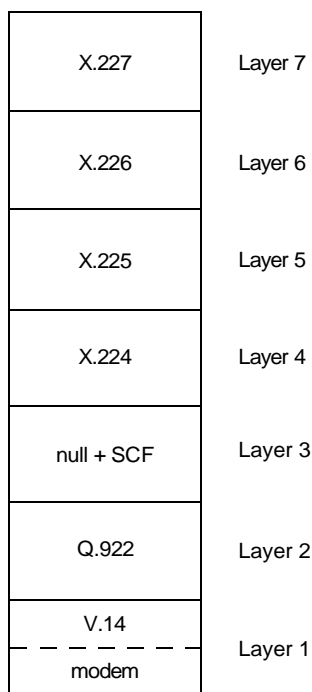

T0817030-94/d13

Layer 7 – X.227.

Layer 6 – X.226.

Layer 5 – X.225.

Layer 4 – As specified in 8.1.

Layer 3 – As specified in 8.1.

Layer 2 – Q.922.

– Protocol parameters and options as specified in clause 10.

– Modified frame transparency based on ISO 3309. as specified in clause 11.

Layer 1 – As specified in 7.4.

FIGURE 13/T.123
PSTN extended mode profile

9 Synchronization and convergence function

9.1 SCF overview

The SCF resides in the network layer of each communication profile whose data link layer is specified to be Q.922. It coordinates network connection establishment and release between the control plane and the user plane as described in clause 4/Q.922. The purpose of the SCF is to provide network services to the transport layer. Figure 14 is the architectural model of the SCF.

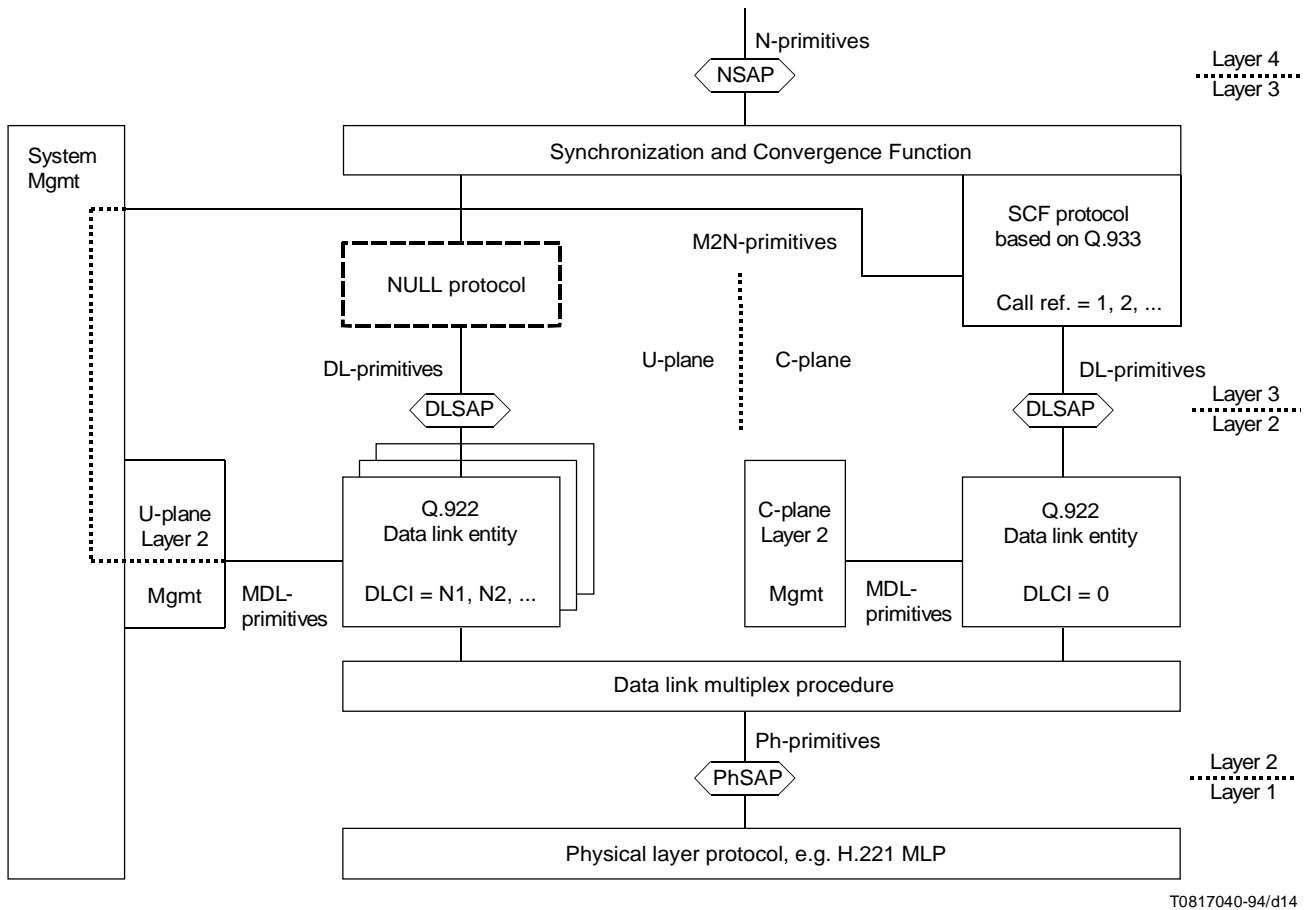

FIGURE 14/T.123
Architectural model of the SCF

Network services required by the X.224 transport protocol are listed in Table 1. This table is derived from Table 2/X.224 by excluding optional features and N-RESET (because N-RESET is never requested, according to Table A.3/X.224, and any indication of it can be escalated to N-DISCONNECT).

The SCF implements the N-CONNECT and N-DISCONNECT primitives. During data transfer it is inactive, and N-DATA maps directly to DL-DATA with no extra protocol. This requires that the transport layer limit the size of its TPDU's to one Q.922 I frame.

TABLE 1/T.123

Network services required by Recommendation X.224

Primitives	Parameters
N-CONNECT request N-CONNECT indication	Called address Calling address QOS parameter set
N-CONNECT response N-CONNECT confirm	Responding address QOS parameter set
N-DATA request N-DATA indication	NS user data
N-DISCONNECT request N-DISCONNECT indication	

Recommendation Q.922 supports multiple data link connections distinguished by DLCI. Acting through layer 2 management, the SCF controls DLCI assignments. It communicates with a peer SCF by sending and receiving Q.933 messages over DLCI 0, which is reserved for in-channel signalling. DLCI 0 serves the control plane, supporting SCF control. Other DLCIs serve the user plane, supporting data transfer.

SCF procedures are based on those specified in Recommendation Q.933, in which are defined a case A covering circuit switched access to a remote frame handler and a case B covering integrated access to a local frame handler. The SCF use of Q.933 messages may be considered a new case C covering circuit switched access directly to another network user. This new case C does not use DLCIs to distinguish connections to different destinations. It uses DLCIs to distinguish multiple connections between the same two endpoints. Each such connection may have a different quality of service.

The sequence of actions to obtain a physical circuit between two users can vary with the communication profile and other circumstances. A circuit may be established without the aid of SCF, prior to the first N-CONNECT request and indication. When these primitives are finally invoked, called and calling addresses may be omitted or ignored. Alternatively, N-CONNECT request may initiate events, and network addresses may be required for circuit routing.

9.2 SCF procedures

The SCF shall act as a network user is required to act for Q.933 case A of frame relaying. It shall behave as though connected semi-permanently to a remote frame handler, even though the bit rate allotted to the physical circuit may not be exactly an ISDN information transfer rate.

The sole exception is 5.6/Q.933 concerning DLCI collisions. To maintain a symmetric relationship between two network users, the SCF shall give neither direction preference as incoming. Instead, it shall resolve collisions by forcing new DLCI selections on both sides, as specified in detail below.

The SCF shall obey the additional requirements stated in the remainder of this subclause.

As soon as a duplex physical circuit is activated, the SCF shall assign and establish DLCI 0 to serve the control plane. DLCI 0 shall carry Q.933 messages in Q.922 I frames. If DLCI 0 is ever re-established, which indicates a protocol error, the SCF shall cause it to be released. If DLCI 0 is ever released, the SCF shall remove all other DLCIs assigned to the physical circuit and shall indicate that their data links are disconnected. The SCF may then attempt to establish DLCI 0 again and reinitialize Q.933 signalling.

As a positive response to SETUP, the SCF shall transmit CONNECT, and this shall be answered by CONNECT ACKNOWLEDGE. In this situation there is no advantage in transmitting ALERTING, CALL PROCEEDING, or PROGRESS. If received, these messages may be ignored.

The negative response to SETUP shall be RELEASE COMPLETE. This is also the simplest means of clearing an established call. In this situation there is no advantage in transmitting DISCONNECT, RELEASE, STATUS, or STATUS ENQUIRY. If received, these message may stimulate the transmission of RELEASE COMPLETE. Although an unexpected RELEASE COMPLETE is considered a message sequence error, it achieves the intended effect of forcing the receiver to clear a call.

Figure 15 shows the messages exchanged and primitives invoked during a successful N-CONNECT. The figure assumes that DLCI 0 is already established, as the result of exchanging SABME and UA when the physical circuit was activated.

The SCF shall employ one-octet call reference values (ranging from 1 to 127 on each side) and two-octet DLCI values (comprising 10 bits). DLCIs shall be selected randomly within the range allotted by Recommendation Q.922 for support of user information, namely, from 16 to 991 inclusive.

An SCF processing N-CONNECT request shall propose a preferred DLCI value in SETUP. An SCF receiving SETUP shall consider the DLCI value it contains. It is an error if the DLCI value is already assigned. If the receiving SCF has proposed the same DLCI value in an unanswered SETUP, it shall respond RELEASE COMPLETE with cause number 44 *requested circuit/channel not available*. Otherwise, it shall accept the received DLCI value. Its response to SETUP shall then depend on a consideration of other parameters and the will of the network user. If the response is positive, the same DLCI value shall be returned in CONNECT; if negative, a cause number other than 44 shall be returned in RELEASE COMPLETE. An SCF receiving a response of RELEASE COMPLETE with cause number 44 shall retry its failed SETUP with a new randomly selected DLCI value. If the number of retries seems excessive, the SCF may choose to reseed its random number generator. An SCF receiving a response of RELEASE COMPLETE with a cause number other than 44 shall indicate through N-DISCONNECT that the N-CONNECT request failed.

Figure 16 shows the messages exchanged and primitives invoked following a user-requested N-DISCONNECT. Note that DL-RELEASE request and the transmission of DISC are not required, because MDL-REMOVE on each side properly resets the state of the affected DLCI.

An unrecovered error in data transfer over a DLCI is indicated by DL-ESTABLISH or by DL-RELEASE, depending on the success of resetting the data link. Either of these shall cause N-DISCONNECT to begin with an indication instead of a request, followed by the remaining actions of Figure 16. The exception is if DLCI 0 is affected; this has the more severe consequences specified earlier.

9.3 SCF messages

Information elements appear in a fixed order, as shown in Tables 2 through 5. Those of type M are either mandatory in Recommendation Q.933 or required as part of the specification of this SCF. Those of type O are optional. Information elements that are not listed here should not be transmitted and may be ignored if received.

NOTE – If NSAP and TSAP selectors for an MCS provider are administered to be null, as recommended in clause 6, there is no advantage in carrying subaddress information elements as part of SETUP and CONNECT. Their possible use to support protocols other than T.125 sharing the same physical circuit is for further study.

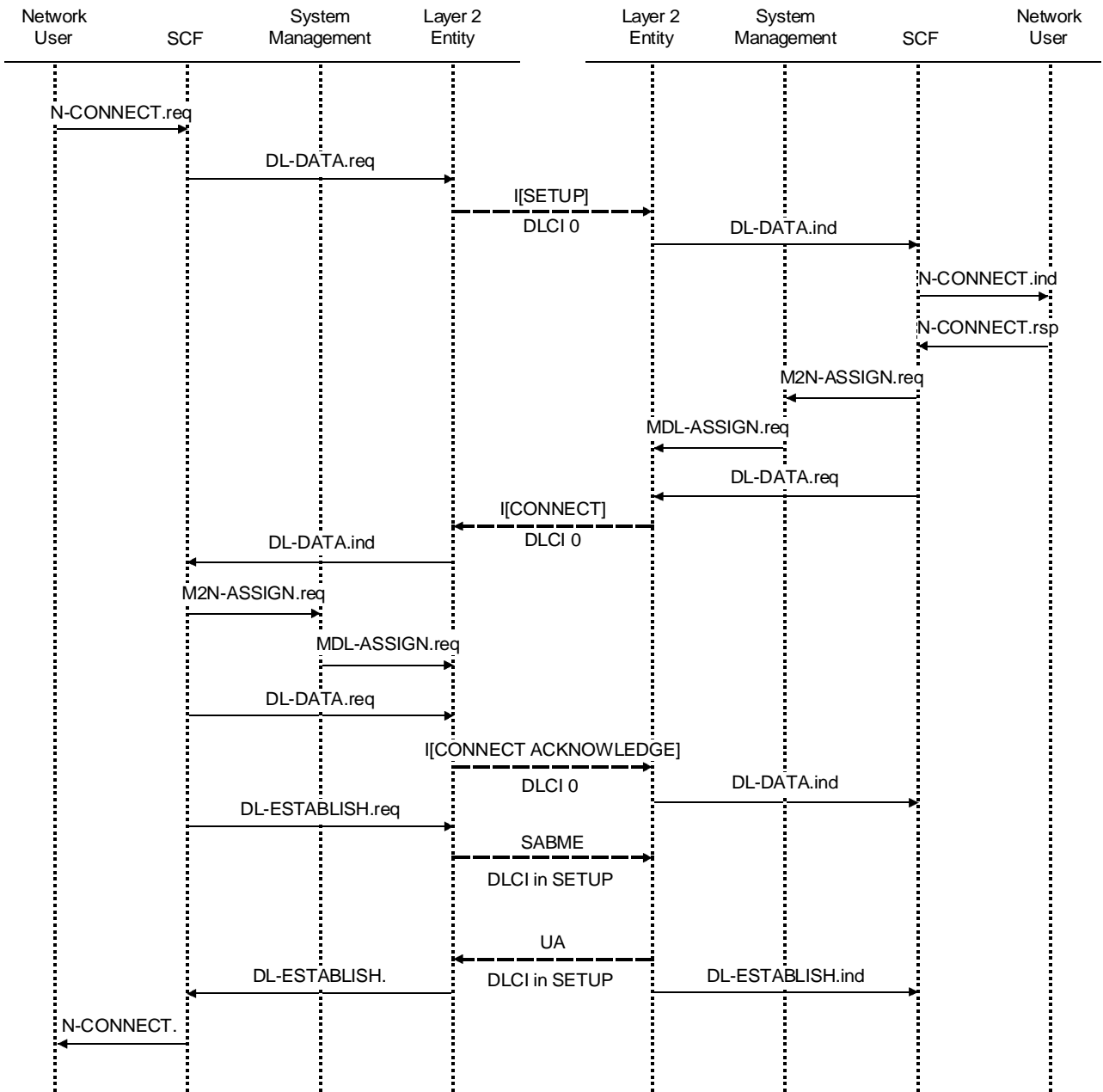

T081 7050-94/d15

FIGURE 15/T.123
Sequence of actions for N-CONNECT

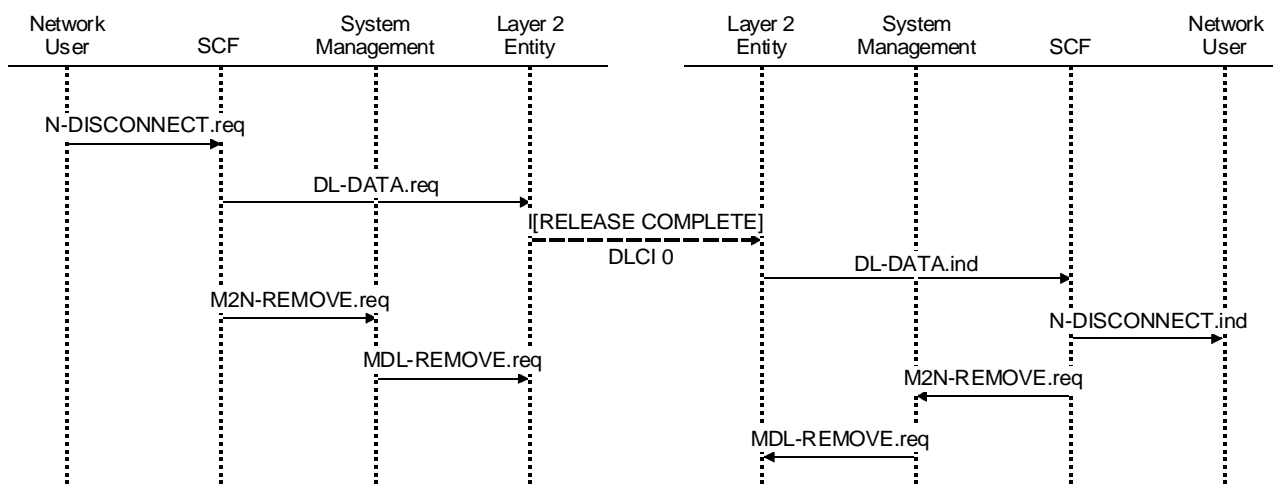

T081 7060-94/d1 6

FIGURE 16/T.123
Sequence of actions for N-DISCONNECT

TABLE 2/T.123

SETUP message content

Information element	Type	Notes
Protocol discriminator	M	
Call reference	M	
Message type	M	
Bearer capability	M	Q.922
DLCI	M	Preferred
End-to-end transit delay	O	Cumulative, requested, maximum
Link layer core parameters	O	N201, throughput(s), minimum(s)
Link layer protocol parameters	O	k, T.200
X.213 priority	O	Data priority, lowest acceptable
Calling party subaddress	O	NSAP address
Called party subaddress	O	NSAP address

TABLE 3/T.123

CONNECT message content

Information element	Type	Notes
Protocol discriminator	M	
Call reference	M	
Message type	M	
DLCI	M	Exclusive
End-to-end transit delay	O	Cumulative
Link layer core parameters	O	N201, throughput(s)
Link layer protocol parameters	O	k, T.200
Connected subaddress	O	NSAP address
X.213 priority	O	Data priority

TABLE 4/T.123

CONNECT ACKNOWLEDGE message content

Information element	Type
Protocol discriminator	M
Call reference	M
Message type	M

TABLE 5/T.123

RELEASE COMPLETE message content

Information element	Type
Protocol discriminator	M
Call reference	M
Message type	M
Cause	M

9.4 Quality of Service parameters

Important characteristics of data transfer performance are throughput, transit delay, and priority. These are part of the QOS parameter set of N-CONNECT. QOS parameters are separate from but may influence the choice of protocol parameters. Parameters of both kinds may be conveyed by the SCF using optional information elements in SETUP and CONNECT.

Parameter negotiations shall obey the rules of 5.1.3.3/Q.933 and 5.2.3.3/Q.933.

System parameters of Q.922 that may be negotiated are: k, N201, and T.200. Their value shall be the same for both directions of transfer. If these parameters are not explicitly signalled, they shall take the default values of clause 10 below.

If QOS parameters are not explicitly signalled, the corresponding qualities are indeterminate and may take any values that are convenient for the service providers.

The QOS and protocol parameters in CONNECT, supplemented by any defaults, shall be final values for the assigned DLCI. The SCF shall pass these to the underlying layer 2 entity by M2N-ASSIGN, which emerges from the management plane as MDL-ASSIGN. This accords with 4.1.1.5/Q.922 and 4.1.1.10/Q.922, which note that additional optional parameters may be included in these primitives.

The QOS and protocol parameters of DLCI 0 are not explicitly signalled. The QOS shall implicitly equal or exceed that of any other DLCI. The protocol parameters k, N201, and T.200 for DLCI 0 shall take the default values.

A layer 2 entity may or may not implement data priority as a QOS parameter. If it does, the relative priority of DLCIs should determine the order of servicing user data requests queued for transmission, assuming that their respective protocol states are equally ready. DLCIs of the same priority should be treated impartially.

The SCF shall express data priorities using the value encoding of the information element *X.213 priority* (which agrees with the encoding of the X.25 packet layer). The lowest priority shall be 0 and the highest shall be at most 14. Requested priorities shall be negotiated downward into the range of values, beginning with 0, that the underlying layer 2 entity can implement distinctly.

10 Q.922 protocol parameters and options

The address field format shall be two octets (10 bit DLCIs).

Three bits of the address field are reserved for use with frame relaying service: forward explicit congestion notification (FECN), backward explicit congestion notification (BECN), and discard eligibility (DE). These bits shall be set to 0 by the transmitter and shall be ignored by the receiver.

Information transfer shall be in I frames using the procedures of multiple frame acknowledged operation.

Frame types UI and XID shall not be transmitted.

System parameters are associated with each individual data link connection. Their values should be set taking into account characteristics of the underlying physical circuit. Default values are specified in Table 6.

Values of k, N201, and T.200 can be negotiated by the SCF specified in clause 9. The values of N200 and T.203 need not be communicated from transmitter to receiver and may be set locally on each side.

The default value of k is the maximum value cited in 5.9.4/Q.922 (for a link speed of 1536 - 1920 Mbit/s). This is also the value cited in Appendix VI/T.90, independent of the link speed, for optimum throughput with a packet size of 256 octets.

TABLE 6/T.123

Data link default system parameter values

System parameter	Default value	Parameter description
k	40	Maximum number of outstanding I frames
N200	10	Maximum number of transmissions
N201	260	Maximum number of octets in an information field
T.200	1.5 seconds	Retransmission timer
T.203	30 seconds	Idle timer

A value of k that is too large is better than a value that is too small. A Q.922 receiver need not accept a full window of I frames if buffers are scarce; it can set the *own receiver busy* condition at some intermediate point. Moreover, a Q.922 transmitter can voluntarily limit itself to a smaller number of outstanding I frames; it is not obliged to fill the window to maximum capacity. On the other hand, if k is set small and the window fills too quickly, a transmitter is required to cease. Throughput and response may suffer.

Appendix I/Q.933 suggests a procedure to negotiate the value of k using a formula that involves the data frame size in octets.

Implementors should consider the possibility of limiting frame size dynamically to a smaller value than system parameter N201 allows. This may require coordination with the transport layer that is forming TPDU's. It may be prudent to restrict the worst-case serial transmission time of lower priority data, so that newly queued data of higher priority can be serviced promptly. A maximum latency of 60 milliseconds has been suggested.

The alternative option of aborting a low priority transmission already in progress may also be considered.

11 Data link frame structure transparency for start-stop transmission

Since start-stop transmission is organized as a sequence of octets, it is convenient to use an octet-stuffing scheme for data link frame structure transparency. This is a recognized alternative to the bit-stuffing scheme (insert a 0 bit after all sequences of five contiguous 1 bits) that is suitable for synchronous transmission. It makes the implementation of Recommendation Q.922 for the PSTN profile easier and more efficient, especially when using the serial port of a typical personal computer.

For the PSTN case, 2.6/Q.922, which defines frame structure transparency by reference to ITU-T Recommendation Q.921, shall not be implemented. In its place shall be implemented the following procedures taken from ISO/IEC 3309, subclause 4.5.2.

The control escape octet is a transparency identifier that identifies an octet occurring within a frame to which the following transparency procedure is applied. The encoding of the escape octet is given in Figure 17.

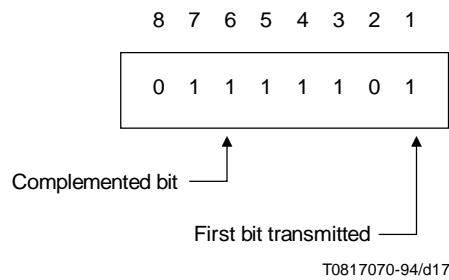

FIGURE 17/T.123
Control escape octet for start-stop transparency

The transmitter shall examine the frame content between the opening and closing flag sequences including the address, control, and FCS fields and, following completion of the FCS calculation, shall:

- a) upon the occurrence of the flag or a control escape octet, complement the 6th bit of the octet; and
- b) insert a control escape octet immediately preceding the octet resulting from the above prior to transmission.

The receiver shall examine the frame content between the two flag octets and shall, upon receipt of a control escape octet and prior to FCS calculation:

- a) discard the control escape octet; and
- b) restore the immediately following octet by complementing its 6th bit.

Other octet values may optionally be included in the transparency procedure by the transmitter.

12 Physical sublayer formed by H.221 MLP channels

Use of the H.221 MLP and H-MLP channels shall conform to the specifications of ITU-T Recommendations H.221, H.230, and H.242 for the integration of multimedia signals.

- To determine a compatible mode of operation, H.242 capability exchange sequence A applies.
- All systems capable of MLP shall declare at least the common capability MLP-6.4k.
- Other MLP and H-MLP bit rates defined by Recommendation H.221 may also be declared.
- To establish or change mode, H.242 mode switching sequence B applies.
- Upon receipt of an H.221 command opening MLP or H-MLP, a system shall act to ensure that at least one of these is open in the opposite direction, so that full duplex communication may occur.
- The bit rates of MLP and H-MLP need not be the same in both directions of transmission, unless symmetry is explicitly commanded.
- H.230 command MCS (multipoint command symmetrical data transmission) applies to MLP and H-MLP, requiring that the outgoing bit rates be set equal to the incoming.

As suggested in 9.2/H.242, if both MLP and H-MLP are in force, their bit rates shall be combined to form a single serial stream. Bit positions shall be numbered horizontally across the synchronized H.221 framing of initial and additional channels, as illustrated in Tables 7 through 9.

H.221 commands to set the rate of MLP or H-MLP shall not affect bit stream integrity unless their effect is to open or close the combined serial stream. Otherwise, the input or output of bits shall simply continue in the next sub-multiframe at a modified rate. The operation of higher layer protocols should not be disrupted.

TABLE 7/T.123

**Bit positions for MLP-6.4 k,
restricted, encryption active**

Initial channel							
1	2	3	4	5	6	7	8
						FAS	1
							1
							1
						BAS	1
							1
						ECS	1
							1
						M1	1
						M2	1
						•	1
						•	1
						M55	1
						M56	1
FAS Frame alignment signal BAS Bit-rate allocation signal ECS Encryption control signal							

TABLE 8/T.123

Bit positions for MLP-6.4 k plus H-MLP-62.4 k

Initial channel								Additional channel							
1	2	3	4	5	6	7	8	1	2	3	4	5	6	7	8
							FAS	M1	M2	M3	M4	M5	M6	M7	
								M8	•	•	•	•	•	M14	FAS
								•	•	•	•	•	•	•	
							BAS	•	•	•	•	•	•	•	BAS
								M106	•	•	•	•	•	M112	
							M113	M114	•	•	•	•	•	M120	M121
							•	•	•	•	•	•	•	•	•
							•	•	•	•	•	•	•	•	•
							M680	•	•	•	•	•	•	•	M688

TABLE 9/T.123

Bit positions for H-MLP-128 k in an H0 channel

Time-slot 1	Time-slot 2	Time-slot 3	Time-slot 4	Time-slot 5	Time-slot 6
	M1 • • M8	M9 • • M16			
	M17 • • •	• • • M32			
	• • • •	• • • •			
	• • • •	• • • •			
	M1265 • • •	• • • M1280			

Annex A

Integration of multimedia signals framed according to Recommendation H.221

(This annex forms an integral part of this Recommendation)

Figure A.1 illustrates how H.221 aggregates the throughput of one or more digital channels and then partitions the total transfer rate into bit rate allocations for the individual media.

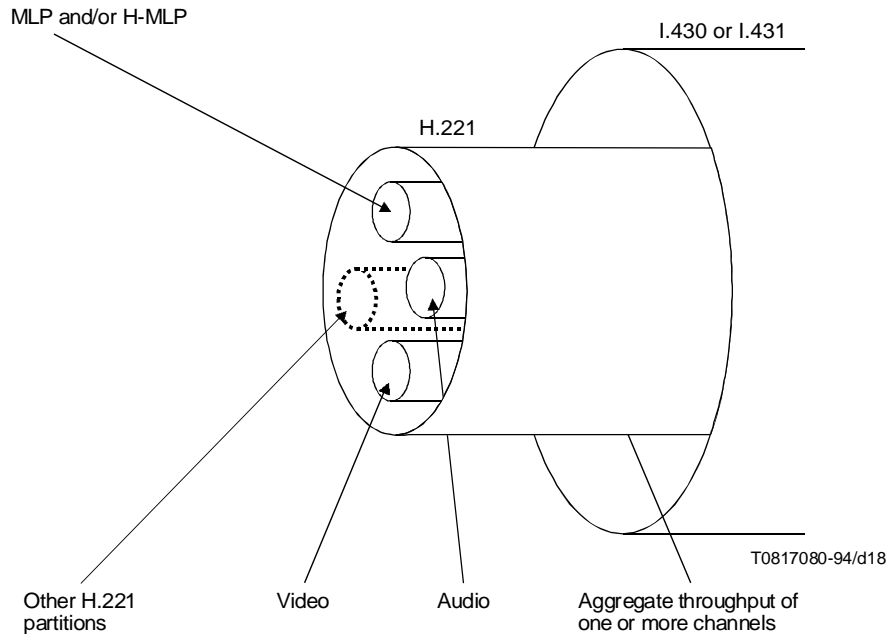

FIGURE A.1/T.123

Integration of multimedia signals framed according to Recommendation H.221

Appendix I

Audiographic conference call set-up in the ISDN

(This appendix does not form an integral part of this Recommendation)

I.1 Introduction

Audiographic Conference (AGC) terminals, currently under standardization in ITU-T, are basically intended to operate within the ISDN. However, various terminals of different types such as telephone, facsimile Group 4, videophones, and teleconference systems are also connected to the ISDN.

The following scenarios are derived from Recommendation Q.931, which provides more information and describes other possibilities. Attention should be paid to the coding of information elements for BC, LLC, and HLC, because they are important for interworking.

Table I.1 suggests values that may be used in a SETUP message. The called side terminal should also accept other values of the information elements for BC, LLC, and HLC. Alternative settings include unrestricted digital information with tones and announcements (UDI-TA), rate adaptation to 56 kbit/s for restricted networks, double BC/HLC, and absence of LLC. When HLC is used, call acceptance should be configured by the user to allow either telephony 7 kHz, videotelephony, or telephony 3.1 kHz.

TABLE I.1/T.123

Parameter settings originated in SETUP message

Information element	BC	LLC	HLC
Information transfer capability	Unrestricted digital information	Unrestricted digital information	
Transfer mode	Circuit	Circuit	
Information transfer rate	64 kbit/s	64 kbit/s	
User information layer 1 protocol		H.221	
High layer characteristics identification			AC ^{a)}
^{a)} AC Audiographic teleconference VC (videoconferencing), VP (videophone) and AV (audiovisual) are acceptable in the case of the called side.			

I.2 Basic requirements

The following conditions are basically required:

- 1) An AGC terminal has the ISDN I/F function inside it and directly connects to the ISDN at a S(T) point.
- 2) An AGC terminal desires to intercommunicate with the following terminals:
 - a) AGC terminal.
 - b) Videophone, Teleconference with H.221 frame structure supported.

Items a) and b) mentioned above will be called together AV (audiovisual) terminals in the following.

Intercommunication between AGC terminals and telephones are the fundamental demand. But each side uses different ISDN services (e.g. AGC: unrestricted digital information, telephone: speech), therefore this type of intercommunication would be difficult, without using special sequences, as shown in Figures I.2 and I.3.

- 3) This description is on the point-to-point connection only. The outline of the sequence is shown in Figure I.1.

I.3 Connection phase

The connection procedure can be divided into the following three phases:

- 1) Phase A (ISDN D-channel protocol). By using the D-channel signalling protocol (Q.931), an AGC terminal makes the call control so as to establish an ISDN B-channel, for communicating with an AV terminal.

- 2) Phase B (H.242 protocol). An AGC terminal based on H.221 establishes frame alignment and decides communication mode based on the H.242 sequence (AGC mode/speech mode), and establishes the MLP path.
- 3) Phase C (T.120-Series protocol). In the case that both terminals have AGC functionality and decide to communicate by AGC mode, the T.120 AGC protocol is started and the final communication function in detail is decided, leading to the start of actual communication.

I.4 Phase A (ISDN D-channel protocol)

In making call control based on Recommendation Q.931 (D-channel signalling protocol), the parameters specified in Table I.1 are to be set in the SETUP message on the originating side. Here in this appendix, however, the table shows only about information elements of:

- 1) Bearer capability (BC);
- 2) Low layer capability (LLC);
- 3) High layer capability (HLC);

all of which are needed to recognize the other terminals communication capability.

An AGC terminal on the calling side should set the above parameters in the SETUP message for sending, whilst on the called side, it should check the parameters so as to judge the possibility of communication. Finding it possible to communicate, it may accept the call and connect to a B-channel. Then an AGC terminal starts to intercommunicate with an audiovisual terminal which may be another AGC terminal, or a another type of audiovisual terminal such as videophone.

I.5 Phase B (H.242 protocol)

After connecting to the B-channel, the following procedures should be carried out based on Recommendation H.242:

- 1) Frame alignment conforming to Recommendation H.221 is the mode. Then, by using BAS, the capability exchange sequence is executed in 7-bit PCM mode (mode 0F).
- 2) After each side recognizes the other's capability, they decide their own communication mode including common mode. That is, when both are sure of having MLP capability, the MLP path is established and the AGC protocol is started, leading to phase C.
- 3) In the case where one side has no MLP capability, their communication is limited to audio and possibly video (for example, if one side is an AGC and the other side is a videophone).

I.6 Phase C (T.120-Series protocol)

- 1) To establish a Data Link connection on the MLP path.
- 2) To establish layer 3 to 4 (or, if extended mode, layer 3 to 7).
- 3) After channels are established conforming to Recommendation T.125 the negotiations, in order to recognize each other's function regarding AGC and information necessary for the conference, are exchanged by applications like Generic Conference Control and Still Image Conferencing.

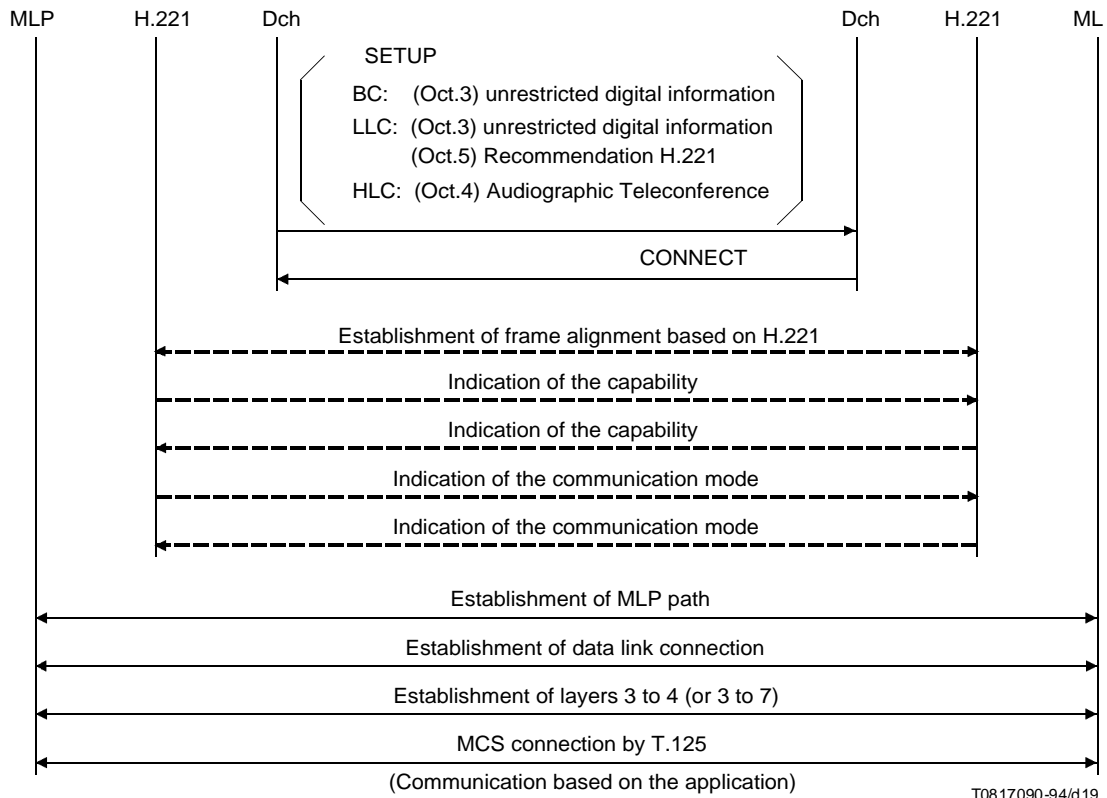
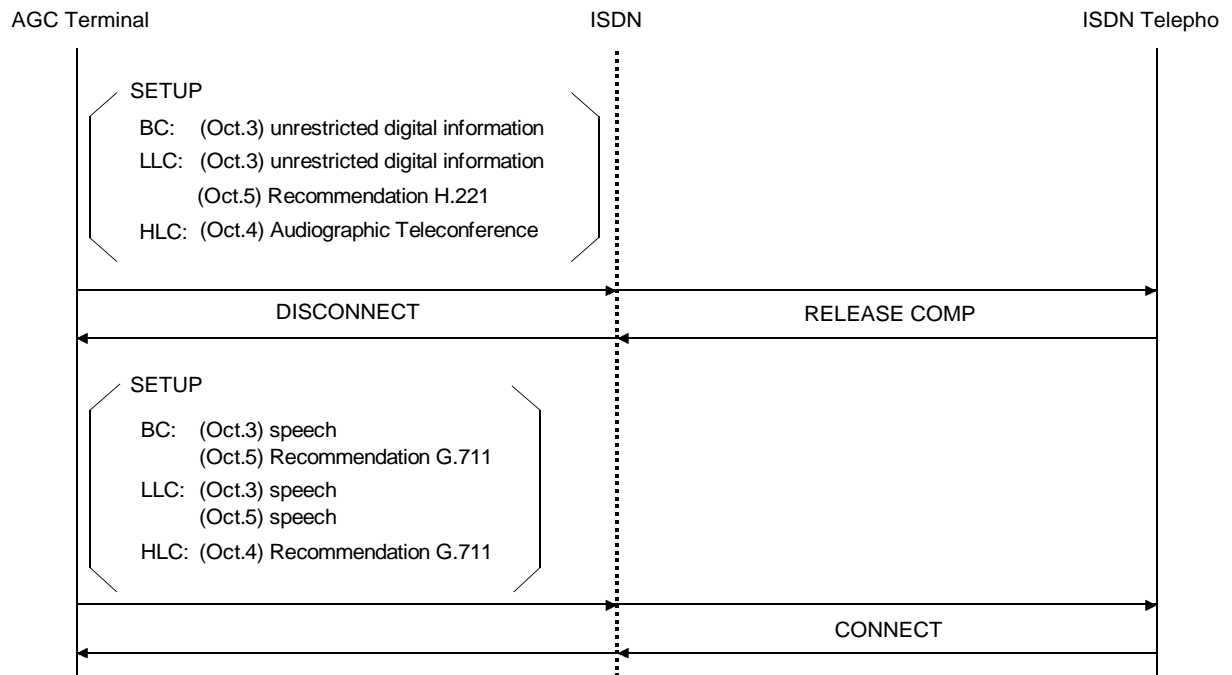
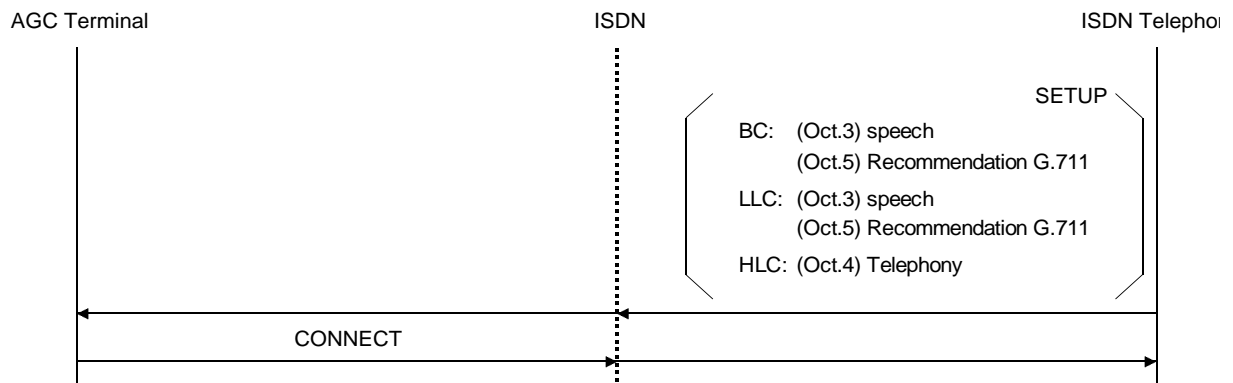

FIGURE I.1/T.123
Communication establishment sequence for AGC terminals



(Communication by means of speech service)

1) Call from AGC Terminal to ISDN Telephone



(Communication by means of speech service)

T0817100-94/d20

2) Call from ISDN Telephone to AGC Terminal

FIGURE I.2/T.123

Intercommunication sequences for AGC terminal and ISDN telephone

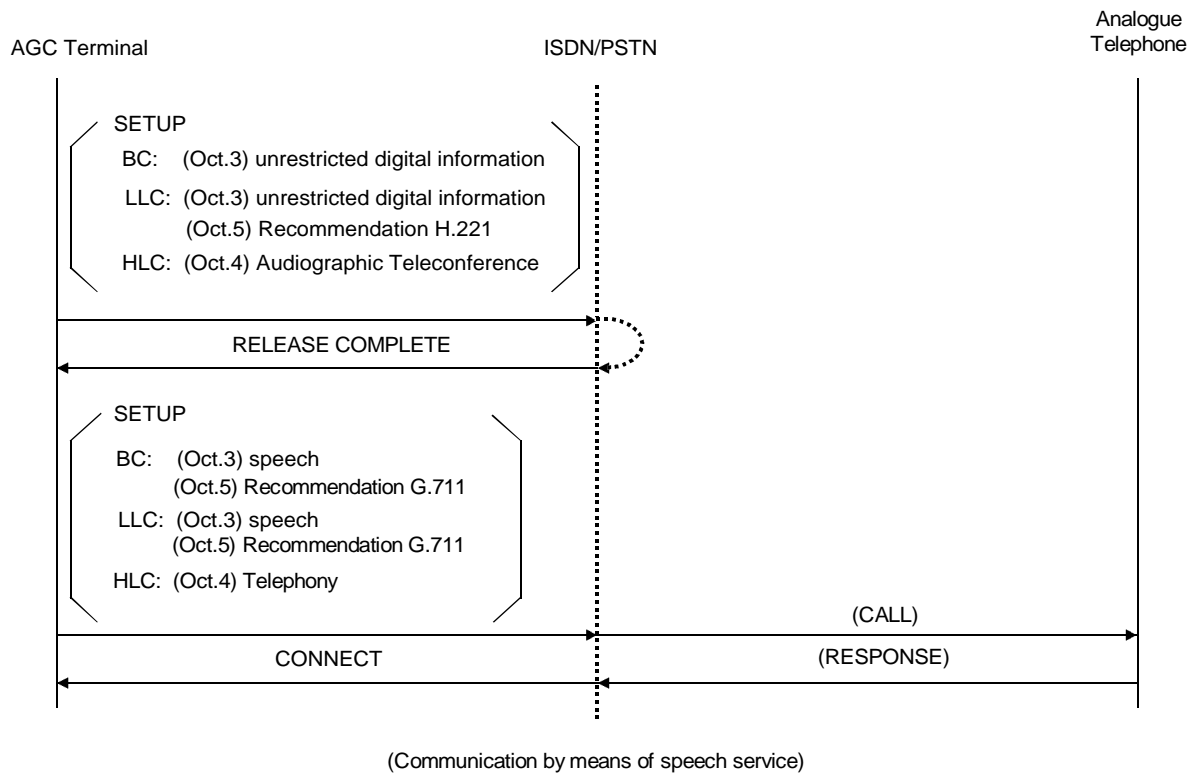

1) Call from AGC Terminal to Analogue Telephone

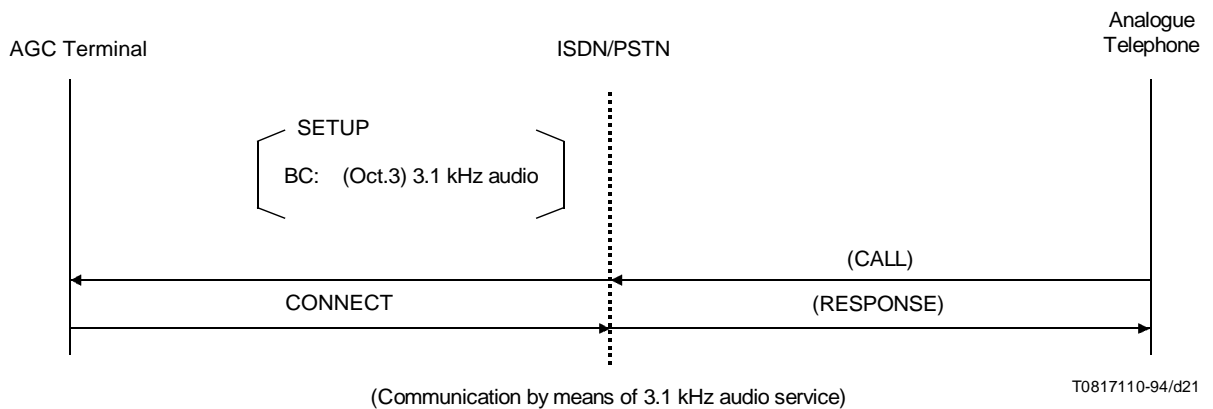

T0817110-94/d21

2) Call from Analogue Telephone to AGC Terminal

FIGURE I.3/T.123
Intercommunication sequences for AGC terminal and analogue telephone

Appendix II

Possible profiles for local area networks

(This appendix does not form an integral part of this Recommendation)

The definition of local area network profiles for the audiographic conference service is outside the scope of this Recommendation. Figure II.1 lists some possible profiles, in outline only.

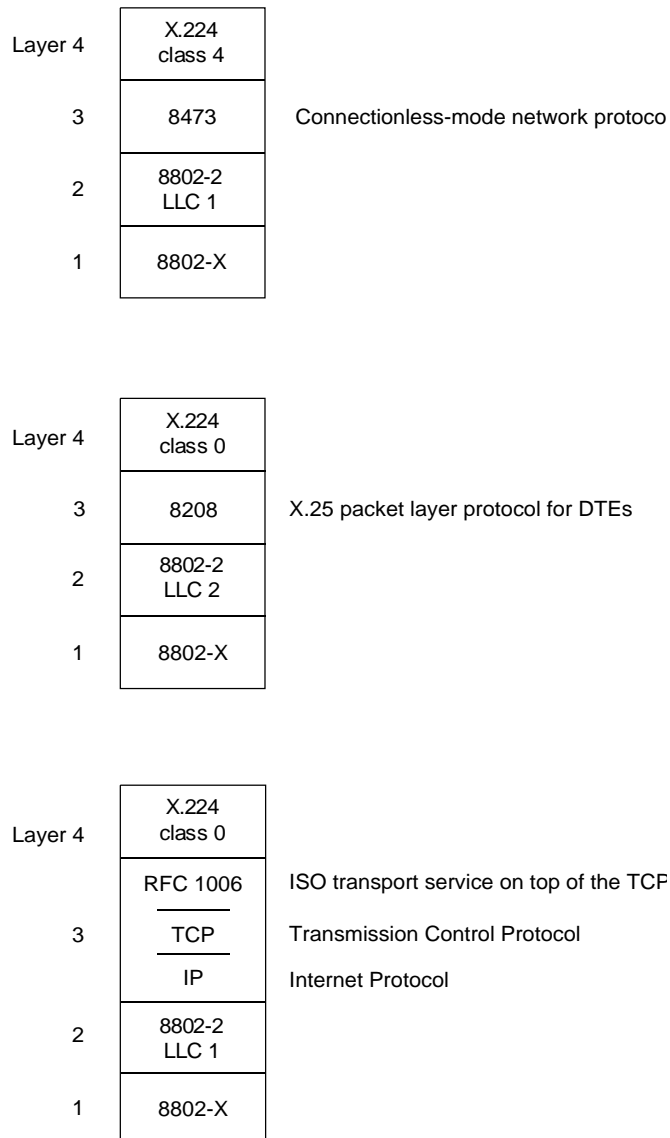

T0817120-94/d22

FIGURE II.1/T.123

Possible profiles for local area networks

Appendix III

A possible profile for broadband ISDN

(This appendix does not form an integral part of this Recommendation)

The definition of B-ISDN profiles for the audiographic conference service is a matter of current study. Figure III.1 shows a candidate protocol stack, in outline only.

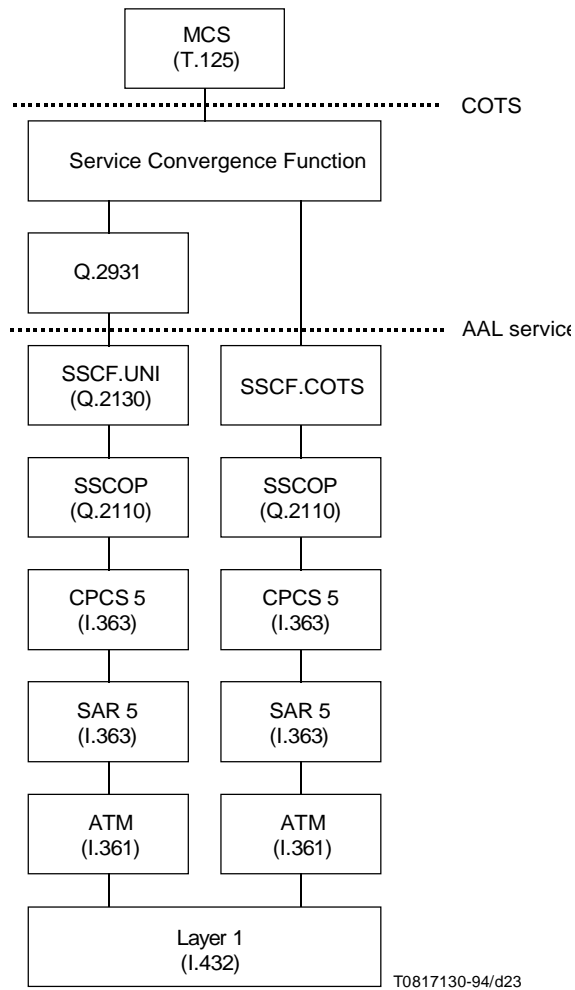

FIGURE III.1/T.123

A possible profile for Broadband ISDN

