

**Superseded by a more recent version**



INTERNATIONAL TELECOMMUNICATION UNION

**ITU-T**

TELECOMMUNICATION  
STANDARDIZATION SECTOR  
OF ITU

**T.123**

(10/96)

SERIES T: TERMINALS FOR TELEMATIC SERVICES

---

**Network specific data protocol stacks  
for multimedia conferencing**

ITU-T Recommendation T.123  
Superseded by a more recent version

(Previously CCITT Recommendation)

---

# **Superseded by a more recent version**

ITU-T T-SERIES RECOMMENDATIONS  
**TERMINALS FOR TELEMATIC SERVICES**

*For further details, please refer to ITU-T List of Recommendations.*

# Superseded by a more recent version

## FOREWORD

The ITU-T (Telecommunication Standardization Sector) is a permanent organ of the International Telecommunication Union (ITU). The ITU-T is responsible for studying technical, operating and tariff questions and issuing Recommendations on them with a view to standardizing telecommunications on a worldwide basis.

The World Telecommunication Standardization Conference (WTSC), which meets every four years, establishes the topics for study by the ITU-T Study Groups which, in their turn, produce Recommendations on these topics.

The approval of Recommendations by the Members of the ITU-T is covered by the procedure laid down in WTSC Resolution No. 1 (Helsinki, March 1-12, 1993).

ITU-T Recommendation T.123 was revised by ITU-T Study Group 8 (1993-1996) and was approved by the WTSC (Geneva, 9-18 October 1996).

---

## NOTE

In this Recommendation, the expression "Administration" is used for conciseness to indicate both a telecommunication administration and a recognized operating agency.

© ITU 1997

All rights reserved. No part of this publication may be reproduced or utilized in any form or by any means, electronic or mechanical, including photocopying and microfilm, without permission in writing from the ITU.

# Superseded by a more recent version

## CONTENTS

	<i>Page</i>
1 Scope .....	1
1.1 Networks identified.....	1
1.2 Audio and video signals.....	1
1.3 ISDN call set-up.....	1
2 References .....	1
3 Definitions .....	4
4 Abbreviations .....	5
5 Multipoint configuration.....	5
6 Profile overview .....	6
7 Basic profiles .....	8
7.1 ISDN basic profile .....	8
7.2 CSDN basic profile .....	9
7.3 PSDN basic profile.....	10
7.4 PSTN basic profile .....	10
7.5 B-ISDN basic profile .....	11
7.6 LAN basic profile.....	12
8 Packet header to delimit data units in an octet stream.....	13
9 Synchronization and convergence function.....	14
9.1 SCF overview.....	14
9.2 SCF procedures .....	16
9.3 SCF messages.....	18
9.4 Quality of service parameters.....	20
10 Q.922 protocol parameters and options .....	20
11 Data link frame structure transparency for start-stop transmission .....	21
12 Physical sublayer formed by H.221 MLP channels.....	22
13 Alternative profiles .....	26
13.1 Alternative: ISDN based on Recommendation Q.922 .....	26
13.2 Alternative: ISDN based on T.90.....	27
13.3 Alternative: ISDN based on Recommendation V.120 .....	28
13.4 Alternative: PSTN based on Recommendation H.324.....	29
13.5 Alternative: B-ISDN based on Recommendation H.222 .....	29
13.6 Alternative: LAN based on data unit transfer .....	30
Annex A – Integration of multimedia signals framed according to Recommendation H.221 .....	31
Appendix I – Multimedia conference call set-up in the ISDN.....	32
I.1 Introduction.....	32
I.2 Basic requirements .....	33
I.3 Connection phase .....	33
I.4 Phase A (ISDN D-channel protocol).....	34
I.5 Phase B (H.242 protocol).....	34
I.6 Phase C (T.120-Series protocol) .....	34

# **Superseded by a more recent version**

## **SUMMARY**

This Recommendation specifies network specific aspects of the T.120-Series of data protocols for multimedia conferencing. The networks currently identified are ISDN, CSDN, PSDN, PSTN, B-ISDN, and LAN. Communication profiles are specified which provide reliable point-to-point connections between a terminal and a multipoint control unit, between pairs of terminals, or between pairs of MCUs. In some cases, a lower protocol layer allows the multiplexing of audio and video signals in addition to data connections. In other cases, separate calls, over the same or a different network, may be established to carry audio or video signals.



# Superseded by a more recent version

Recommendation T.123

## NETWORK SPECIFIC DATA PROTOCOL STACKS FOR MULTIMEDIA CONFERENCING

(revised in 1996)

### 1 Scope

This Recommendation, which defines protocol stacks for terminals and MCUs, specifies network specific aspects of the T.120 protocol suite, in the form of profiles for each network identified. Each profile specifies a set of protocols that extend to layer 4 of the OSI reference model.

The rationale for this Recommendation is as follows: audiographic and video conferencing are intended to form part of the repertoire of ISDN services. Teleconferencing via ISDN involves the integration of multiple media (audio, video and data) in a connection which may be the aggregate of a number of physical channels. The provision of these services is not, however, limited to the ISDN, and a range of other network scenarios is identified. For instance, CSDN may provide a similar, though less flexible, service to that of the ISDN, and PSTN may provide a service that, though limited in performance, is more readily available. Teleconferencing may also be extended over PSDN and B-ISDN. LANs may provide conferencing locally within an enterprise or a means of access to wide area networks.

#### 1.1 Networks identified

Network specific profiles are defined for ISDN, CSDN, PSDN and PSTN, as required by Recommendation F.710. The scope of the present Recommendation includes B-ISDN and LAN too.

#### 1.2 Audio and video signals

The handling of audio and video signals in a multimedia conference is not part of this Recommendation, other than the possibility of their multiplexed transport over the same connection in some cases.

#### 1.3 ISDN call set-up

Examples of ISDN call set-up procedures for the audiographic teleconference are given in Appendix I. These procedures illustrate:

- a) the use of ISDN information elements;
- b) coordination of the D-channel and the B-channel;
- c) the phases of connection establishment;
- d) interworking with telephone services.

### 2 References

The following ITU-T Recommendations and other references contain provisions which, through reference in this text, constitute provisions of this Recommendation. At the time of publication, the editions indicated were valid. All Recommendations and other references are subject to revision: all users of this Recommendation are therefore encouraged to investigate the possibility of applying the most recent edition of the Recommendations and other references listed below. A list of the currently valid ITU-T Recommendations is regularly published.

- CCITT Recommendation F.701 (1988), *Teleconference service*.
- CCITT Recommendation F.710 (1991), *General principles for audiographic conference service*.
- ITU-T Recommendation H.221 (1995), *Frame structure for a 64 to 1920 kbit/s channel in audiovisual teleservices*.

## Superseded by a more recent version

- ITU-T Recommendation H.222.0 (1996), *Information technology – Generic coding of moving pictures and associated audio information: Systems.*
- ITU-T Recommendation H.222.1 (1996), *Multimedia multiplex and synchronization for audiovisual communication in ATM environments.*
- ITU-T Recommendation H.223 (1996), *Multiplexing protocol for low bit rate multimedia communication.*
- ITU-T Recommendation H.230 (1995), *Frame-synchronous control and indication signals for audiovisual systems.*
- ITU-T Recommendation H.231 (1996), *Multipoint control units for audiovisual systems using digital channels up to 1920 kbit/s.*
- ITU-T Recommendation H.233 (1995), *Confidentiality system for audiovisual services.*
- ITU-T Recommendation H.242 (1996), *System for establishing communication between audiovisual terminals using digital channels up to 2 Mbit/s.*
- ITU-T Recommendation H.243 (1996), *Procedures for establishing communication between three or more audiovisual terminals using digital channels up to 2 Mbit/s.*
- ITU-T Recommendation H.310 (1996), *Broadband and audiovisual communication systems and terminals.*
- ITU-T Recommendation H.320 (1996), *Narrow-band visual telephone systems and terminal equipment.*
- ITU-T Recommendation H.324 (1996), *Terminal for low bit rate multimedia communication.*
- ITU-T Recommendation I.320 (1993), *ISDN protocol reference model.*
- CCITT Recommendation I.321 (1991), *B-ISDN protocol reference model and its application.*
- ITU-T Recommendation I.361 (1995), *B-ISDN ATM layer specification.*
- ITU-T Recommendation I.363.1 (1996), *B-ISDN ATM adaptation layer specification – Types 1 and 2 AAL.*
- ITU-T Recommendation I.363-3 (1996), *B-ISDN ATM adaptation layer specification – Types 3/4 AAL.*
- ITU-T Recommendation I.363.5 (1996), *B-ISDN ATM adaptation layer specification – Type 5 AAL.*
- ITU-T Recommendation I.365.1 (1993), *B-ISDN ATM adaptation layer sublayers: Frame relaying service specific convergence sublayer (FR-SSCS).*
- ITU-T Recommendation I.365.3 (1995), *B-ISDN ATM adaptation layer sublayers: Service specific coordination function to provide the connection-oriented transport service.*
- ITU-T Recommendation I.430 (1995), *Basic user-network interface – Layer 1 specification.*
- ITU-T Recommendation I.431 (1993), *Primary rate user-network interface – Layer 1 specification.*
- ITU-T Recommendation I.432.1 (1996), *B-ISDN user-network interface – Physical layer specification – General characteristics.*
- ITU-T Recommendation I.432.2 (1996), *B-ISDN user-network interface – Physical layer specification – 155 520 kbit/s and 622 080 kbit/s operation.*
- ITU-T Recommendation I.432.3 (1996), *B-ISDN user-network interface – Physical layer specification – 1544 kbit/s and 2048 kbit/s operation.*
- ITU-T Recommendation I.432.4 (1996), *B-ISDN user-network interface – Physical layer specification – 51 840 kbit/s operation.*
- ITU-T Recommendation Q.920 (1993), *ISDN user-network interface data link layer – General aspects.*



## Superseded by a more recent version

- ITU-T Recommendation Q.921 (1993), *ISDN user-network interface – Data link layer specification*.
- CCITT Recommendation Q.922 (1992), *ISDN data link layer specification for frame mode bearer services*.
- ITU-T Recommendation Q.931 (1993), *ISDN user-network interface layer 3 specification for basic call control*.
- ITU-T Recommendation Q.933 (1995), *Signalling specifications for frame mode switched and permanent virtual connection control and status monitoring*.
- ITU-T Recommendation Q.2110 (1994), *B-ISDN ATM adaptation layer – Service Specific Connection Oriented Protocol (SSCOP)*.
- ITU-T Recommendation Q.2130 (1994), *B-ISDN signalling ATM adaptation layer – Service Specific Coordination Function for support of signalling at the User-Network Interface (SSCF at UNI)*.
- ITU-T Recommendation Q.2931 (1995), *Digital Subscriber Signalling System No. 2 – User-Network Interface UNI layer 3 specification for basic call/connection control*.
- CCITT Recommendation T.90 (1992), *Characteristics and protocols for terminals for telematic services in ISDN*.
- ITU-T Recommendation T.120 (1996), *Data protocols for multimedia conferencing*.
- ITU-T Recommendation T.122 (1993), *Multipoint communication service for audiographics and audiovisual conferencing service definition*.
- ITU-T Recommendation T.124 (1995), *Generic conference control*.
- ITU-T Recommendation T.125 (1994), *Multipoint communication service protocol specification*.
- ITU-T Recommendation T.126 (1995), *Multipoint still image and annotation protocol*.
- ITU-T Recommendation T.127 (1995), *Multipoint binary file transfer protocol*.
- CCITT Recommendation V.7 (1988), *Definition of terms concerning data communication over the telephone network*.
- ITU-T Recommendation V.8 (1994), *Procedures for starting sessions of data transmission over the general switched telephone network*.
- ITU-T Recommendation V.8 bis (1996), *Procedures for the identification and selection of common modes of operation between Data Circuit-terminating Equipment (DCEs) and between Data Terminal Equipments (DTEs) over the general switched telephone network and on leased point-to-point telephone-type circuits*.
- ITU-T Recommendation V.14 (1993), *Transmission of start-stop characters over synchronous bearer channels*.
- ITU-T Recommendation V.34 (1996), *A modem operating at data signalling rates of up to 33 600 bit/s for use on the general switched telephone network and on leased point-to-point 2-wire telephone-type circuits*.
- ITU-T Recommendation V.42 (1996), *Error-correcting procedures for DCEs using asynchronous-to-synchronous conversion*.
- CCITT Recommendation V.42 bis (1990), *Data compression procedures for Data Circuit-terminating Equipment (DCE) using error correction procedures*.
- ITU-T Recommendation V.61 (1996), *A simultaneous voice plus data modem, operating at a voice+data signalling rate of 4800 bit/s with optional automatic switching to data-only signalling rates of up to 14 400 bit/s, for use on the General Switched Telephone Network and on leased point-to-point 2-wire telephone type circuits*.
- ITU-T Recommendation V.70 (1996), *Procedures for the simultaneous transmission of data and digitally encoded voice signals over the GSTN, or over a 2-wire leased point-to-point telephone-type circuit*.
- ITU-T Recommendation V.120 (1996), *Support by an ISDN of data terminal equipment with V-Series type interfaces with provision for statistical multiplexing*.

## Superseded by a more recent version

- CCITT Recommendation X.21 (1992), *Interface between data terminal equipment and data circuit-terminating equipment for synchronous operation on public data networks.*
- CCITT Recommendation X.21 bis (1988), *Use on public data networks of Data Terminal Equipment (DTE) which is designed for interfacing to synchronous V-Series modems.*
- ITU-T Recommendation X.25 (1996), *Interface between Data Terminal Equipment (DTE) and Data Circuit-terminating Equipment (DCE) for terminals operating in the packet mode and connected to public data networks by dedicated circuit.*
- ITU-T Recommendation X.200 (1994), *Information technology – Open Systems Interconnection – Basic Reference Model: The Basic Model.*
- ITU-T Recommendation X.213 (1995), *Information technology – Open Systems Interconnection – Network service definition.*
- ITU-T Recommendation X.214 (1995), *Information technology – Open Systems Interconnection – Transport service definition.*
- ITU-T Recommendation X.224 (1995), *Information technology – Open Systems Interconnection – Protocol for providing the connection-mode transport service.*
- ISO/IEC 3309:1993, *Information technology – Telecommunications and information exchange between systems – High-level Data Link Control (HDLC) procedures – Frame structure.*
- ISO/IEC 7776:1995, *Information technology – Telecommunications and information exchange between systems – High-level data link control procedures – Description of the X.25 LAPB-compatible DTE data link procedures.*
- ISO/IEC 8208:1995, *Information technology – Data communications – X.25 Packet Layer Protocol for Data Terminal Equipment.*
- ISO/IEC TR 8802-1:1997, *Information technology – Telecommunications and information exchange between systems – Local and metropolitan area networks – Specific requirements – Part 1: Overview of Local Area Network Standards.*

### 3 Definitions

This Recommendation uses the following terms defined in Recommendation F.701:

- Audiographic conference service;
- Multipoint control unit.

This Recommendation uses the following terms defined in Recommendation I.320:

- Control plane;
- User plane.

This Recommendation uses the following term defined in Recommendation Q.920:

- Data link connection identifier.

This Recommendation uses the following term defined in Recommendation Q.922:

- Synchronization and convergence function.

This Recommendation uses the following term defined in Recommendation V.7:

- Start-stop transmission.

This Recommendation uses the following term defined in Recommendations X.214 and X.213:

- Quality of service.

# Superseded by a more recent version

## 4 Abbreviations

This Recommendation uses the following abbreviations:

AAL	ATM Adaptation Layer
AL	Adaptation Layer
ATM	Asynchronous Transfer Mode
B-ISDN	Broadband Integrated Services Digital Network
CPCS	Common Part Convergence Sublayer
CSDN	Circuit Switched Data Network
DCE	Data Circuit-terminating Equipment
DLCI	Data Link Connection Identifier
DTE	Data Terminal Equipment
FCS	Frame Check Sequence
ISDN	Integrated Services Digital Network
LAN	Local Area Network
MCS	Multipoint Communication Service
MCSAP	MCS service Access Point
MCU	Multipoint Control Unit
NSAP	Network Service Access Point
OSI	Open Systems Interconnection
PES	Packetized Elementary Stream
PDU	Protocol Data Unit
PSDN	Packet Switched Data Network
PSTN	Public Switched Telephone Network
QOS	Quality of Service
SCF	Synchronization and Convergence Function
SDU	Service Data Unit
TPDU	Transport Protocol Data Unit
TSAP	Transport Service Access Point
VC	Virtual Channel

## 5 Multipoint configuration

A multipoint configuration is created from point-to-point connections between three or more terminals and MCUs. Figure 1 shows a typical configuration where terminals are connected in a multipoint star around each MCU. It also shows how MCUs may be interconnected to form a larger conference.

Figure 2 shows the framework of the T.120 protocol suite. This Recommendation defines the network specific protocols in any direct connection between terminal and MCU, between two terminals, or between two MCUs.

The point-to-point connections to a single MCU need not have identical communication profiles. Operation of the MCS protocol layer supports communication across different networks.

If two terminals lack a common profile, they cannot be connected directly to one another. In that case, an MCU may serve as an intermediary making communication possible. This is a special example of multipoint configuration.

# Superseded by a more recent version

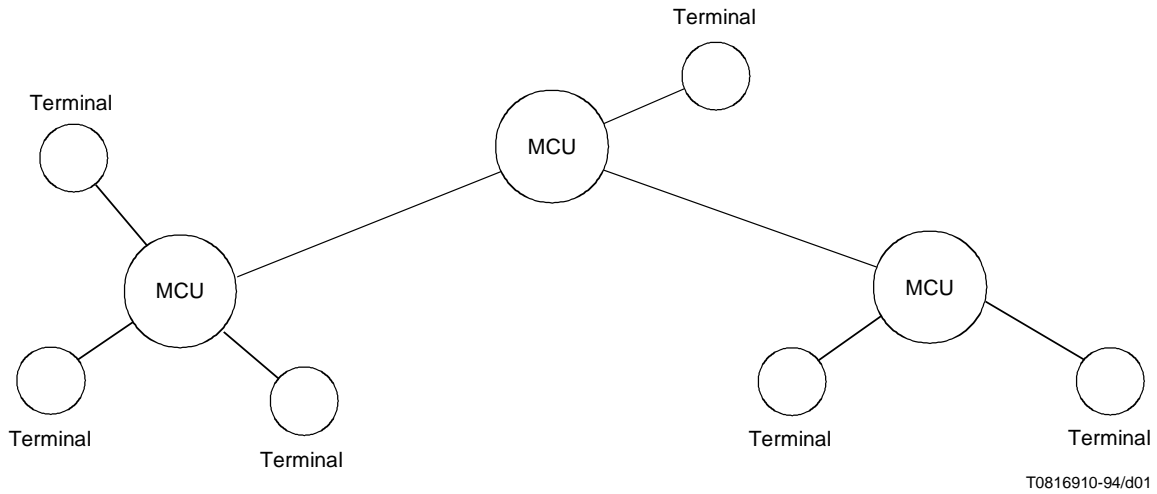

Figure 1/T.123 – Typical multipoint configuration

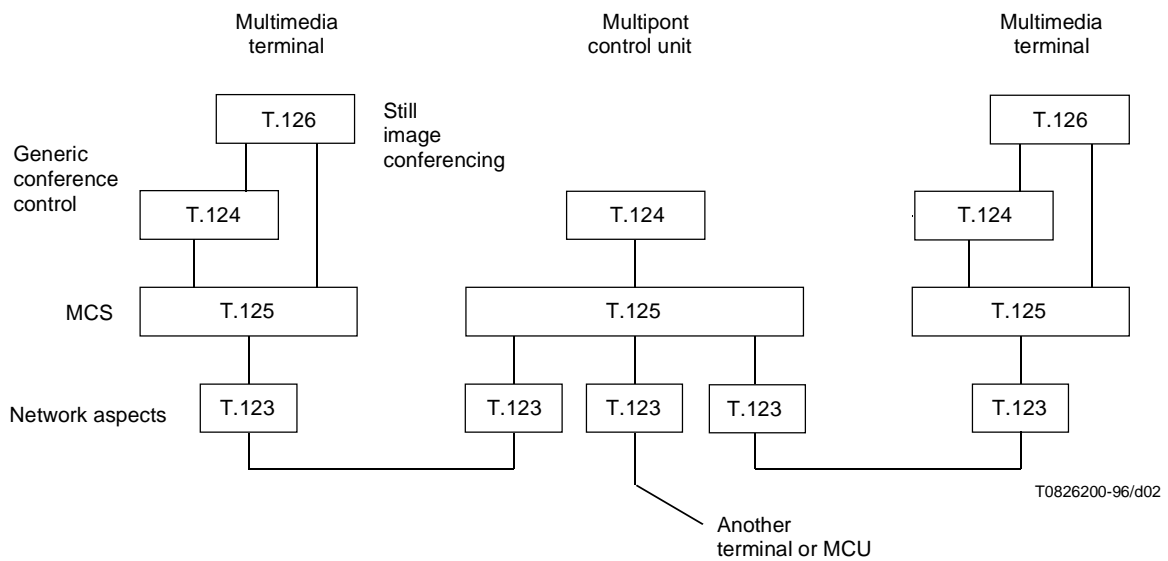
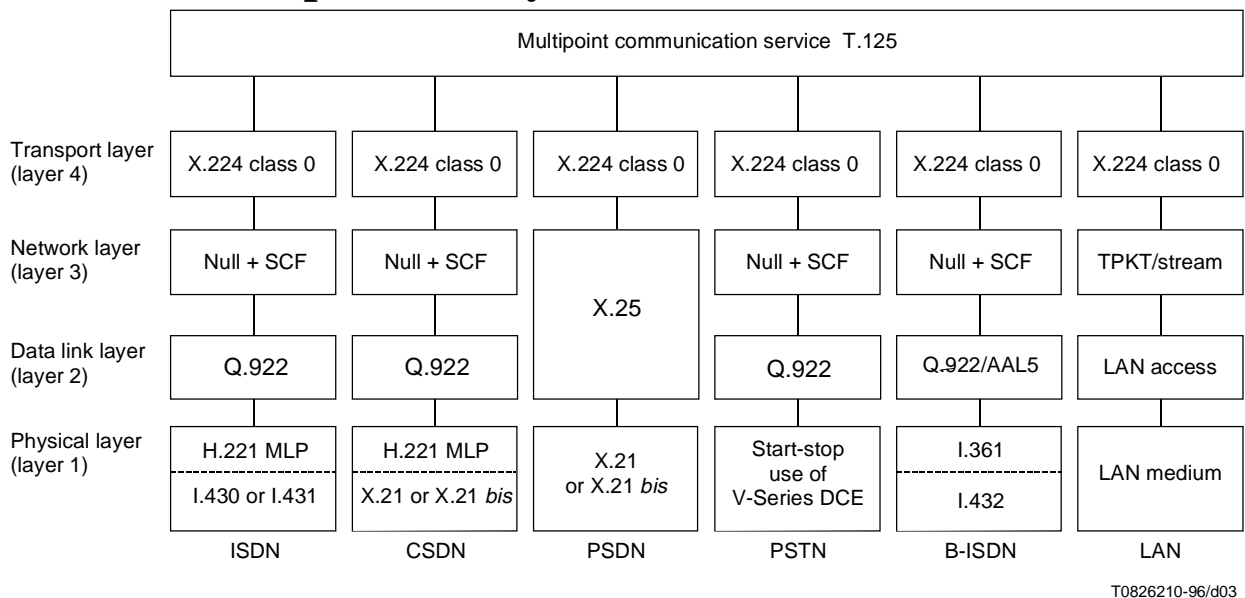

Figure 2/T.123 – Framework of the T.120 protocol suite

## 6 Profile overview

The general structure of the network specific profiles is shown in Figure 3. Profiles are defined in detail in the following clauses.

## Superseded by a more recent version



**Figure 3/T.123 – Basic profiles general structure**

NOTE – The use of Recommendation Q.922 over ISDN does not imply the use of a frame relay bearer service. Recommendation Q.922 is used to enhance the quality of service provided by the physical layer of an ISDN, CSDN, PSTN, or B-ISDN. This Recommendation exploits the error recovery mechanisms of Q.922 multiframe acknowledged mode for operation of one or more data links over a point-to-point connection provided by the corresponding network.

The service MCS requires from lower layers is the reliable, sequential, flow-controlled transfer of data units of unlimited size. One MCS connection consists of between one and four transport connections. The number depends on how many MCS data transfer priorities are implemented distinctly.

Multiple transport connections are derived from a point-to-point connection over a specific network by multiplexing in some lower protocol layer. This occurs at layer 2 for those cases where Q.922 is used and at layer 3 where X.25 or a LAN protocol is used.

Figure 4 shows the location of an MCS provider in the OSI reference model. An MCS provider exchanges MCS protocol data units with remote MCS providers. For this purpose, it uses transport-layer services. An MCS provider communicates with MCS users through an MCSAP by means of the MCS primitives defined in Recommendation T.122.

To simplify the address information that must be supplied when establishing an MCS connection, it is recommended that terminals and MCUs be administered so that null NSAP and TSAP selectors will resolve to a default MCS provider at the destination system.

This does not preclude the possibility that a specific selector may be required to reach an MCS provider in a particular context. This may be the case, for example, if the data connection is to be associated with an audio or video connection that is established independently. It may also be the case if the MCS connection is to join a conference hosted in one partition of a large MCU. Ideally, the specific selector to be used will be communicated dynamically through some prior exchange.

NOTE 1 – An NSAP selector may occur in the domain specific part of an NSAP address. The format for this is not standardized.

NOTE 2 – In each of the profiles specified here, the transport layer protocol is X.224. It conveys TSAP selectors as TSAP-ID parameters of connection establishment TPDUs.

# Superseded by a more recent version

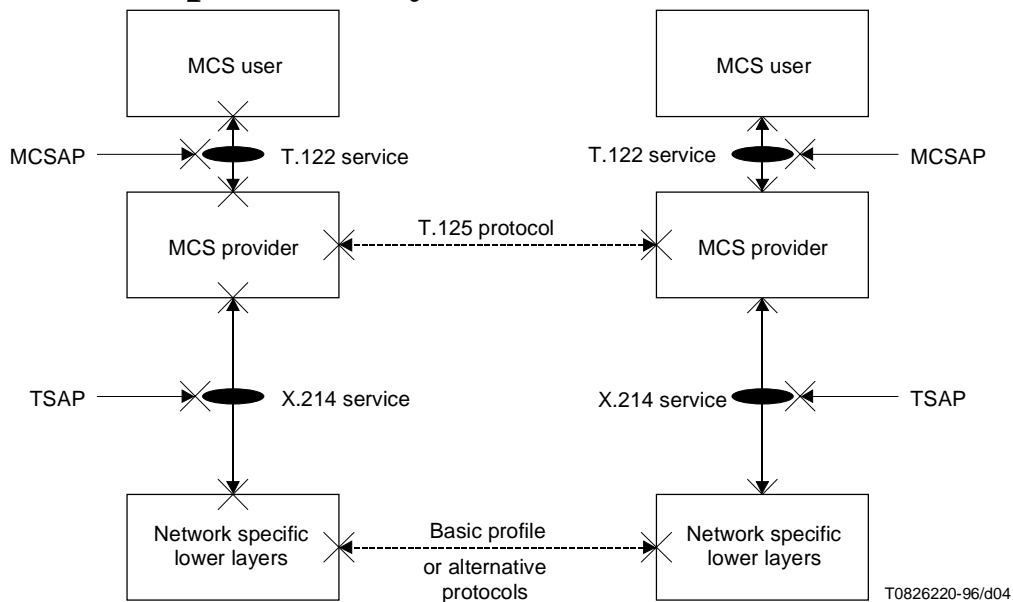

Figure 4/T.123 – Location of an MCS provider in the OSI reference model

## 7 Basic profiles

When call set-up protocols or audio and video are shown in the profiles that follow, it is only to aid understanding. They are not a normative part of this Recommendation.

### 7.1 ISDN basic profile

Figure 5 defines the ISDN basic profile.

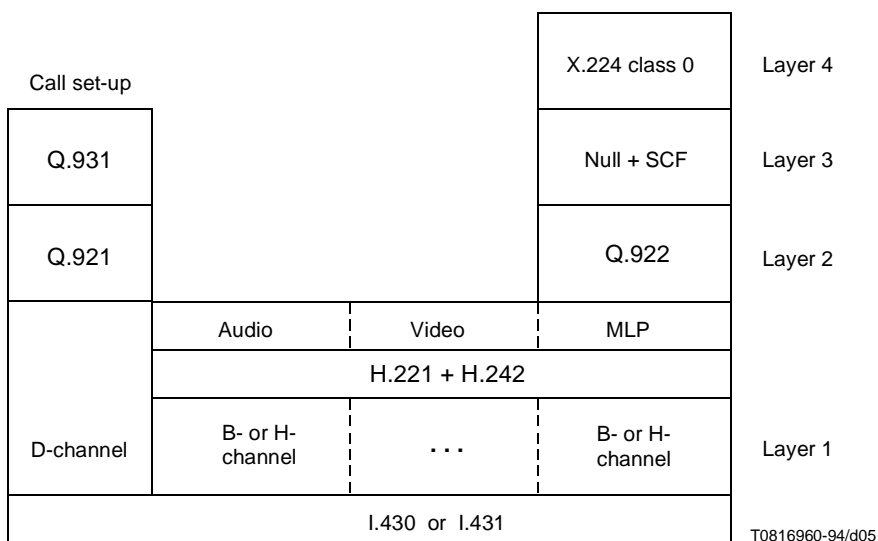

Figure 5/T.123 – ISDN basic profile

# Superseded by a more recent version

## Layer 4

- X.224.
- Class 0 preferred, no alternative class.
- Maximum TPDU size shall not exceed Layer 2 parameter N201.

## Layer 3

- User plane: null (no extra protocol during data transfer).
- Control plane: SCF as specified in clause 9.

## Layer 2

- Q.922.
- Protocol parameters and options as specified in clause 10.

## Layer 1

Sublayer formed by H.221 MLP channels:

- As specified in clause 12.

Sublayer formed by ISDN:

- 1-6 B-channels, or 1-5 H0-channels, or 1 H1-channel.
- Unrestricted digital information, optionally with tones and announcements.
- B-channels may be rate-adapted to 56 kbit/s for restricted networks.
- D-channel is used for network signalling only, not for user data.

NOTE – This Recommendation does not specify call set-up in the ISDN (although possible scenarios are illustrated in Appendix I). The SCF shown here operates only in the MLP channel, after ISDN call set-up and H.242 mode switching have occurred.

## 7.2 CSDN basic profile

Figure 6 defines the CSDN basic profile. Layers above H.221 are identical to the ISDN basic profile.

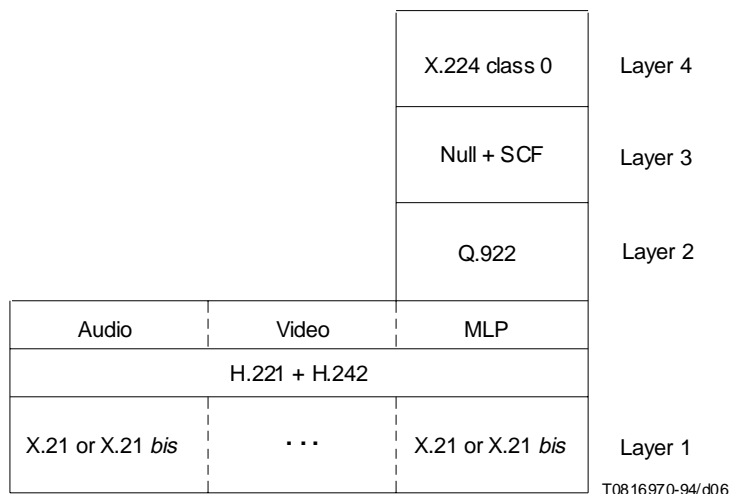

Figure 6/T.123 – CSDN basic profile

# Superseded by a more recent version

## Layer 4

- As specified in 7.1.

## Layer 3

- As specified in 7.1.

## Layer 2

- As specified in 7.1.

## Layer 1

Sublayer layer formed by H.221 MLP channels:

- As specified in clause 12.

Sublayer formed by CSDN:

- X.21 or X.21 *bis* for each circuit switched connection.
- Bit rates shall be a uniform multiple of 64 kbit/s or 56 kbit/s.

### 7.3 PSDN basic profile

Figure 7 defines the PSDN basic profile.

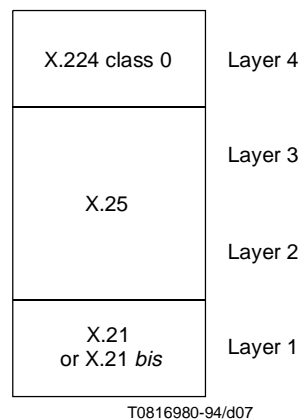

Figure 7/T.123 – PSDN basic profile

## Layer 4

- X.224.
- Class 0 preferred, no alternative class.

## Layer 3

- X.25 virtual call service.

## Layer 2

- X.25 LAPB single link procedure.

## Layer 1

- X.21 or X.21 *bis*.

### 7.4 PSTN basic profile

Figure 8 defines the PSTN basic profile. Layers above Q.922 are identical to the ISDN basic profile.



# Superseded by a more recent version

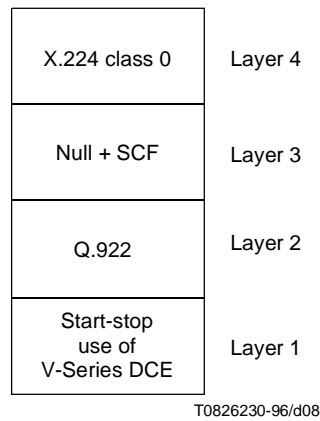

**Figure 8/T.123 – PSDN basic profile**

## *Layer 4*

- As specified in 7.1.

## *Layer 3*

- As specified in 7.1.

## *Layer 2*

- Q.922.
- Protocol parameters and options as specified in clause 10.
- Modified frame transparency based on ISO 3309, as specified in clause 11.

## *Layer 1*

- Start-stop transmission by DTE.
- When using V.14: one start bit, one stop bit, eight data bits, no parity.
- Any compatible V-Series DCE operating over PSTN may be employed.
- The DTE and DCE may be logical functions that are not physically separated, if integrated equipment can produce the same transmitted signals.
- The choice of V-Series DCE is unrestricted and includes, for example, V.34, V.61, and V.70 modems, with optional use of V.42 and V.42 *bis*. Selection of a compatible operating mode may be assisted by V.8 or V.8 *bis*.

NOTE 1 – If the error control function of V.42 is activated, system parameters should be set to avoid adverse interaction with the error correcting operation of Q.922. Important elements are the acknowledgement timer, the maximum number of octets in an information field, and the data forwarding conditions.

NOTE 2 – The effectiveness of V.42 *bis* data compression will vary, depending on how much of the application data exchanged in a conference has already been compressed by other means.

## **7.5 B-ISDN basic profile**

Figure 9 defines the B-ISDN basic profile. Layers above Q.922 are identical to the ISDN basic profile.

# Superseded by a more recent version

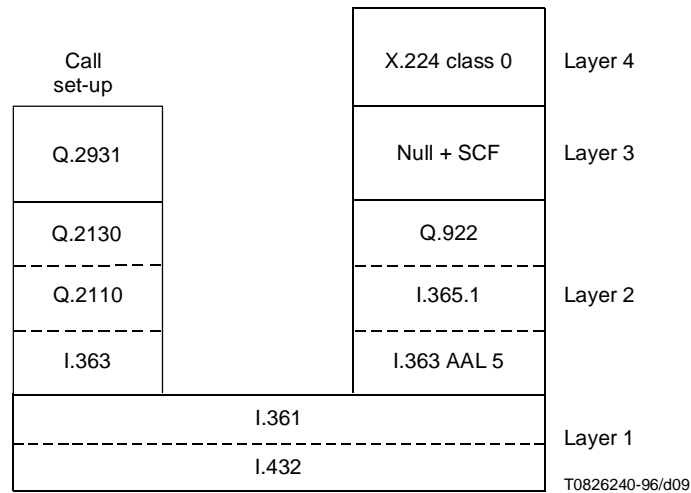

**Figure 9/T.123 – B-ISDN basic profile**

*Layer 4*

- As specified in 7.1.

*Layer 3*

- As specified in 7.1.

*Layer 2*

- Q.922.
- Protocol parameters and options as specified in clause 10.
- PDU structure defined in Figure 3/I.365.1 (no use of flags, transparency, or FCS).
- PDU octets conveyed as one CPCS-SDU using AAL type 5.

*Layer 1*

- ATM virtual channel.

## 7.6 LAN basic profile

Figure 10 defines the LAN basic profile.

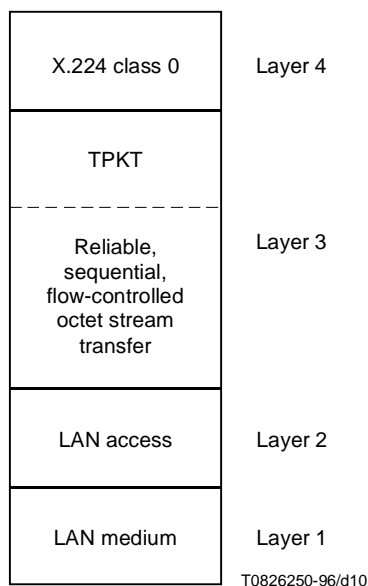

**Figure 10/T.123 – LAN basic profile**

# Superseded by a more recent version

## Layer 4

- X.224.
- Class 0 preferred, no alternative class.
- Default TPDU size 65531, but smaller values may be negotiated.

## Layer 3

- Packet header to delimit TPDU as specified in clause 8.
- Connection oriented service preserving octet sequence.
- Boundary between data units *not* retained as part of the transfer.
- Residual error rate low enough to use as a Type A network service.
- Flow control mechanism to exert back-pressure on a transmitter.

NOTE 1 – TPKT is required because an octet-stream service does not mark where data unit boundaries occur.

NOTE 2 – The following specify a layered protocol for octet stream transfer that is an example of the above:

- RFC 791, 792, 919, 922, 950, 1112, *Internet protocol*.
- RFC 793, *Transmission control protocol*.
- By default, destination port number 1503 per RFC 1700, *Assigned numbers*, but others may be used.

## Layer 2

- Commonly, ISO 8802 logical link control and medium access sublayers.

## Layer 1

- Commonly, ISO 8802 physical medium.

## 8 Packet header to delimit data units in an octet stream

Recommendation X.224 expects information to be transmitted and received in discrete units termed Network Service Data Units (NSDUs), which can be an arbitrary sequence of octets. Although other classes of the transport protocol may combine more than one TPDU inside a single NSDU, X.224 class 0 does not use this facility. Hence, in the context of T.123 protocol stacks, a TPDU may be identified with its underlying NSDU.

A fundamental difference between the network service expected by Recommendation X.224 and an octet stream transfer service, as characterized in 7.6, is that the latter conveys a continuous sequence of octets with no explicit boundaries between related groups of octets.

This clause specifies a distinct protocol layer to repair the discrepancy and meet the needs of Recommendation X.224. It defines a simple packet format whose purpose is to delimit TPDU. Each packet, termed a TPKT, is a unit composed of an integral number of octets, of variable length.

A TPKT consists of two parts: a packet-header, followed by a TPDU. The format of the packet-header is constant, independent of the type of TPDU. The packet-header consists of four octets as shown in Figure 11.

Octet 1 is a version number, with binary value 0000 0011. Octet 2 is reserved for further study. Octets 3 and 4 are the unsigned 16-bit binary encoding of the TPKT length. This is the length of the entire packet in octets, including both the packet-header and the TPDU.

Since an X.224 TPDU occupies at least 3 octets, the minimum value of TPKT length is 7. The maximum value is 65535. This permits a maximum TPDU size of 65531 octets.

NOTE – This description of the TPKT protocol layer agrees with RFC 1006, *ISO transport service on top of the TCP*.

# Superseded by a more recent version

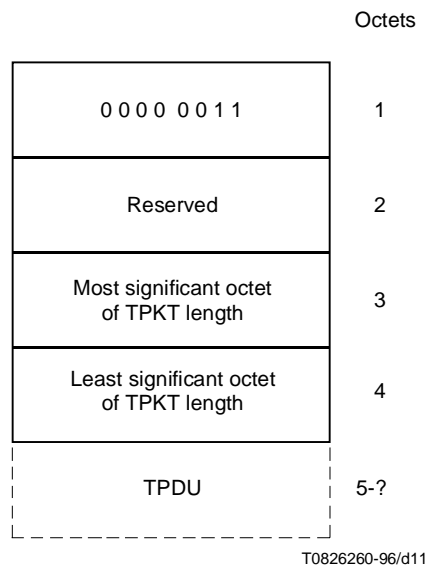

**Figure 11/T.123 – Format of the TPKT packet-header**

## 9 Synchronization and convergence function

### 9.1 SCF overview

The SCF resides in the network layer of each communication profile whose data link layer is specified to be Q.922. It coordinates network connection establishment and release between the control plane and the user plane as described in clause 4/Q.922. The purpose of the SCF is to provide network services to the transport layer. Figure 12 is the architectural model of the SCF.

Network services required by the X.224 transport protocol are listed in Table 1. This table is derived from Table 2/X.224 by excluding optional features and N-RESET (because N-RESET is never requested, according to Table A.3/X.224, and any indication of it can be escalated to N-DISCONNECT).

**Table 1/T.123 – Network services required by X.224**

Primitives	Parameters
N-CONNECT request N-CONNECT indication	Called address Calling address QOS parameter set
N-CONNECT response N-CONNECT confirm	Responding address QOS parameter set
N-DATA request N-DATA indication	NS user data
N-DISCONNECT request N-DISCONNECT indication	

# Superseded by a more recent version

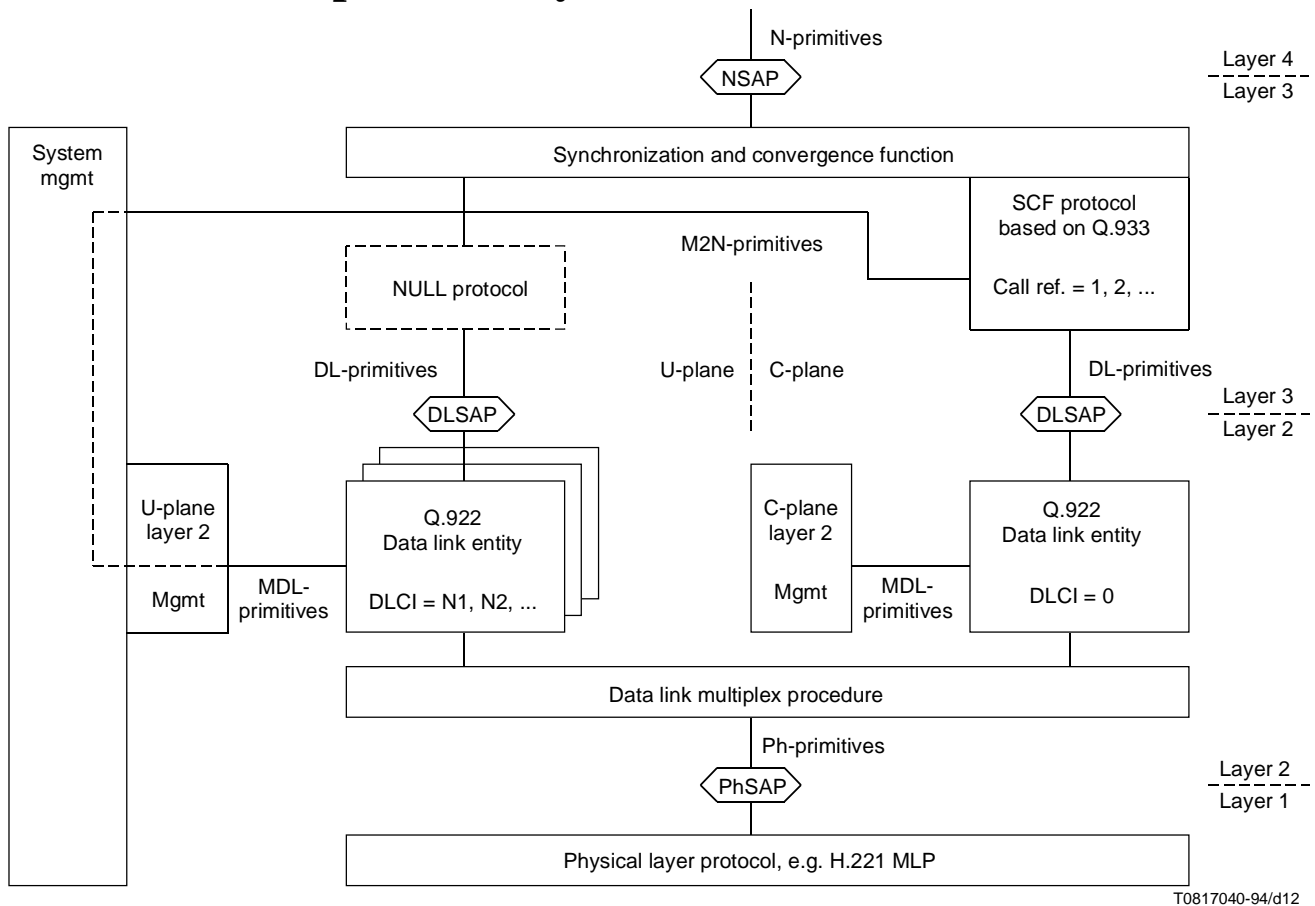

**Figure 12/T.123 – Architectural model of the SCF**

The SCF implements the N-CONNECT and N-DISCONNECT primitives. During data transfer it is inactive, and N-DATA maps directly to DL-DATA with no extra protocol. This requires that the transport layer limits the size of its TPDU's to one Q.922 I frame.

Recommendation Q.922 supports multiple data link connections distinguished by DLCI. Acting through layer 2 management, the SCF controls DLCI assignments. It communicates with a peer SCF by sending and receiving Q.933 messages over DLCI 0, which is reserved for in-channel signalling. DLCI 0 serves the control plane, supporting SCF control. Other DLCIs serve the user plane, supporting data transfer.

SCF procedures are based on those specified in Recommendation Q.933, in which are defined a case A covering circuit switched access to a remote frame handler and a case B covering integrated access to a local frame handler. The SCF use of Q.933 messages may be considered a new case C covering circuit switched access directly to another network user. This new case C does not use DLCIs to distinguish connections to different destinations. It uses DLCIs to distinguish multiple connections between the same two end points. Each such connection may have a different quality of service.

The sequence of actions to obtain a physical circuit between two users can vary with the communication profile and other circumstances. A circuit may be established without the aid of SCF, prior to the first N-CONNECT request and indication. When these primitives are finally invoked, called and calling addresses may be omitted or ignored. Alternatively, N-CONNECT request may initiate events, and network addresses may be required for circuit routing.

# Superseded by a more recent version

## 9.2 SCF procedures

The SCF shall act as a network user required to act for Q.933 case A of Frame Relaying. It shall behave as though connected semi-permanently to a remote frame handler, even though the bit rate allotted to the physical circuit may not be exactly an ISDN information transfer rate.

The sole exception is 5.6/Q.933 concerning DLCI collisions. To maintain a symmetric relationship between two network users, the SCF shall give neither direction preference as incoming. Instead, it shall resolve collisions by forcing new DLCI selections on both sides, as specified in detail below.

The SCF shall obey the additional requirements stated in the remainder of this subclause.

As soon as a duplex physical circuit is activated, the SCF shall assign and establish DLCI 0 to serve the control plane. DLCI 0 shall carry Q.933 messages in Q.922 I frames. If DLCI 0 is ever re-established, which indicates a protocol error, the SCF shall cause it to be released. If DLCI 0 is ever released, the SCF shall remove all other DLCIs assigned to the physical circuit and shall indicate that their data links are disconnected. The SCF may then attempt to establish DLCI 0 again and reinitialize Q.933 signalling.

As a positive response to SETUP, the SCF shall transmit CONNECT, and this shall be answered by CONNECT ACKNOWLEDGE. In this situation there is no advantage in transmitting ALERTING, CALL PROCEEDING, or PROGRESS. If received, these messages may be ignored.

The negative response to SETUP shall be RELEASE COMPLETE. This is also the simplest means of clearing an active call. In this situation there is no advantage in transmitting DISCONNECT, STATUS, or STATUS ENQUIRY. If received, these messages may stimulate the transmission of RELEASE COMPLETE. If RELEASE is received during most call states specified in Recommendation Q.933, e.g. while the call is active but not while awaiting a response to SETUP or RELEASE, it shall cause the transmission of RELEASE COMPLETE. Although an unexpected RELEASE COMPLETE is considered a message sequence error, it achieves the intended effect of forcing the receiver to clear a call.

Figure 13 shows the messages exchanged and primitives invoked during a successful N-CONNECT. This figure assumes that DLCI 0 is already established, as the result of exchanging SABME and UA when the physical circuit was activated.

The SCF shall employ one-octet call reference values (ranging from 1 to 127 on each side) and two-octet DLCI values (comprising 10 bits). DLCIs shall be selected randomly within the range allotted by Recommendation Q.922 for support of user information, namely, from 16 to 991 inclusive.

An SCF processing N-CONNECT request shall propose a preferred DLCI value in SETUP. An SCF receiving SETUP shall consider the DLCI value it contains. It is an error if the DLCI value is already assigned. If the receiving SCF has proposed the same DLCI value in an unanswered SETUP, it shall respond RELEASE COMPLETE with cause number 44 *requested circuit/channel not available*. Otherwise it shall accept the received DLCI value. Its response to SETUP shall then depend on a consideration of other parameters and the will of the network user. If the response is positive, the same DLCI value shall be returned in CONNECT; if negative, a cause number other than 44 shall be returned in RELEASE COMPLETE. An SCF receiving a response of RELEASE COMPLETE with cause 44 shall retry its failed SETUP with a new randomly selected DLCI value. If the number of retries seems excessive, the SCF may choose to reseed its random number generator. An SCF receiving a response of RELEASE COMPLETE with a cause number other than 44 shall indicate through N-DISCONNECT that the N-CONNECT request failed.

Figure 14 shows the messages exchanged and primitives invoked following a user-requested N-DISCONNECT. Note that DL-RELEASE request and the transmission of DISC are not required, because MDL-REMOVE on each side properly resets the state of the affected DLCI.

# Superseded by a more recent version

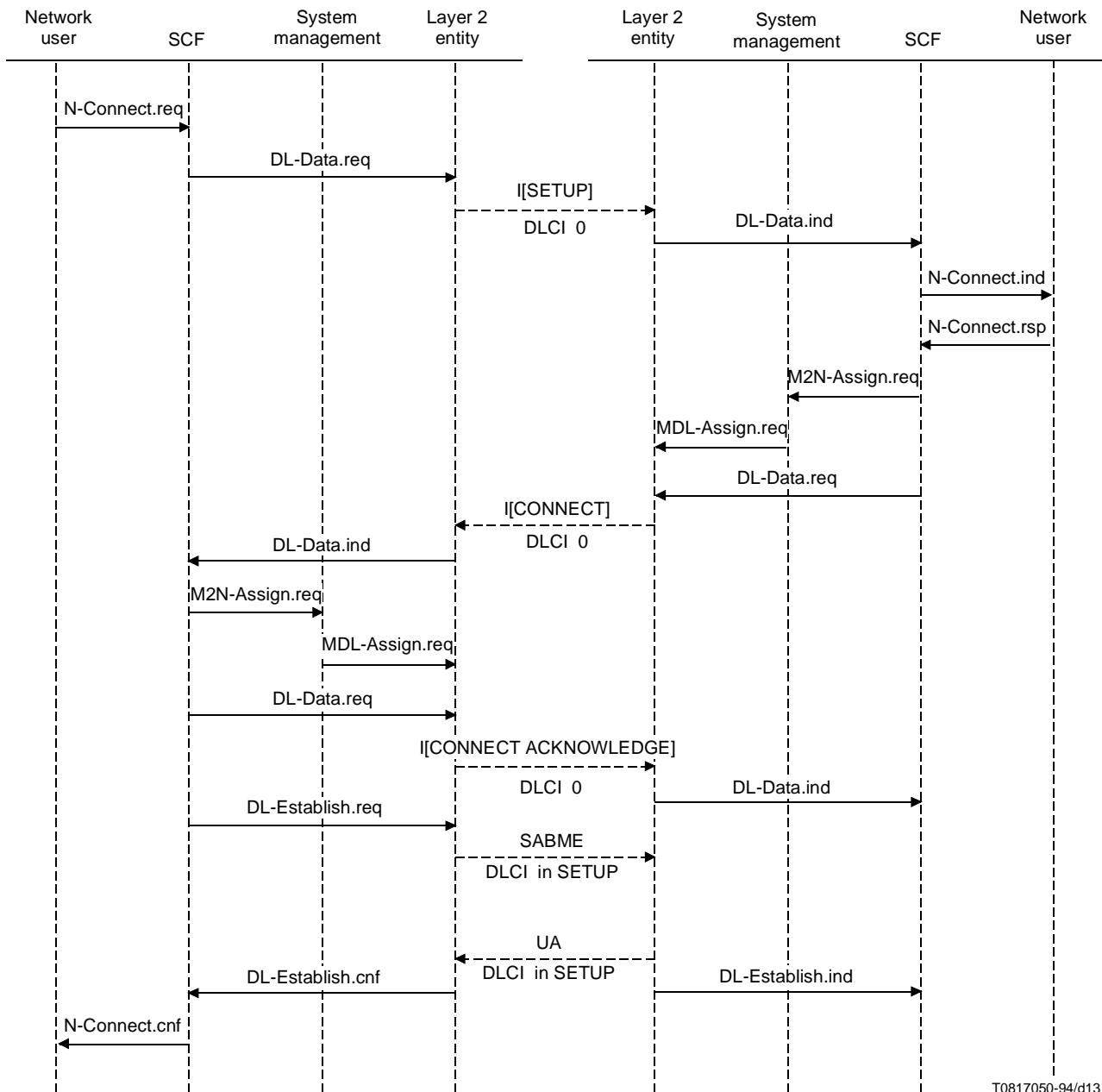

T0817050-94/d13

Figure 13/T.123 – Sequence of actions for N-CONNECT





# Superseded by a more recent version

**Table 2/T.123 – SETUP message content**

Information element	Type	Notes
Protocol discriminator	M	
Call reference	M	
Message type	M	
Bearer capability	M	Q.922
DLCI	M	Preferred
End-to-end transit delay	O	Cumulative, requested, maximum
Link layer core parameters	O	N201, throughput(s), minimum(s)
Link layer protocol parameters	O	k, T200
X.213 priority	O	Data priority, lowest acceptable
Calling party subaddress	O	NSAP address
Called party subaddress	O	NSAP address

**Table 3/T.123 – CONNECT message content**

Information element	Type	Notes
Protocol discriminator	M	
Call reference	M	
Message type	M	
DLCI	M	Exclusive
End-to-end transit delay	O	Cumulative
Link layer core parameters	O	N201, throughput(s)
Link layer protocol parameters	O	k, T200
Connected subaddress	O	NSAP address
X.213 priority	O	Data priority

**Table 4/T.123 – CONNECT ACKNOWLEDGE message content**

Information element	Type
Protocol discriminator	M
Call reference	M
Message type	M

# Superseded by a more recent version

Table 5/T.123 – RELEASE COMPLETE message content

Information element	Type
Protocol discriminator	M
Call reference	M
Message type	M
Cause	M

## 9.4 Quality of service parameters

Important characteristics of data transfer performance are throughput, transit delay, and priority. These are part of the QOS parameter set of N-CONNECT. QOS parameters are separate from but may influence the choice of protocol parameters. Parameters of both kinds may be conveyed by the SCF using optional information elements in SETUP and CONNECT.

Parameter negotiations shall obey the rules of 5.1.3.3/Q.933 and 5.2.3.3/Q.933.

Q.922 system parameters that may be negotiated are: k, N201, and T200. Their value shall be the same for both directions of transfer. If these parameters are not explicitly signalled, they shall take the default values of clause 10 below.

If QOS parameters are not explicitly signalled, the corresponding qualities are indeterminate and may take any values that are convenient for the service providers.

The QOS and protocol parameters in CONNECT, supplemented by any defaults, shall be final values for the assigned DLCI. The SCF shall pass these to the underlying layer 2 entity by M2N-ASSIGN, which emerges from the management plane as MDL-ASSIGN. This accords with 4.1.1.5/Q.922 and 4.1.1.10/Q.922, which note that additional optional parameters may be included in these primitives.

The QOS and protocol parameters of DLCI 0 are not explicitly signalled. The QOS shall implicitly equal or exceed that of any other DLCI. The protocol parameters k, N201, and T200 for DLCI 0 shall take the default values.

A layer 2 entity may or may not implement data priority as a QOS parameter. If it does, the relative priority of DLCIs should determine the order of servicing user data requests queued for transmission, assuming that their respective protocol states are equally ready. DLCIs of the same priority should be treated impartially.

The SCF shall express data priorities using the value encoding of the information element *X.213 priority* (which agrees with the encoding of the X.25 packet layer). The lowest priority shall be 0 and the highest shall be, at most, 14. Requested priorities shall be negotiated downward into the range of values, beginning with 0, that the underlying layer 2 entity can implement distinctly.

## 10 Q.922 protocol parameters and options

The address field format shall be two octets (10-bit DLCIs).

Three bits of the address field are reserved for use with frame relaying service: Forward Explicit Congestion Notification (FECN), Backward Explicit Congestion Notification (BECN), and Discard Eligibility (DE). These bits shall be set to 0 by the transmitter and shall be ignored by the receiver.

Information transfer shall be in I frames using the procedures of multiple frame acknowledged operation.

Frame types UI and XID shall not be transmitted.

# Superseded by a more recent version

System parameters are associated with each individual data link connection. Their values should be set taking into account characteristics of the underlying physical circuit. Default values are specified in Table 6.

**Table 6/T.123 – Data link default system parameter values**

System parameter	Default value	Parameter description
k	40	Maximum number of outstanding I frames
N200	10	Maximum number of retransmissions
N201	260	Maximum number of octets in an information field
T200	1.5 s	Retransmission timer
T203	30 s	Idle timer

Values of k, N201, and T200 can be negotiated by the SCF specified in clause 9. The values of N200 and T203 need not be communicated from transmitter to receiver and may be set locally on each side.

The default value of k is the maximum value cited in 5.9.4/Q.922 (for a link speed of 1536 - 1920 Mbit/s). This is also the value cited in Appendix VI/T.90, independent of the link speed, for optimum throughput with a packet size of 256 octets.

A value of k that is too large is better than a value that is too small. A Q.922 receiver need not accept a full window of I frames if buffers are scarce; it can set the *own receiver busy* condition at some intermediate point. Moreover, a Q.922 transmitter can voluntarily limit itself to a smaller number of outstanding I frames; it is not obliged to fill the window to maximum capacity. On the other hand, if k is set small and the window fills too quickly, a transmitter is required to cease. Throughput and response may suffer.

Appendix I/Q.933 suggests a procedure to negotiate the value of k using a formula that involves the data frame size in octets.

Implementors should consider the possibility of limiting frame size dynamically to a smaller value than system parameter N201 allows. This may require coordination with the transport layer that is forming TPDU's. It may be prudent to restrict the worst-case serial transmission time of lower priority data, so that newly queued data of higher priority can be serviced promptly. A maximum latency of 60 ms has been suggested.

The alternative option of aborting a low priority transmission already in progress may also be considered.

## 11 Data link frame structure transparency for start-stop transmission

Since start-stop transmission is organized as a sequence of octets, it is convenient to use an octet-stuffing scheme for data link frame structure transparency. This is a recognized alternative to the bit-stuffing scheme (insert a 0 bit after all sequences of five contiguous 1 bits) that is suitable for synchronous transmission. It makes the implementation of Q.922 for the PSTN profile easier and more efficient, especially when using the serial port of a typical personal computer.

For the PSTN case, 2.6/Q.922, which defines frame structure transparency by reference to Recommendation Q.921, shall not be implemented. In its place shall be implemented the following procedures taken from ISO/IEC 3309, 4.5.2:

The control escape octet is a transparency identifier that identifies an octet occurring within a frame to which the following transparency procedure is applied. The encoding of the escape octet is given in Figure 15.

## Superseded by a more recent version

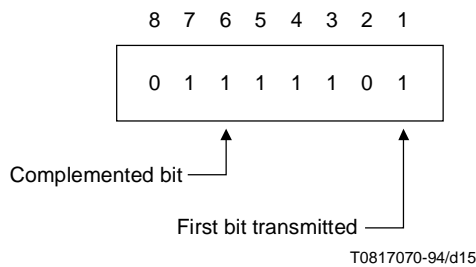

**Figure 15/T.123 – Control escape octet for start-stop transparency**

The transmitter shall examine the frame content between the opening and closing flag sequences including the address, control, and FCS fields and, following completion of the FCS calculation, shall:

- a) upon the occurrence of the flag or a control escape octet, complement the 6th bit of the octet; and
- b) insert a control escape octet immediately preceding the octet resulting from the above prior to transmission.

Other octet values may optionally be included in the transparency procedure by the transmitter.

The receiver shall examine the frame content between the two flag octets and shall, upon receipt of a control escape octet and prior to FCS calculation:

- a) discard the control escape octet; and
- b) restore the immediately following octet by complementing its 6th bit.

A frame that ends with a control escape octet followed by a closing flag is invalid and shall be ignored by the receiver (frame abort).

NOTE – This procedure does not preclude any particular character occurring within the transmitted data stream. In the case of separate DTE and DCE, flow control between them via command characters (XON/XOFF) must be disabled, because it cannot be distinguished from the DTE-to-DTE transmission of the same characters. For this Recommendation, in this case, flow control is a function of the Q.922 protocol.

## 12 Physical sublayer formed by H.221 MLP channels

Use of the H.221 MLP and H-MLP channels shall conform to the specifications of Recommendations H.221, H.230, H.233, H.242, and H.243 for the integration of multimedia signals:

- To determine a compatible mode of operation, H.242 capability exchange sequence A applies.
- All systems capable of MLP shall declare at least the common capability MLP-6.4k.
- Other MLP and H-MLP bit rates defined by Recommendation H.221 may also be declared.
- To establish or change mode, H.242 mode switching sequence B applies.
- Upon receipt of an H.221 command opening MLP or H-MLP, a system shall act to ensure that at least one of these is open in the opposite direction, so that full duplex communication may occur.
- The bit rates of MLP and H-MLP need not be the same in both directions of transmission, unless symmetry is explicitly commanded.
- H.230 command MCS (multipoint command symmetrical data transmission) applies to MLP and H-MLP, requiring that the outgoing bit rates be set equal to the incoming.

## Superseded by a more recent version

As suggested in 9.2/H.242, if both MLP and H-MLP are in force, their bit rates shall be combined to form a single serial stream. Bit positions shall be numbered horizontally across the synchronized H.221 framing of initial and additional channels, as illustrated in Tables 7 through 9.

H.221 commands to set the rate of MLP or H-MLP shall not disrupt the logical continuity of the combined serial stream. The input or output of bits shall simply continue in the next sub-multiframe at a modified rate. The operation of higher layer protocols will not be impacted unless the bit rate is reduced too low for a long period of time.

In particular, MLP or H-MLP or both may be turned off temporarily in the process of rearranging the bit rates of a multimedia multiplex. This by itself is not sufficient cause to disconnect Q.922 data links involuntarily. That step shall only be taken, in the absence of protocol-detected errors, upon receipt of the H.221 command T.120-off.

**Table 7/T.123 – Bit positions for MLP-6.4k,  
restricted, encryption active**

Initial channel							
1	2	3	4	5	6	7	8
						FAS	1 1 1
						BAS	1 1 1
						ECS	1 1 1
						M1	1
						M2	1
						•	1
						•	1
						M55	1
						M56	1
FAS Frame alignment signal BAS Bit-rate allocation signal ECS Encryption control signal							

# Superseded by a more recent version

Table 8/T.123 – Bit positions for MLP-6.4k plus H-MLP-62.4k

Initial channel								Additional channel							
1	2	3	4	5	6	7	8	1	2	3	4	5	6	7	8
							FAS	M1	M2	M3	M4	M5	M6	M7	
								M8	•	•	•	•	•	M14	FAS
								•	•	•	•	•	•	•	
							BAS	•	•	•	•	•	•	•	BAS
								M106	•	•	•	•	•	M112	
							M113	M114	•	•	•	•	•	M120	M121
							•	•	•	•	•	•	•	•	•
							•	•	•	•	•	•	•	•	•
							M680	•	•	•	•	•	•	•	M688

Table 9/T.123 – Bit positions for H-MLP-128k in an H0 channel

Time-slot 1	Time-slot 2	Time-slot 3	Time-slot 4	Time-slot 5	Time-slot 6
	M1 • • • M8	M9 • • • M16			
	M17 • • • •	• • • • M32			
	• • • •	• • • •			
	• • • •	• • • •			
	M1265 • • • •	• • • • M1280			

## 13 Alternative profiles

These alternatives are designed to allow point-to-point connections between terminals or MCUs in special circumstances. Their use may be specified in the system recommendation for a particular service or may be agreed bilaterally.

The set of alternative profiles is not complete and is not intended to be an exhaustive list of all possibilities.

No procedures are offered here by which terminals may discover the fact that they share a common profile, nor is any provision made for negotiation, in the event they share more than one. The coding of Q.931 or Q.2931 call control information elements can restrict the set of profiles that may be considered, but it cannot guarantee a successful outcome. Such concerns are part of a larger design, which may choose to reference this Recommendation.

### 13.1 Alternative: ISDN based on Recommendation Q.922

Figure 16 defines an alternative profile for ISDN based on Recommendation Q.922. When video is not required and audio can be assigned its own channel, this is a less expensive protocol stack to implement than H.221. Layers above the B- or H-channel are identical to the ISDN basic profile.

## Superseded by a more recent version

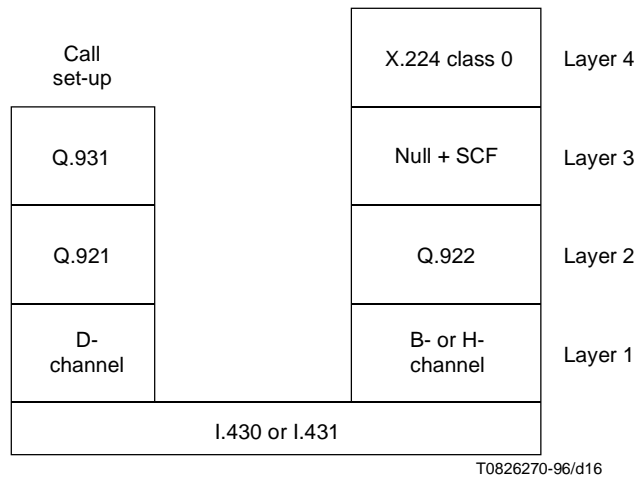

**Figure 16/T.123 – Alternative profile for ISDN based on Q.922**

### Layer 4

- As specified in 7.1.

### Layer 3

- As specified in 7.1.

### Layer 2

- As specified in 7.1.

### Layer 1

- One B-channel, one H0-channel, or one H1-channel.
- Some networks may also offer channels of intermediate bit rate.

## 13.2 Alternative: ISDN based on T.90

Figure 17 defines an alternative profile for ISDN based on Recommendation T.90. Though less efficient than Q.922, the X.25 protocol stack is more familiar as a component of telematic terminals.

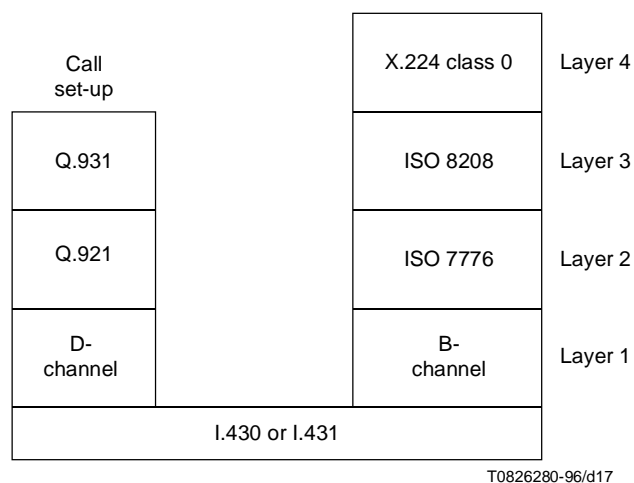

**Figure 17/T.123 – Alternative profile for ISDN based on Recommendation T.90**

# Superseded by a more recent version

## Layer 4

- X.224.
- Class 0 preferred, no alternative class.

## Layer 3

- DTE-DTE communication as specified in clause 2/T.90.

## Layer 2

- DTE-DTE communication as specified in clause 2/T.90.

## Layer 1

- DTE-DTE communication as specified in clause 2/T.90.

### 13.3 Alternative: ISDN based on Recommendation V.120

Figure 18 defines an alternative profile for ISDN based on Recommendation V.120. This protocol stack gives a typical personal computer access to ISDN speeds through a common terminal adaptor. Layers above the terminal adaption are identical to the PSTN basic profile.

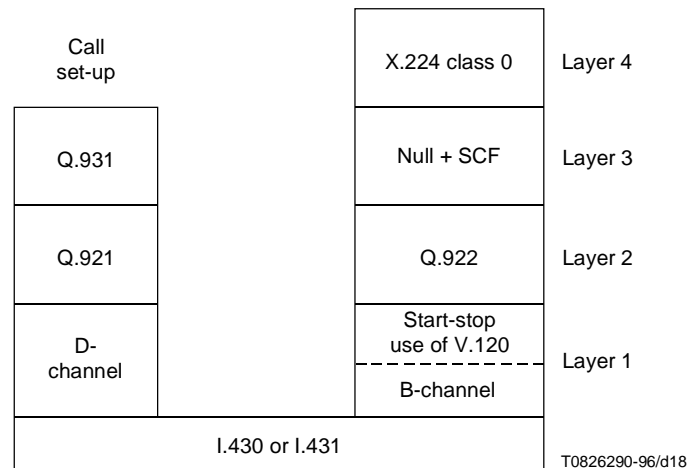

**Figure 18/T.123 – Alternative profile for ISDN based on Recommendation V.120**

## Layer 4

- As specified in 7.1.

## Layer 3

- As specified in 7.1.

## Layer 2

- As specified in 7.4.

## Layer 1

- Start-stop transmission by DTE.
- DCE as specified in V.120 asynchronous mode operation.
- The DTE and DCE may be logical functions that are not physically separated, if integrated equipment can produce the same transmitted signals.



# Superseded by a more recent version

## 13.4 Alternative: PSTN based on Recommendation H.324

Figure 19 defines an alternative profile for PSTN based on Recommendation H.324. This permits data conferencing to be widely deployed in conjunction with the PSTN videophone. Mapping Q.922 frames to AL-SDUs is a better use of scarce bandwidth than other possible framings. Layers above the adaptation are identical to the PSTN basic profile.

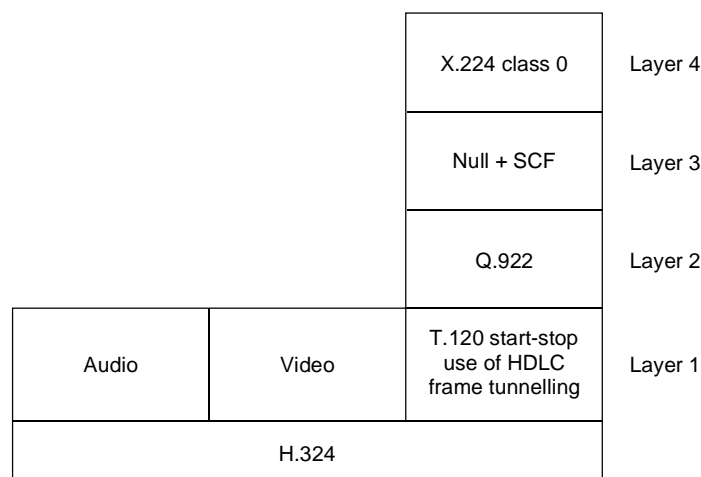

T0826300-96/d19

**Figure 19/T.123 – Alternative profile for PSTN based on Recommendation H.324**

### Layer 4

- As specified in 7.1.

### Layer 3

- As specified in 7.1.

### Layer 2

- As specified in 7.4.

### Layer 1

- Start-stop transmission by DTE.
- DCE as specified in H.324 HDLC frame tunnelling for Recommendation T.120.
- The DTE and DCE may be logical functions that are not physically separated, if integrated equipment can produce the same transmitted signals.

NOTE – The net effect is that the content of a Q.922 frame – including FCS but without flags or transparency – is conveyed as one AL-SDU using framed AL1 over an H.223 logical channel opened for the T.120 data application.

## 13.5 Alternative: B-ISDN based on Recommendation H.222

Figure 20 defines an alternative profile for B-ISDN based on Recommendation H.222. This protocol stack multiplexes audio, video, and data together over a single ATM virtual channel. Layers above Q.922 are identical to the ISDN basic profile.

## Superseded by a more recent version

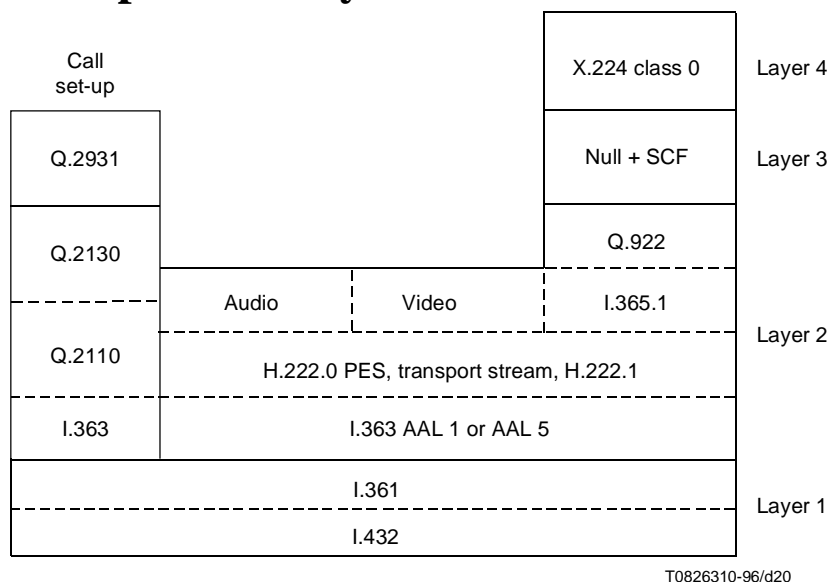

**Figure 20/T.123 – Alternative profile for B-ISDN based on Recommendation H.222**

### Layer 4

- As specified in 7.1.

### Layer 3

- As specified in 7.1.

### Layer 2

- Q.922.
- Protocol parameters and options as specified in clause 10.
- Modified frame structure: no use of flags or transparency.
- Each frame (address octets through FCS) conveyed as the data bytes of one PES packet in the H.222.1-defined data elementary stream for protocol type T.120 subchannel.
- Transport Stream transmission as specified in Recommendation H.222.1.

NOTE – The `payload_unit_start_indicator` classifies each Transport Stream packet as containing either the first segment or a continuation segment of a PES packet. If a segment is less than the maximum size, the difference is absorbed by stuffing bytes before the PES packet header to a total of 188 bytes.

### Layer 1

- ATM virtual channel.

## 13.6 Alternative: LAN based on data unit transfer

Figure 21 defines an alternative profile for LAN based on data unit transfer. By aligning TPDU's with data units of the underlying LAN, such a protocol stack can eliminate some buffer management. Though its segmentation feature may add nothing to what the LAN already offers, X.224 is recommended for uniformity and as a basis for future enhancements.

NOTE – No LAN protocol is named here, because the commercially important services are better known through their application programming interfaces. The protocols that support a service may be undisclosed or undocumented.

# Superseded by a more recent version

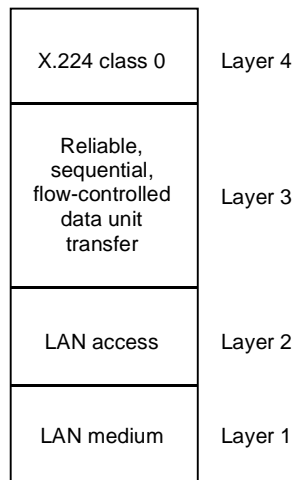

T0826320-96/d21

**Figure 21/T.123 – Alternative profile for LAN based on data unit transfer**

## *Layer 4*

- X.224.
- Class 0 preferred, no alternative class.
- Maximum TPDU size shall not exceed maximum LAN data unit.

## *Layer 3*

- Connection-oriented service preserving sequence.
- Boundary between data units retained as part of the transfer.
- Residual error rate low enough to use as a Type A network service.
- Flow control mechanism to exert back-pressure on a transmitter.

NOTE 1 – NETBIOS, Netware Sequenced Packet Exchange (SPX), and AppleTalk Data Stream Protocol (ADSP) are examples of the above.

NOTE 2 – In the case of SPX and ADSP, data unit boundaries are marked by setting an end-of-message bit.

## *Layer 2*

- Commonly, ISO 8802 logical link control and medium access sublayers.

## *Layer 1*

- Commonly, ISO 8802 physical medium.

## **Annex A**

### **Integration of multimedia signals framed according to Recommendation H.221**

Figure A.1 illustrates how Recommendation H.221 aggregates the throughput of one or more digital channels and then partitions the total transfer rate into bit rate allocations for the individual media.

# Superseded by a more recent version

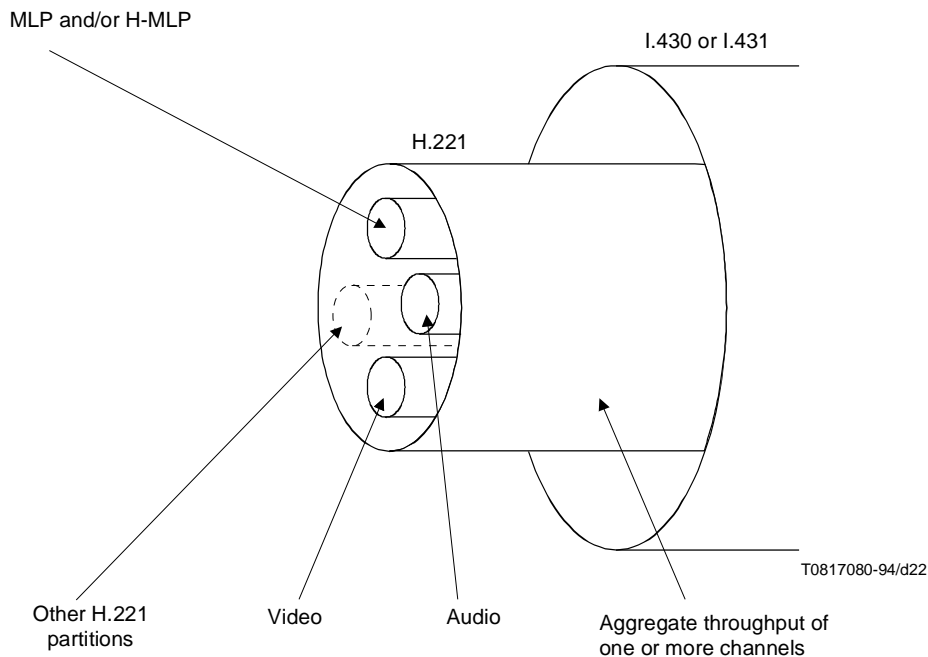

**Figure A.1/T.123 – Integration of multimedia signals framed according to Recommendation H.221**

## Appendix I

### Multimedia conference call set-up in the ISDN

#### I.1 Introduction

Multimedia Conference (MMC) terminals, currently under standardisation in ITU-T, are basically intended to operate within the ISDN. However, various terminals of different types such as telephone, facsimile Group 4, videophones, and teleconference systems are also connected to the ISDN.

The following scenarios are derived from Recommendation Q.931, which provides more information and describes other possibilities. Attention should be paid to the coding of information elements for BC, LLC, and HLC, because they are important for interworking.

Table I.1 suggests values that may be used in a SETUP message. The called side terminal should also accept other values of the information elements for BC, LLC, and HLC. Alternative settings include unrestricted digital information with tones and announcements (UDI-TA), rate adaption to 56 kbit/s for restricted networks, double BC/HLC, and absence of LLC. When HLC is used, call acceptance should be configured by the user to allow either telephony 7 kHz, videotelephony, or telephony 3.1 kHz.

# Superseded by a more recent version

Table I.1/T.123 – Parameter settings originated in SETUP message

Information element	BC	LLC	HLC
Information transfer capability	Unrestricted digital information	Unrestricted digital information	
Transfer mode	Circuit	Circuit	
Information transfer rate	64 kbit/s	64 kbit/s	
User information layer 1 protocol		H.221	
High layer characteristics identification			AC <sup>a)</sup>
a) AC Audiographic Teleconference. VC (Videoconferencing), VP (Videophone) and AV (Audiovisual) are acceptable in the case of the called side.			

## I.2 Basic requirements

The following conditions are basically required:

- 1) An MMC terminal has the ISDN I/F function inside it and directly connects to the ISDN at a S(T) point.
- 2) An MMC terminal desires to intercommunicate with the following terminals:
  - a) MMC terminal;
  - b) Videophone, Teleconference with H.221 frame structure supported.

Items a) and b) mentioned above will together be called AV (audiovisual) terminals in the following.

Intercommunication between MMC terminals and telephones are the fundamental demand. But each side uses different ISDN services (e.g. MMC: unrestricted digital information, telephone: speech), therefore this type of intercommunication would be difficult, without using special sequences, as shown in Figures I.2 and I.3.

- 3) This description is on the point-to-point connection only. The outline of the sequence is shown in Figure I.1.

## I.3 Connection phase

The connection procedure can be divided into the following three phases:

- 1) Phase A (ISDN D-channel protocol) – By using the D-channel signalling protocol (see Recommendation Q.931), an MMC terminal makes the call control so as to establish an ISDN B-channel, for communicating with an AV terminal.
- 2) Phase B (H.242 protocol) – An MMC terminal based on Recommendation H.221 establishes frame alignment and decides communication mode based on the H.242 sequence (MMC mode/speech mode), and establishes the MLP path.
- 3) Phase C (T.120-Series protocol) – In the case that both terminals have MMC functionality and decide to communicate by MMC mode, the T.120 protocol is started and the final communication function in detail is decided, leading to the start of actual communication.

# Superseded by a more recent version

## I.4 Phase A (ISDN D-channel protocol)

In making call control based on Recommendation Q.931 (D-channel signalling protocol), the parameters specified in Table I.1 are to be set in the SETUP message on the originating side. Here in this Recommendation, however, the table shows only about information elements of:

- 1) Bearer Capability (BC);
- 2) Low Layer Capability (LLC);
- 3) High Layer Capability (HLC),

all of which are needed to recognise the other terminals' communication capability.

An MMC terminal on the calling side should set the above parameters in the SETUP message for sending, whilst on the called side, it should check the parameters so as to judge the possibility of communication. Finding it possible to communicate, it may accept the call and connect to a B-channel. Then an MMC terminal starts to intercommunicate with an audiovisual terminal which may be another MMC terminal, or another type of audiovisual terminal such as videophone.

## I.5 Phase B (H.242 protocol)

After connecting to the B-channel, the following procedures should be carried out based on Recommendation H.242:

- 1) Frame alignment conforming to Recommendation H.221 is the mode. Then, by using BAS, the capability exchange sequence is executed in 7-bit PCM mode (Mode 0F).
- 2) After each side recognises the other's capability, they decide their own communication mode including common mode. That is, when both are sure of having MLP capability, the MLP path is established and the T.120 protocol is started, leading to phase C.
- 3) In the case where one side has no MLP capability, their communication is limited to audio and possibly video (for example, if one side is an MMC and the other side is a videophone).

## I.6 Phase C (T.120-Series protocol)

- 1) To establish a Data Link connection on the MLP path.
- 2) To establish layer 4.
- 3) After channels are established conforming with Recommendation T.125, the negotiations, in order to recognise each other's function regarding MMC and information necessary for the conference, are exchanged by Generic Conference Control through the application roster.

# Superseded by a more recent version

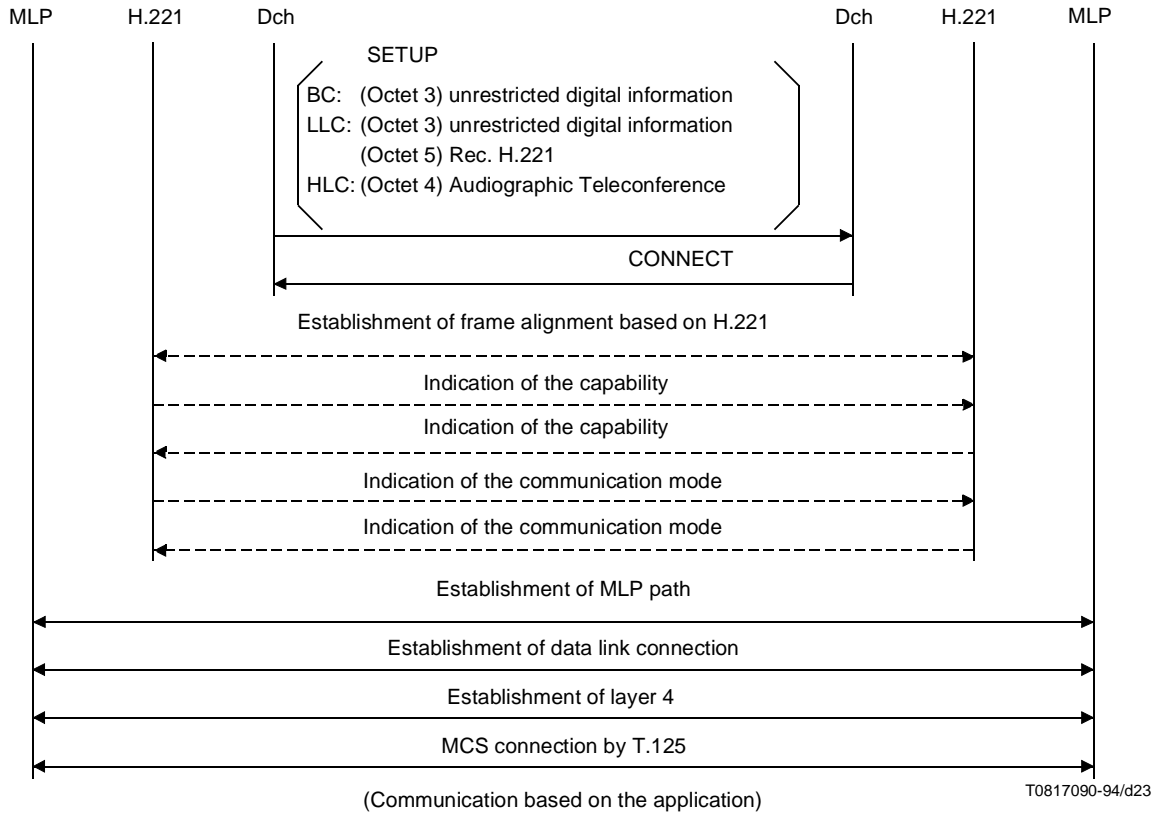
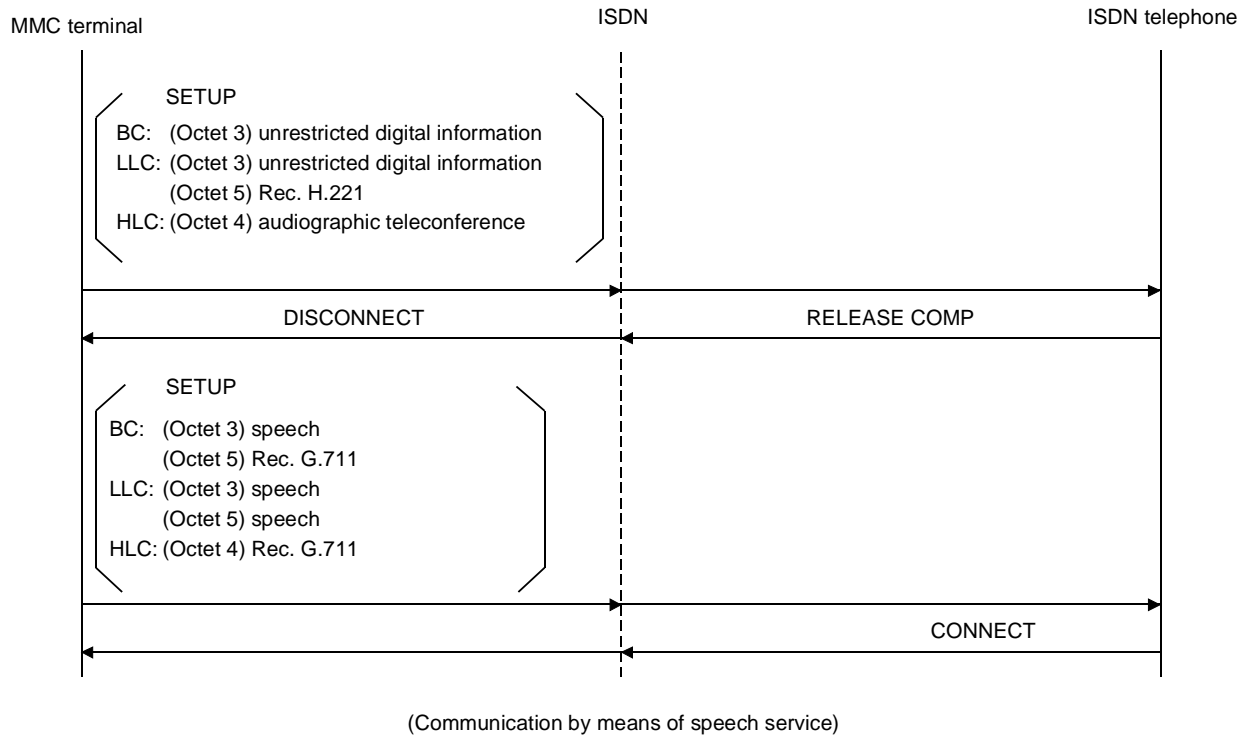

Figure I.1/T.123 – Communication establishment sequence for MMC terminals

# Superseded by a more recent version

## 1) Call from MMC terminal to ISDN telephone



## 2) Call from ISDN telephone to MMC terminal

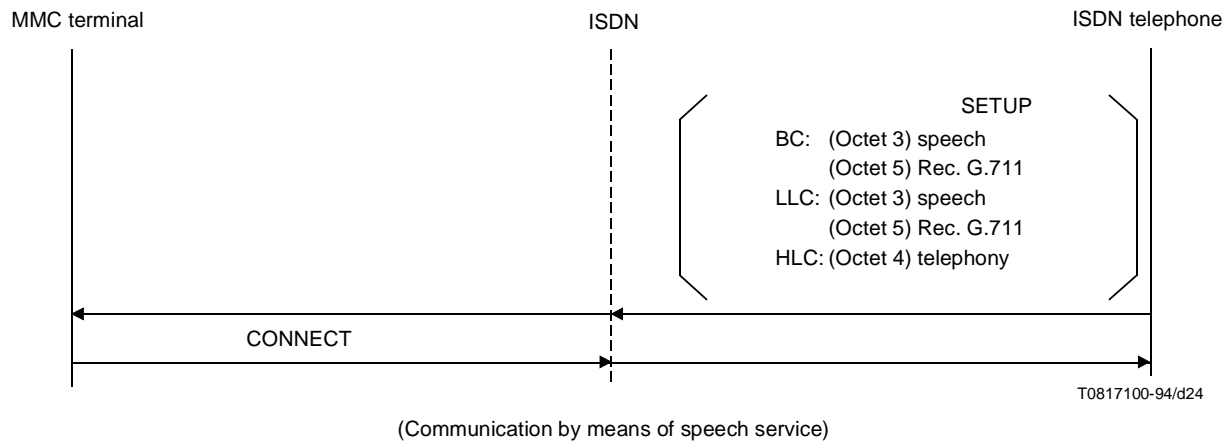
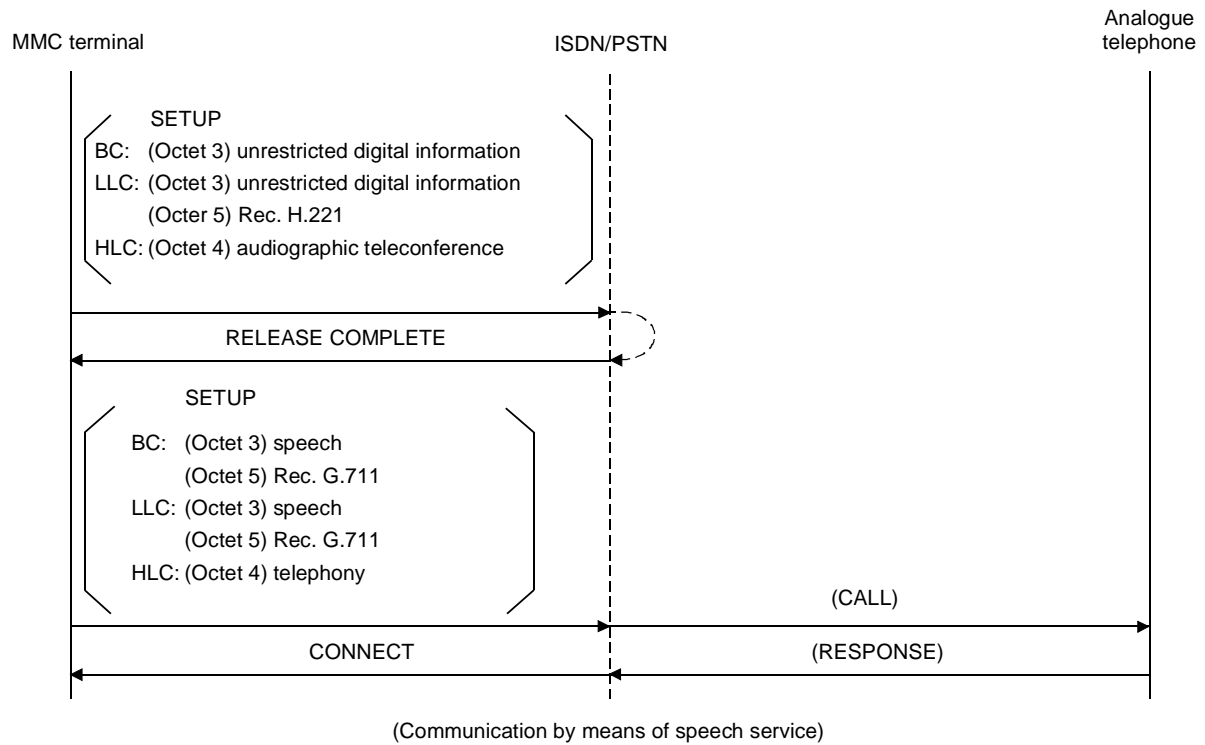

Figure I.2/T.123 – Intercommunication sequences for MMC terminal and ISDN telephone



# Superseded by a more recent version

## 3) Call from MMC terminal to analogue telephone



## 4) Call from analogue telephone to MMC terminal

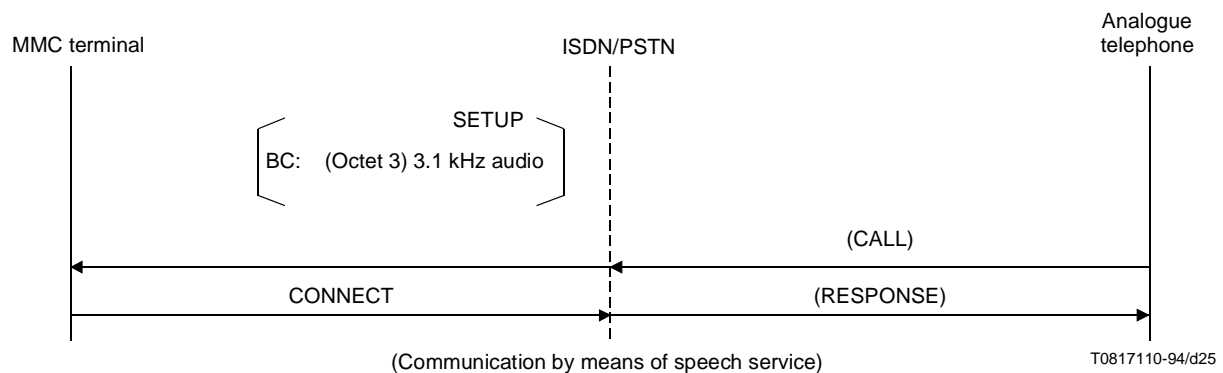

Figure I.3/T.123 – Intercommunication sequences for MMC terminal and analogue telephone



# Superseded by a more recent version

## ITU-T RECOMMENDATIONS SERIES

- Series A Organization of the work of the ITU-T
- Series B Means of expression: definitions, symbols, classification
- Series C General telecommunication statistics
- Series D General tariff principles
- Series E Overall network operation, telephone service, service operation and human factors
- Series F Non-telephone telecommunication services
- Series G Transmission systems and media, digital systems and networks
- Series H Audiovisual and multimedia systems
- Series I Integrated services digital network
- Series J Transmission of television, sound programme and other multimedia signals
- Series K Protection against interference
- Series L Construction, installation and protection of cables and other elements of outside plant
- Series M Maintenance: international transmission systems, telephone circuits, telegraphy, facsimile and leased circuits
- Series N Maintenance: international sound programme and television transmission circuits
- Series O Specifications of measuring equipment
- Series P Telephone transmission quality, telephone installations, local line networks
- Series Q Switching and signalling
- Series R Telegraph transmission
- Series S Telegraph services terminal equipment
- Series T Terminals for telematic services**
- Series U Telegraph switching
- Series V Data communication over the telephone network
- Series X Data networks and open system communication
- Series Z Programming languages