



INTERNATIONAL TELECOMMUNICATION UNION

CCITT

THE INTERNATIONAL
TELEGRAPH AND TELEPHONE
CONSULTATIVE COMMITTEE

V.32

(11/1988)

SERIES V: DATA COMMUNICATION OVER THE
TELEPHONE NETWORK

Interfaces and voice-band modems

**A FAMILY OF 2-WIRE, DUPLEX MODEMS
OPERATING AT DATA SIGNALLING RATES OF
UP TO 9600 bit/s FOR USE ON THE GENERAL
SWITCHED TELEPHONE NETWORK AND ON
LEASED TELEPHONE-TYPE CIRCUITS**

Reedition of CCITT Recommendation V.32 published in
the Blue Book, Fascicle VIII.1 (1988)

NOTES

- 1 CCITT Recommendation V.32 was published in Fascicle VIII.1 of the *Blue Book*. This file is an extract from the *Blue Book*. While the presentation and layout of the text might be slightly different from the *Blue Book* version, the contents of the file are identical to the *Blue Book* version and copyright conditions remain unchanged (see below).
- 2 In this Recommendation, the expression “Administration” is used for conciseness to indicate both a telecommunication administration and a recognized operating agency.

Recommendation V.32

A FAMILY OF 2-WIRE, DUPLEX MODEMS OPERATING AT DATA SIGNALLING RATES OF UP TO 9600 BIT/S FOR USE ON THE GENERAL SWITCHED TELEPHONE NETWORK AND ON LEASED TELEPHONE-TYPE CIRCUITS

(Malaga-Torremolinos, 1984, amended at Melbourne, 1988)

1 Introduction

This family of modems is intended for use on connections on general switched telephone networks (GSTNs) (see Note 1) and on point-to-point leased telephone-type circuits. The principal characteristics of the modems are as follows:

- a) Duplex mode of operation on GSTN and 2-wire point-to-point leased circuits (see Note 2).
- b) Channel separation by echo cancellation techniques.
- c) Quadrature amplitude modulation for each channel with synchronous line transmission at 2400 bauds.
- d) Any combination of the following data signalling rates may be implemented in the modems:
9600 bit/s synchronous,
4800 bit/s synchronous,
2400 bit/s synchronous (for further study).
- e) At 9600 bit/s, two alternative modulation schemes, one using 16 carrier states and one using trellis coding with 32 carrier states, are provided for in this Recommendation. However, modems providing the 9600 bit/s data signalling rate shall be capable of interworking using the 16-state alternative.
- f) Exchange of rate sequences during start-up to establish the data rate, coding and any other special facilities.
- g) Optional provision of an asynchronous mode of operation in accordance with Recommendation V.14.

Note 1 – On international GSTN connections that utilize circuits that are in accord with Recommendation G.235 (16-channel terminal equipments), it may be necessary to employ a greater degree of equalization within the modem than would be required for use on most national GSTN connections.

Note 2 – The transmit and receive rates in each modem shall be the same. The possibility of asymmetric working remains for further study.

2 Line signals

2.1 Carrier frequency

The carrier frequency is to be 1800 ± 1 Hz. No separate pilot tones are to be provided. The receiver must be able to operate with received frequency offsets of up to ± 7 Hz.

2.2 Transmitted spectrum

The transmitted power level must conform to Recommendation V.2. With continuous binary ones applied to the input of the scrambler, the transmitted energy density at 600 Hz and 3000 Hz should be attenuated 4.5 ± 2.5 dB with respect to the maximum energy density between 600 Hz and 3000 Hz.

2.3 Modulation rate

The modulation rate shall be 2400 bauds $\pm 0.01\%$.

2.4 Coding

2.4.1 Signal element coding for 9600 bit/s

Two alternatives are defined:

2.4.1.1 *Nonredundant coding*

The scrambled data stream to be transmitted is divided into groups of 4 consecutive data bits. The first two bits in time Q_{1_n} and Q_{2_n} in each group, where the subscript n designates the sequence number of the group, are differentially encoded into Y_{1_n} and Y_{2_n} according to Table 1/V.32. Bits Y_{1_n} , Y_{2_n} , Q_{3_n} and Q_{4_n} are then mapped into the coordinates of the signal state to be transmitted according to the signal space diagram shown in Figure 1/V.32 and as listed in Table 3/V.32.

2.4.1.2 *Trellis coding*

The scrambled data stream to be transmitted is divided into groups of 4 consecutive data bits. As shown in Figure 2/V.32, the first two bits in time Q_{1_n} and Q_{2_n} in each group, where the subscript n designates the sequence number of the group, are first differentially encoded into Y_{1_n} and Y_{2_n} according to Table 2/V.32. The two differentially encoded bits Y_{1_n} and Y_{2_n} are used as input to a systematic convolutional encoder which generates a redundant bit Y_{0_n} . This redundant bit and the 4 information-carrying bits Y_{1_n} , Y_{2_n} , Q_{3_n} and Q_{4_n} are then mapped into the coordinates of the signal element to be transmitted according to the signal space diagram shown in Figure 3/V.32 and as listed in Table 3/V.32.

2.4.2 *Signal element coding for 4800 bit/s*

The scrambled data stream to be transmitted is divided into groups of 2 consecutive data bits. These bits, denoted Q_{1_n} and Q_{2_n} , where Q_{1_n} is the first in time, and the subscript n designates the sequence number of the group, are differentially encoded into Y_{1_n} and Y_{2_n} according to Table 1/V.32. Figure 1/V.32 shows the subset A, B, C and D of signal states used for 4800 bit/s transmission.

2.4.3 *Signal element coding for 2400 bit/s*

(For further study.)

3 Interchange circuits

3.1 *List of interchange circuits*

These are listed in Table 4/V.32 below.

3.2 *Transmit data*

The modems shall accept synchronous data from the DTE on circuit 103 under control of circuit 113 or 114.

3.3 *Receive data*

The modems shall pass synchronous data to the DTE on circuit 104 under the control of circuit 115.

3.4 *Timing arrangements*

Clocks shall be included in the modems to provide the DTE with transmitter signal element timing on circuit 114 and receiver signal element timing on circuit 115. The transmitter timing may originate in the DTE and be transferred to the modem via circuit 113. In some applications it may be necessary to slave the transmitter timing to the receiver timing inside the modem.

3.5 *Data rate control*

Data rate selection may be by switch (or similar means) or alternatively by circuit 111. In cases where three different data signalling rates are implemented in a modem, a manual selector may be provided which determines the two data signalling rates selected by circuit 111.

The ON condition of circuit 111 selects the higher data signalling rate and the OFF condition of circuit 111 selects the lower data signalling rate.

3.6 *Circuit 106*

After the start-up and retrain sequences, circuit 106 must follow the state of circuit 105 within 2 ms.

TABLE 1/V.32

Differential quadrant coding for 4800 bit/s and for nonredundant coding at 9600 bit/s

Inputs		Previous outputs		Phase quadrant change	Outputs		Signal state for 4800 bit/s
Q1 _n	Q2 _n	Y1 _{n-1}	Y2 _{n-1}		Y1 _n	Y2 _n	
0	0	0	0	+ 90°	0	1	B
0	0	0	1		1	1	C
0	0	1	0		0	0	A
0	0	1	1		1	0	D
0	1	0	0	0°	0	0	A
0	1	0	1		0	1	B
0	1	1	0		1	0	D
0	1	1	1		1	1	C
1	0	0	0	+ 180°	1	1	C
1	0	0	1		1	0	D
1	0	1	0		0	1	B
1	0	1	1		0	0	A
1	1	0	0	+ 270°	1	0	D
1	1	0	1		0	0	A
1	1	1	0		1	1	C
1	1	1	1		0	1	B

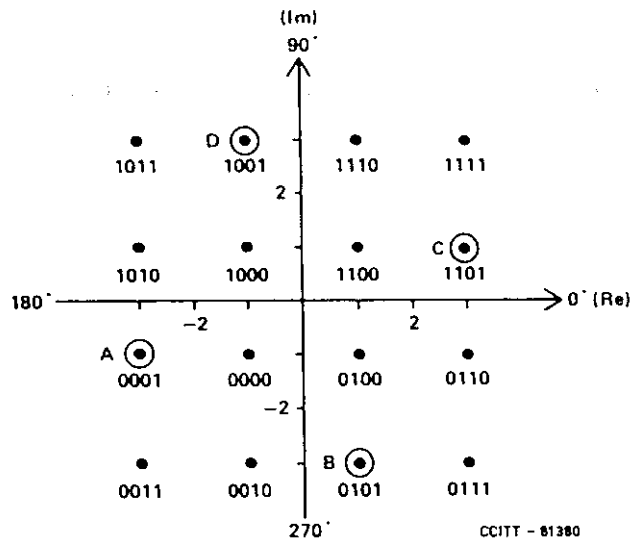

The binary numbers denote Y1_n Y2_n Q3_n Q4_n

FIGURE 1/V.32

16-point signal structure with nonredundant coding for 9600 bit/s and subset A B C D of states used at 4800 bit/s and for training

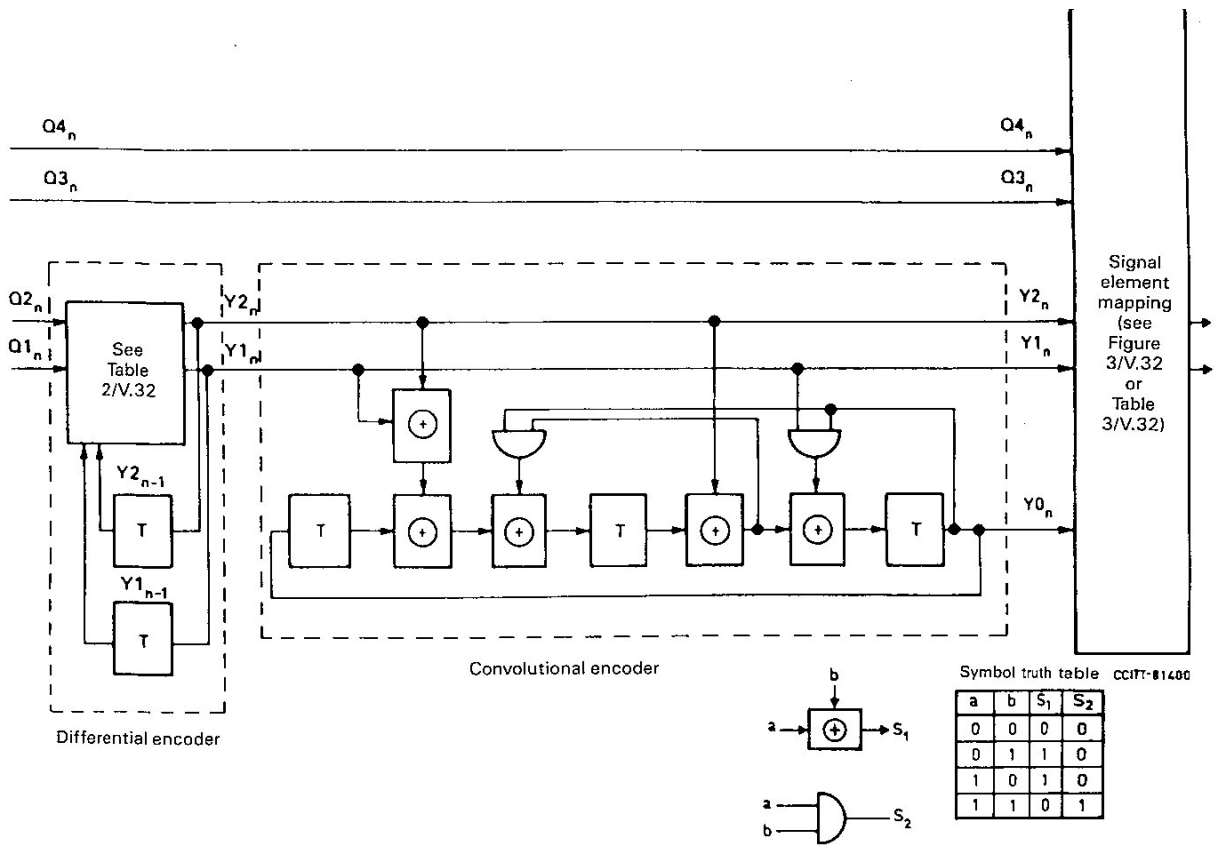

FIGURE 2/V.32

Trellis coding at 9600 bit/s

TABLE 2/V.32

Differential encoding for use with trellis coded alternative at 9600 bit/s

Inputs		Previous outputs		Outputs	
Q _{1n}	Q _{2n}	Y _{1n-1}	Y _{2n-1}	Y _{1n}	Y _{2n}
0	0	0	0	0	0
0	0	0	1	0	1
0	0	1	0	1	0
0	0	1	1	1	1
0	1	0	0	0	1
0	1	0	1	0	0
0	1	1	0	1	1
0	1	1	1	1	0
1	0	0	0	1	0
1	0	0	1	1	1
1	0	1	0	0	1
1	0	1	1	0	0
1	1	0	0	1	1
1	1	0	1	1	0
1	1	1	0	0	0
1	1	1	1	0	1

TABLE 3/V.32

The two alternative signal-state mappings for 9600 bit/s

Coded inputs (see Table 1/V.32 or Table 2/V.32 with Figure 2/V.32)					Nonredundant coding		Trellis coding	
(Y0)	Y1	Y2	Q3	Q4	Re	Im	Re	Im
0	0	0	0	0	-1	-1	-4	1
	0	0	0	1	-3	-1	0	-3
	0	0	1	0	-1	-3	0	1
	0	0	1	1	-3	-3	4	1
	0	1	0	0	1	-1	4	-1
	0	1	0	1	1	-3	0	3
	0	1	1	0	3	-1	0	-1
	0	1	1	1	3	-3	-4	-1
	1	0	0	0	-1	1	-2	3
	1	0	0	1	-1	3	-2	-1
	1	0	1	0	-3	1	2	3
	1	0	1	1	-3	3	2	-1
	1	1	0	0	1	1	2	-3
	1	1	0	1	3	1	2	1
	1	1	1	0	1	3	-2	-3
	1	1	1	1	3	3	-2	1
1	0	0	0	0			-3	-2
	0	0	0	1			1	-2
	0	0	1	0			-3	2
	0	0	1	1			1	2
	0	1	0	0			3	2
	0	1	0	1			-1	2
	0	1	1	0			3	-2
	0	1	1	1			-1	-2
	1	0	0	0			1	4
	1	0	0	1			-3	0
	1	0	1	0			1	0
	1	0	1	1			1	-4
	1	1	0	0			-1	-4
	1	1	0	1			3	0
	1	1	1	0			-1	0
	1	1	1	1			-1	4

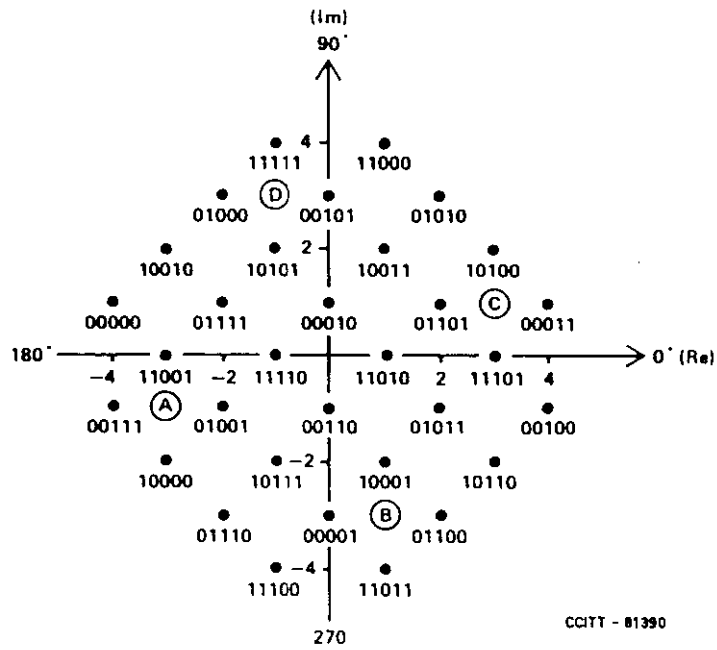

The binary numbers denote Y_0, Y_1, Y_2, Q_3, Q_4

FIGURE 3/V.32

32-point signal structure with trellis coding for 9600 bit/s and states A B C D used at 4800 bit/s and for training

TABLE 4/V.32

Interchange circuit (see Note 1)		Notes
No.	Description	
102	Signal ground or common return	
103	Transmitted data	
104	Received data	
105	Request to send	
106	Ready for sending	
107	Data set ready	
108/1 or	Connect data set to line	2
108/2	Data terminal ready	2
109	Data channel received line signal detector	
111	Data signalling rate selector (DTE source)	3
112	Data signalling rate selector (DCE source)	3
113	Transmitter signal element timing (DTE source)	5
114	Transmitter signal element timing (DCE source)	6
115	Receiver signal element timing (DCE source)	6
125	Calling indicator	4
140	Loopback/maintenance test	
141	Local loopback	
142	Test indicator	

Note 1 – All interchange circuits which are provided shall comply with the functional and operational requirements of Recommendation V.24. All interchange circuits shall be properly terminated in the data terminal equipment and in the data circuit-terminating equipment in accordance with the appropriate Recommendation for electrical characteristics (see § 3.8).

Note 2 – This circuit shall be capable of operation as circuit 108/1 or circuit 108/2 depending on its use. Operation of circuits 107 and 108/1 shall be in accordance with § 4.4 of Recommendation V.24.

Note 3 – This circuit is not essential when only one data signalling rate is implemented in the modem.

Note 4 – This circuit is for use with the general switched telephone network only.

Note 5 – When the modem is not operating in a synchronous mode at the interface, any signals on this circuit shall be disregarded. Many DTEs operating in an asynchronous mode do not have a generator connected to this circuit.

Note 6 – When the modem is not operating in a synchronous mode at the interface, this circuit shall be clamped to the OFF condition. Many DTEs operating in an asynchronous mode do not terminate this circuit.

3.7 *Circuit 109*

OFF to ON and ON to OFF transitions of circuit 109 should occur solely in accordance with the operating sequences defined in § 5. Thresholds and response times are inapplicable because a line signal detector cannot be expected to distinguish wanted received signals from unwanted talker echoes.

3.8 *Electrical characteristics of interchange circuits*

3.8.1 Use of electrical characteristics conforming to Recommendation V.28 is recommended together with the connector and pin assignment plan specified by ISO 2110.

Note – Manufacturers may wish to note that the long-term objective is to replace electrical characteristics specified in Recommendation V.28, and that Study Group XVII has agreed that the work shall proceed to develop a more efficient, all-balanced, interface for the V-Series application which minimizes the number of interchange circuits.

3.9 *Fault condition on interchange circuits*

See § 7 of Recommendation V.28 for association of the receiver failure detection types.

3.9.1 The DTE should interpret a fault condition on circuit 107 as an OFF condition using failure detection type 1.

3.9.2 The DCE should interpret a fault condition on circuits 105 and 108 as an OFF condition using failure detection type 1.

3.9.3 All other circuits not referred to above may use failure detection types 0 or 1.

4 **Scrambler and descrambler**

A self-synchronizing scrambler/descrambler shall be included in the modem. Each transmission direction uses a different scrambler. The method of allocating the scramblers/descramblers is described in § 4.1. According to the direction of transmission, the generating polynomial is:

Call mode modem generating polynomial: $(GPC) = 1 + x^{-18} + x^{-23}$, or

Answer mode modem generating polynomial: $(GPA) = 1 + x^{-5} + x^{-23}$

At the transmitter, the scrambler shall effectively divide the message data sequence by the generating polynomial. The coefficients of the quotients of this division, taken in descending order, form the data sequence which shall appear at the output of the scrambler. At the receiver the received data sequence shall be multiplied by the scrambler generating polynomial to recover the message sequence.

4.1 *Scrambler/descrambler allocation*

4.1.1 *General switched telephone network (GSTN)*

On the general switched telephone network, the modem at the calling data station (call mode) shall use the scrambler with the GPC generating polynomial and the descrambler with the GPA generating polynomial. The modem at the answering data station (answer mode) shall use the scrambler with the GPA generating polynomial and the

descrambler with the GPC generating polynomial. In some situations, however, such as when calls are established on the GSTN by operators, bilateral agreement on call mode/answer mode allocation will be necessary.

4.1.2 *Point-to-point leased circuits*

Scrambler/descrambler allocation and call mode and answer mode designation on point-to-point leased circuits will be by bilateral agreement between Administrations or users.

5 **Operating procedures**

5.1 *Recommendation V.25 automatic answering sequence*

The Recommendation V.25 automatic answering sequence shall be transmitted from the answer mode modem on international GSTN connections. The transmission of the sequence may be omitted on point-to-point leased circuits or on national connections on the GSTN where permitted by Administrations. In this event, the answer mode modem shall initiate transmission as in the retrain procedure specified in § 5.5.

5.2 *Receiver conditioning signal*

The receiver conditioning signal shall be used in the start-up and retrain procedures defined in §§ 5.4 and 5.5 below. The signal consists of three segments:

5.2.1 Segment 1, denoted by S in Figures 4/V.32 and 5/V.32, consists of alternations between states A and B as shown in Figure 1/V.32, for a duration of 256 symbol intervals.

5.2.2 Segment 2, denoted by \bar{S} in Figures 4/V.32 and 5/V.32, consists of alternations between states C and D as shown in Figure 1/V.32, for a duration of 16 symbol intervals.

The transition from segment 1 to segment 2 provides a well-defined event in the signal that may be used for generating a time reference in the receiver.

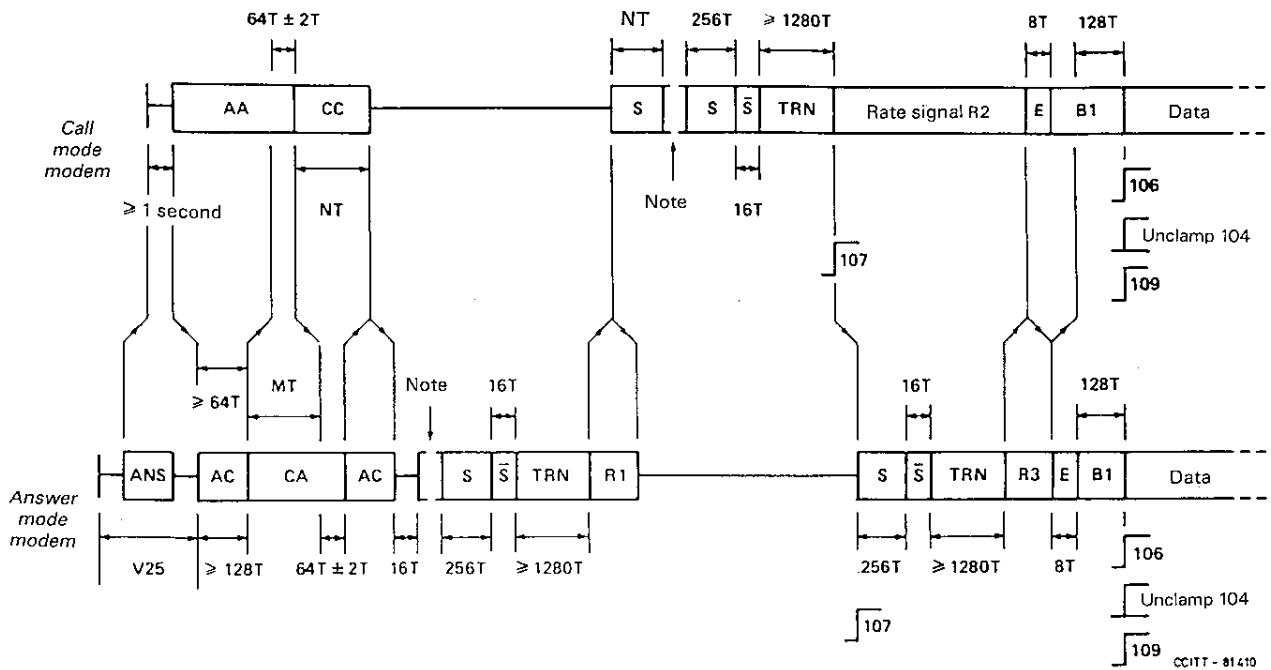

- AC Signal states ACAC..AC for an even number of symbol intervals T ; similarly with CA, AA and CC.
- MT, NT Round-trip delays observed from answer and call modems respectively, including $64T \pm 2T$ modem turn round delay.
- S, \bar{S} Signal states ABAB..AB, CDCD..CD.
- TRN Scrambled ones at 4800 bit/s with dibits encoded directly to states A, B, C and D as defined in § 5.2.3.
- R1, R2, R3 Each a repeated 16-bit rate sequence at 4800 bit/s scrambled and differentially encoded as in Table 1/V.32.
- E A single 16-bit sequence marking and following the end of a whole number of 16-bit rate sequences in R2 and R3.
- B1 Binary ones scrambled and encoded as for the subsequent transmission of data.

Note — The inclusion of a special echo canceller training sequence at this point is optional (see § 5.4, Note 3).

FIGURE 4/V.32

Start-up procedure

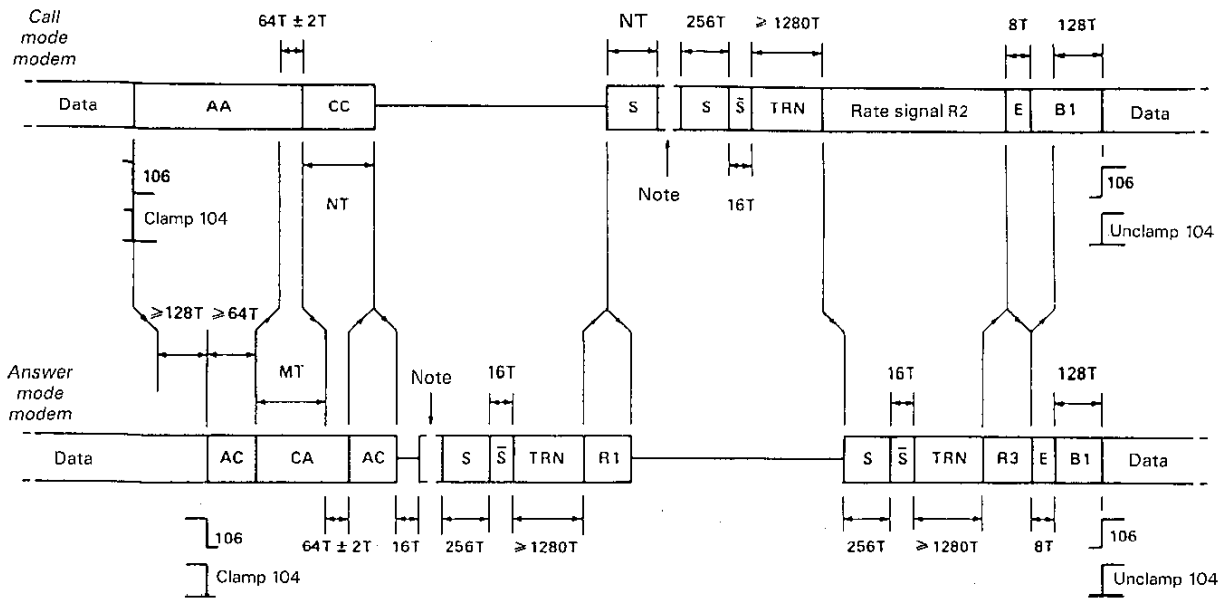

a) Retrain initiated by the calling modem

CCITT-81420

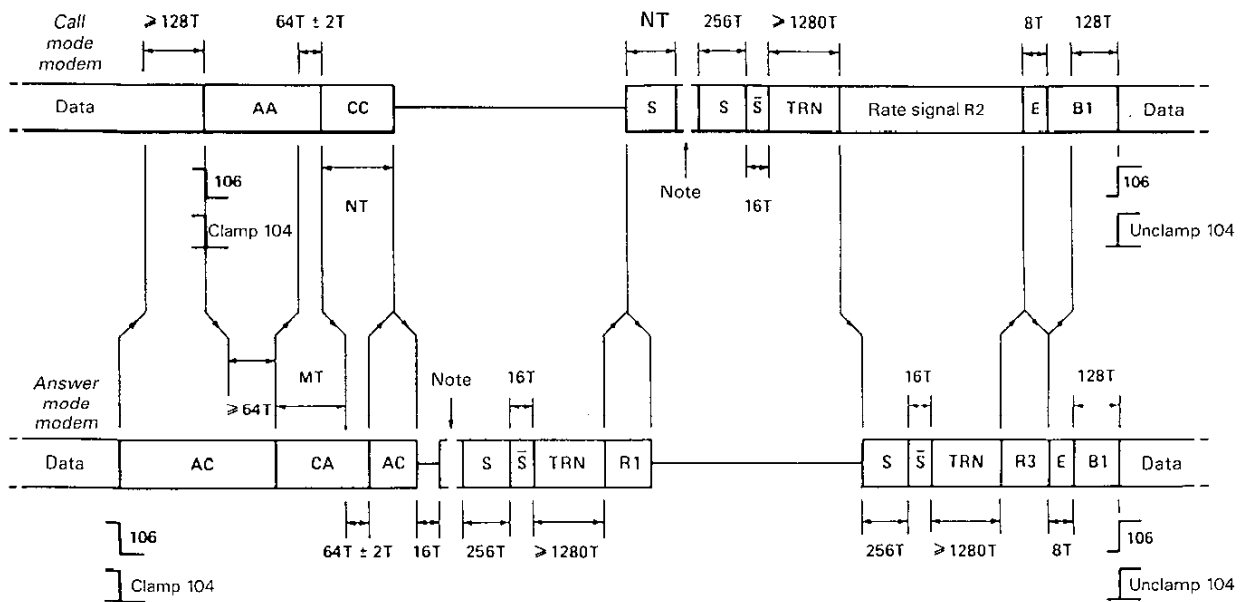

b) Retrain initiated by the answering modem

CCITT - 81430

- AC Signal states ACAC..AC for an even number of symbol intervals T; similarly with CA, AA and CC.
- MT, NT Round-trip delays observed from answer and call modems respectively, including $64T \pm 2T$ symbol intervals modem turn round delay.
- S, \bar{S} Signal states ABAB..AB, CDCD..CD.
- TRN Scrambled ones at 4800 bit/s with dibits encoded directly to states A, B, C and D as defined in § 5.2.3.
- R1, R2, R3 Each a repeated 16-bit rate sequence at 4800 bit/s scrambled and differentially encoded as in Table 1/V.32.
- E A single 16-bit sequence marking and following the end of a whole number of 16-bit rate sequences in R2 and R3.
- B1 Binary ones scrambled and encoded as for the subsequent transmission of data.

Note — The inclusion of a special echo canceller training sequence at this point is optional (see § 5.4, Note 3).

FIGURE 5/V.32

5.2.3 Segment 3, denoted by TRN in Figures 4/V.32 and 5/V.32, is a sequence derived by scrambling binary ones at a data rate of 4800 bit/s with the scrambler defined in § 4. During the transmission of this segment, the differential quadrant encoding shall be disabled. The initial state of the scrambler shall be all zeros, and a binary one applied to the input for the duration of segment 3. Successive dibits are encoded onto transmitted signal states.

The first 256 transmitted signal states are determined from the state of the first bit occurring (in time) in each dibit. When this bit is ZERO, signal state A is transmitted; when this bit is ONE, signal state C is transmitted. Depending on whether the modem is in call or answer mode, the scrambler output patterns and corresponding signal states will then begin as below, where the bits and the signal states are shown in time sequence from left to right.

Call mode modem:

GPC: 11 11 11 11 11 11 11 11 11 11 00 00 01 11 11 11
 CCCCCCCCCAAACCC

Answer mode modem:

GPA: 11 11 10 00 00 11 11 10 00 00 11 10 01 11 11
 CCCAACCCAACCACC

Immediately after 256 such symbols, successive scrambled dibits are encoded onto transmitted signal states in accordance with Table 5/V.32 directly without differential encoding for the remainder of segment 3. The duration of segment 3 shall be at least 1280 and not exceed 8192¹⁾ symbol intervals.

Segment 3 is intended for training the adaptive equaliser in the receiving modem and the echo canceller in the transmitting modem.

TABLE 5/V.32

Encoding for TRN segment after the first 256 symbols

Dibit	Signal state
00	A
01	B
11	C
10	D

Note – Signal states A, B, C and D are shown in Figure 1/V.32.

5.3 *Rate signal*

The rate signal consists of a whole number of repeated 16-bit binary sequences, as defined in Table 6/V.32, scrambled and transmitted at 4800 bit/s with dibits differentially encoded as in Table 1/V.32. The differential encoder shall be initialized using the final symbol of the transmitted TRN segment.

The first two bits and each successive dibit of the rate sequence shall be encoded to form the transmitted signal states.

The first transmitted octet, B0-B7, is fully defined in Table 6/V.32 and shall be interpreted by all Recommendation V.32 modems; the second octet, B8-B15, includes some codes defined in the table, some to be defined later and others to be left undefined for use by manufacturers.

¹⁾ The maximum duration of 8192 symbol intervals is for further study.

TABLE 6/V.32

Coding of the 16-bit rate sequence

B0	B1	B2	B3	B4	B5	B6	B7	B8	B9	10	11	12	13	14	15	B0	B1	B2	B3	B4	etc.
0	0	0	0	–	–	–	1	–	–	–	1	–	–	–	1	0	0	0	0	–	
B0-3, B7, 11, 15				For synchronizing on a received rate signal																	
B4				1 denotes ability to receive data at 2400 bit/s																	
B5				1 denotes ability to receive data at 4800 bit/s																	
B6				1 denotes ability to receive data at 9600 bit/s																	
B4-6				0 0 0 calls for a GSTN clear-down																	
B8				1 denotes availability of trellis coding/decoding at the highest data rate indicated in B4-6																	
B9-14				0 0 1 0 0 0 denotes absence of special operational modes																	

Note – The remaining codes may be allocated within Recommendation V.32 in the future.

5.3.1 *Detecting a rate signal*

The minimum requirement for detection is the receipt of two consecutive identical 16-bit sequences each with bits B0-3, B7, 11 and 15 conforming to Table 6/V.32.

5.3.2 *Ending the rate signal*

In order to mark the end of transmission of any rate signal other than R1 (Figure 4/V.32), the modem shall first complete the transmission of the current 16-bit rate sequence, and then transmit one 16-bit sequence E, coded as shown in Table 7/V.32.

TABLE 7/V.32

Coding of signal E

B0	B1	B2	B3	B4	B5	B6	B7	B8	B9	10	11	12	13	14	15
1	1	1	1	–	–	–	B1	–	–	–	1	–	–	–	1
B4-14		As in Table 6/V.32, except that the only data rate and coding to be indicated shall relate to the transmission of scrambled binary ones immediately following signal E													

5.4 *Start-up procedure*

The procedure for achieving synchronism between the calling modem and the answering modem on international GSTN connections is shown in Figure 4/V.32. The procedure includes the estimating of round-trip delay from each modem, the training of echo cancellers and receivers initially with half-duplex transmissions, and the exchanging of rate signals for automatic bit-rate and mode selection.

5.4.1 *Call mode modem*

After receiving the answer tone for a period of at least 1 s as specified in Recommendation V.25, the modem shall be connected to line (see Note 1 below) and shall condition the scrambler and descrambler in accordance with § 4.1.

The modem shall repetitively transmit carrier state A as shown in Figure 1/V.32.

The modem shall be conditioned to detect (see Note 2 below) one of two incoming tones at frequencies 600 ± 7 Hz and 3000 ± 7 Hz, and subsequently to detect a phase reversal in that tone.

On detection of one such phase reversal, the modem shall be conditioned to detect a second phase reversal in the same tone, start a counter/timer and change to repetitively transmitting state C as shown in Figure 1/V.32. The time delay between the reception of this phase reversal at the line terminals and the transmitted AA to CC transition appearing at the line terminals shall be 64 ± 2 symbol periods.

On detection of a second phase reversal in the same incoming tone, the modem shall stop the counter/timer and cease transmitting.

When the modem detects an incoming S sequence (see § 5.2), it shall proceed to train its receiver, and then seek to detect at least two consecutive identical 16-bit rate sequences as defined in Table 6/V.32.

On detection of the rate signal (R1), the modem shall transmit an S sequence for a period NT already estimated by the counter/timer.

After this period has expired (see Note 3 below), the modem shall transmit the receiver conditioning signal as defined in § 5.2, starting with an S sequence for 256 symbol intervals.

Transmission of the TRN segment of the receiver conditioning signal may be extended in order to ensure a satisfactory level of echo cancellation (see Note 4 below).

After the TRN segment, the modem shall apply an ON condition to circuit 107 and transmit a rate signal (R2) in accordance with § 5.3 to indicate the currently available data rates and whether trellis coding and/or other special operational modes are available. R2 shall exclude rates and operational modes not appearing in the previously received rate signal R1. It is recommended that R2 should also take account of the likely receiver performance with the particular GSTN connection. If it appears that satisfactory performance cannot be attained at any of the available data rates, then R2 should be used to call for a GSTN clear-down in accordance with Table 6/V.32.

Transmission of R2 shall continue until an incoming rate signal R3 is detected. The modem shall then, after completing its current 16-bit rate sequence, transmit a single 16-bit sequence E in accordance with § 5.3.2 indicating the data rate, coding and any special operational modes called for in R3. If, however, R3 is calling for a GSTN clear-down in accordance with Table 6/V.32, then the call modem shall disconnect from line and effect a clear-down.

The modem shall then transmit continuous scrambled binary ones at the data rate and with the coding called for in R3, and apply the appropriate condition to circuit 112. If trellis coding according to § 2.4.1.2 is to be used, the initial states of the delay elements of the convolution encoder shown in Figure 2/V.32 should be set to zero.

On detecting an incoming 16-bit E sequence as defined in § 5.3.2, the modem shall condition itself to receive data at the rate and with the coding indicated by the incoming E sequence. After a delay of 128 symbol intervals, it shall apply an ON condition to circuit 109, and unclamp circuit 104.

The modem shall then enable circuit 106 to respond to the condition of circuit 105 and be ready to transmit data.

5.4.2 *Answer mode modem*

On connection to line, the modem shall condition the scrambler and descrambler in accordance with § 4.1, and transmit the Recommendation V.25 answer sequence. Means, defined in Recommendation V.25, of disabling network echo cancellers and/or truncating the answer tone may be employed.

After the Recommendation V.25 answer sequence, the modem shall transmit alternate carrier states A and C as shown in Figure 1/V.32.

After alternate states A and C have been transmitted for an even number of symbol intervals greater than or equal to 128 *and* an incoming tone has been detected at 1800 ± 7 Hz for 64 symbol periods (see Note 5 below), the modem shall be conditioned to detect a phase reversal in the incoming tone, start a counter/timer, and change to transmitting alternate carrier states C and A for an even number of symbol intervals.

On detecting a phase reversal in the incoming tone, the modem shall stop the counter/timer and, after transmitting a state A, revert to transmitting alternate states A and C. The time delay between the reception of this phase reversal at the line terminals and the transmitted CA to AC transition appearing at the line terminals shall be 64 ± 2 symbol periods.

When an amplitude drop is detected in the incoming tone, the modem shall cease transmitting for a period of 16 symbol intervals and then (see Note 3) transmit the receiver conditioning signal as defined in § 5.2.

Transmission of the TRN segment of the receiver conditioning signal may be extended in order to ensure a satisfactory level of echo cancellation (see Note 4).

After the TRN segment, the modem shall transmit a rate signal (R1) in accordance with § 5.3 to indicate the data rates, coding and any special operational modes currently available in the answer modem and associated DTE.

On detection of an incoming S sequence, the modem shall cease transmitting.

The modem shall wait for a period MT already estimated by the counter/timer and then, if an incoming S sequence persists, or when an S sequence reappears (see Note 3), the modem shall proceed to train its receiver.

After training its receiver, the modem shall seek to detect at least two consecutive identical incoming 16-bit rate sequences as defined in § 5.3.

On detection of a rate signal (R2), the modem shall apply an ON condition to circuit 107 and transmit a second receiver conditioning signal as defined in § 5.2.

After the TRN segment, the modem shall transmit a second rate signal (R3) in order to indicate the data rate, coding and any special operational modes to be used by both modems. The data rate and operational modes selected by R3 shall be within those indicated by R2. It is recommended that R3 should also take account of the likely performance of the answer modem receiver with the particular GSTN connection established. If R2 is calling for a GSTN clear-down (see Table 6/V.32) and/or if it appears that satisfactory performance cannot be attained by the answer modem at any of the available data rates, then R3 should call for a GSTN clear-down, in accordance with Table 6/V.32.

When the modem detects an incoming 16-bit E sequence as defined in § 5.3.2, it shall condition itself to receive data at the rate and with the coding indicated by the E sequence.

The modem shall complete the current 16-bit rate sequence and then transmit a single 16-bit E sequence indicating the data rate and coding to be used in the subsequent transmission of scrambled binary ones. If trellis coding according to § 2.4.1.2 is to be used, then the initial states of the delay elements of the convolution encoder shown in Figure 3/V.32 should be set to zero.

The modem shall transmit scrambled binary ones for 128 symbol intervals, then enable circuit 106 to respond to the condition of circuit 105 and be ready to transmit data.

The modem shall also apply an ON condition to circuit 109 and unclamp circuit 104.

Note 1 – Once an incoming tone is detected at 600 ± 7 Hz or 3000 ± 7 Hz, the calling modem should proceed with the start-up sequence even if no 2100 Hz tone has been detected.

Note 2 – In some cases, the incoming tones may be preceded by a special pattern which may last up to 294 ms (see Appendix I).

Note 3 – The TRN segment in the receiver conditioning signal is suitable for training the echo canceller in the transmitting modem. Alternatively, it is acceptable to precede the receiver conditioning signal by a sequence which can be used specifically for training the echo canceller, but which need not be defined in detail in the Recommendation. The echo cancellation sequence (if used) must maintain energy transmitted to line to hold network echo control devices disabled (as required). In order to avoid confusion with Segments 1 or 2 of the receiver conditioning signal defined in § 5.2, the echo cancellation sequence shall produce a transmitted signal such that the sum of its power in the three 200 Hz bands centred at 600 Hz, 1800 Hz and 3000 Hz is at least 1 dB less than its power in the remaining bandwidth. This applies for the relative power averaged over any 6 ms time interval. The duration of this signal must not exceed 8192^2 symbol intervals.

Note 4 – Manufacturers are cautioned that a period of 650 ms is needed for training any network echo cancellers conforming to Recommendation G.165, that may be encountered on GSTN connections.

Note 5 – The answering modem may disconnect from the line if the 1800 ± 7 Hz tone is not detected following transmission of the segment AC. However, to assure compatibility with manual originating data stations, it shall not disconnect for at least 3 seconds after the segment AC has been transmitted.

5.5 *Retrain procedure*

A retrain may be initiated during data transmission if either modem incorporates a means of detecting unsatisfactory signal reception. Figure 5a/V.32 shows a retrain event initiated by the calling modem and Figure 5b/V.32 shows a retrain event initiated by the answering modem. The procedure is as follows:

5.5.1 *Call mode modem*

Following detection of unsatisfactory signal reception or detection of one of two tones at frequencies 600 ± 7 Hz and 3000 ± 7 Hz for more than 128 symbol intervals, the modem shall turn OFF circuit 106, clamp circuit 104 to binary one and repetitively transmit carrier state A as shown in Figure 1/V.32. It shall then proceed in accordance with § 5.4.1 beginning with the third paragraph (see Note in § 5.5.2).

5.5.2 *Answer mode modem*

Following detection of unsatisfactory signal reception or detection of a tone of frequency 1800 ± 7 Hz for more than 128 symbol intervals, the modem shall turn OFF circuit 106, clamp circuit 104 to binary one and transmit alternate carrier states A and C for an even number of symbol intervals not less than 128. It shall then proceed in accordance with § 5.4.2 beginning with the third paragraph (see Note).

Note – During a retrain, circuit 107 should remain ON.

²⁾ The maximum duration of 8192 symbol intervals is for further study.

(The need for a shorter duplex retrain procedure to provide for rapid training of the modem receivers is for further study.)

5.5.3 Operation of circuit 109 during retrain procedure

Circuit 109 shall be maintained in the ON condition except that the OFF condition may optionally be applied if transmission of the AA segment in the Call modem or of the first AC segment in the Answer modem continues for a period exceeding 45 seconds. If the retrain procedure is subsequently completed, the ON condition shall be re-applied to circuit 109 at the time that circuit 104 is unclamped.

6 Testing facilities

Test loops 2 and 3 as defined in Recommendation V.54 should be provided. Provision for test loop 2 shall be as specified for point-to-point circuits.

7 Asynchronous to synchronous conversion protocol – Modes of operation

The modem can be configured for the following modes of operation (modes 2 and 4 are optional):

- Mode 1 9600 bit/s \pm 0.01% synchronous
- Mode 2 9600 bit/s start-stop 8, 9, 10 or 11 bits per character
- Mode 3 4800 bit/s \pm 0.01% synchronous
- Mode 4 4800 bit/s start-stop 8, 9, 10 or 11 bits per character

7.1 Transmitter

7.1.1 In the synchronous modes of operation, the modem shall accept synchronous data from the DTE on circuit 103 under control of circuit 113 or circuit 114. The data shall then be scrambled in accordance with § 4 and then passed to the modulator for encoding in accordance with § 2.4.

7.1.2 In the start-stop modes, the modem shall accept a data stream of start-stop characters from the DTE at a nominal rate of 9600 or 4800 bit/s per second. The start-stop data to be transmitted shall be converted in conformity with Recommendation V.14 to a synchronous data stream suitable for transmission in accordance with § 7.1.1.

7.2 Receiver

Demodulated data shall be decoded in accordance with § 2.4, then descrambled in accordance with § 4 and then passed to the converter in conformity with Recommendation V.14 for regaining the data stream of start-stop characters.

The intracharacter signalling rate provided to the DTE over circuit 104 shall be in the ranges given in Table 8/V.32 when operating in the basic, or in the extended signalling rate ranges, respectively.

TABLE 8/V.32

Intracharacter signalling rate range

Data rate	Signalling rate range	
	Basic	Extended
9600 bit/s	9600 to 9696 bit/s	9600 to 9821 bit/s
4800 bit/s	4800 to 4848 bit/s	4800 to 4910 bit/s

APPENDIX I

(to Recommendation V.32)

Interworking procedure for echo cancelling modems

Considering

- that the V.26 *ter* modem at 2400 bit/s and the V.32 modems at 9600 bit/s and 4800 bit/s are based on the same technique, referred to as echo cancellation;
- that the 1800 Hz carrier frequency is the same for the two modems;
- that there may be a need for a modem, referred to as multimode, able to interwork with V.26 *ter* and V.32 modems;
- that the determination of round-trip delay may be useful in some cases,

the handshaking operating sequence defined in the following paragraphs is provided for the information of manufacturers.

I.1 *Interworking of echo cancelling modems*

The V.32 modems at 9600 bit/s and 4800 bit/s and the V.26 *ter* modems at 2400 bit/s could interwork with a dedicated multimode modem implementing both V.32 and V.26 *ter* capabilities, as illustrated in Table I-1/V.32.

Table I-1/V.32

Handshaking compatibility

Answering \ Calling	V.26 <i>ter</i>	V.32	M (Multimode)
V.26 <i>ter</i>	SYN 1200	No energy → F1 Disconnect	SYN 1200 then F1 (Note)
V.32	SYN 1200 disconnect → F2 Wait at least T1 = 300 ms	F1	SYN 1200 then F1 (Note)
M (Multimode)	SYN 1200	Detected transmit F2 → F1	F2 or SYN 1200 then F1 (Note)

Answer multimode modem

SYN 1200	RP	F1
----------	----	----

CCITT - 85 680

F1 : tones at 600 ± 7 Hz and 3000 ± 7 Hz generated by alternately transmitting carrier states A and C.

F2: tone at 1800 ± 7 Hz generated by repetitively transmitting carrier state A.

Note — The modem M is distinguished by a special rate pattern.

I.1.1 *Operation of the calling multimode modem*

The modem will recognize:

- A V.26 *ter* modem by detecting the 1200 baud synchronization signals followed by a rate pattern and then will proceed as defined in V.26 *ter* (see Figure I-1/V.32).
- V.32 modems by the detection of one of two incoming tones at frequencies 600 ± 7 Hz and 3000 ± 7 Hz (see Figure I-2/V.32). It will then proceed as defined in § 5.4.1.
- A multimode modem by the detection of a special rate pattern assigned to the multimode modem. It will transmit, as shown in Figure I-3/V.32, repetitively carrier state A or the synchronizing signals followed by the rate pattern, according to the selected mode of operation: V.32 or V.26 *ter* respectively.

I.1.2 Operation of the answering multimode modem

After the V.25 sequence, the modem will transmit the 1200 baud synchronizing signals followed by its special rate pattern, and then alternate carrier states A and C as defined in Recommendation V.32.

It will recognize during the transmission of these alternate carrier states A and C:

- a V.26 *ter* modem by the detection of the 1200 baud synchronizing signals followed by a rate pattern. It will stop transmitting alternate carrier states A and C and proceed according to Recommendation V.26 *ter* (see Figure I-4/V.32);
- V.32 modems by recognizing a tone at 1800 ± 7 Hz and will then proceed as defined in Recommendation V.32 (see Figure I-5/V.32).

The case of multimode modems on both answering and calling sides has been considered in § I.1.1.

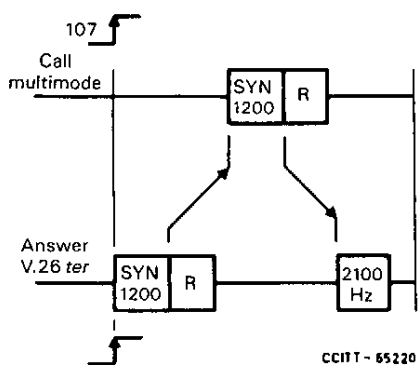

FIGURE I-1/V.32

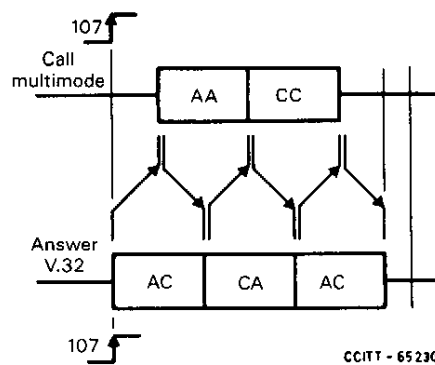

FIGURE I-2/V.32

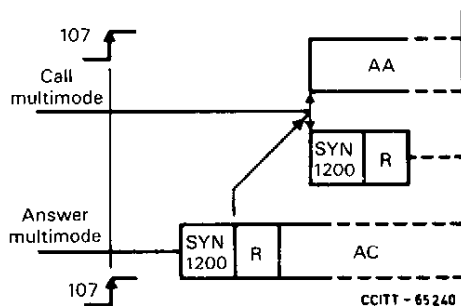

FIGURE I-3/V.32

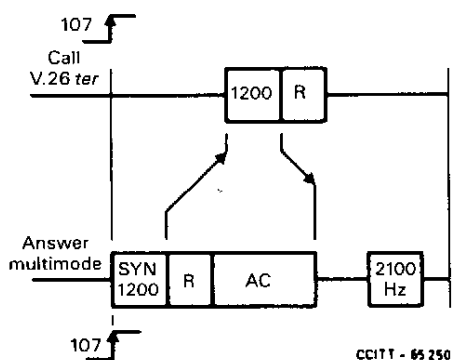

FIGURE I-4/V.32

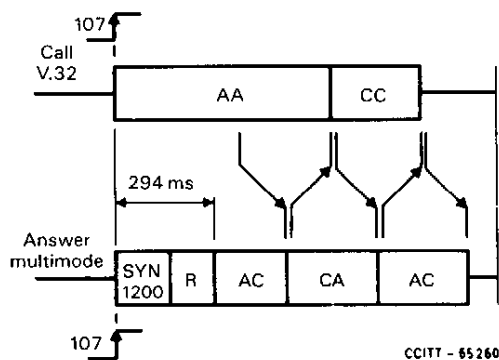

FIGURE I-5/V.32

ITU-T RECOMMENDATIONS SERIES

Series A	Organization of the work of the ITU-T
Series B	Means of expression: definitions, symbols, classification
Series C	General telecommunication statistics
Series D	General tariff principles
Series E	Overall network operation, telephone service, service operation and human factors
Series F	Non-telephone telecommunication services
Series G	Transmission systems and media, digital systems and networks
Series H	Audiovisual and multimedia systems
Series I	Integrated services digital network
Series J	Transmission of television, sound programme and other multimedia signals
Series K	Protection against interference
Series L	Construction, installation and protection of cables and other elements of outside plant
Series M	TMN and network maintenance: international transmission systems, telephone circuits, telegraphy, facsimile and leased circuits
Series N	Maintenance: international sound programme and television transmission circuits
Series O	Specifications of measuring equipment
Series P	Telephone transmission quality, telephone installations, local line networks
Series Q	Switching and signalling
Series R	Telegraph transmission
Series S	Telegraph services terminal equipment
Series T	Terminals for telematic services
Series U	Telegraph switching
Series V	Data communication over the telephone network
Series X	Data networks and open system communications
Series Y	Global information infrastructure and Internet protocol aspects
Series Z	Languages and general software aspects for telecommunication systems